

Collaborative Sleep Mechanism between Cross-domain Nodes in FiWi Network Based on Load Balancing and QoS Awareness

Xujing Peng

State Key Laboratory of Networking
and Switching Technology
Beijing University of Posts and
Telecommunications,
Beijing, 100086, China
Beijing, China
1209639378@qq.com

Xuesong Qiu

State Key Laboratory of Networking
and Switching Technology
Beijing University of Posts and
Telecommunications,
Beijing, 100086, China
Beijing, China
xsqiu@bupt.edu.cn

Siya Xu

State Key Laboratory of Networking
and Switching Technology
Beijing University of Posts and
Telecommunications,
Beijing, 100086, China
Beijing, China
xusiyaxsy@hotmail.com

Shuyang Li

State Grid Liaoning Electric
Power Co., Ltd.
Shenyang, 110006 China
Liaoning, China
lsy@ln.sgcc.com.cn

Shaoyong Guo

State Key Laboratory of Networking
and Switching Technology
Beijing University of Posts and
Telecommunications,
Beijing, 100086, China
Beijing, China
syguo@bupt.edu.cn

Botao Yu

Beijing Guodiantong Network
Technical Co. Ltd.,
Beijing, 100070 China
Beijing, China
yubotao@sgitg.sgcc.com.cn

Abstract—Fiber-Wireless Broadband Access Network (FiWi) not only has the advantages of high bandwidth and low data loss in optical network, but also has the characteristics of mobility and flexibility in wireless network. However, a large number of active devices in the FiWi network cause high energy consumption. Aiming at saving energy of FiWi network, this paper studies the collaborative sleep mechanism between cross-domain nodes in FiWi network based on load balancing and QoS awareness. Firstly, the energy consumption model of FiWi network is established to describe the device startup/shutdown energy consumption and service forwarding energy consumption. Secondly, a service route planning method for FiWi network based on load balancing and priority is proposed. The method is implemented by dividing network regions and allocating end-to-end routes for services within the region. Finally, a collaborative region sleep mechanism between ONU and wireless nodes is proposed. At the same time, the routes are redistributed for the affected services according to the service priority to ensure the accelerated forwarding of high-priority services. The simulation results show that the proposed mechanism can reduce the energy consumption, ensure the load balancing of the network, and improve the transmission rate of high-priority services.

Keywords—FiWi network, energy saving, collaborative sleep, load balancing, QoS awareness

I. INTRODUCTION

Fiber-Wireless (FiWi) Broadband Access Network combines the large capacity of fiber access and the mobility of wireless access, making it one of the most promising technologies in next-generation broadband access networks [1]. The FiWi network architecture is shown in Fig. 1. It usually adopts a "Tree-Mesh" topology, which consists of a tree topology PON network at the back end and a Wireless Mesh Network (WMN) at the front end. The main components in FiWi network are Optical Line Terminal (OLT), ONU-Mesh Portal Points (ONU-MPP), and wireless Mesh Access Point (MAP) [2]. OLT is in the central office of the PON network, which connects to ONU-MPPs through multiple distribution optical fibers. As an interface between the back-end PON network and the front-end WMN, ONU-

MPP (In the following text, we call it ONU) integrates the functions of ONU and the wireless gateway. It transmits data with the MAP through wireless links in WMN. As the end of FiWi access network, MAP is connected to multiple Subscriber Stations (STA) through air interfaces [3-4]. Global issues such as the greenhouse effect and energy crisis are major factors that constrain social development, while the energy consumption of the access network accounts for about 70% of the energy consumption in the entire communication network [5]. Although the FiWi network is more energy efficient than the optical network because it uses fewer high-power optical devices while supplementing with low-power wireless routers, the existing network is not load balanced and is usually idle, which still causes a huge waste of energy. For the purpose of green operation of the FiWi network, suitable device sleep mechanisms can save energy while not affecting communication quality [6].

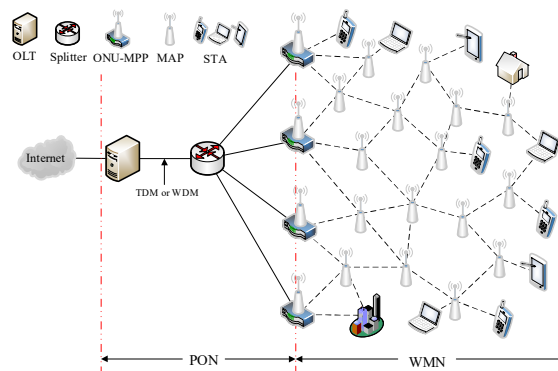

Fig. 1. FiWi network architecture

This paper will solve the energy-saving problem by collaborative sleep mechanism in FiWi Network. The rest of this paper is organized as follows. Section II introduces the related work on energy-saving of FiWi network. Section III introduces the FiWi network energy consumption and revenue model. Section IV describes the FiWi network collaborative sleep mechanism in detail. Section V introduces the simulation and evaluation of the mechanism. Section VI concludes the paper.

II. RELATED WORK

At present, energy-saving research in FiWi network is mainly concentrated on the sleep mechanism of ONU [7-8]. In the ONU sleep mode, depending on whether the ONU has data to be transmitted, it periodically switches to the active or sleep state[9]. In order to achieve the energy saving of the FiWi network by sending the ONUs to sleep and guaranteeing the quality of service (QoS), some scholars have conducted related research.

Reference [10] proposed a load transfer mechanism between the dormant ONU and the active ONU to decrease the transmission delay caused by ONU sleep. That is, the load of the dormant ONU is rerouted to the active ONU through the front-end multi-hop mesh network for forwarding. Reference [11] proposed a dynamic energy-saving mechanism, including load sensing, active/sleep transition and traffic rerouting. The mechanism selected the ONU with the highest load as the destination node to increase the number of dormant ONUs, and transferred the traffic in the low-load ONU to the high-load ONU. However, this mechanism would cause the network load to be unbalanced. Reference [12] dynamically scheduled the power state of the ONU by comparing its load with the threshold, and then configured the topology of the wireless subnet to achieve energy saving. Reference [13] proposed a packet aggregation energy-saving strategy, which aggregated data packets first and then sent them to extend ONU sleep time. But this mechanism will introduce a large transmission delay to the services. Reference [14] proposed a correlation-aware energy-saving mechanism. According to the reachability and traffic distribution of the wireless nodes to the ONU, the optimal ONU enters into the long-sleep state. However, this algorithm did not take energy savings for wireless nodes and QoS guarantees for services into consideration.

In summary, the problems of the above mechanisms are as follows: (a) These mechanisms mainly focused on the ONU sleep, but have not paid attention to the energy saving of the wireless nodes. The sleep of the ONU makes the nearby wireless nodes idle, so it is necessary to reduce energy waste by sending these wireless nodes to sleep [15]. (b) In order to make more ONUs sleep, most energy-saving mechanisms would cause unbalanced load distribution. (c) The above mechanisms did not distinguish the QoS requirements of different services, failing in meeting the differentiated service requirements of the distribution of communication services [16].

Aiming at solving the above problems and realizing the energy-saving goal of FiWi network, this paper proposes a collaborative sleep mechanism between cross-domain nodes in FiWi network based on load balancing and QoS awareness. The main contributions are as follows:

- Firstly, the FiWi network energy consumption model is established to describe the device startup/shutdown energy consumption and service forwarding energy consumption. On this basis, the network service revenue model is established.
- Secondly, a route planning method for FiWi network service based on load balancing and priority is proposed. The method is implemented by dividing multiple ONU-centric network regions and

allocating end-to-end routes for multi-level services within the region.

- Finally, a collaborative region sleep mechanism between ONU and wireless nodes based on load transfer is proposed. At the same time, the routes are redistributed for the affected services according to the service priority to ensure the accelerated forwarding of high-priority services.

III. SYSTEM MODEL

A. FiWi network model

A FiWi network can be represented as a weighted undirected graph $G^S = (N^S, L^S)$, where N^S is the node set of the network and N is the total number of network nodes. Each node $n_i^S \in N^S, i \in \{1, \dots, N\}$ has CPU computing power $C(n_i^S)$ and geographic location $Loc(n_i^S) = (x_i, y_i)$. L^S is the link set of the network, and $l_{mn}^S \in L^S (m, n = 1, \dots, N)$ is a path connecting the nodes n_m^S and n_n^S . The path can be composed of multiple links connected in series [17]. When performing service routing, the FiWi network has the following two constraints:

1) CPU computing power limit

CPU computing power limit indicates that when performing service routing, the remaining CPU computing power of each node in the transmission path should be greater than the computing requirement of the service, which can be expressed as (1).

$$SR_{cpu} \leq C_{mi}(n_i^S) - C_{use}(n_i^S) \quad (1)$$

Where, SR_{cpu} denotes the CPU computing requirement of the service request, $C_{mi}(n_i^S)$ and $C_{use}(n_i^S)$ indicate the initial and the used CPU computing power of node n_i^S , respectively.

2) Link bandwidth constraint

Link bandwidth constraint indicates that in service routing, each link bandwidth of all links in the transmission path should be greater than the service required bandwidth, which can be defined as (2).

$$SR_{band} \leq B_{mi}(l_{mn}^S) - B_{use}(l_{mn}^S) \quad (2)$$

Where, SR_{band} represents the bandwidth requirement of service request, $B_{mi}(l_{mn}^S)$ and $B_{use}(l_{mn}^S)$ indicate the initial bandwidth and the used bandwidth of link l_{mn}^S , respectively.

B. FiWi network energy consumption

The energy consumption of a FiWi network consists of two parts. One part is the device startup/shutdown energy consumption of the ONUs and the wireless nodes MAPs. The other part is the service forwarding energy consumption. In order to uniformly calculate the two parts, combined with the characteristics of the FiWi network, we set the calculation period of the energy consumption as a polling cycle T_{cy} of the OLT.

1) Equipment startup/shutdown energy consumption

The energy consumption of the FiWi device needs to be calculated separately for the ONU and the wireless node MAP in the time of T_{cy} .

In terms of ONU, assuming that the total number in the FiWi network is N and the number of active states is n . The ONU energy consumption in T_{cy} can be expressed as (3).

$$E_{ONU} = \sum_{l=1}^n E_{ac} + \sum_{k=1}^{N-n} E_{sl} = \sum_{l=1}^n P_{ac} \times T_{cy} + \sum_{k=1}^{N-n} P_{sl} \times T_{cy} \quad (3)$$

Where, E_{ac} and E_{sl} indicate the ONU energy consumption in the active and sleep state, respectively. Correspondingly, P_{ac} and P_{sl} denote their powers, respectively.

In terms of MAP, it is assumed that the total number in the network is N^w . The number of MAPs that are sleeping due to the sleep of the ONUs are $N_1, N_2, \dots, N_{N-1}, N_N$, respectively. So that the MAP energy consumption in the time of T_{cy} can be described as (4).

$$E_{MAP} = E_{ac}^w + E_{sl}^w = \left(N^w - \sum_{k=1}^N N_k \right) \times T_{cy} \times P_{ac}^w + \sum_{k=1}^N N_k \times T_{cy} \times P_{sl}^w \quad (4)$$

Where, E_{ac}^w and E_{sl}^w indicate the MAP energy consumption in the active and sleep state, respectively. P_{ac}^w and P_{sl}^w represent their powers, respectively.

2) Service Forwarding Energy Consumption

In the FiWi network, the service forwarding energy consumption is mainly concentrated in the wireless multi-hop part. Therefore, we only considers wireless forwarding energy consumption and adopts the typical wireless transmission energy consumption model in [18].

Assuming that during the time of T_{cy} , the number of services transmitted by the network is M . The bandwidth of each service is $B(SR_x), x \in \{1, 2, \dots, M\}$, and the distance forwarded of the service is $d(SR_x)$. Then the forwarding energy consumption in T_{cy} can be expressed as (5)-(7).

$$E_{trans} = \sum_{x=1}^M B(SR_x) (E_{send} + E_{receive} + \varepsilon_{fs} \times d(SR_x)^{index}) \quad (5)$$

$$index = \begin{cases} 2, & d(SR_x) < d_0 \\ 4, & d(SR_x) > d_0 \end{cases} \quad (6)$$

$$d_0 = \sqrt{\varepsilon_{fs} / \varepsilon_{mp}} \quad (7)$$

Where, E_{send} and $E_{receive}$ denote the energy consumed to send and receive a data packet by the electric circuit, respectively. ε_{fs} and ε_{mp} indicate the free space and multipath fading signal amplification coefficients, respectively. The result d_0 calculated by (7) is a constant.

In summary, during a polling cycle T_{cy} of the OLT, the FiWi network energy consumption can be described as (8).

$$E_{energy} = E_{ONU} + E_{MAP} + E_{trans} \\ = \left(\sum_{l=1}^n P_{ac} + \sum_{k=1}^{N-n} P_{sl} \right) \times T_{cy} + \left\{ \left(N^w - \sum_{k=1}^N N_k \right) \times P_{ac}^w + \sum_{k=1}^N N_k \times P_{sl}^w \right\} \times T_{cy} \\ + \sum_{x=1}^M B(SR_x) \times (E_{send} + E_{receive} + \varepsilon_{fs} \times d(SR_x)^{index}) \quad (8)$$

C. FiWi network revenue

In the FiWi network environment, the clients make service requests to the network service provider (NSP), and once the network completes the services transmission, it brings revenue to the NSP. In general, the revenue of accepting a service request are related to the CPU, bandwidth resource requirements, and duration of the service. In a polling cycle T_{cy} of the OLT, the revenue of accepting M service requests to the NSP are expressed as (9).

$$R_{revenue}(SR) = \sum_{x=1}^M T(SR_x) \times \left(P_{cpu} \times \sum_{n_i^s \in N^s} C_x(n_i^s) + p_B \times \sum_{l_{ij}^s(n_i^s, n_j^s) \in L^s} B_x(l_{ij}^s) \right) \quad (9)$$

Where, $T(SR_x)$ denotes the duration of the service request SR_x , $\sum_{n_i^s \in N^s} C_x(n_i^s)$ and $\sum_{l_{ij}^s(n_i^s, n_j^s) \in L^s} B_x(l_{ij}^s)$ represent the CPU computing power and the bandwidth requirements of the SR_x , respectively. p_{cpu} and p_B indicate the parameters for adjusting the CPU computing power and bandwidth weight.

The NSP obtains revenue by providing services, while taking on resource consumption at the same time. To this end, the objective function is to maximize the profit of the network service provider, which can be described as (10).

$$P_{profit} = R_{revenue}(SR) - E_{energy} \\ = \sum_{x=1}^M T(SR_x) \times \left(p_{cpu} \times \sum_{n_i^s \in N^s} C_x(n_i^s) + p_B \times \sum_{l_{ij}^s(n_i^s, n_j^s) \in L^s} B_x(l_{ij}^s) \right) \\ - \left(\sum_{l=1}^n P_{ac} + \sum_{k=1}^{N-n} P_{sl} \right) \times T_{cy} - \left\{ \left(N^w - \sum_{k=1}^N N_k \right) \times P_{ac}^w + \sum_{k=1}^N N_k \times P_{sl}^w \right\} \times T_{cy} \\ - \sum_{x=1}^M B(SR_x) (E_{send} + E_{receive} + \varepsilon_{fs} \times d(SR_x)^{index}) \quad (10)$$

IV. ALGORITHM DESCRIPTION

This section will introduce the complete sleep mechanism for the FiWi network in detail, which mainly includes two processes. One is the initial route planning strategy of the service, including network region division and performing end-to-end routing in the region. The other is the region dormancy strategy based on load transfer, including letting the network region perform sleep/active transitions according to the load and rerouting the affected services.

A. Service route planning mechanism based on load balancing and priority

After the wireless terminal STA generates a service request, the process of uploading the data stream to the OLT may be described as (11). Firstly, in the wireless domain, the STA selects the nearest MAP node as the source node. Then, the source node MAP arrives at the gateway ONU through wireless multi-hop, which requires route planning. Finally, in the optical domain, the ONU has only a unique tree-shaped path to the OLT. Therefore, we need to route the service from the source node MAP to ONU.

$$STA \xrightarrow{\text{Choose the nearest}} MAP \xrightarrow{\text{Need to be planned}} ONU \xrightarrow{\text{TDMA}} OLT \quad (11)$$

In order to make the lower load ONUs and MAPs collaborative sleep to reduce network energy consumption, this paper proposes a regional division strategy for assigning a default ONU gateway to each MAP. By enabling services to be transmitted within the region, network congestion can

be avoided. Furthermore, we perform end-to-end routing of multi-level services based on priority in the region to ensure service quality.

1) Network region division based on load balancing

Before services arrive, we perform the network region division to reduce the service waiting time. Assuming that the total number of ONU_i in the FiWi network is $N_{ONU}, i \in \{1, 2, \dots, N_{ONU}\}$, and the total number of wireless node MAP_j in the network is $M_{MAP}, j \in \{1, 2, \dots, M_{MAP}\}$. The division relationship between MAP_j and ONU_i is represented by MAP_{ji} . If $MAP_{ji}=1$, it means that MAP_j is in the region centered on ONU_i ; and if $MAP_{ji}=0$, they are not in the same region. The network region division needs to divide the MAPs without overlap and omission in each region centered on the ONU, which can be expressed as (12).

$$\sum_{i=1}^{N_{ONU}} MAP_{ji} = 1, j \in \{1, 2, \dots, M_{MAP}\} \quad (12)$$

The other constraint is that the number of hops of the MAP multi-hop to the ONU in the local region does not exceed the threshold, which can be described by (13).

$$Hops_{ji} (\text{Hops from } MAP_j \text{ to } ONU_i) < Hops_{lim} \quad (13)$$

Considering load balancing, since the terminal STA selects the nearest MAP node as the service source by default, the distribution of MAP nodes in the region basically represents the distribution of the load. The network regions should ensure that the difference in their number of MAPs served by the ONUs cannot be too large, so as to avoid network congestion. Assuming that $S_{ONU-MPP_i}$ is the number of MAPs in the i -th ONU region, and its average value can be calculated by (14).

$$AVG(S_{ONU}) = \frac{\sum_{i=1}^{N_{ONU}} S_{ONU_i}}{N_{ONU}} = \frac{\sum_{i=1}^{N_{ONU}} \sum_{j=1}^{M_{MAP}} MAP_{ji}}{N_{ONU}} \quad (14)$$

In order to have a small difference in the number of MAPs in each region, we take the following measures: (1) We initially divide each MAP node into the nearest ONU region. (2) We select the MAPs that are farthest from the ONU in the region where the number of MAPs exceed the average to re-divide regions. (3) The hops of the MAPs reaching the new region should be within the threshold.

2) Intra-region route planning based on priority

After the region division is completed, when the service requests arrive, they need to be routed in each region. To ensure the QoS requirements of the service, we first prioritize different types of services, then perform service route planning according to the priority order.

a) Service levels division and priority calculation

This paper considers three different types of services with typical characteristics of the access network, namely EF-level, AF-level and BE-level services [19-20].

- EF (Expedited Forwarding): The EF service has high reliability requirements and is sensitive to delays, such as remote control and protection services.
- AF (Assured Forwarding): The AF service has high bandwidth requirements, high latency requirements,

and low reliability requirements, such as streaming video and video surveillance services.

- BE (Best Effort): The BE service has high reliability requirements, low latency requirements, and low bandwidth requirements, such as smart meter reading services.

Corresponding to a specific service, a service request can be represented by a quintuple: $SR(SR_{cpu}, SR_{band}, SR_{delay}, r_H, b_H, t_L)$, where $SR_{cpu}, SR_{band}, SR_{delay}$ are the CPU demand, bandwidth requirement, and maximum tolerable delay, respectively. By comparing with the service demand parameter threshold, it can be determined whether the SR has high reliability requirements, high bandwidth requirements, or low delay requirements, which are respectively denote by r_H, b_H, t_L , and if yes, the value is 1, otherwise it is 0. Therefore, the parameters of the three type services can be obtained as: (1) EF service ($r_H=1, b_H=0, t_L=1$); (2) AF service ($r_H=0, b_H=1, t_L=1$); (3) BE service ($r_H=1, b_H=0, t_L=0$).

We define the formula for service priority as (15).

$$QoS(SR) = r_H t_L + (1 - r_H t_L) (P_C \times SR_{cpu} + P_B \times SR_{band} + P_D \times SR_{delay}) \quad (15)$$

Where, if $r_H t_L=1$, the service is an EF-type service with the highest priority and its $QoS(SR)$ value is 1; if $r_H t_L=0$, the service is not an EF-type service, and the priority is calculated according to various parameters of the service. P_C, P_B, P_D are the weighting factors of CPU computing power, link bandwidth and tolerance delay, respectively. The calculated range is $0 < QoS(SR) < 1$. Service routing is performed according to the priority $QoS(SR)$ from high to low in each network region, so as to obtain the maximum benefit of network services.

b) Route planning for multi-level services

In the route planning process, we adopt a link-oriented protocol to exchange the control information in the FiWi network. The node informs its own link state to the network, and also collects others' information to generate a routing table and assign path weights. Assuming that there are X paths between the source node S and the destination node D for a service. The weight of each path between S and D is defined as $W_x (1 < x < X)$. Firstly, any optional path needs to meet the link bandwidth requirements and service delay requirements of the service. Then, we select the path with largest weight W_x in the optional paths to perform service transmission.

- Bandwidth constraints

It is assumed that the x -th path contains Y links, that is, the path contains Y hops. The y -th link has a rated capacity of BW_{xy} , and the link load is LD_{xy} . Thus, the minimum value of the difference between the link rated capacity and the load in the entire path is the remaining bandwidth of the path, which can be expressed as (16).

$$BL_x = \min(BW_{xy} - LD_{xy}), \quad y = 1, \dots, Y \quad (16)$$

The remaining bandwidth of each link in the optional path BL_x should be greater than the bandwidth required SR_{band} , which can be described by (17).

$$BL_x \geq SR_{band} \quad (17)$$

- Delay constraint

The delay constraint is that the total delay of all links on the optional path from the source node to the destination node should be less than the tolerance delay of the service request, which can be expressed as (18).

$$\sum_{y=1}^Y d_{xy} \leq SR_{delay} \quad (18)$$

Where d_{xy} represents the single-hop delay of the y -th link in the x -th path, and SR_{delay} denotes the tolerance delay of SR.

- Path weight calculation

In all the multiple candidate paths that meet the bandwidth and delay requirements, we calculate the path weights based on multiple factors such as the delay of the path, the remaining bandwidth and the packet loss rate. The path weight is used as a parameter to select the path. The greater the weight, the greater the probability that the path is selected, and the path weight is expressed as (19).

$$W_x = \frac{\left(\prod_{y=1}^Y (1 - LR_{xy}) \right)^{r_H} \times BL_x^{b_H}}{\left(\sum_{y=1}^Y d_{xy} \right)^{t_L}} \quad (19)$$

Where, LR_{xy} and d_{xy} indicate the packet loss rate and delay of the y -th link in the x -th path, respectively. BL_x denotes the minimum remaining bandwidth of the x -th path. For EF-type services such as remote real-time control service ($r_H=1, b_H=0, t_L=1$), the path weight calculation uses the packet loss rate and delay as the parameters. For AF-type services such as video service ($r_H=0, b_H=1, t_L=1$), the path weight calculation takes the bandwidth and the delay as the parameter. For BE-type services such as smart meter reading service ($r_H=1, b_H=0, t_L=0$), the path weight calculation uses the packet loss rate as the parameter, thereby implementing path selection for distinguishing service QoS. The entire service route planning mechanism based on load balancing and priority is shown as Algorithm 1.

Algorithm 1: Service route planning mechanism based on load balancing and priority

Node set N^S , Link set L^S ,
Input: $Loc(ONU_i), i \in \{1, 2, \dots, N_{ONU}\}$,
 $Loc(MAP_j), j \in \{1, 2, \dots, M_{MAP}\}$,
Service Request $SR_k (SR_{cpu}, SR_{band}, SR_{delay}, r_H, b_H, t_L), k \in \{1, 2, \dots, K\}$;
Output: Regional division: $MAP_j (MAP_j$ is divided in region $ONU_i)$,
Path for all SR_k ;

1. **Initialization:** $MAP_{ji} \leftarrow 0, i \in \{1, 2, \dots, N_{ONU}\}, j \in \{1, 2, \dots, M_{MAP}\}$;
2. **Regional division based on load balancing:**
3. **for** $j=1$ to M_{MAP} **do**
4. Divide MAP_j to the region ONU_i of the minimum hops count initially, mark as $MAP_{ji} = 1$;
5. **end for**
6. Sort the number S_{ONU_i} of MAPs in each region in descending order and calculate the average value.

7. **for** ONU_i region: $S_{ONU_i} > AVG(S_{ONU})$ **do**
8. Select the farthest MAP_j to re-partition;
9. **for** all $ONU_i (t \neq i)$ to MAP_j from near to far **do**
10. **if** $Hops_{jt} < Hops_{lim} \ \& \ S_{ONU_i} < AVG(S_{ONU})$ **then**
11. $MAP_{ji} = 0, MAP_{jt} = 1, S_{ONU_i} ++, S_{ONU_t} --$;
12. **break**;
13. **end if**
14. **end for**
15. **Route planning based on priority:**
16. Calculate the priority $QoS(SR_k)$ for all SR_k by (15);
17. Sort all SR_k s in descending order of $QoS(SR_k)$;
18. **for** each SR_k in sorted queue **do**
19. Find all $path_x, x \in \{1, 2, \dots, X\}$ from $S(SR_k)$ to $D(SR_k)$
20. each $path_x$ consists of Y links, each link $y \in \{1, 2, \dots, Y\}$;
21. **for** each $path_x$ **do**
22. **if** $\min(BW_{xy} - LD_{xy}) \geq SR_{band} \ \& \ \sum_{y=1}^Y d_{xy} \leq SR_{delay}$ **then**
23. Calculate the weight of the path W_x by (19);
24. **else** $W_x = 0$;
25. **end if**
26. **end for**
27. Output the path with largest W_x and transmit SR_k ;
28. Update remaining network resource information;
29. **end for**

B. collaborative region sleep mechanism between cross-domain nodes based on load transfer

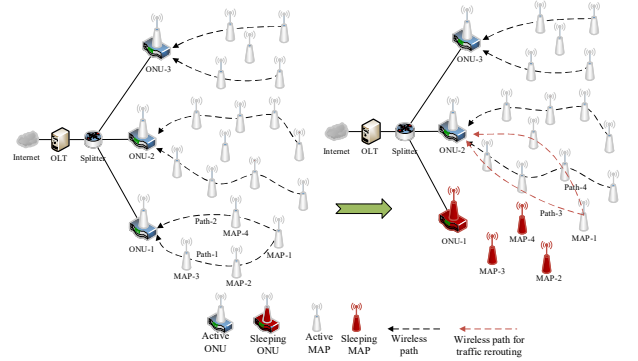

Fig. 2. Collaborative region sleep mechanism based on load transfer

In order to reduce the energy consumption of the FiWi network when the load is small, this paper proposes a collaborative sleep mechanism between the ONU and wireless nodes based on load transfer. As shown in Fig. 2, the mechanism first sleeps the ONU with lower load and the MAPs in the region, and re-divides the affected service and its source node MAP into the active ONU region. Secondly, in the new region, the affected service is re-allocated end-to-end route based on service priorities.

1) ONU and MAPs collaborative region sleep

We execute the sleep mechanism in every polling period T_{cy} of OLT to prevent frequent switch form on and off status. Firstly, we set the load Low Threshold (LT) and High Threshold (HT) in T_{cy} time of each ONU region to control

whether to sleep/wake the network region. The active network region load total B_i must be between LT and HT, which can be expressed by (20).

$$LT < B_i = \sum_{m=1}^{N_{mi}} B_{mi} < HT, i \in \{1, 2, \dots, N_{ONU-MPP}\} \quad (20)$$

Where, B_{mi} denotes the load of the m -th service in the ONU_i region, and N_{mi} indicates the number of services in the region. This limitation prevents the network region from being overloaded or the situation that less service transmissions occupy too much network resources. The following contents discuss the situation where the total region load exceeds the threshold.

a) If $B_i < LT$

When the total network region load B_i is lower than LT, we consider re-dividing the service and the service source node MAP into other network regions, so as to make ONU and the remaining MAPs sleep in current region. During the load transfer, in order to improve the connectivity of the wireless router, the primary relay node MAPs can also reselect the new region like the service source node. The way to selection is as follows:

- The load B_k of the new target ONU region plus load B_m of service source node MAP_m is still within the specified threshold range, as shown in (21).

$$LT < B_k + B_m < HT \quad (21)$$

- The selection of new target region takes into account the regional load capacity and the distance from the service source node MAP to the new gateway. We define the weight G_k for selection as (22).

$$G_k = (C_g - B_k) / L_{m,k} \quad (22)$$

Where, C_g and B_k are the rated capacity and current load of the new region, respectively. $L_{m,k}$ is the distance from MAP_m to the new gateway ONU_k . In all new network regions that meet the load capacity constraints, the region with the largest G_k is selected for the load and service source node MAP. After network regions are reconstructed, the ONU of the original region and remaining MAPs are dormant.

b) If $B_i > HT$

When the total network region load B_i is higher than the high threshold HT, we also re-divide some service source nodes to avoid network congestion. The new region reselection considers other active network regions first to increase the sleep time of the dormant regions. Similar to $B_i < LT$, some nodes reselect the target transfer network region according to formulas (21) and (22). If the active network region cannot meet the transfer requirement of the service source node, the dormant region is awakened.

2) Priority-based affected services rerouting

After completing the active/sleep transition of the FiWi network regions and reselecting the new region for the affected services, it is necessary to further complete the end-to-end reroute allocation for the transferred services in the new region. Since the original network load of the new

network region already occupies most network resources, it may not be able to meet the routing requirements of all the transferred loads. Therefore, this paper performs a priority-based load rerouting mechanism.

We first prioritize all the services that need to be rerouted and then transmit them according to the routing algorithm proposed by Algorithm 1 in order. If the remaining resources of the current network can be satisfied, the route is directly performed; and if it is not satisfied, we need to determine the current rerouting service level. If it is a EF-type service, the resources occupied by the low-priority SRs that have been successfully routed in the current network region need to be released to perform timely transmission of the EF-type service. The release mode is that the service with the lowest priority is selected to release the resource, and the expired one is not selected. If it is still not satisfied, the next service is released until the rerouting succeeds. The rerouting mechanism is shown in Fig.3. Firstly, SR1 and SR2 are transmitted. At the same time, the high priority protection service SR3 needs to be rerouted. Therefore, the low priority SR2 is released, and SR3 is rerouted.

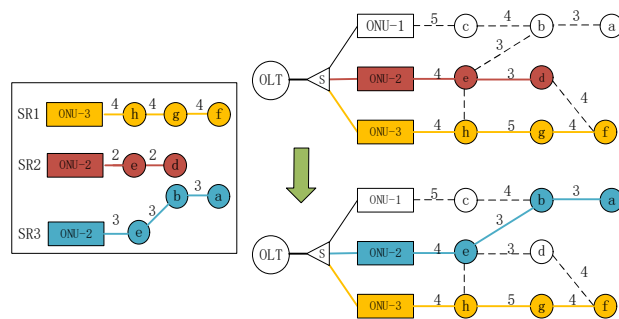

Fig. 3. Priority-based load rerouting mechanism

The entry process of collaborative region sleep mechanism between cross-domain nodes based on load transfer is described in details as Algorithm 2.

Algorithm 2: Cross-domain nodes collaborative sleep mechanism based on load transfer

Input: Load in the ONU_i region $B_i, i \in \{1, 2, \dots, N_{ONU}\}$
Low Threshold LT , High Threshold HT ;
Some ONUs or MAPs sleep, some affected services and their source nodes MAPs in the sleep region select new regions, the affected services rerouting within the new regions.

Output: source nodes MAPs in the sleep region select new regions, the affected services rerouting within the new regions.

1. **Regional sleep mechanism:**
2. **for each ONU_i network region do**
3. **if $B_i < LT$ then**
4. **for SR_m in the region to be dormant do**
5. **for each active $ONU_k (k \neq i)$ region do**
6. **if $LT < B_k + B_m < HT$ then**
7. Calculate the gateway weight $G_k = (C_g - B_k) / L_{m,k}$;
8. **else $G_k = 0$;**
9. **end if**
10. **end for**
11. Keep the source and primary relay MAPs active;
12. Select the ONU with largest G_k as new gateway;
13. **end for**
14. Send ONU_i and rest MAPs in the region to sleep;

```

15. else if  $B_i > HT$  then
16.   for each  $SR_m$  of loads beyond  $HT$  in the region do
17.     Take steps from 5 to 12;
18.     if  $G_k = 0$  for all active regions then
19.       Wake up and select the sleep region closest to  $SR_m$ ;
20.     end if
21.   end for
22. end if
23. end for
24. Affected services rerouting mechanism:
25. Sort  $SR_k$  in descending order of priority  $QoS(SR_k)$ ;
26. for each  $SR_k$  in sorted queue do
27.   Perform QoS-aware routing based on Algorithm 1;
28.   if resource can meet the  $SR_k$  requirements then
29.     Transmit  $SR_k$ ;
30.   else if  $QoS(SR_k) = 1$  then
31.     Prioritize SRs occupying resources in the region;
32.     for  $SR_k$  still cannot be transmitted do
33.       Release resources occupied by the lowest priority SR;
34.       Recalculate current remaining network resources;
35.     end for
36.     Transmit  $SR_k$ ;
37.   end if
38. end for

```

V. SIMULATION RESULTS AND ANALYSIS

A. parameter settings

The coordinate size of the FiWi network topology is set to be $50 \times 50 \text{ m}^2$, which consists of 1 OLT, 4 ONUs, and 20 MAPs. The ONUs are connected to the OLT in a star topology. The MAPs are randomly and evenly distributed in the grid region. The specific simulation parameters are shown in the TABLE I.

TABLE I. SIMULATION PARAMETER SETTINGS

Parameter setting	Parameter value
CPU processing power of ONU	400-500 uniform random distribution
CPU processing power of MAP	80-100 uniform random distribution
MAP to MAP, MAP to ONU Link bandwidth	20-40 uniform random distribution
Energy consumption of active ONU (W)	5.052
Energy consumption of sleep ONU	0.750
Energy consumption of active MAP	1.250
Energy consumption of sleep MAP	0.010
CPU requirements of service request	0-30 uniform random distribution
Bandwidth requirements of service request	0-5 uniform random distribution

In order to verify the effectiveness of the proposed algorithm, it is compared with other typical energy-saving mechanisms, including the EASLO algorithm proposed in [10] and the BGW algorithm proposed in [5]. The same as the algorithm proposed in this paper, both EASLO and BGW algorithms perform the sleep/active transitions of ONU by setting the load threshold. The difference is that the EASLO algorithm uses the shortest path algorithm to allocate routes for services. While the BGW algorithm sets the path weight according to the links capacity and adds the hop limit to allocate routes for the services. But none of them involve the

energy saving of wireless routers. Our collaborative sleep mechanism between cross-domain nodes in FiWi network based on load balancing and QoS awareness (In the following text, we call it SLBQA) proposed in this paper takes the regional dormancy of ONU and wireless nodes into account, and combines the quality of service guarantee. Our algorithm complexity is $O(n^2)$, and we also take pre-process and periodic operation to achieve less overhead.

B. Simulation result analysis

Through long-term online request arrival route simulation, we regularly sample and monitor various performance indicators and obtain the following simulation results.

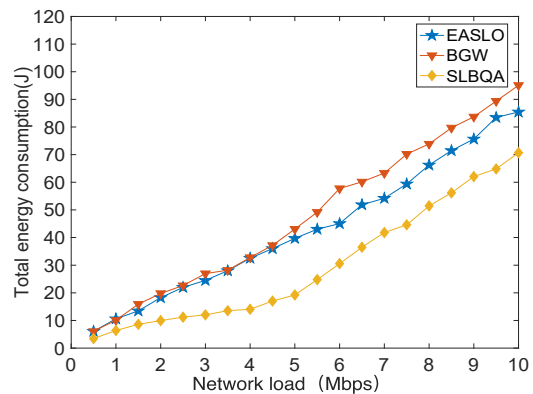

Fig. 4. Total energy consumption with different algorithms

Fig. 4 shows the total energy consumption of the three algorithms in the FiWi network. The ordinate is the total energy consumption and the abscissa is the network load rate. It can be seen that among the two algorithms only sending the ONUs sleep, the EASLO algorithm uses the shortest path algorithm on the route, which is more energy efficient than the BGW algorithm using the maximum remaining bandwidth algorithm, because the former has fewer forwarding nodes. The SLBQA algorithm proposed in this paper allows both the ONUs and the wireless nodes to sleep, so it has significant energy saving effect compared with other two algorithms. We can also find that the rate at which the energy consumption increases becomes larger as the load rate increases. This is because when the load rate is low, the ONU sleep ratio is large and the energy consumption is low. As the load rate increases, the ONU sleep ratio is smaller, so energy consumption increases rapidly, indicating the energy-saving effect of dormancy.

Fig. 5 shows the transmission success number of the three algorithms in the case of meeting the service tolerate delay requirement. We set up a 2000 service requests queue to count the number of successfully transmitted services and the number of high-priority services. It can be seen from the figure that the number of successfully transmitted services of the SLBQA algorithm in this paper is 1301, which is 109 and 205 more than the number of BGW algorithm and the EASLO algorithm, respectively. It can be seen that our network region division method and route planning method based on the maximum remaining bandwidth are beneficial to ensuring continuous operation of the network and improving service transmission. Besides, since our SLBQA algorithm performs service prioritization, the high-priority services are transmitted first and they have a higher percentage of successful transmissions.

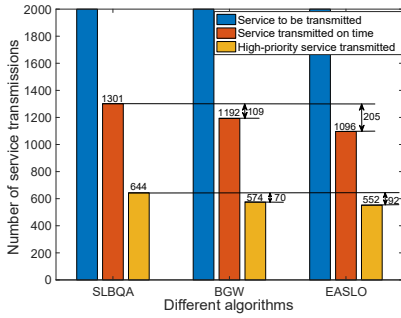

Fig. 5. Number of service transmissions

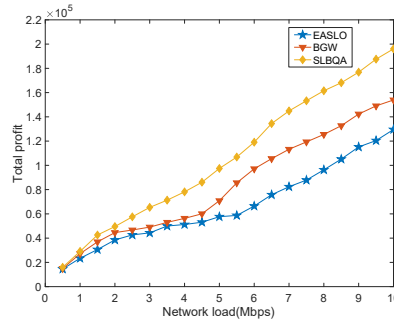

Fig. 6. Total revenue from network services

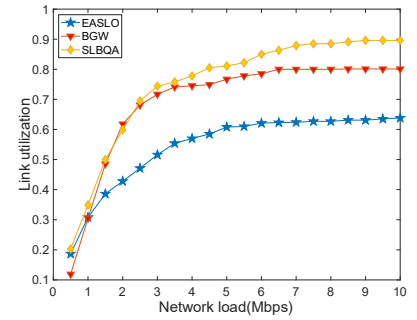

Fig. 7. Link bandwidth utilization

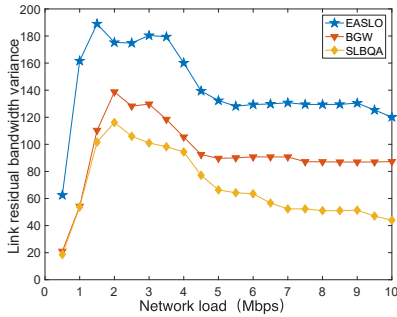

Fig. 8. Link residual bandwidth variance

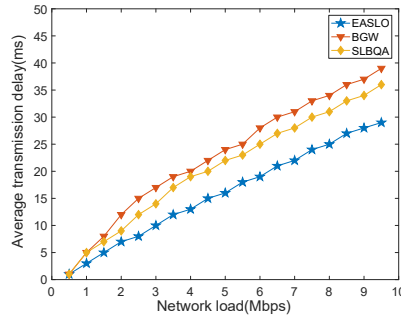

Fig. 9. Service average transmission delay

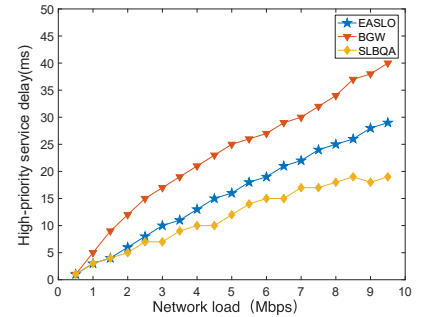

Fig. 10. High-priority service transmission delay

Fig. 6 shows the total profit of services transmission of the three algorithms. It can be seen from the figure that when the load rate is low, the profit of the three algorithms are not much different. This is because the network is relatively smooth at this time, their energy consumptions and transmission rate are not much different. However, as the load rate increases, the SLBQA algorithm of this paper obtains the largest profit. According to the previous analysis, when the load rate is large, the SLBQA algorithm has the lowest energy consumption, the highest service transmission rate, and the highest proportion of high-yield high-priority services, so as to obtain the maximum profit.

Fig. 7 and Fig. 8 show the bandwidth utilization and the residual bandwidth variance of the links under the three algorithms, respectively. As can be seen from the two figures, the EASLO algorithm has the lowest link bandwidth utilization and the largest variance. Because it uses the shortest path algorithm, which quickly causes the load of the network links to be unbalanced. As the load increases, it is difficult to find the shortest path in the unbalanced network. The BGW algorithm uses the maximum remaining bandwidth routing mode to ensure better network load balancing, higher link bandwidth utilization and lower variance. Our SLBQA algorithm performs service routing in each region to further ensure the smoothness of the network, and can fully utilize the remaining resources, so that it obtains the highest link bandwidth utilization and the lowest variance.

Fig. 9 and Fig. 10 show the average transmission delay of all services and the transmission delay of the high-priority service, respectively. It can be seen from the figure that the EASLO algorithm using the shortest path planning method has the lowest delay, while the BGW algorithm has the largest delay. Our SLBQA algorithm combines the remaining bandwidth and path length to select paths, so that

the average delay is lower than the BGW algorithm and higher than the EASLO algorithm. However, our SLBQA algorithm performs QoS-aware hierarchical service queuing transmission control, which prioritizes high-priority services, and uses path delay as the main reference factor in high-priority service route planning. Therefore, the high priority delay of the SLBQA is the lowest, and the QoS of the high priority service is preferentially satisfied.

To sum up, the SLBQA algorithm proposed in this paper has better performance in energy saving, network load balancing and service QoS guarantee.

VI. CONCLUSION

In order to save energy and ensure QoS, this paper studies the collaborative sleep mechanism between cross-domain nodes in FiWi network based on load balancing and QoS awareness. It consists of two sub-mechanisms which are used to allocate route and implement energy saving. First, we study the service route planning mechanism based on load balancing and priority to properly cluster nodes and select the end-to-end route for different services. Then, we present the cross-domain nodes collaborative sleep mechanism based on load transfer to select nodes to sleep and re-allocate routes for the affected services according to the service priority. The simulation results show that the SLBQA algorithm proposed in this paper can achieve high transmission rate and low latency for high priority services while effectively saving energy. At the same time, the algorithm implements network load balancing and ensures continuous operation of the network.

ACKNOWLEDGMENT

This work is supported by National Key R&D Program of China (2016YFB0901200).

REFERENCES

- [1] Maier, Martin. "Fiber-Wireless (FiWi) Broadband Access Networks in an Age of Convergence: Past, Present, and Future." *Advances in Optics*, 2014, pp. 1-23.
- [2] Van, Dung Pham, et al. "ECO-FiWi: An Energy Conservation Scheme for Integrated Fiber-Wireless Access Networks." *IEEE Transactions on Wireless Communications* 15.6(2016), pp. 3979-3994.
- [3] Fadlullah, Zubair Md., et al. "Smart FiWi Networks: Challenges and Solutions for QoS and Green Communications." *IEEE Intelligent Systems* 28.2(2013), pp. 86-91.
- [4] Van, Dung Pham, et al. "Design, Analysis, and Hardware Emulation of a Novel Energy Conservation Scheme for Sensor Enhanced FiWi Networks (ECO-SFiWi)." *IEEE Journal on Selected Regions in Communications* 34.5(2016), pp. 1645-1662.
- [5] Chowdhury, Pulak, et al. "Building a Green Wireless-Optical Broadband Access Network (WOBAN)." *Journal of Lightwave Technology* 28.16(2010), pp. 2219-2229.
- [6] Ghazisaidi, Navid, and M. Maier. "Fiber-wireless (FiWi) access networks: Challenges and opportunities." *IEEE Network* 25.1(2011), pp. 36-42.
- [7] Liu, Jiajia, et al. "New Perspectives on Future Smart FiWi Networks: Scalability, Reliability, and Energy Efficiency." *IEEE Communications Surveys & Tutorials* 18.2(2017), pp. 1045-1072.
- [8] Rimal, Bhaskar Prasad, et al. "Machine-to-Machine Communications Over FiWi Enhanced LTE Networks: A Power-Saving Framework and End-to-End Performance." *Journal of Lightwave Technology* 34.4(2016), pp. 1062-1071.
- [9] Liu, Jiajia, et al. "Energy Consumption Minimization for FiWi Enhanced LTE-A HetNets with UE Connection Constraint." *IEEE Communications Magazine* 54.11(2016), pp. 56-62.
- [10] Liu, Ye Jun, et al. "A new integrated energy-saving scheme in green Fiber-Wireless (FiWi) access network." *Science China (Information Sciences)* 57.6(2014), pp. 62307-062307.
- [11] Gong, Xiaoxue, et al. "Dynamic energy-saving algorithm in green hybrid wireless-optical broadband access network." *Optik - International Journal for Light and Electron Optics* 124.14(2013), pp. 1874-1881.
- [12] Han P, Guo L, Liu Y, et al. "Joint Wireless and Optical Power States Scheduling for Green Multi-Radio Fiber-Wireless Access Network." *Journal of Lightwave Technology*, 2016, 34(11), pp. 2610-2623.
- [13] Liu, Xin, et al. "On the Tradeoff Between Energy Saving and QoS Support for Video Delivery in EEE-Based FiWi Networks Using Real-World Traffic Traces." *Journal of Lightwave Technology* 29.18(2011), pp. 2670-2676.
- [14] Correia, N., G. Schutz, and A. Barradas. "Correlation-based energy saving approach for smart fiber wireless networks." *IEEE/OSA Journal of Optical Communications & Networking* 7.6(2015), pp. 525-539.
- [15] Togashi, K, et al. "On the effect of cooperation between power saving mechanisms in WLANs and PONs." *IEEE International Conference on Communications IEEE*, 2013, pp. 6225-6229.
- [16] Dhaini, Ahmad R., P. H. Ho, and S. Abdallah. "Performance Evaluation of QoS-Aware Layer-2 VPNs over Fiber-Wireless (FiWi) Networks." *IEEE Globecom* 45.2(2010), pp. 1-6.
- [17] Han, Pengchao, et al. "A new virtual network embedding framework based on QoS satisfaction and network reconfiguration for fiber-wireless access network." *IEEE International Conference on Communications IEEE*, 2016, pp. 1-7.
- [18] Ming, Ann Ng, and K. L. A. Yau. "An energy-efficient Hybrid Wireless Mesh Protocol (HWMP) for IEEE 802.11s mesh networks." *IEEE International Conference on Control System, Computing and Engineering IEEE*, 2014, pp. 17-21.
- [19] Ghazisaidi, Navid, M. Maier, and M. Reisslein. "VMP: A MAC Protocol for EPON-Based Video-Dominated FiWi Access Networks." *IEEE Transactions on Broadcasting* 58.3(2012), pp. 440-453.
- [20] Xu, Yun, and Y. Li. "ONU patching for efficient VoD service over Integrated Fiber-Wireless (FiWi) access networks." *IEEE International ICST Conference on Communications and NETWORKING in China*, 2012, pp. 1002-1007.