

The Research of Embedded Remote Monitoring System Based on B/S Framework

Xiaoyan Cheng, Guoqing Dang
School of mechanical engineering Xinyu University
Xinyu 338004, China
chenxiaoyuan@yeah.net



ABSTRACT: *The embedded remote monitoring system is based on embedded technology, video coding technology and network transmission technology as the core of the new video surveillance system, it in real-time monitoring system, network, miniaturization, etc than traditional remote monitoring system has outstanding advantages. The embedded server is responsible for the data from field devices and video images, and real-time and reliable transmission to the remote client browser. User through a PC browser login system, can get equipment real-time data and video image, also can control the equipment, so as to realize remote monitoring. This paper designed and implemented a embedded remote monitoring system based on B/S structure, is of important engineering value. The result showed that the new embedded remote monitoring system can help more projects to realize the remote control, reduce the cost of personnel, and finally increase the efficiency of the engineering. At the same time, it can help users to achieve remote supervision idea.*

Keywords: Monitoring System, Embedded System, B/S Framework.

Received: 15 September 2016, Revised 17 October 2016, Accepted 21 October 2016

© 2017 DLINE. All Rights Reserved

1. Introduction

With mature embedded technology and network technology, industrial equipment to realize network management has become a trend. Build a remote monitoring system can effectively solve concentration caused by the distributed monitoring equipment management difficult problem[1]. Using B/S pattern design of the embedded technology is a hot spot in the embedded remote monitoring system, this design method has changed the previous monitoring system architecture, can meet the requirements of remote monitoring system, has the very broad application prospects [2]. At present, the embedded system has been in the military, industrial, life, entertainment and other fields in a wide range of applications. Remote monitoring technology is to point to the local computer system such as the Internet/Intranet, through the network to monitor and control of field devices, realize the distributed control network of equipment condition monitoring and diagnosis of maintenance, and other functions, it combines computer technology, network technology and control technology into an organic whole, with strong control function, simple operation and high reliability etc [3]. Through remote monitoring, it can realize real-time quantitative field

equipment data set and transmission, monitoring and control system and field production equipment running status and various parameters, so as to realize the unattended of some dangerous or special occasions, to save a lot of manpower material resources. There are generally two types of traditional video monitoring system, a class of closed-circuit television monitoring, monitoring area is limited, the lack of intelligence, to a great extent, still need to depend on the person's subjective judgment, often leads to false positives, omission phenomenon; Another kind of digital surveillance based on ordinary PC, although can provide good monitoring solution for the customer, but the volume is larger, usually video monitoring front-end design is relatively complex, great power consumption, stable enough[4].

Based on B/S structure of the embedded remote monitoring refers to the site with an embedded server, is responsible for the data collection of field devices, storage, and interaction between host and remote monitoring of data, field devices with embedded server can be directly connected to the Internet/Intranet, no additional set of data calculation and control equipment[5]. Because the embedded hardware device has small volume, low cost, high reliability, strong stability and low power consumption, embedded operating system can carry on the rational distribution of multiple tasks, thus improve the speed and stability of the entire system [6].

2. The system structure of B/S

Structure of B/S (Browser/Server and Browser/Server mode), is one of the WEB after the rise of the network structure model, a WEB Browser is one of the main client application software [7]. This model unifies the client, will be the core of the system function realization part focus on the server, simplify the development, maintenance and use of the system. The client as long as the installation of a browser, like Netscape Navigator or Internet Explorer, Server install SQL Server, Oracle, MYSQL database, etc. Browser data through the Web Server and database interactions [8].



Figure 1. Remote monitoring system of operation room

B/S (Browser/Server) mode is a kind of three layer or multilayer structure of distributed system, and is consisted by the Browser (Browser) and Server (Server). The Server includes a Web Server, database Server, application Server, such as its structure as shown in figure 1 [9]. In this mode, at the request of the client to the Web Server via a Browser by the Web Server to the database Server query request, a Web Server to query data in the form of a hypertext document to the Browser. B/S mode application system is a kind of thin client, the client using a single Browser software, hardware configuration requirements is not high; Easy to manage and maintain the system, software development, upgrade and maintenance on the server side only, reduced the development and maintenance work; The system does not need to develop the client software, web browser software can free download from the Internet, free upgrade; The system protection enterprise investment, B/S mode using standard TCP/IP,

HTTP protocol, can be combined with the enterprise existing network well[10]. At the same time it has good expansibility, can directly connect the Internet. So B/s mode with its easy to use, easy to maintain, high degree of information sharing are gradually replacing C/S mode [11]. Embedded web server is the core node of the remote monitoring system, limited to the length of this article only discusses the embedded web server involved in the process of some key technologies in this layer.

Advantage of B/S is, first of all, it simplifies the client. It need not like C/S mode in different client installed on different client application. Second, it simplifies the development and maintenance of the system [12]. System developers need not again for different levels of user application design and development of different customers, just put all the function of the realization on a Web server, and the different function set permissions for each group of users. Individual users via HTTP request within the scope of authority call different handler on the Web server, so as to complete the data query or modify [13]. What is more, it also makes users' operation easier.

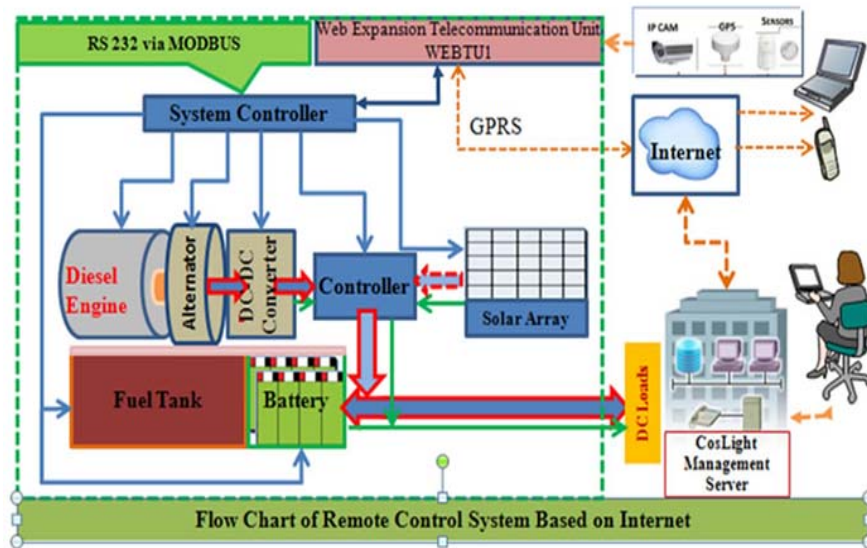

Figure 2. The remote monitoring system for monitoring picture

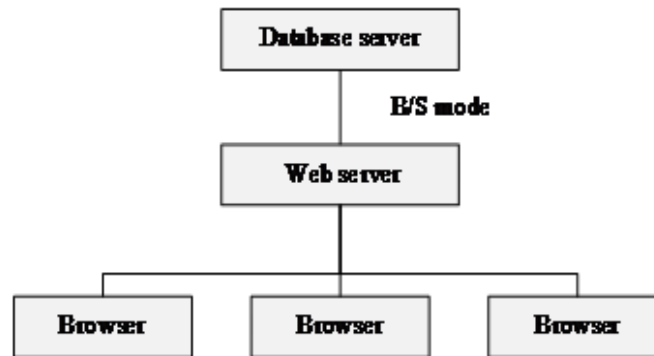

Figure3. System structure of B/S

3. The overall architecture of the embedded remote monitoring system

An embedded remote monitoring system USES a client/server (c/s) mode. By simplifying TCP/IP protocol stack for embedded web server (ews) function. Install the ews to the equipment, so as to make the embedded devices can through the Internet Internet, at the same time can provide network management page, user can use a standard web browser to many online remote access equipment, control and management, limit of time and distance to a minimum[14].

Embedded technology has been widely used in remote monitoring system, it is based on the application as the center, computer technology, software and hardware can be cut, is suitable for the application system of cost, volume, function, reliability, power consumption have strict requirements of special computer system, it is mainly composed of embedded processor and related support hardware, embedded operating system and application software. This paper implements a based on B/S architecture of embedded remote monitoring system of the Web. Server using ARM classic S3C2410 development platform, the user through the client browser login system, based on the development board data real-time query, control of the equipment CAN operate equipment and remote video monitoring module in so as to achieve the purpose of remote monitoring. Clients use ordinary PC browser connection through the network, IP address access development board login system, authentication success, into the monitoring system to monitor the main page. This system has good security, able to respond to the client's query and control request. Figure 4 is the physical structure of the system.

System is divided into the remote customers browse station, monitor center and local monitor server group. Among them, the monitoring server group is composed of multiple monitoring server (monitor), each monitor can work independently. Monitor through the open network connected; Local monitoring center by the unit into an ordinary PC, through local area network (LAN) connected to the monitor; Remote viewing stand through a Web browser to enter the IP address of the remote control, monitoring the related page, real-time monitoring of the scene. Here, the monitoring server is a data acquisition, data transmission and intelligent processing of a microcomputer system.

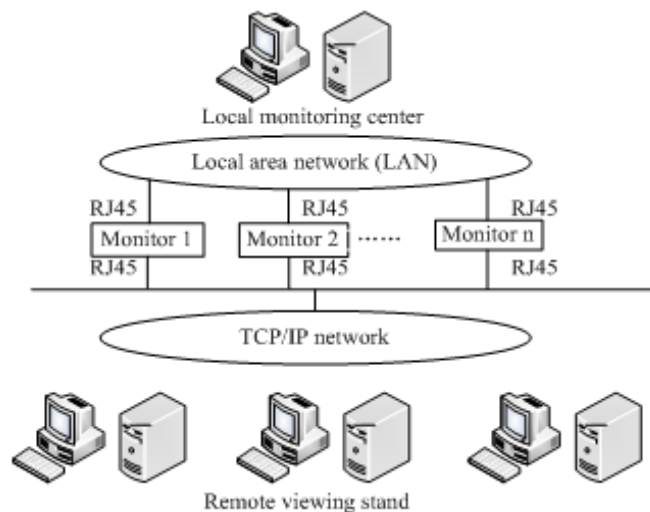

Figure 4. Physical structure diagram of the system

4. Embedded remote monitoring system platform design based on b/S

With the rapid development of Internet technology, embedded systems are significantly in the direction of intelligent, networked. At the same time, the development of Web technology makes embedded system more convenient to access the Internet. The wide application of Web technology, prompted the B/S model directly. The characteristics of the B/S model is the main application on the server, the client only need to use normal browser, can be downloaded from the server application to complete the corresponding task. But since the embedded system with limited resources, in order not to affect the overall performance of the embedded system, the traditional Web server must to use cut-outs. Development of remote monitoring system, this paper is to establish on the basis of the information network and control network integration, achieve the real time communication system, the user can in the browser to send and receive real-time data. Use dynamic web publishing data, make the client browser can dynamically display the network data and control the operation state of the object.

The embedded remote monitoring system platform based on b/S architecture is shown in figure 5. According to the general management system software design pattern, can be divided into three layers: the monitoring software structure system client layer, middle server layer and control layer. In monitoring software system, the remote users either through B/S structure of web server network are connected to the Internet communicate with the server.

The embedded remote monitoring system based on B/S architecture hardware platform using embedded microcontroller processor, operating system software USES the network powerful Linux operating system. In order to realize the function, the overall design of the embedded remote monitoring system can be divided into three layers structure: hardware layer is made up of minimum system based on microprocessor and peripheral interface unit. Minimum system includes CPU, memory cell, reset circuit, power management system, the clock circuit, real-time clock. Peripheral interface unit includes man-machine interface, GPRS wireless module, network interface, USB interface, etc. Software layer includes starting Linux Bootloader, Linux operating system of the operating system and embedded file system. Function layer by calling the software interface provided by the operating system in the B/S architecture in a server application. Embedded remote monitoring system based on B/S architecture design of the key technology is the design of remote monitoring service software implementation.

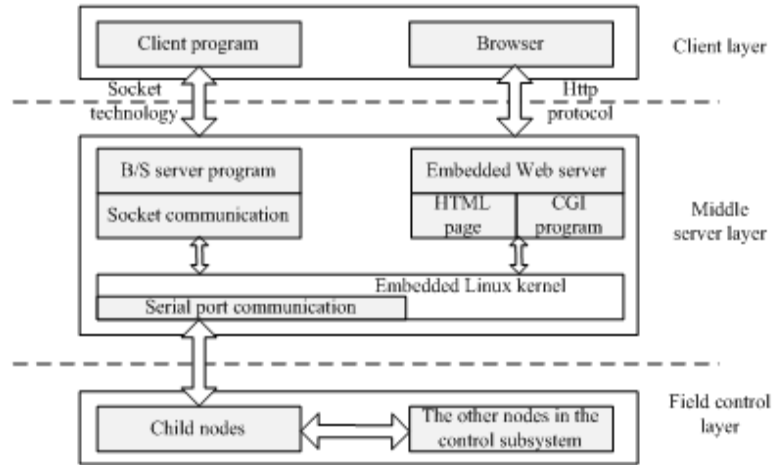

Figure 5. The embedded remote monitoring system platform based on b/S architecture

5. Conclusion

With the continuous development of network technology, the technology of the Internet has penetrated into every field of daily life and industrial production, which makes the remote monitoring of various equipment operation is possible. Embedded remote monitoring system with its small size, low power consumption, long working hours, stable performance, etc, become the mainstream direction of remote monitoring system, embedded Web technology has more and more widely in the field of embedded remote monitoring application prospect, and plays a more and more important role. So this article research has realized based on B/S architecture of embedded remote monitoring system of Web, the B/S mode is introduced into the monitoring system, the analysis of the BS/model remote monitoring system of main technology, this paper builds a typical mode of BS/remote monitoring system platform, has wide application prospect. To help more the purpose of the project to realize the remote control, reduce the cost of personnel, increase the efficiency of the engineering.

References

- [1] Ganeriwal, S., Balzano, L.K., Srivastava, M.B. (2008). *ACM Transactions on Sensor Networks (TOSN)*. 4 (3) 15.
- [2] Muller, A., Crespo Marquez, A., Jung, B. (2008). *Reliability Engineering & System Safety*. 93 (8) 1165.
- [3] Raja, S., Babu, G.S. (2011). *International Journal of Technology and Engineering system (IJTES)*. 2 (2) 35.
- [4] Zhao, Q. (2011). *Journal of Software*. 6 (5) 814
- [5] Hobby, M., Gascoyne, M., Marsham, J.H. (2013). *Journal of Atmospheric and Oceanic Technology*. 30 (4) 709.
- [6] Fang Hong-ping, Fang Kang-ling. (2009). Design and Research of the Remote B/S Monitoring System Based on Embedded System. *Micro computer information embedded with SOC*. 25 (2) 3.
- [7] Decheng, Lou., Yin, Wei. (2014). The Design of Embedded Remote Video Monitoring System Based on B / S Mode, *Microcomputer Applications*. 30 (9) 37-83.

- [8] Dang, G .Q., Cheng, X .Y. (2015). The Research of Embedded Remote Monitoring System Based on B/S Framework. *Applied Mechanics & Materials*. 712 (3) 508-511
- [9] Wu, X., Li, B., Zhao, L. (2011). An embedded real-time remote monitoring system based on B/S mode, *In: Mechatronic Science, Electric Engineering and Computer (MEC), International Conference on. IEEE*. 34 (6) 2135-2138.
- [10] Hui, Xie., yu-bin, Xu. (2008). Based on the research of sqlite embedded data acquisition system with Design . *Computer and Digital Engineering* 4 (6) 91-94.
- [11] Qi Shiqian, Guo Maicheng. (2006). Based on embedded Linux network video monitoring system design, *Journal of Electronic Technology Applications*. 32 (4) 74-76.
- [12] Xi-huang, Zhang., Zhi-leii, Chai (2003). Characteristics and implementation of embedded Web server CGI, *Small microcomputer system*. 24 (11) 2046-2047.
- [13] Shen, M., Lio, Tzen G H (2003). Multi-criteria task assignment in workflow management systems, *In: 36th Hawaii International Conference on System Sciences*. 26 (4) 45-58
- [14] Su-fang, Liu., Kun, Luo. (2008). Remote network monitoring system based on ARM. *Microcomputer numerical machine Interest rates*. 24 (1-2) 166-167