

The Flight of the Boomerang Comments

Almudena Martín

Advanced Dynamics C.B., Madrid, Spain
Email: gestor@advanceddynamics.net

How to cite this paper: Martín, A. (2017)
The Flight of the Boomerang Comments.
World Journal of Mechanics, 7, 46-67.
<https://doi.org/10.4236/wjm.2017.73007>

Received: December 28, 2016

Accepted: March 20, 2017

Published: March 27, 2017

Copyright © 2017 by author and
Scientific Research Publishing Inc.
This work is licensed under the Creative
Commons Attribution International
License (CC BY 4.0).

<http://creativecommons.org/licenses/by/4.0/>



Open Access

Abstract

This text comprises a brief description and summary of **THE FLIGHT OF THE BOOMERANG**, in which for the first time its author, Gabriel Barceló, presented the **Theory of Dynamic Interactions** in a book (2006). This book proposes foundations for new hypotheses in rotational dynamics, which enable us to resolve issues that until today have been unthinkable, such as the anomalies of the *Pioneer probes*, the essence of dark matter, or the true structure of the cosmos. The **Theory of Dynamic Interactions**, is a conceptual structure that studies the behavior of rigid solid bodies endowed with angular momentum.

Keywords

Boomerang, Advanced Dynamics, Dynamic Interactions, Rotational Dynamics, Creative Curiosity, New Paradigm in Physics, Miguel Catalán, Gyroscope

1. Introduction

The first book published by Gabriel Barceló on dynamics was **THE FLIGHT OF THE BOOMERANG**, where he set out the various studies and experimental tests developed by the **Advanced Dynamics** research team. The text proposes a view of nature in which bodies endowed with intrinsic rotation do not behave in accordance with the laws of classical mechanics for bodies in motion.

In this way, the mechanics involved in the flight of a boomerang are simply explained, and also proposed, with a different and renewed vision, are the keys to interpret the behavior of Saturn's galaxies and rings.

And all of this can be achieved by simply looking anew at something which seemed obvious until now. As the author himself puts it in the book, ... *when ever analysing sense perceptions from a new perspective, keys to science can be revealed that have been overlooked by other researchers or experts, even those endowed with the best resources and most powerful means* [1].

The text proposes foundations for new hypotheses in rotational dynamics, which enable us to resolve issues that until today have been unthinkable, such as the anomalies of the *Pioneer probes*, the essence of dark matter, or the true structure of the cosmos. Overall, it is an unconventional piece of work that, even in its informative part, will be novel.

This book was, at that time, the result of more than fifteen years of development of a private research project with scarce resources, which suggested new dynamic theories that may be transcendental for the configuration of physics over the coming years. In this book he justifies and exposes a new paradigm of physics, which he calls the **Theory of Dynamic Interactions**, which he defines as: *A dynamic theory that determines the behavior of bodies endowed with angular momentum. It is based on the inertial inability of matter, in certain cases, to vectorially add resulting angular momentum and, in general, angular magnitudes of bodies in rotation. It allows the development of a specific dynamics of solids in rotation, subject to successive torques, in which the sequential action of forces and their behavior does not exactly match the laws of classical mechanics* [2].

The Flight of the Boomerang, has a prologue by Federico García Moliner, Prince of Asturias Award for Scientific and Technical Research. It is also a tribute to the Spanish scientist Miguel Catalán Sañudo (1894-1957), who is remembered by the international scientific community, which assigned his name to a group of craters on the Moon.

Subsequently the author has published two articles on the flight of the boomerang [3] [4] and has edited a video [5] with his experiences

2. Rotational Dynamics

On the basis of the concept of rotation, and after a historical analysis, the author defines the main magnitudes of rotational dynamics and the mathematical procedures used. But this conceptual development is based on conventions adopted as in **Figure 1**.

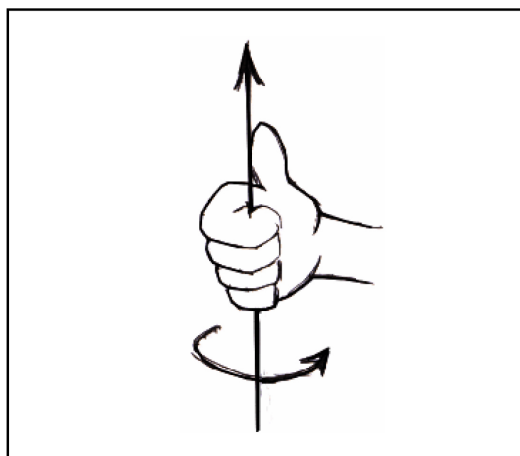

Figure 1. The convention to define the way of rotation: The positive way of rotation of an axis is determined by the right-hand rule or that of the corkscrew.

He proposes this definition: *Rotation is the geometric operation of positional change in relation to a reference axis. It can be performed on any axis and is defined by identifying the direction and sense of that axis, accepting the convention that is expressed in the figure.*

Adding that: *We can understand rotational dynamics as that part of dynamics, which deals with the laws of the movement of bodies that have an angular momentum in relation to the forces producing it. Starting from the axioms and principles that underlie classical mechanics, a set of derivative theorems are deduced. These theorems can refer to a material point, to systems of material points and rigid solids and constitute the structure of Newtonian formulation, based on the sensitive perception of human beings. On the other hand, formulations from analytical mechanics permit a more abstract structural development, which is removed from the direct relationship with what is appreciable [6].*

3. Creative Curiosity

The text begins with a comment on creative curiosity, with a proposal to *arouse scientific curiosity, observations and reasoning, questioning those axioms that could lead to doubt or confusion.* It extols the advocacy of inquisitive thought, implying the *maintenance of a concern for inquiry*, and criticism. It stimulates debate and encourages curiosity, the adventure of searching for the truth.

The second part of this book refers to the evolution of scientific thought: *The adventure of human beings in search of positive knowledge about physical reality. The impact of scientific and mathematical thinking on rotational dynamics and its connection with concepts such as rotation, symmetry and the new algebraic mathematics.*

He therefore proposes that: *As an introduction to our study, we go and carry out a brief analysis of the evolution of scientific thought, highlighting the importance of the concept of rotation in physical knowledge and mathematical thinking.*

Human attempts to understand the world have not undergone a constant evolution; even speculation based on observation has led to conclusions which we now understand absurd and unreal but that, for reasons of authority or faith, were accepted for centuries as absolute precepts. Therefore, conclusions that today we accept as axioms, maybe considered absurd in the future. We can point out the old Latin aphorism: Quid recipitur ad modum recipientis recipitur (Whatever is received into something is received according to the condition of the receiver).

Albert Einstein and Leopold Infeld, in their book [7] The Evolution of Physics, describe the adventure of man in search of knowledge about the physical reality of our environment, highlighting the evolution of scientific thought, and especially how this evolution has been changing concepts and conclusions on many occasions during the last five hundred years. To quell its desire for knowledge, the human mind improvises conceptions of the world or adheres to systematic dogmas.

The exploration of the real world and the knowledge of physics is no example of methodical and coherent evolutionary development, but rather it seems like the zigzagging result of the timid exploration of an adaptive, intelligent being, who is subject to so many limitations and imperfections that it is hard pushed to systematically envisage a physical model, which reconciles itself with the reality in which it lives.

*The scientific observer, when faced with the complex real world constituted by the labyrinth of physical phenomena that arise when any investigation is undertaken, attempts to deduce simple laws of physical behavior that in many cases are derived from pure speculation, but which have been accepted as the foundation of our knowledge. Guillermo de Occam (1285-1349) argued that faith and reason be dissociated. He promoted a new way of understanding science by proposing that the best hypothesis is the one that makes use of fewer postulates. The so-called Occam Principle, that of parsimony (in the sense of moderation) or economy, states that “on equal terms (*ceteris paribus*), between two theories or explanations, the simpler of the two should be preferred.*

But, according to the author, the evolution of mathematical thinking is also the subject of concern: *Within scientific thought, mathematics demands special consideration as a necessary instrument of all sciences. The evolution of mathematical thinking and its implications for other sciences was clearly described by William Hamilton in 1827 in his study presented to the Royal Irish Academy, in which he expounded his new optical theory entitled A Theory of Ray Systems.*

“... Every geometric problem can be at least algebraically expressed, if not solved, and any refinement or discovery in algebra becomes susceptible to geometric application or interpretation. The sciences of space and time (adopting here a concept of algebra that I have ventured to propose elsewhere) are intimately interwoven and inextricably interrelated. Hence it is almost impossible to perfect one of these sciences without perfecting the other as well” [8].

In the text of “The Flight of the Boomerang”, Dr. Barceló adds: *The result of this process is that mathematics is not only an abstract form of expression, the result of logical deduction, but has in turn allowed us to deduce physical laws implicit in mathematical formulations. (...)*

Mathematics seeks structures and guidelines that allow us to explain in an orderly and simple way our universe, giving it order and simplicity. At present, part of the development of scientific thought, especially in modern physics, is based precisely on abstract mathematical models. It is from them that physical meaning is sought and from which structures, particles or properties which still have not been experimentally proven can be inferred [9].

In order to understand, model and explain a physical phenomenon, the scientific approach has established a precise methodology. This methodology consists of describing the phenomenon using physical laws. Also translating these laws into mathematical equations and, if the latter formulations include differential equations, obtaining the solution by means of integration or numerically, in an approximate way.

But in addition to the mathematical procedure, it is essential to be aware of both the physical nature of the magnitudes incorporated in the mathematical formulations and the system of representation of these magnitudes. In “The Flight of the Boomerang”, Dr. Barceló explains that: *For example, dynamics has seen the spread of the application of vectors for representing rotational magnitudes. The structure of vectors is useful for unifying and simplifying the manipulation of physical models. It is necessary to know the intrinsic and algebraic properties of vectors, as well as their differential features, it being a necessary condition that the magnitude represented corresponds to that vector algebra.*

... but in this vision of physics we can consider whether the mathematical formalism that is assigned to the government of nature is complete, or even if it is adequate enough in all fields of mechanics. This doubt could be satisfied by demonstrating that this formalism was sufficiently confirmed by experimental evidence, since this condition of conforming to experiments is necessary in a natural science. Part of our study focuses on this analysis in the field of rotational dynamics.

We begin our text with the study of historical antecedents, analyzing the different mathematical investigations carried out in order to represent rotations in space, even remembering Hamilton’s quaternions or Clifford’s algebra, developed as a mathematical reflection of the philosophy of J. Berkley.

For all these reasons, we would like to reiterate that the natural characteristic which, for many schools, has apparently gone unnoticed: rotation is a reality in the universe in which we reside. Even this physical reality has been by-passed for centuries in the conception of the universe [10].

4. Rotation

The author analyzes the concept of rotation in mathematics: *Rotation is analyzed in different fields of mathematics. One field of great interest is its representation in space, which also emphasizes its close relationship with the concept of symmetry. Complex algebraic methods can be applied starting from notions of rotation and symmetry, as will be discussed later. We need to be aware that even a simple comparison of measurements by two observers may entail a transposition that incorporates a translation and a rotation.*

The general laws of transformations of space and time demand a knowledge of operations of translation and rotation. The condition that these operations are invariant by translation and by rotation is applied regardless of the coordinates of the observer or of the orientation that one has in space.

We oblige the laws of physics to fulfill this invariance, since they can not depend on the observer or his or her situation, so they have to remain valid after a translation or rotation operation. Analysis has been carried out assuming there is a physical Euclidean space similar to the one we are used to observing on a daily basis with our own senses. But these same ideas can be generalized to become translations and rotations in Minkowski’s conception of four-dimensional space-time, which would bring us closer to Einstein’s laws of space-time trans-

formation among observers of motion. Einstein's theory of restricted or special relativity states that the laws of physics are invariant only for operations of symmetry that correspond to rotations and translations in four-dimensional space-time [11].

The author analyzes the historical evolution of the mathematics applicable to rotational dynamics, suggesting that, from the eighteenth century, mathematicians have been interested in the conception of mathematical models for the representation of angular displacement and rotational movement. He expresses: *The representation of rotations on one plane started from using coordinate axes with complex numbers. Kaspar Wessel was the first to conceive a geometric interpretation of complex numbers in a work of 1787, that was divulged in 1799* [12].

But Dr. Barceló reminds us that the treatment that mathematics reserved for rotation cannot be upturned without prior analysis of dynamics. Mathematical conceptions of rotation in space cannot be confused with rotational movement in space. In physics it is necessary to take into account the real nature of phenomenon and the regularities that can be observed. This possible error has also been spelled out by Professor Barceló in his new text, **New Paradigm in Physics**:

The mathematical concept of rotation must not be mixed up with rotational dynamics, in which inertia establishes the true behavior of the mass. For example, in nature we find numerous examples of the existence of two simultaneous rotations on two different axes, without any new axis appearing on account of the coupling of the previous two. The boomerang, the spinning top and the gyroscope are all cases in point [13].

5. Symmetry

Regardless of the importance of symmetry in aesthetic perception, we can define it as *an attribute by which, if a body is subjected to a certain action, it maintains its initial identity*.

Among the different forms of symmetry possible, we can highlight one that can be verified using a geometric operation of rotation. For example, if we impose a rotating motion on a perfect sphere, around any of its axes, or even on a cylinder around its main axis, we notice that the body changes its angular position, but retains the same shape or appearance, remaining unchanged, which is a manifestation of its specific symmetry. These are precisely the operations referred to in symmetry.

*Throughout the twentieth century, mathematical symmetry has been one of the most frequently used instruments in the evolution of physical science. However, a precedent of the mathematical theory of symmetry appears in the underlying rationale of the mechanics carried out by Leibniz in the eighteenth century. In its axioms, we find concepts that we can now recognize as principles of symmetry: from the symmetry of space-time homogeneity-based on the metaphysical principle of sufficient reason—, conservation laws such as that of living forces (*vis viva*)—to avoid the existence of perpetual mobility-, the variational principle*

of minimal action which preceded the work of Maupertuis and Euler, etc.

The emergence of the mathematical concept of symmetry, which implicitly incorporates the operation of rotation, driving physics by providing new speculative criteria. Abstractions that relate to the symmetries of nature associated with space and time, space-time symmetries, which imply a set of symmetries that are not present when space and time are considered in disaggregated form. For example, the invariant of the speed of light is a sign of a symmetry of nature, which connects space and time.

Emmy Noether (1882-1935) showed that the concept of the group is implicit in the laws of nature. From there, other laws as fundamental as those on conservation can be inferred. It was precisely Noether who in 1918 showed that there is a relation between continuous symmetries, invariance of mathematical formulations and laws of conservation of some basic magnitudes. Continuous symmetries are those resulting from operations with no restriction on magnitude that remain permanent although some variable might change its parameters. For example, in any rotation of a disc on a vertical axis, its contours would be conserved within the same limits, determining a continuous symmetry. The symmetry of content derived from angularly displacing the disk is continuous, since it remains constant in any other transformation, such as a translation to another place. Noether demonstrated that the law on the conservation of energy is a consequence of the continuous symmetry of delaying or bringing forward, in time, everything that happens in the universe.

From this, it has been understood that there exists a principle of symmetry implicit in the laws of nature, this principle serving as a fertile source from which to obtain specific results, since it can be formulated mathematically. This principle can also be used to infer the very same laws of evolution. By adding to this methodology the so-called Curie principle, according to which the symmetry of the effect cannot be less than that of the cause that produces it, the results obtained in the last century were fascinating. By justifying a natural phenomenon with an alleged physical law, this principle of Curie allows us to infer the characteristics of this physical law from the possible symmetries observed in experimental results, imposing certain restrictions on them.

It is precisely in mechanics where this theory is most applicable, since the possibility of establishing dynamic laws is related to the irrelevance of the place of experimentation and of the moment. In all space-time translation there is an implicit symmetry, which is why E. P. Wigner proposed that symmetry itself should be considered as the first law of invariance in physics [14].

6. Nature in Rotation

The author emphasizes the importance of movements of rotation in the universe, suggesting that there should be a correlation between these rotational movements and the physical and mathematical models that should be used in dynamics, as well as the possible relation between determinism, chaotic movement and the suitability of the proposed laws. Thus, he proposes: *In the physical*

world in which we live, everything rotates, although to an unnoticed observer it seems simply that something moves up there in the sky. The reality is that we are in a physical world based on the intrinsic movement on axes of symmetry.

The planets and their satellites rotate on their axis and orbit, but so do planetary systems and galaxies. In the first atomic models, a rotation on its axis was also attributed to the electron, at the same time as an orbit; for its part, science assigns an angular momentum, or magnitude of rotation on their axes, to atoms or atomic molecules. The fact surprises us that, in a universe characterized by its behavior in accordance with rotational dynamics, human scientific thought has mainly developed a translational dynamics which does not always apply to bodies endowed with angular momentum.

The analysis of the behavior of solids with intrinsic rotation allows us to understand some more of the causes of this presumptive scenario in which we find ourselves, constituted as it is by bodies in constant rotation, orbit and precession, although in our daily perception it seems that we exist in a flat scenario, located on the terrestrial surface and subjected exclusively to a translational index of dynamics [15].

7. Aporia of Orbitation and Precession

After these introductory themes, Dr. Barceló raises an aporia: *Curious is the fact that in nature, we usually encounter simultaneous movements of intrinsic rotation, orbitation and precession, and yet there is no mathematical model that establishes a scientific correlation for these movements when they act simultaneously. Nor do we know any kind of joint analysis that determines possible inferences of one phenomenon over the other. Following this line of reasoning, it is possible to emphasize the existence of a constant coincidence in atomic physics regarding the simultaneity of orbit and spin.*

There is no need for the existence of a mathematical correlation relating the laws of mechanics to simultaneous movements that rotate and orbit, but intuitively the aporia can be proposed that there may be a physical relationship between both movements, whose mathematical expression has not yet been proposed.

One might also wonder whether the laws currently known about the behavior of bodies in space are sufficiently exhaustive or whether, on the contrary, they do not accurately describe all possible assumptions of the true physical reality of the world around us. It is not reassuring to note that current mathematical formulas to determine the trajectory of a body in space only allow particular solutions, for specific cases, which are few in number, as the latter formulas are not able to calculate any trajectory in space when a mobile object is subjected to multiple forces and pairs of simultaneous forces.

Here, the author adds a new doubt to his analysis: *It is therefore difficult to admit that nature can behave according to an unsolvable mathematical formulation, as happens in both the determination of trajectories and in the case of n -bodies in space. Could it not be that these formulations, which science as we*

currently know it assigns to these trajectories are not the ideal ones? Could it not be that our present equations in the field of rotational dynamics are not applicable to these generalized assumptions, and that there are other unspecified mathematical laws still to be solved? On the other hand, when analyzing formal processes of computation in dynamics, we notice repeated simplifications, many of which may not be admissible in a rigorous interpretation of physics.

In this area a logical speculative difficulty may arise, many questions and qualifications arise which, in our opinion, require deeper reflection. For example, the validity and appropriateness of simplifications and the mathematical procedure used in solving equations of rotational dynamics in the different formulations used, and even if they reflect, in all cases, the true behavior of matter [16].

8. Paradox

In his book, Professor Barceló proposes that: *The approach of traditional mechanics to bodies endowed with angular momentum may seem strange. As a result of our investigative observation of nature, we can confirm that bodies that rotate around a main axis behave differently to those that move in straight lines.*

Man, fascinated by the unique behavior of bodies in rotation, gradually turned many intrinsically rotational phenomena into games and amusements, such as the spinning top, the hoop, stones skimming on the water, etc., and tried to justify their behavior based on the principle of the conservation of angular momentum or the effects of Coriolis, Magnus, geostrophic effects or others. Obviously, this typology was also analyzed at the scientific level, especially through the spinning top or the gyroscope. For Professor Miguel Catalán, in the 1950s, the behavior of the gyroscope was still a source of scientific concern. I would like to outline the work of my Professor, whose memory the International Astronomical Union wanted to perpetuate by naming one of the craters on the dark side of the Moon after: the one located 43.7°S and 85.3°W, about 25 km in diameter. In this way, the scientific community wanted to emphasize the knowledge of atoms provided by Miguel Catalán through their spectra, and especially from the iron atom.

*However, until that time only the existence of a phenomenon, which G. Bruhat set out in his book *Mécanique* and defined as a gyroscopic effect [17], was paradoxical in appearance. This implausible consideration with respect to the behavior of bodies endowed with angular momentum is commonplace in classical treatises on mechanics. If we briefly analyze the concept of rotation in the evolution of the theory of classical mechanics, we always notice a certain implausibility when dealing with this question. For example, in the *Traité de Mécanique Rationnelle* de Paul Appell, on referring to rotating bodies, he also frequently insisted on their paradoxical behavior [18].*

Obviously, a paradox is an unfortunate expression to use when defining a scientifically observed and confirmed phenomenon but it reports the behavior as, at the least, absurd or unexpected. Therefore, as the author states: ...nowadays textbooks and treatises on mechanics have given up the paradoxical approach,

avoiding this adjective when referring to rotating bodies. *For Feynman the gyroscope is a wonderful thing, but it is not a miracle. this is how he expresses it in his physics text: These are the more complicated details, but we bring them in because we do not want the reader to get the idea that the gyroscope is an absolute miracle [19].*

For A. P. French: Everybody is intrigued by gyroscopic devices, and probably everybody feels that their behavior somehow flies in the face of the usual rules of mechanics, even though intellectually one knows that cannot be the case. It cannot be denied, however, that gyroscopic movements are often seen as surprising and rare and this, of course, is the main reason for their fascination [20].

9. Historical Analysis

In this second part, the flight of the boomerang sets forth the main historical references to facts related to the concept of rotation. It analyzes the historical evolution of the concepts of circular motion and rotation, inertia, mass and its mathematical modeling, as well as subsequent experimental investigations. We incorporate into this text some of the figures that Dr. Barceló reproduces in his book, and which are examples of instruments of the 19th century (**Figures 2-7**).

The author recalls that Auguste Comte (1798-1857), was the creator of the positivist vision, which introduced science to the paradigm of rationality, and which expressed: *...you cannot really know a science without having studied its history.*

9.1. Inertia and Movement

The historical evolution of the notions of motion, inertia and mass, allows us to appreciate the slow development of the concept of inertia, which was originally

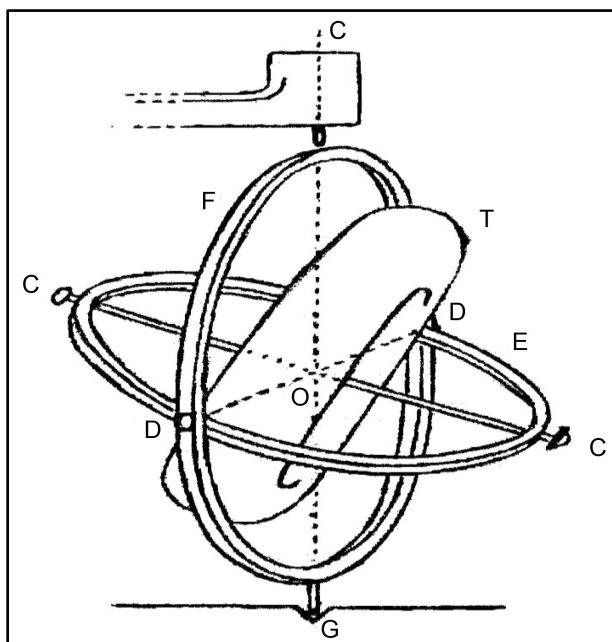

Figure 2. Bohnenberger's Machine [21].

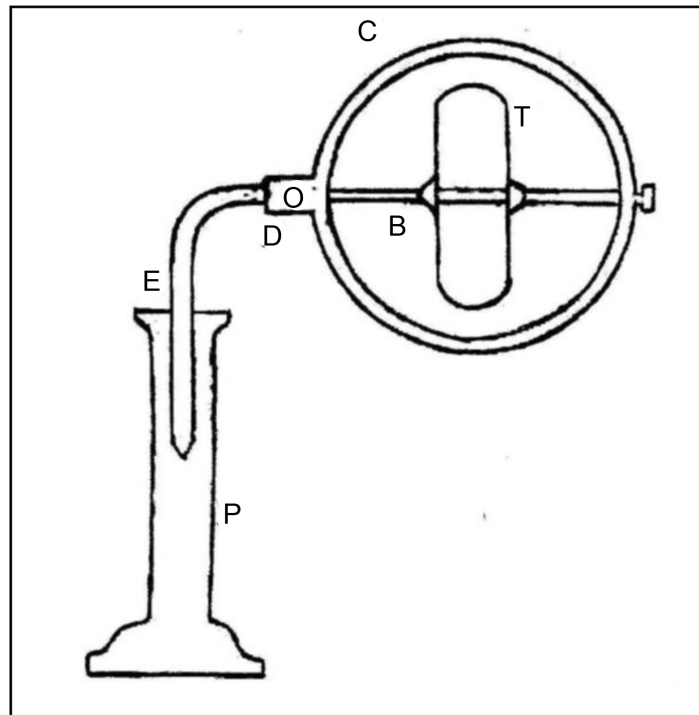

Figure 3. Fessel's spinning top [24].

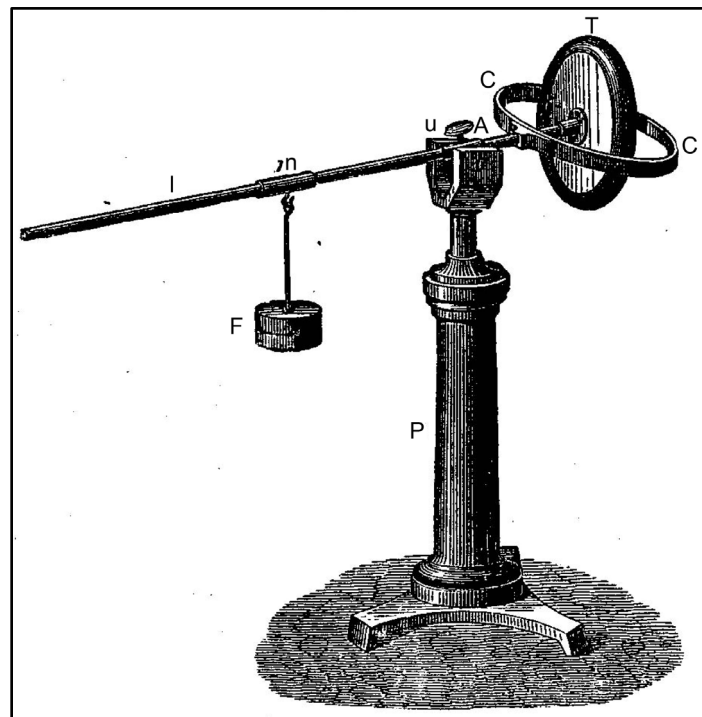

Figure 4. Plücker's Scale [25].

conceived exclusively for translational movements. Dr. Barceló also highlights in this part of his work paradigmatic examples that have been repeatedly used in history, not always with equal fortune or argumentative intention.

In his book, the author sets out his thoughts on the perception of the pheno-

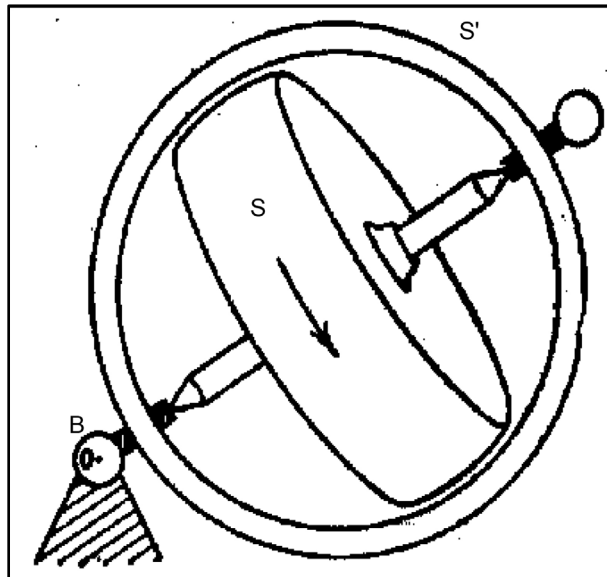

Figure 5. A representation of a simple gyroscope from G. Bruhat's Treaty of Mechanics [30].

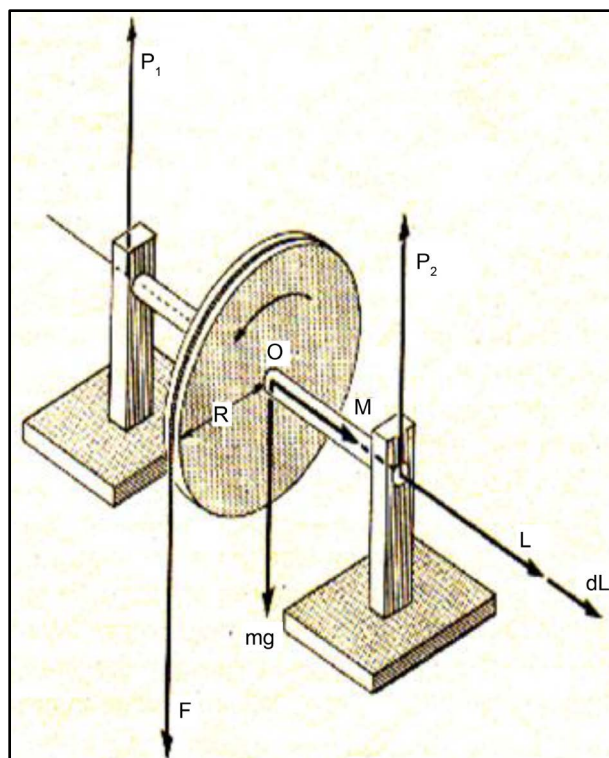

Figure 6. Behavior of the gyroscope according to Sears and Zemansky [32].

menon of inertia: *The study of the evolution of human thought on trying to define the concepts of inertia and rotation in the history of mechanics, is suggestive and allows us to understand how scientific thinking related to rotational movement was evolving.*

He further adds: *The inertia of a rotating body that rotates around an axis of*

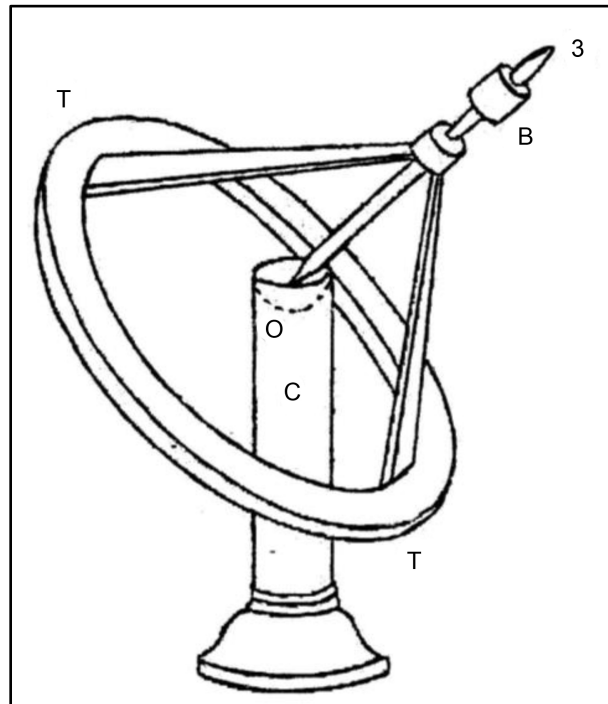

Figure 7. Robert's apparatus [33].

symmetry is, most likely, the best exponent of the Principle of Inertia, even though there have been quite a few authors, even contemporary ones, who have failed to properly understand this concept, and deny its possible application to rotating bodies. We can recall the treatise of A. Koyre, Galilean Studies, for which the law of inertia “merely states that a body abandoned to itself persists in its state of immobility or movement until something modifies that state”, adding further on that “the principle of inertia does not affirm the eternal persistence of all movement, but only of uniform motion in a straight line. The principle of inertia is not valid for circular movement. Neither is it valid for rotation” [22]. These statements are not explained or accompanied by any justificatory argument, a fact that leaves us somewhat perplexed. This shows, in our opinion, an inadequate understating of rotation and the phenomenon of inertia which, as far as we are concerned, is a very repetitive feature of a lot of treatises on mechanics.

On the contrary, the example of the gyroscope or of the simple spinning top is enlightening: a simple initial instantaneous, or practically instantaneous, torque makes it possible that, in a normal atmosphere, the body maintains its intrinsic rotation for long enough for us to be able to play games, carry out checks and applications. Under these circumstances, the initial rotation is maintained, reducing the effect of dissipative friction forces of the air or of the point of support. On the contrary, it could be argued that these assumptions are a clear example of the principle of inertia [23].

The author also analyzes the historical evolution of the concepts of circular movement and rotation, recalling even the evolution of Newton's own scientific thinking and the contributions of other physicists who have allowed us to get to

the current structuring of rational dynamics.

9.2. Experimental Studies

The author recalls how during the nineteenth century experimental investigations were carried out on bodies in rotation, using various laboratory instruments. These empirical tests permitted the proposal of some behavioral guidelines for bodies endowed with angular momentum, and even the identification and quantification of gyroscopic torque.

He tells us about the experimental physicists who were leading these studies, saying: *Throughout the nineteenth century, a profound interest in rotational dynamics can be observed, especially through experimentation with laboratory instruments and specific scientific apparatus, and the appearance of many vocations attracted by experimentation and observation of the behavior of these new devices and laboratory instruments.*

Euler, in his Theoria motus corporum solidorum, had dealt with the problem of the spinning top [26] and Poisson in his “Mémoire sur un cas particulier du mouvement de rotation des corps solides” [27], analyzes the case raised by the Bohnenberger’s machine. However, despite all these studies, some authors considered that rotational dynamics had not been given adequate attention. Gilbert said: “It does not seem to me that even now science has afforded the effects of the accelerated rotation of a body around a free axis all the attention it deserves” [28].

Precisely the first scientific apparatus that attempts to describe these phenomena of bodies in rotation is that of Johan von Bohnenberger (1765-1831), *in which the property of an axis of rapid rotation is used to resist the action of gravity to describe astronomical phenomena [29].*

We can consider that this apparatus is the first known reference of the gyroscope, although this name was assigned later by J-B. León Foucault.

Dr. Barceló reminds us of the different devices that were designed in the nineteenth century to study the rotation of bodies, such as *Fessel’s Spinning Top*, *Plücké’s Scale*, or *Robert’s apparatus*, among others (See **Figure 3**; **Figure 4** and **Figure 7**).

However, in spite of the interest aroused among the scientists of the time, great advances were not made, keeping the knowledge at an experimental stage.

10. The Gyroscope

In this historical study, the author analyzes the different interpretations with which the treatises of classical mechanics justified the behavior of bodies endowed with angular momentum, as well as the evolution of these interpretations throughout the history of physics.

Sears and Zemansky’s explanation of this relative illustration of gyroscopic behavior generated disarray and confusion for Dr. Barceló when he was studying his engineering degree, a further indication for him of the insufficient develop-

ment of rotational dynamics at that time.

In relation to the gyroscope, he expresses in his work that: *Any apparatus that uses the properties of a solid in revolution is called a gyroscope. It will have a rotor that can rotate freely with respect to its geometric axis. It has been a laboratory instrument whose behavior has been of interest to physicists and, as a result of the experiments performed, it has been used in multiple applications* [31].

He also recalls that what has been set out in different treaties, has not always been done so correctly. After analyzing rotational dynamics and the concept of rotation in modern physics, and its historical evolution, Dr. Barceló presents a series of indications and caveats to the orthodoxy he suggests should be contrasted with observation and experimentation. In order to confirm the applicable interpretation criteria with sufficient scientific rigor.

He bases his doubts on the fact that structures for rotational dynamics have their foundations in what is translational, when the existence of rotations determines a specific differentiation, since these rotations necessarily generate acceleration, and therefore, we find ourselves with non-inertial systems.

At this stage of his research, the author intuits the existence of a possible conceptual confusion, when axioms of the dynamics of inertial systems are applied, to non-inertial movements that are due to acceleration because of rotation.

11. Formulations of Dynamics

After the historical study of rotational dynamics, the author analyzes the fundamentals of rational mechanics and their different dynamic formulations, applied mathematical procedures and their interpretations in rotational dynamics, exposing an acute criticism, suggesting caveats or doubts about classical scientific argumentation.

He analyzes the fundamentals of rational mechanics and their different formulations, suggesting possible interpretive errors in the field of this dynamics, which are due to the fact that scientists do not take into account the fact that rotational dynamics is a part of non-inertial physics, since these acceleration coexist in the same.

Dr. Barcelo says: *Classical or rational mechanics is constructed as a logical necessity to relate the interactions generating the movement of material distributions, with the coordinates and with the components of velocity and acceleration. In short, with the kinematics of the same. It is characterized by the fact that the minimum material particle does not have a certain value, that is, it is infinitesimal. A particle occupies a point-moment of space-time. Depending on the existing interactions, their nature and intensity, it will be possible to describe the space-time evolution of each particle.*

For Paul Appell, mechanics is a mathematical science that analyzes the physical causes of movement but with the caveat that “it is impossible to discover the true causes of physical phenomena, and we are content to replace the real causes, which produce phenomena, with other fictional causes called forces, capable of producing the same effects” [34].

12. Dynamic Interactions

In the last part of his treatise, Dr. Barceló, in response to his conceptual disagreement, suggests the idea of an imaginary nature, in which certain abstractions adopt expressions different from those accepted in orthodoxy, proposing an alternative mathematical physical model to classical rotational dynamics.

It is a subtle way of introducing into the text the new dynamic hypotheses of non-inertial systems that have arrived after observation, deduction, and inference. He also proposes to apply this model to the explanation of movements hitherto interpreted as chaotic or indeterminate, even to understand other phenomena and behaviors, such as the flight of the boomerang.

After experimentation and observation, the author incorporates a new concept, that of *Dynamic Interaction*, defining it as: *The reciprocal action of bodies in motion and the resultant effect due to the dynamic and inertial reactions of the mass.*

And he proposes that *Dynamic interactions* are reactions generated in bodies endowed with intrinsic angular momentum, when they are subjected to new non-coaxial momenta. They are spontaneous reactions that *occur in systems in free rotation in space, when they are provoked by stimuli that produce a characteristic and distinguishing behavior, with respect to bodies without intrinsic rotation.*

In the text, the author states that: *There are enough indications to excite our curiosity and to suppose that, in certain cases, bodies with intrinsic rotation, subjected to successive non-coaxial forces torques, describe trajectories that cannot be justified by the laws hitherto recognized by classical mechanics. At this point we might wonder whether such unpredictable movements are now indeterminate and chaotic, or are simply governed by other unknown laws of behavior.*

But it was evident that the laws relating to the dynamic behavior of bodies with angular momentum, subject to successive torques, had to be obtained after the observation of these bodies in space and the analysis of their trajectories. After deductions and previous experiments, we came to the conclusion that a dynamic model could be inferred in which rotational inertia was an inherent property of mass. An attribute that remains constant and that determines, when there is an intrinsic rotation movement, its impossible vector composition with other rotational movements.

We understand that the design of a rotational dynamics of dynamic interactions based on a physico-mathematical model coherent with these premises and conceptually differentiated from orthodoxy can be considered, due to a simple reinterpretation of the dynamic behavior of matter [35].

13. Configuration of the Model

The author wants to introduce his new physical paradigm without creating aversion or rejection, so he proposes: *In the case that the dynamic interactions model could be applied to certain dynamic behaviors in space, when a revolving body is*

subjected to successive moments of non-coaxial forces, in addition to having to develop deductive behavior laws from this alternative model, we might ask if this model and its laws of development are complemented by the accepted structure for the current and orthodox rational mechanics or if, on the contrary, it implies a substantial modification of that structure.

However, the proposed thesis may imply a structural modification of mechanics, since in today's physics a correlation between symmetry and conservation of magnitudes is assumed from E. Noether.

But this correlation, according to group theory, is based on a bi-univocal relationship between associated symmetry and dynamic typology. In this way there is a clearly differentiated duality, admitting:

- *Translational symmetry and translational Lagrangian formalism.*
- *Rotation symmetry and Lagrangian rotation formalism.*

But in the current orthodox theoretical model, a symmetry of the simultaneous coupling of translation + rotation with a specific Lagrangian or Hamiltonian formulation is not recognized. For its incorporation into the structure of rational mechanics, the proposed mathematical model would require a new concept of non-discriminant dynamic coupling, and a new Lagrangian, or Hamiltonian, formulation incorporating this coupling, at least in those cases in which successive non-coaxial rotations are generated, simultaneously with translations.

Only through experimentation could we identify the possible suitability of this model to represent the true behavior of bodies in certain dynamic assumptions, with non-coaxial translation and successive rotations [36].

14. Epilogue

The author ends his text with an epilogue, summarizing the dynamic proposals that he has been presenting. Remember that this book supposes ...*the renewal of an old forgotten debate, but that could still be current. the concept of rotation in dynamics, an analysis of the behavior of bodies with angular momentum and their mathematical treatment.*

He recalls below how The historical evolution of scientific thought has given us mathematical models applicable to mechanics, with apparent proven technological results. In particular, analytical mechanics offers us a valuable methodology of analysis and abstract verification, which admits adaptations and generalizations to focus on fields of study other than dynamics itself.

For example, the Lagrangian formulation allows transparent treatment of the symmetries of physical systems and their consequences in the dynamic evolution of the same.

The Noether theorem, which establishes the relationship between symmetries of the configuration of the system and the physical magnitudes preserved, allows one to analyze the dynamic ruptures in the symmetries. When rotational symmetry is eliminated by the presence of a torque, then, in accordance with orthodox rational mechanics, it is estimated that the angular momentum temporarily evolves according to Euler's equations. In the case of systems which are invariant

to rotations of spatial coordinates, we verify that, the conservation of angular momentum is associated to this invariance. Thus we have a dynamic theory and a mathematical model, with different formulations and equivalent results [37].

Dr. Barceló then poses a series of questions about the current structure of this area of knowledge, and the possible indications that allow us to conceive of alternative solutions.

There is also a clear coherence between the representation of rotations in space and group theory, and we have seen how spatial rotations are classified as members of the Lie $SO(3)$ group and it has been determined that it is a compact double-connected group. Can we permit the raising of any doubt about this mathematical structure? Is it really a closed, ideal and complete methodological structure? Are there any indications that allow us to question classical rotational dynamics?

We have proposed a historical analysis and an objective analysis of the accepted theories about the existence in rotational dynamics of certain phenomena traditionally called paradoxical, singular effects, dynamic questions pending resolution and multiple examples that could question this orthodoxy. Would it be possible to have forgotten the natural tendency in the historical evolution of rotational dynamics in the face of the great scientific events of the early twentieth century?

After raising these questions, he concludes that there may be a different and alternative conceptual mathematical model for rotational dynamics: *Based on certain dynamic conjectures and based on a reinterpretation of the behavior of bodies endowed with intrinsic angular momentum when subjected to successive torques, according to the hypotheses proposed, we conclude that an alternative mathematical model can be conceived in rotational dynamics. With this model, different results are obtained for certain cases, based exclusively on reinterpreting the composition or overlap of movements due to the forces acting upon them [38].*

In this new model that he conceives, he does not accept the unjustified discrimination that current rotational dynamics exercises on not permitting that movements generated by forces couple with those resulting from torques: *Nor is the discrimination established by Poinsot and accepted as a tacit axiom accepted in our alternative model, by which there is in nature a possible coupling of the resulting actions between forces and pairs, incorporating the concept of rotational inertia and admitting inertial behavior, which is differentiated and peculiar to matter. We cannot accept that rotational dynamics is based on the simple geometric expression of rotations, although mathematically it is correct, since in dynamics one must also take into account the inertial behavior of matter.*

As a summary, and in response to the initial aporia of rotation and orbiting, Dr. Barceló suggests that this orbiting movement does not have to be generated by a central force: *As a synthesis of the proposed theory in accordance with the alternative mathematical model, we conclude that the orbiting movement of a body in space, endowed with intrinsic rotation, is not necessarily due to a central*

force. Orbiting may be the dynamic result of the inertial interaction of a non-coaxial pair with the angular momentum of the body. In this case, the external action is torque and, although the resulting force on the center of the mass of the body is zero, a dynamic coupling would occur between the actuating torque and the linear kinetic moment of the body, resulting in a modification of the trajectory of the center of mass without the need, we insist, for an external force to act upon it.

By means of this model of dynamic interactions that is sustained, it could be justified how a body endowed with angular momentum, can initiate an elliptical, circular or even helical trajectory without the existence of a true central force. According to this dynamic model, the application of a pair of forces to a body with intrinsic rotation, generates a stable system, which is also in a constant dynamic equilibrium [39].

He justifies his argument with the experimental tests carried out by Advanced Dynamics, and even by other external researchers, and with the conceived simulation model: *The results of the simulation of this model were represented by a computer program, showing how, while keeping the torque constant, the mobile object, according to this alternative model, describes a closed and immutable orbit, located on a plane determined by the acting pair and the vector of the translation velocity of its center of mass. Does this model not coincide with multiple examples in astrophysics?*

We have also warned through simulation that a trajectory can be modified by varying the translation velocity or the active pair, obtaining different traces that could prove interesting. For example, a helical path is obtained when the translation velocity is variable. Could this trace be applied to the dynamics of the galaxies or to the Saturn's rings? [40]

Finally, he proposes to investigate and persevere in these studies, developing new mathematical-fiscal models in rotational dynamics, until obtaining their quantitative and experimental verification: *Therefore, we suggest that this alternative mathematical model should be investigated, especially in cases that generate successive or simultaneous non-coaxial rotations, estimating the possible application of these hypotheses to astrophysics and in general to the dynamics of bodies with angular momentum, to confirm the proposed thesis: the existence of a mathematical correlation between orbit and intrinsic rotation. We suggest that this model, even in its simplified form, would be able to reconcile many dynamic problems that are still unclear or unresolved. This proposal, in the purely formal sphere, is based on Fermat's criterion of economy or Occam's Principle of Knowledge, its mathematical formulation is clearly simpler, and easily solved.*

The quantitative and experimental verification of these hypotheses could favor new advances in the discovery of the apparently disconcerting behaviors of certain dynamical systems or even could be applicable to other disciplines such as geophysics, quantum mechanics or electromagnetism. The technological applications of this alternative mathematical model would also be ample and suggestive, especially in the sphere of ballistics, space transport or the control and go-

vernance of probes, satellites, ships or projectiles equipped with angular momentum. In all these fields, safer and more accurate navigation and steering systems could be designed to reduce the cost of operation.

There is still a vast field of research and testing in science and technology in this area and it would not always be necessary to invest in such experimentation. In addition to a specific experimental project, mathematical development would be necessary to determine new Lagrangian or Hamiltonian formulations, consistent with this model. The analysis of these new scientific objectives would be the result of vocation and inquisitive thought.

The development of alternative models of rotational dynamics, their experimental contrasting and the determination of limits and conditions of action, would possibly open new horizons to physics and to new unimagined scientific and technological developments [41].

Dr. Barceló himself has responded by answering the questions he posed in this treaty, and specifically in this epilogue, in books and in later documents. He has built a true scientific theory of rotation, totally different from what is now considered as orthodox. He has formulated a rotational dynamics of dynamic interactions, based on a physico-mathematical model consistent with these premises, and conceptually differentiated from existing orthodoxy, due to a simple reinterpretation of the dynamic behavior of matter.

References

- [1] Barceló, G. (2006) The Flight of the Boomerang. (El vuelo del bumerán.), Marcombo, Barcelona, 21. <http://www.dinamicafundacion.com/>
- [2] Barceló, G. (2006) The Flight of the Boomerang. (El vuelo del bumerán.), Marcombo, Barcelona, 340. <http://www.dinamicafundacion.com/>
- [3] Barceló, G. (2006) Theory of Dynamic Interactions: The Flight of the Boomerang. *Journal of Applied Mathematics and Physics*, **2**, 569-580. <http://www.scirp.org/journal/jamp>
- [4] Barceló, G. (2015) Theory of Dynamic Interactions: The Flight of the Boomerang II. *Journal of Applied Mathematics and Physics*, **3**, 545-555. <http://www.scirp.org/journal/jamp>
<https://doi.org/10.4236/jamp.2015.35067>
- [5] Sanchez Boyer, J. (2015) The Flight of the Boomerang II. Video. https://www.dropbox.com/s/stng5b2co1441hk/Boomerang_ENG_mini.mp4?dl=0
<https://www.youtube.com/watch?v=mGfrGW5fhOg&feature=youtu.be>
<https://vimeo.com/129383447>
- [6] Barceló, G. (2006) The Flight of the Boomerang. (El vuelo del bumerán.), ep. 9.1, Marcombo, Barcelona, 197. <http://www.dinamicafundacion.com/>
- [7] Albert, E. and Leopold, I. (1995) The Evolution of Physics. Salvat Science.
- [8] William, H. (1827) A Theory of Ray Systems. Transactions of the Royal Irish Academy, Vol. 23, Royal Irish Academy, Dublin.
- [9] Barceló, G. (2006) The Flight of the Boomerang. (El vuelo del bumerán.), ep. 2.2, Marcombo, Barcelona, 31. <http://www.dinamicafundacion.com/>
- [10] Barceló, G. (2006) The Flight of the Boomerang. (El vuelo del bumerán.), ep.2.2, Marcombo, Barcelona, 32. <http://www.dinamicafundacion.com/>

- [11] Barceló, G. (2006) The Flight of the Boomerang. (El vuelo del bumerán.), ep. 2.3, Marcombo, Barcelona, 34. <http://www.dinamicafundacion.com/>
- [12] Barceló, G. (2006) The Flight of the Boomerang. (El vuelo del bumerán.), Marcombo, Barcelona, 123. <http://www.dinamicafundacion.com/>
- [13] Barceló, G. (2017) New Paradigm in Physics, Volume I: Theory of Dynamics Interactions. Section 2.2.7, 134.
- [14] Barceló, G. (2006) The Flight of the Boomerang. (El vuelo del bumerán.), ep. 2.4, Marcombo, Barcelona, 37. <http://www.dinamicafundacion.com/>
- [15] Barceló, G. (2006) The Flight of the Boomerang. (El vuelo del bumerán.), ep. 3.1, Marcombo, Barcelona, 41. <http://www.dinamicafundacion.com/>
- [16] Barceló, G. (2006) The Flight of the Boomerang. (El vuelo del bumerán.), ep. 3.3, Marcombo, Barcelona, 46. <http://www.dinamicafundacion.com/>
- [17] Bruhat, G. (1955) Mécanique. Masson & Cie, Paris.
- [18] Appell, P. (1909) Traité de Mécanique Rationnelle. Gauthier-Villars, Paris, 325.
- [19] Feynman, Leighton and Sands (1963) Lectures on Physics. Addison-Wesley Iberoamerican Publishers, Technical Institute of California, 11-20.
- [20] French, A.P. (1971) Newtonian Mechanics. The M.I.T. Introductory Physics Series, W. W. Norton & Company, New York, 717.
- [21] Bohnenberger, J. (1817) Tübinger Blätterfür Naturwissenschaft und Arzneykunde, t-III. 31.
- [22] Koyre, A. (1978) Galilean Studies. Hermann, Paris.
- [23] Barceló, G. (2006) The Flight of the Boomerang. (El vuelodel bumerán.), ep. 4.1, Marcombo, Barcelona, 58.
- [24] Gilbert, P. (1878) Étudehistorique et critique sur le problème de la rotation d'un corps solide autour d'unpoint. Brusels, 27.
- [25] Gilbert, P. (1878) Étudehistorique et critique sur le problème de la rotation d'un corps solide autour d'un point. Brusels.
- [26] Euler, L. (1763) Theoria Motus Corporum Solidorum. Rostock, 377-538.
- [27] Poisson, S.D. (1820) Mémoire sur uncasparticulier du mouvement de rotation des corps solides. *Journal de l'Ecolepolytechnique*, **16**, 247.
- [28] Gilbert, P. (1876) Problème de la rotación d'un corps solide autour d'unpointfixe. Annales de la Société Scientifique de Bruxelles, 296.
- [29] Bohnenberger, J. (1817) Tübinger Blätterfür Naturwissenschaft und Arzneykunde, t-III. 45.
- [30] Bruhat, G. (1955) Treaty of Mechanics. Masson & Cie, Paris.
- [31] Barceló, G. (2006) The Flight of the Boomerang. (El vuelo del bumerán.), ep. 10.1, Marcombo, Barcelona, 215.
- [32] Sears and Zemansky (1957 & 1981) Física General. Madrid.
- [33] Gilbert, P. (1878) Étudehistorique et critique sur le problème de la rotation d'un corps solide autour d'un point. Brusels, 29.
- [34] Appell, P. (1909) Traité de Mécanique Rationnelle. Villars, Paris, 5.
- [35] Barceló, G. (2006) The Flight of the Boomerang. (El vuelo del bumerán.), ep. 12.1, Marcombo, Barcelona, 279.
- [36] Barceló, G. (2006) The Flight of the Boomerang. (El vuelo del bumerán.), ep. 12.9., Marcombo, Barcelona, 307.
- [37] Barceló, G. (2006) The Flight of the Boomerang. (El vuelo del bumerán.), Epilogue,

- Marcombo, Barcelona, 308.
- [38] Barceló, G. (2006) The Flight of the Boomerang. (El vuelo del bumerán.), Epilogue, Marcombo, Barcelona, 309.
- [39] Barceló, G. (2006) The Flight of the Boomerang. (El vuelo del bumerán.), Epilogue, Marcombo, Barcelona, 310.
- [40] Barceló, G. (2006) The Flight of the Boomerang. (El vuelo del bumerán.), Epilogue, Marcombo, Barcelona, 311.
- [41] Barceló, G. (2006) The Flight of the Boomerang. (El vuelo del bumerán.), Epilogue, Marcombo, Barcelona, 312.



Scientific Research Publishing

Submit or recommend next manuscript to SCIRP and we will provide best service for you:

Accepting pre-submission inquiries through Email, Facebook, LinkedIn, Twitter, etc.

A wide selection of journals (inclusive of 9 subjects, more than 200 journals)

Providing 24-hour high-quality service

User-friendly online submission system

Fair and swift peer-review system

Efficient typesetting and proofreading procedure

Display of the result of downloads and visits, as well as the number of cited articles

Maximum dissemination of your research work

Submit your manuscript at: <http://papersubmission.scirp.org/>

Or contact wjm@scirp.org