



AUSTRALIAN ATOMIC ENERGY COMMISSION  
RESEARCH ESTABLISHMENT  
LUCAS HEIGHTS

MEASUREMENT AND REDUCTION OF FLOW-INDUCED VIBRATION  
OF A FUEL ELEMENT AND RIG IN THE HIFAR REACTOR

by

R. W. HARRIS  
P. G. HOLLAND

May 1975

ISBN 0 642 99685 7

AUSTRALIAN ATOMIC ENERGY COMMISSION  
RESEARCH ESTABLISHMENT  
LUCAS HEIGHTS

MEASUREMENT AND REDUCTION OF FLOW-INDUCED VIBRATION  
OF A FUEL ELEMENT AND RIG IN THE HIFAR REACTOR

by

R.W. HARRIS  
P.G. HOLLAND

ABSTRACT

Flow-induced vibrations in the fuel element assembly of a research reactor were monitored and it was established that long-term monitoring of liner plug vibration can be used to indicate the mechanical integrity of a fuel element if a sufficient case history is established.

The vibrational behaviour of a number of fuel elements with different integral modifications was examined but only a relatively small change in vibration levels was obtained. The overall vibration levels were most effectively decreased by installing flow straighteners in the exit nozzles of the plenum chamber.

## CONTENTS

	Page
1. INTRODUCTION	1
2. IN-PILE MONITORING	1
2.1 Vibration Monitoring at Shield Plugs	1
2.2 In-pile Measurements of Liner Vibration	2
2.3 Initial Results from Shield Plug and Liner Measurements	2
3. INVESTIGATION OF INTEGRAL MODIFICATIONS TO FUEL ELEMENTS	2
3.1 In-pile Experiments	3
3.2 Out-of-pile Experiments	4
3.3 Summary of Results of In-pile and Out-of-pile Tests	4
4. INVESTIGATION OF THE EFFECT OF FLOW STRAIGHTENERS IN THE PLENUM CHAMBER EXIT NOZZLES	4
5. CONCLUSIONS	5
6. ACKNOWLEDGEMENTS	5
7. REFERENCES	5

National Library of Australia card number and ISBN 0 642 99685 7

The following descriptors have been selected from the INIS Thesaurus to describe the subject content of this report for information retrieval purposes. For further details please refer to IAEA-INIS-12 (INIS: Manual for Indexing) and IAEA-INIS-13 (INIS: Thesaurus) published in Vienna by the International Atomic Energy Agency.

CLOSURES; FLOW REGULATORS; FLUID FLOW; FUEL ELEMENTS; HIFAR REACTOR; MECHANICAL TESTS; MECHANICAL VIBRATIONS; NOZZLES

Table 1	Comparison of Accelerations and Pressure (r.m.s.) Levels
Table 2	Results of Student's t Test on Table 1 Data for Levels of Significance up to 5 per cent
Figure 1	HIFAR fuel element and liner
Figure 2	Schematic diagram of rig X-184/2 and block diagram of instrumentation
Figure 3	Mean-square accelerations for X-184 for three pump combinations
Figure 4	Mean-square accelerations for hollow fuel element shield block for three pump combinations
Figure 5	Grouped representation of average vibration level $\bar{E}$ for X-184
Figure 6	Grouped representation of average vibration level $\bar{E}$ at the HFE shield plug
Figure 7	Noise spectra of X-184 pressure transducer
Figure 8	Bar chart comparison of r.m.s. acceleration levels for the hollow fuel element shield plug before and after fitting flow straighteners
Figure 9	Bar chart comparison of r.m.s. acceleration levels in the rig before and after fitting flow straighteners

(continued)

## CONTENTS (continued)

- Figure 10 Vibration test modification 1 to HIFAR fuel element design drawing
- Figure 11 Vibration test modification 2 to HIFAR fuel element design drawing
- Figure 12 Vibration test modification 3 to HIFAR fuel element design drawing
- Figure 13 Vibration test modification 4 to fuel element design drawing.

## 1. INTRODUCTION

Flow of coolant in the channels of a nuclear reactor will always induce some vibration of the fuel elements. This flow-induced vibration in a research reactor of a type similar to the Australian Atomic Energy Commission's reactor HIFAR was of sufficient magnitude to cause mechanical damage to fuel element components (K.F.A. 1968). Recently flow-induced vibration in HIFAR caused a nose cone on the end of an irradiation rig to separate from the body of a rig (R. Hemphill, AAEC private communication). The rig as illustrated in Figure 1 is a long hollow cylinder inserted in the centre of the fuel element. This flow-induced vibration failure led to an investigation to monitor and, if possible, to locate the source of the vibration in HIFAR, and then to attempt to devise means of reducing both the magnitude of the vibration and its damaging effects.

## 2. IN-PILE MONITORING

### 2.1 Vibration Monitoring at Shield Plugs

Although it is usually impractical to mount vibration sensors within the core of a reactor, HIFAR has a well-defined mechanical path between the fuel element and the top of the fuel element shield plug (see Figure 1) so measurements of vibration at the top of a fuel element shield plug should provide information about vibration within that fuel element. In this investigation the vibration sensors used were accelerometers (Brüel and Kjaer type 4335) which were permanently attached to the fuel element shield plug using insulating studs and washers to minimise electrical pickup.

The signals from each of the 25 accelerometers, one associated with each fuel element position, were fed from the reactor top to a patch panel through co-axial cable. The patch panel allowed any of the 25 vibration signals to be monitored, initially by recording and subsequent replaying and analysis, and at a later date by using a land-line joining the reactor and the Noise Analysis Laboratory located 700 m away. Regular monitoring initially examined the rms value of the vibration signals, and subsequently the frequency domain in greater detail using a real time spectrum analyser. Some controlled experiments using dummy fuel elements (no uranium metal in the fuel element plates) showed that a frequency analysis of the vibration signals at the fuel element shield plugs would indicate the presence of loose plates in the fuel element (Harris & Winsbury 1973).

The *in situ* monitoring indicated the core positions with consistently large or erratic vibration levels. It appeared also that the vibration depended on which two of the three available main circulating pumps were employed.

### 2.2 In-pile Measurements of Liner Vibration

Figure 1 shows that the fuel element liner is unconstrained at its lower end. The freedom of movement there could cause damage to the fuel element by impacting the lower support combs, and so a complete investigation of vibration should look separately at the behaviour of the liner. To measure this behaviour, a special experimental liner was constructed incorporating vibration sensors as well as pressure sensors to monitor one of the parameters of the coolant flow.

Two versions of the experimental liner X-184/1 and X-184/2 were constructed. Rig X-184/1 consisted of a HIFAR liner with a sealed instrumentation package at its lower end, its remaining section flooded. The instrumentation package contains a pair of mutually perpendicular accelerometers to monitor vibration, and pressure transducers. X-184/1 had a single transducer at the bottom of the package with an opening to the oncoming coolant flow. The second version, Rig X-184/2, is depicted in Figure 2. X-184/2 had a pair of pressure transducers flush-mounted in the side wall of the package mutually perpendicular to one another with their axes above those of the accelerometers.

The signal leads from the transducers were passed through an aluminium tube welded to the instrument package. This tube was routed along the liner axis to a special liner shield plug where it passed to the top of the reactor via a groove milled along the outside of the plug. The signals from the transducers, including a signal from the shield plug accelerometer (Section 2.1), were suitably amplified and recorded. The signals were later analysed to obtain variances and spectra. The orientation of the rig relative to the reactor core was held constant for each investigation.

Difficulties were experienced in obtaining dynamic pressure readings in both versions of Rig X-184. The pressure transducer in Rig X-184/1 eventually failed completely because of a breakdown in lead insulation arising from the high  $\gamma$ -flux in the reactor. The Rig X-184 was used only when the reactor was shut down, but a large residual  $\gamma$ -flux still existed.

### 2.3 Initial Results from Shield Plug and Liner Measurements

The mean square acceleration for both the experimental liner and the fuel element shield plugs are given in Figures 3 and 4 respectively and Figures 5 and 6 give a pictorial representation of the same data quantised in four levels. This data will be compared with data obtained at a later date when flow straighteners were fitted in Section 4.

## 3. INVESTIGATION OF INTEGRAL MODIFICATIONS TO FUEL ELEMENTS

One way of reducing vibration levels in a fuel element assembly is by

modifying it. Modifications were made but experiments reported below showed that this approach was not effective because the main result was simply to redistribute the energy within the fuel element assembly.

The modifications were designed to change the flow structure and/or provide a more positive location of the free end of the liner.

A detailed description of the modifications examined is given in the Appendix, but some brief details are:

- . modification 1 was a four-vane flow straightener installed in the inlet section of the fuel element;
- . modification 2 was an extra truncated cone fitted inside the inlet section of the fuel element and was designed to produce hydrodynamic support at the base of the liner;
- . modification 3 was similar to 1 with a conical seat added on top of the flow straightener into which the liner locates; and
- . modification 4 was similar to 1 with a spring garter added to constrain the liner at its lower end.

### 3.1 In-pile Experiments

The in-pile experiments were performed on an unmodified fuel element, and on fuel elements with modifications 1 and 4. A further parameter investigated was the use of dimples welded on the side of X-184/2 (used as a liner) as a constraining influence on the motion of the liner.

The parameters monitored were rig vibration, coolant pressure fluctuations using the transducers in X-184, and shield plug vibration using the accelerometer on the fuel element shield plug. The experiments were carried out in positions B5 and E1 in the reactor where B5 typified a high vibration level position and E1 a low vibration level position. The experiments were also carried out for all combinations of the main circulating pumps and for dimples and no dimples on X-184/2. They are summarised in Table 1 where a large variation in the data is apparent.

The choice of pump combination had a large effect on the results, and to see whether this was predominant, a statistical test was applied to the data. The significant results are given in Table 2. Some degree of importance may be given to differences between configurations, if the level of significance is 5 per cent.

Table 2 yields the following conclusions:

- . the choice of pump combination has a major effect on the vibration levels;
- . the modifications had a significant effect for position E1 where

- modification 1 produced a *higher* vibration level at the shield plug;
- the effect of dimples on the rig for the unmodified fuel element caused an overall decrease in vibration; and
- when both reactor positions are considered modification 4 gave generally low vibration levels.

### 3.2 Out-of-pile Experiments

Measurements were made using both Rig X-184/1 and Rig X-184/2 on an out-of-pile facility which provided a total flow rate of demineralised water close to that in the HIFAR reactor. The unsteady flow conditions at the entrance to the fuel element assembly in this rig were naturally different from the actual reactor, however, the vibrations induced were comparable in magnitude with the worst positions in the reactor. The fuel element assemblies examined in the facility were an unmodified fuel element and modifications 2, 3 and 4.

Modification 2 produced no decrease in vibration levels, but greatly altered the spectrum of the pressure variations in the coolant flow. Figure 7 shows the spectrum of the pressure signals both for modification 2 and the unmodified fuel element.

Modification 3 produced higher vibration levels for the total assembly as monitored by an accelerometer on the shield plug, but both the vibration and dynamic pressure at the rig were diminished. This modification has apparently caused only a redistribution of the excitation energy entering the system via the unsteady component of the coolant flow.

Modification 4 provided only a minimal decrease in vibration levels, even when different values for diametral interference between the rig and spring garter were considered.

### 3.3 Summary of Results of In-pile and Out-of-pile Tests

In-pile and out-of-pile tests showed that integral modifications to the fuel element assembly do not produce any significant reductions in vibration levels. In several cases, a simple redistribution of energy within the assembly occurred.

## 4. INVESTIGATION OF THE EFFECT OF FLOW STRAIGHTENERS IN THE PLENUM CHAMBER EXIT NOZZLES

Since the above experiments provided no significant reduction in vibration levels, the Reactor Operations Group decided to follow overseas practice in fitting flow straighteners in the exit nozzles of the plenum chamber on which the fuel elements sit. These flow straighteners should modify fluctuations in the fluid flow and any energy they dissipate should

not be returned to the fuel element assembly since they are not an integral part of this assembly.

After flow straighteners were fitted a vibration scan of the core was carried out using X-184/2. Their effectiveness in reducing vibration levels is conclusively demonstrated in a comparison of the results of this scan with earlier measurements when no flow straighteners were fitted (Figures 8 & 9).

## 5. CONCLUSIONS

- Long-term monitoring of the vibration level at a shield plug can provide information about the mechanical integrity of a fuel element provided a case history has been established.
- Integral modifications to the fuel element assembly produced only marginal decreases in vibration levels, while other effects, such as the combination of main circulating pumps employed, produced larger changes in vibration levels.
- Installation of flow straighteners in the exit nozzles of the plenum chamber reduced the overall vibration levels, particularly for those reactor core positions which had previously exhibited large vibration levels.

## 6. ACKNOWLEDGEMENTS

The assistance of the HIFAR Reactor Operations Staff and of Messrs W.F. Carr and D.D. McColm who analysed the tape recordings is gratefully appreciated. The encouragement of Dr. T.J. Ledwidge is also acknowledged.

## 7. REFERENCES

- K.F.A. (1968) - Brennelementschaeden am Forschungsreaktor FRJ-2 in April/Mai, Kernforschungsanlage, Jülich, Federal Republic of Germany.
- Hemphill, R.J. - AAEC private communication
- Harris, R.W. & Winsbury, G.J. (1973) - Mechanical Integrity Monitoring of HIFAR Reactor Fuel Elements. Paper No. 622, International Symposium on Vibration Problems in Industry, Keswick, England, April.

TABLE 1  
COMPARISON OF ACCELERATIONS AND PRESSURE (rms) LEVELS

Test Condition		Root Mean Square Level of Sensor																	
Position	Pumps	Shield Plug Acceleration						Rig Acceleration						Rig Pressure					
		Fuel Element Assembly						Fuel Element Assembly						Fuel Element Assembly					
		A	B	C	A'	B'	C'	A	B	C	A'	B'	C'	A	B	C	A'	B'	C'
B5	1+2	100	40	33	74	88	51	100	98	73	81	96	124	100	220	215	491	222	261
	1+3	28	45	29	25	45	21	80	105	71	61	95	74	104	200	219	124	230	205
	2+3	25	46	26	24	47	20	100	124	82	59	94	70	105	230	222	156	230	177
E1	1+2	20	28	19	32	27	21	87	67	111	75	66	73	770	145	108	95	154	150
	1+3	24	30	28	24	29	33	92	70	66	52	69	53	106	150	115	101	160	326
	2+3	23	28	24	19	29	25	184	72	48	35	63	47	101	148	112	95	161	176
		100 $\equiv$ 0.052 $g_n$						100 $\equiv$ 0.209 $g_n$						100 $\equiv$ 1.04 kPa					

Legend: (Dummy) Fuel Element + Rig A Unmodified  
 B Plus Flow Straightener (Modification 1)  
 C Plus Flow Straightener Plus Garter (Modification 4)

Primes (') = Dimples      No Prime = Dimples Removed

**TABLE 2**  
**RESULTS OF STUDENT'S t TEST ON TABLE 1 DATA FOR**  
**LEVELS OF SIGNIFICANCE UP TO 5 PER CENT**

Comparison between		Dimples on Rig?	Other Information	Sensors Considered	Level of Significance
Pumps 1 + 2	Pumps 1 + 3	Yes	(For both positions B5, E1 and all F.E) assemblies A, B, C	Shield plug accelerometer and rig accelerometers	1%
Pumps 1 + 2	Pumps 2 + 3	Yes		Shield plug accelerometer	1%
Pumps 1 + 2	Pumps 1 + 3	Yes	For B5 only, and all F.E.	Shield plug accelerometer	2%
Pumps 1 + 2	Pumps 2 + 3	Yes	Assemblies A, B, C	Shield plug accelerometer	2%
Pumps 1 + 3	Pumps 2 + 3	Yes	B5 and E1, and A, B, C	Shield plug accelerometer and rig accelerometers	2%
F.E. Assembly A	F.E. Assembly B	No	E1 only, all pump combinations	Shield plug accelerometer	2%
Pumps 1 + 3	Pumps 2 + 3	No	B5 only, and A, B, C	Rig accelerometers	5%
Pumps 1 + 3	Pumps 2 + 3	No	B5 and E1 and A, B, C	Shield plug accelerometer	5%
Pumps 1 + 2	Pumps 2 + 3	Yes	B5 and E1 and A, B, C	Rig accelerometers	5%
F.E. Assembly A	F.E. Assembly A'		B5 only, all pump combinations	Shield plug accelerometers and rig accelerometers	5%

Legend: A - Unmodified Fuel Element + rig  
 B - Fuel Element with integral flow straightener + rig  
 C - Fuel Element with flow straightener and garter + rig  
 Prime (') - Dimple      No Prime - Dimple Removed

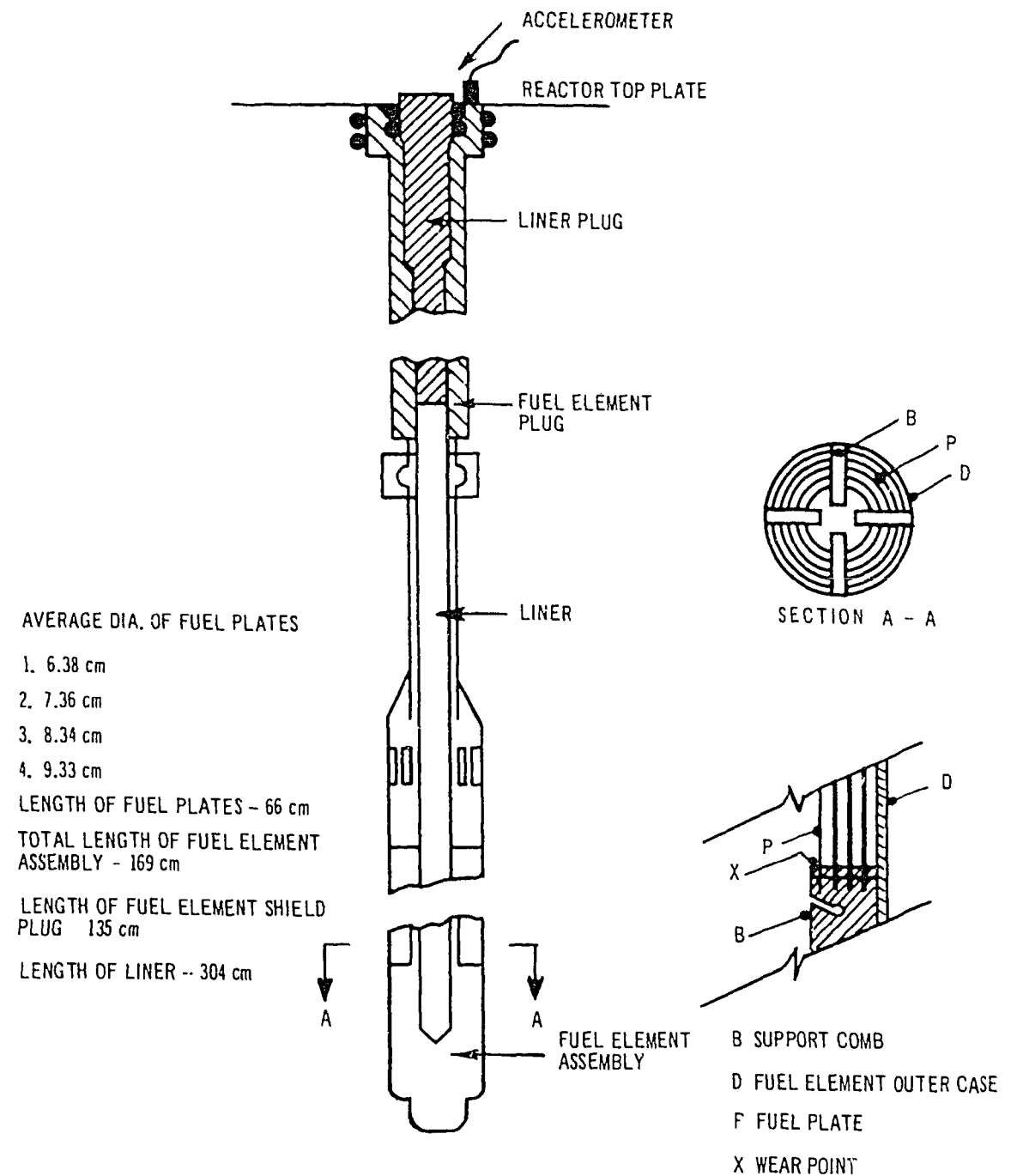

**FIGURE 1. HIFAR FUEL ELEMENT AND LINER**



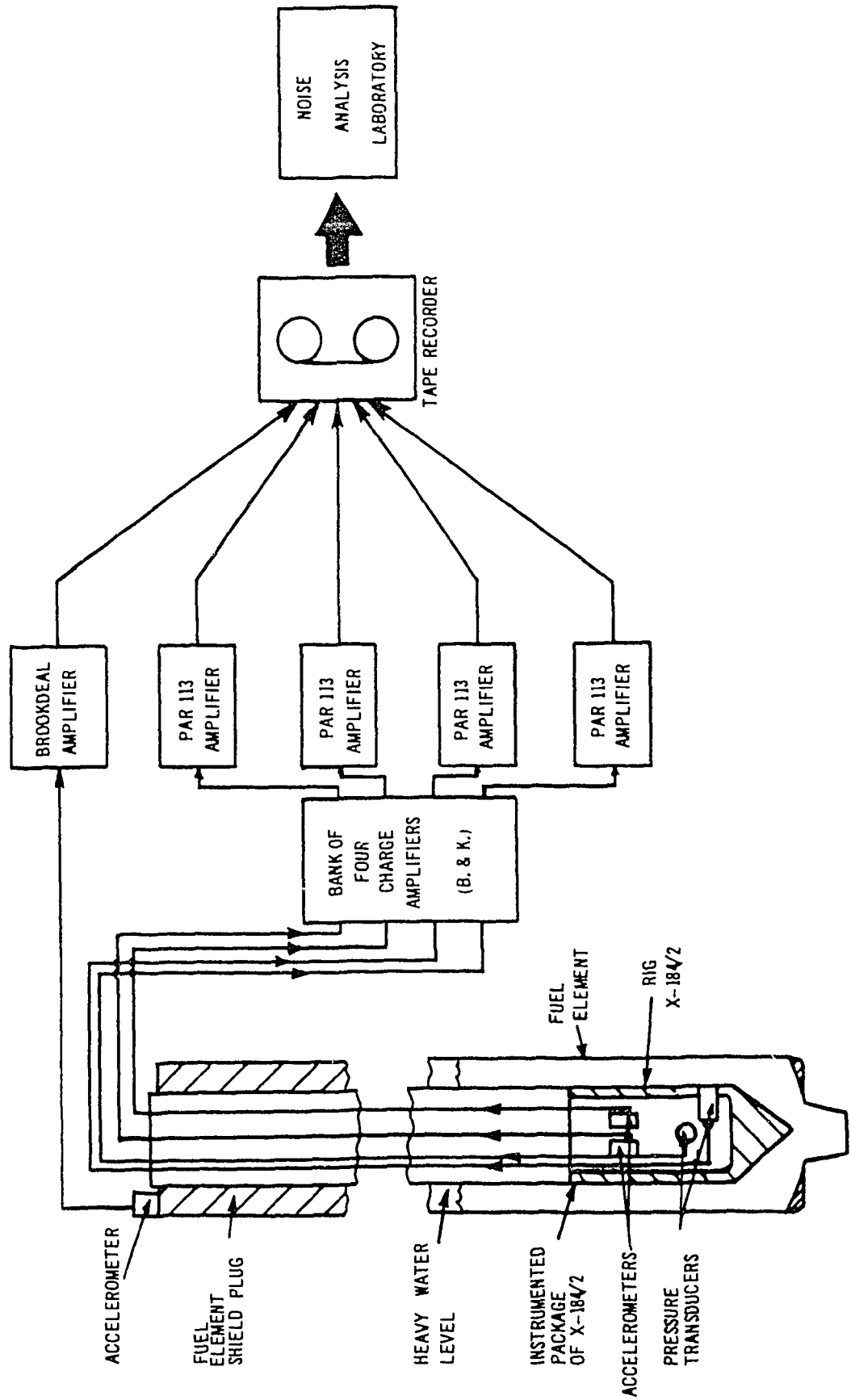

FUEL ELEMENT ASSEMBLY

FIGURE 2. SCHEMATIC DIAGRAM OF RIG X-184/2 AND BLOCK DIAGRAM OF INSTRUMENTATION

SCHEMATIC DIAGRAM OF CORE POSITIONS

Pump Combination	A1	A2	A3	A4		
(1 + 2) →	0.055	0.046	0.093	0.023		
(2 + 3) →	0.047	0.052	0.096	0.068		
(1 + 3) →	0.048	0.051	0.108	0.071		
B1	B2	B3	B4	B5	B6	
0.073	0.053	0.045	0.076	0.082	0.075	
0.075	0.059	0.048	0.081	0.085	0.086	
0.079	0.060	0.048	0.088	0.084	0.089	
	C1	C2	C3	C4	C5	
	0.064	0.048	0.057	0.060	0.078	
	0.067	0.054	0.060	0.062	0.069	
	0.067	0.055	0.061	0.064	0.069	
D1	D2	D3	D4	D5	D6	
0.055	0.049	0.066	0.071	0.046	0.031	
0.052	0.049	0.073	0.076	0.051	0.033	
0.053	0.050	0.073	0.071	0.048	0.034	
	E1	E2	E3	E4		
	0.039	0.044	0.052	0.037		
	0.034	0.044	0.044	0.037		
	0.039	0.059	0.044	0.031		

(units of  $g_n^2$ ;  $g_n = 9.8 \text{ m sec}^{-2}$ )

FIGURE 3. MEAN-SQUARE ACCELERATIONS FOR X-184 FOR THREE PUMP COMBINATIONS

SCHEMATIC DIAGRAM OF CORE POSITIONS

Pump Combination	A1	A2	A3	A4
(1 + 2) →	0.0071	0.0181	0.0013	0.0009
(2 + 3) →	0.0043	0.0177	0.0013	0.0013
(1 + 3) →	0.0088	0.0180	0.0014	0.0013

B1	B2	B3	B4	B5	B6
0.0044	0.0123	0.0030	0.0134	0.0241	0.0166
0.0041	0.125	0.0031	0.0136	0.0051	0.0121
0.0043	0.127	0.0034	0.0132	0.0049	0.0120

C1	C2	C3	C4	C5
0.0085	0.0017	0.0208	0.0026	0.0063
0.0023	0.0020	0.0204	0.0026	0.0024
0.0035	0.0016	0.0199	0.0026	0.0026

D1	D2	D3	D4	D5	D6
0.0006	0.0007	0.0029	0.0019	0.0018	0.0008
0.0009	0.0007	0.0111	0.0020	0.0019	0.0009
0.0008	0.0008	0.019	0.0020	0.0021	0.0011

E1	E2	E3	E4
0.0013	0.0010	0.0034	0.0012
0.0014	0.0013	0.0036	0.0009
0.0017	0.0013	0.0037	0.0023

(units of  $g_n^2$ ;  $g_n = 9.8 \text{ m sec}^{-2}$ )

**FIGURE 4. MEAN-SQUARE ACCELERATIONS FOR HOLLOW FUEL ELEMENT SHIELD PLUG FOR THREE PUMP COMBINATIONS**

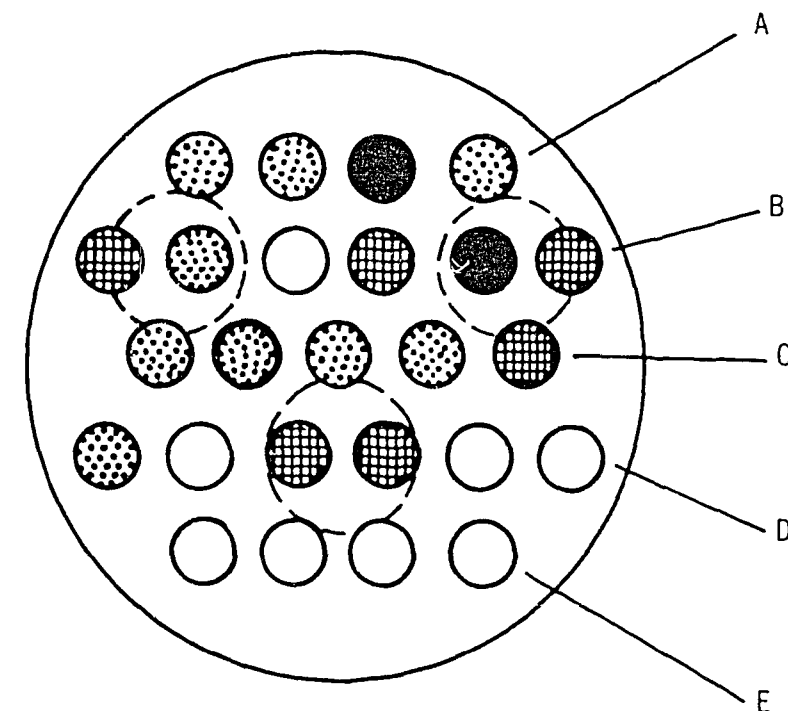

**HIFAR CORE CONFIGURATION**

POSITION OF RISERS SHOWN BY DOTTED LINES

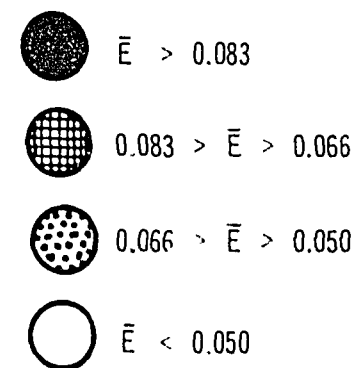

**FIGURE 5. GROUPED REPRESENTATION OF AVERAGE VIBRATION LEVEL  $\bar{E}$  FOR X-184**

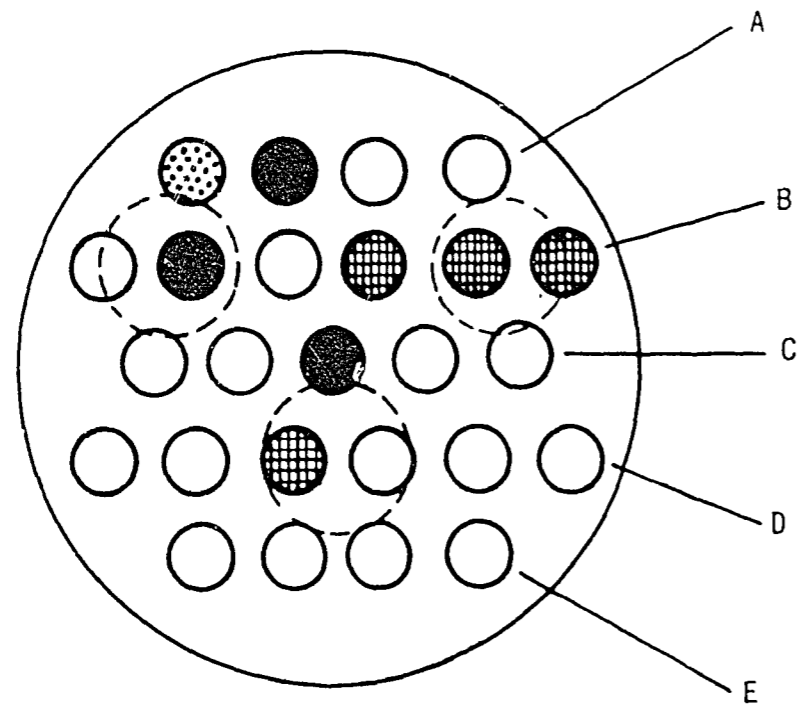

HIFAR CORE CONFIGURATION  
 POSITION OF RISERS SHOWN BY DOTTED LINES





-   $\bar{E} > 0.015$
-   $0.015 > \bar{E} > 0.01$
-   $0.01 > \bar{E} > 0.005$
-   $\bar{E} < 0.005$

FIGURE 6. GROUPED REPRESENTATION OF AVERAGE VIBRATION LEVEL  $\bar{E}$  AT THE HOLLOW FUEL ELEMENT SHIELD PLUG

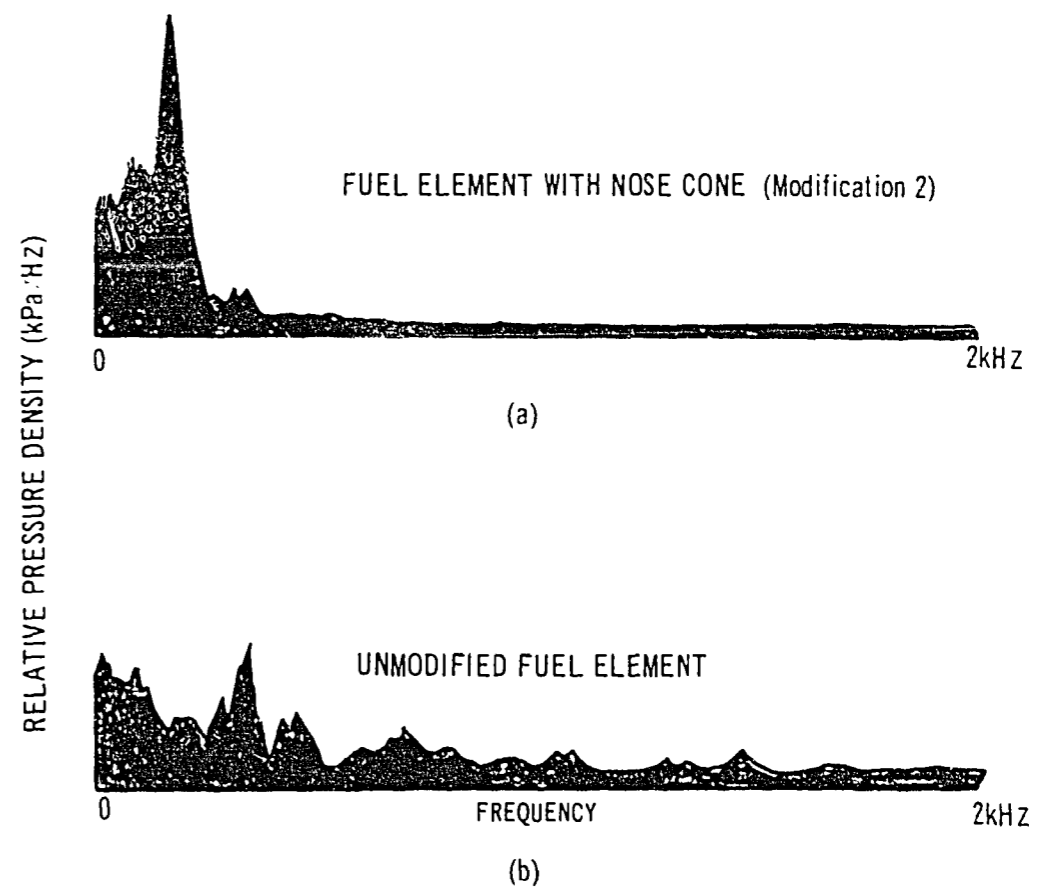

FIGURE 7. NOISE SPECTRA OF X-184 PRESSURE TRANSDUCER

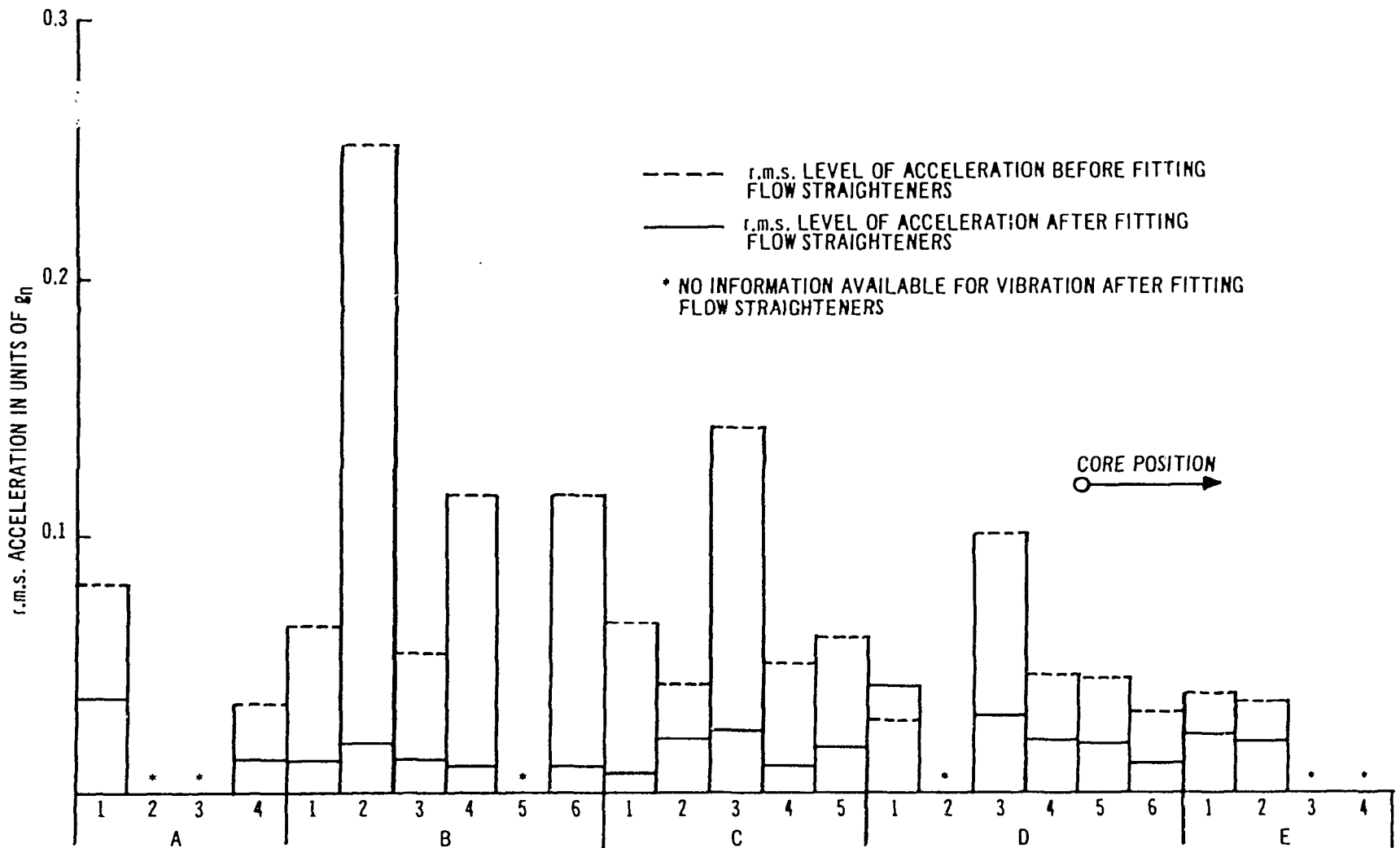

FIGURE 8. BAR CHART COMPARISON OF r.m.s. ACCELERATION LEVELS FOR THE HOLLOW FUEL ELEMENT SHIELD PLUG BOTH BEFORE AND AFTER FITTING FLOW STRAIGHTENERS

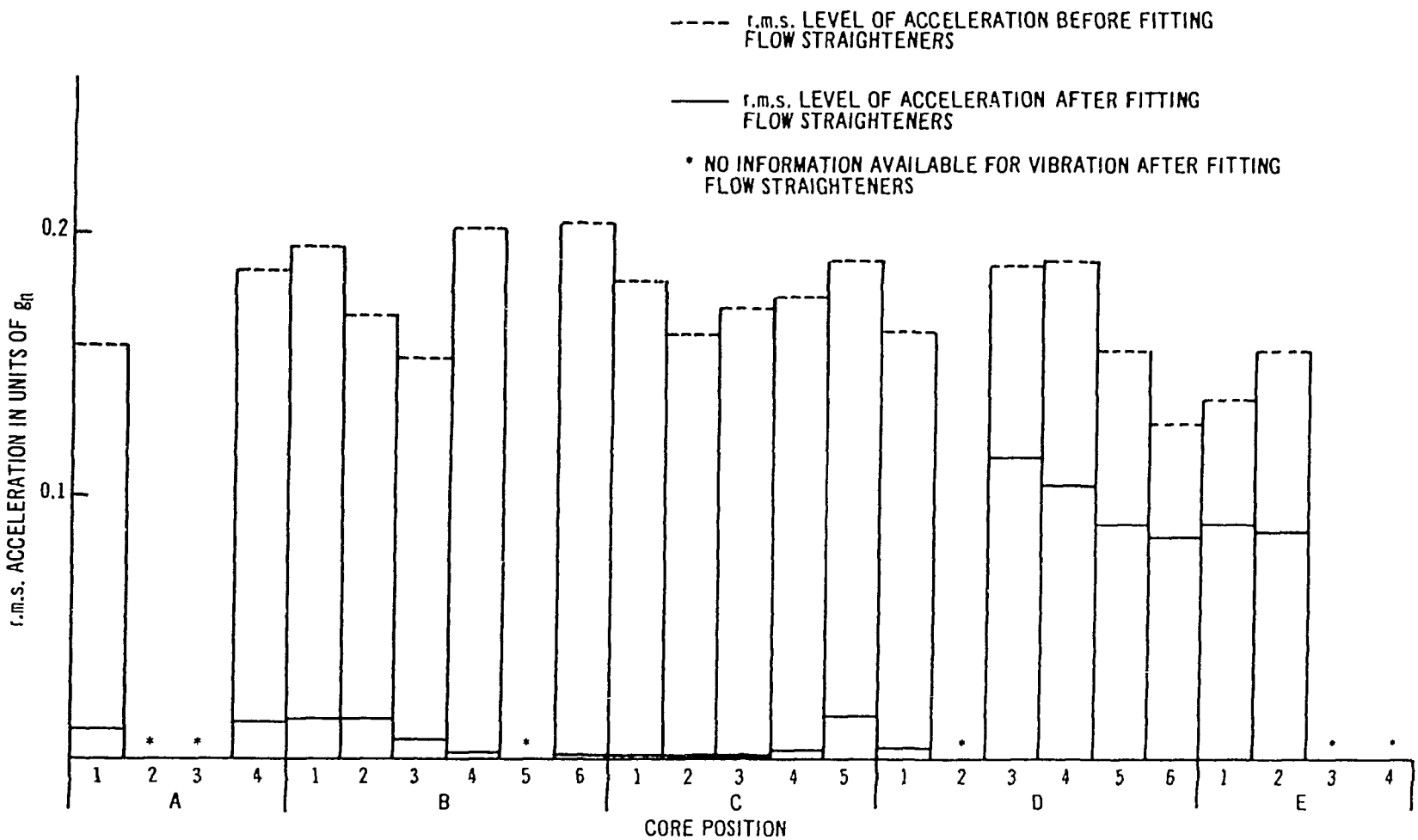

FIGURE 9. BAR CHART COMPARISON OF r.m.s. ACCELERATION LEVELS IN THE RIG BOTH BEFORE AND AFTER FITTING FLOW STRAIGHTENERS

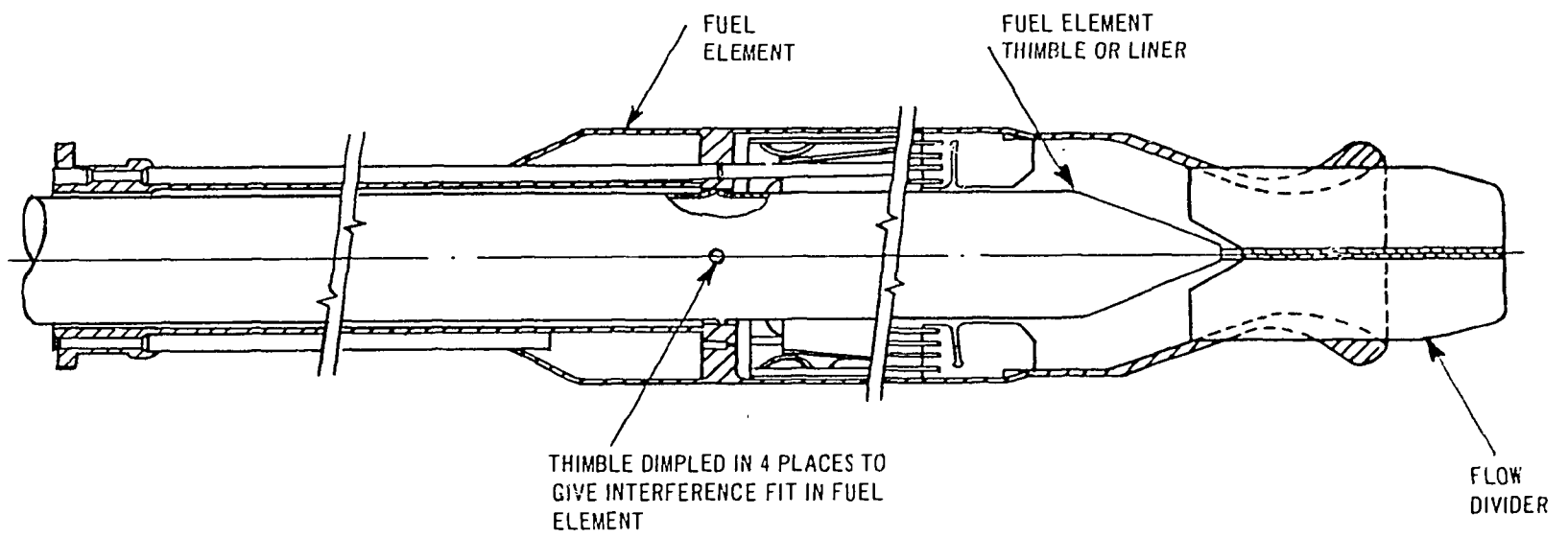

FIGURE 10. VIBRATION TEST MODIFICATION 1 TO HIFAR  
FUEL ELEMENT DESIGN DRAWING

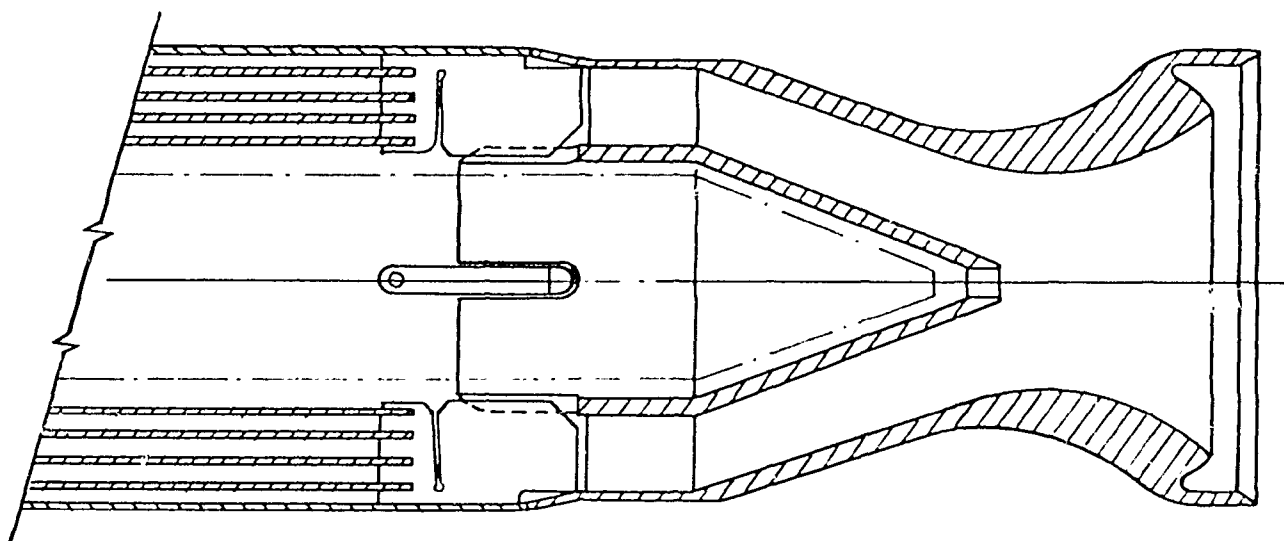

FIGURE 11. VIBRATION TEST MODIFICATION 2 TO HIFAR  
FUEL ELEMENT DESIGN DRAWING

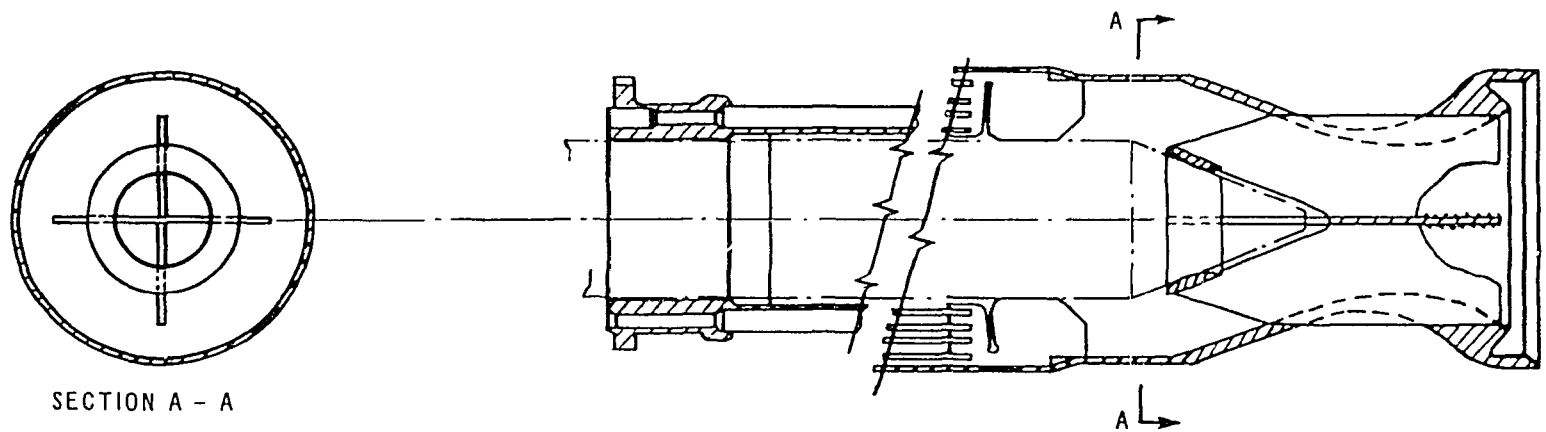

FIGURE 12. VIBRATION TEST MODIFICATION 3 TO HIFAR  
FUEL ELEMENT DESIGN DRAWING

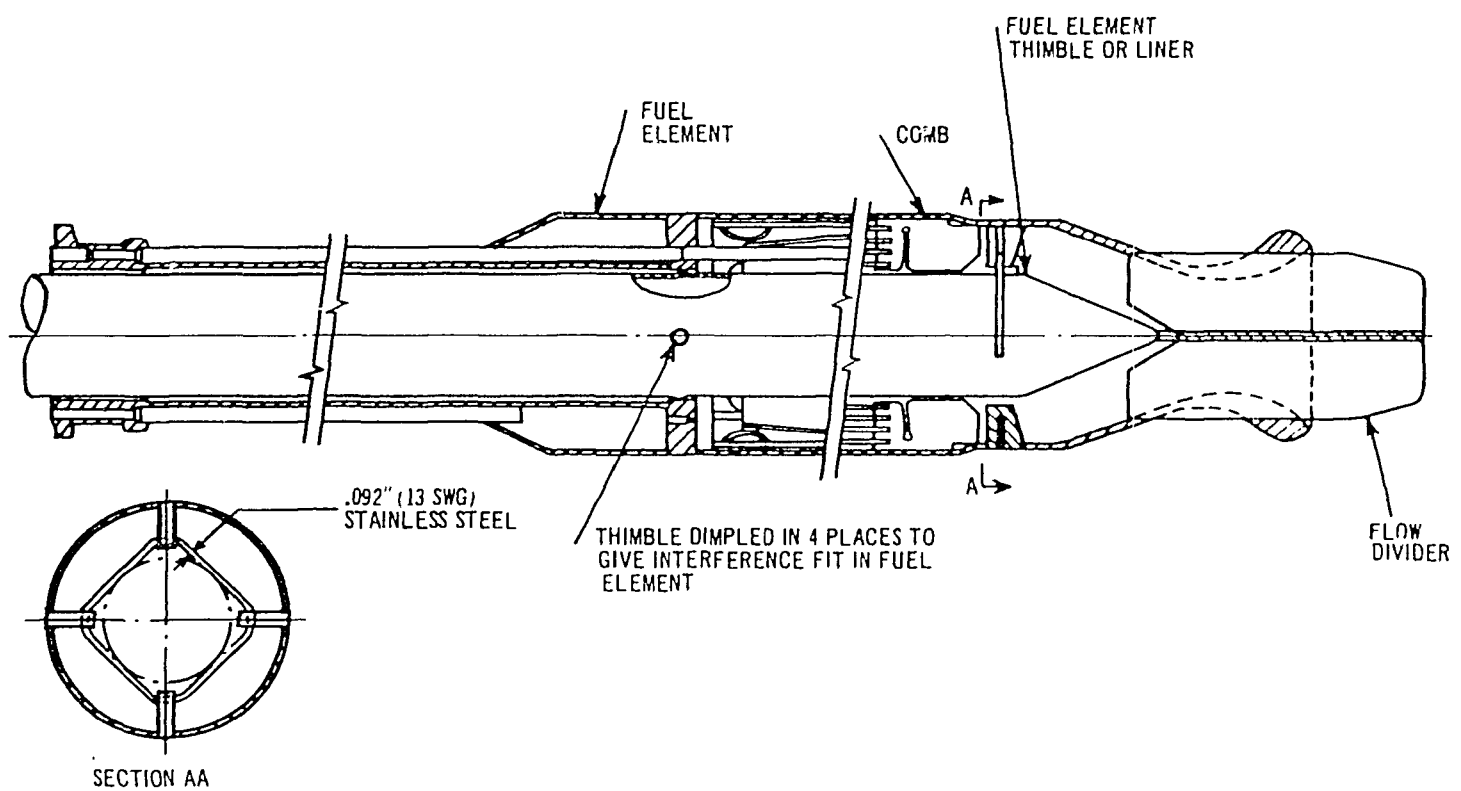

FIGURE 13. VIBRATION TEST MODIFICATION 4 TO FUEL  
ELEMENT DESIGN DRAWING

## APPENDIX

### DESCRIPTION OF MODIFICATIONS TO FUEL ELEMENTS

The vibration-induced damage to fuel element assemblies often occurred at the position where the liner was free to move and impact the lower fuel plate combs. Consequently, an important part of the design philosophy was to provide a more positive means of locating and supporting the lower end of the liner and also to change the structure of the flow in an attempt to reduce the driving forces. Some of the modifications were also designed to assist in the location of the fuel element when loading it into the reactor.

The following modifications to the Mark 4/5A fuel element were manufactured:

#### Modification 1 - Integral Flow Straightener

A four-vane flow straightener was fabricated from thin aluminium plate and welded onto the guide nose section of a fuel element, as shown in Figure 10. The straightener protruded into the nozzle in the plenum chamber when loading and this assisted the operation.

#### Modification 2 - Nose Cone

A sleeve in the form of a truncated cone was fitted within the guide nose of the fuel element to provide more positive location for the liner at its lower end. This provided also hydraulic damping of the liner motion via coolant flow through the small clearance between it and the cone assembly. This modification is shown in Figure 11.

#### Modification 3 - Flow Straightener and Conical Seat

A four-vane flow splitter with a conical ring attached to its top was welded to the guide nose section of a fuel element as shown in Figure 12. The conical ring allowed positive location of the end of the liner. This design required special clamps at the top of the shield plug to 'lock' the liner to the fuel element assembly.

#### Modification 4 - Flow Straightener and Spring Garter

The flow straightener is similar to that described in modification 1 but with the addition of a stainless steel spring garter to further constrain the motion of the liner. This modification was designed to achieve many of the benefits of modification 3 without the need for special clamps on the shield plug. The modification is depicted in Figure 13.

PRINTED OFFSET BY THE  
AAEC RESEARCH ESTABLISHMENT