

AECL-6199

**ATOMIC ENERGY
OF CANADA LIMITED**



**L'ÉNERGIE ATOMIQUE
DU CANADA LIMITÉE**

**APPLICABILITY AND INTERPRETATION OF
FRACTURE TEST METHODS FOR METALS***

by

W.J. LANGFORD

***Presented at Seminar on Failure Analysis and Fracture Control,
Queen's University, Kingston, Ontario, 8—9 May 1978**

**Chalk River Nuclear Laboratories
Chalk River, Ontario**

May 1978

APPLICABILITY AND INTERPRETATION OF FRACTURE TEST METHODS
FOR METALS*

by

W.J. Langford

*Presented at Seminar on Failure Analysis and Fracture Control,
Queen's University, Kingston, Ontario, 8-9 May 1978

Chalk River Nuclear Laboratories
Chalk River, Ontario K0J 1J0
May 1978

AECL-6199

Applicabilité et interprétation des méthodes
d'essai de fracture pour les métaux*

par

W.J. Langford

- * Rapport présenté au colloque de l'analyse des défaillances et du contrôle des fractures, tenu les 8 et 9 mai 1978 à Queen's University, Kingston Ontario.

Résumé

Les essais de fracture sont généralement effectués parce que l'on est convaincu (quelquefois sans trop savoir pourquoi) que de tels essais garantiront un certain niveau de protection contre la défaillance des métaux. Les essais qualitatifs, comme l'entaille en V de Charpy, produisent des résultats que l'on ne peut pas rigoureusement associer à une mesure de la tolérance aux fractures; ils renseignent plutôt sur la qualité du métal à partir de laquelle on peut déduire la tolérance aux fractures. Par contre, les essais quantitatifs donnent des paramètres que l'on peut utiliser directement dans les équations pour déterminer la probabilité des fractures. Les deux types d'essais ont des limitations qu'il faut comprendre; on s'efforce dans ce rapport de décrire les avantages relatifs des deux types d'essais pour une fin particulière et on donne un aperçu de méthodes d'essai, attendues dans un proche avenir, qui agrandiront la portée utile des essais quantitatifs.

L'Energie Atomique du Canada, Limitée
Laboratoires nucléaires de Chalk River
Chalk River, Ontario, K0J 1J0
Mai 1978

AECL-6199

APPLICABILITY AND INTERPRETATION OF FRACTURE TEST METHODS
FOR METALS*

by

W.J. Langford

*Presented at Seminar on Failure Analysis and Fracture Control,
Queen's University, Kingston, Ontario, 8-9 May 1978

ABSTRACT

Fracture tests are conducted usually out of a conviction (sometimes only vaguely defined) that they will guarantee a certain level of protection from metal failure. Qualitative tests, such as the Charpy V-notch, produce results which cannot be rigorously related to a measure of fracture tolerance: rather, they indicate metal quality so that fracture tolerance may be inferred. Quantitative tests on the other hand provide parameters which may be used directly in equations to determine the likelihood of fracture. Both types of tests have limitations which should be understood: the paper tries to provide guidance on the relative merits of either approach for a particular purpose, and gives an insight into near-future test methods which will extend the range of usefulness of quantitative tests.

Chalk River Nuclear Laboratories
Chalk River, Ontario K0J 1J0
May 1978

AECL-6199

1. WHY DO FRACTURE TESTING?

There are several reasons why we conduct tests on specimens to study their fracture behaviour. Underlying all of them is the realisation that breakage is normally an undesirable and unexpected interruption to the useful life of a metal structure. Breakage is frequently associated with economic penalties, and in its more dramatic manifestations, with loss of human life. We know that all metal structures will break if we apply sufficient stress, even though most common structural metals are extremely forgiving. It is the failure of an apparently sound structure, stressed well within its measured strength capability, which concerns us most. And so we try to prevent such failure by qualifying the structural materials using one or more of several test methods.

We can list several reasons for fracture testing:

1. To ensure that a structure will serve for its designed life without failing.
2. To ensure public safety.
3. To compare candidate materials to find the toughest for a given purpose, at an economic cost.
4. To compare the quality of a selected material against a specified standard.
5. To permit us to predict the effects of service factors, such as fatigue or stress-corrosion on material toughness, and thus on a structure.
6. To study effects of metallurgical changes on material toughness.

More than one of these reasons for testing are usually involved in the course of engineering design, material selection, construction, and operation of a metal structure, whether it be a bridge or a bathysphere, a nuclear reactor or an earthmoving machine. The reasons, to a large extent, determine the tests to be chosen.

2. TESTS AND THEIR INTERPRETATION

We can separate toughness tests into two broad groups:

- a) Tests producing data which can be used qualitatively in failure prevention.
- b) Tests producing data which can be used quantitatively in failure prevention.

Depending on the reasons why we are testing, we can choose a test technique from either group, or both. If, for example, we wish to select a steel for use outdoors in an Arctic environment, we would want a test which showed that the steel would not break unexpectedly at the service temperatures. This is a qualitative test, determining material suitability rather than providing a measure of structural performance. If, however, we want to know how flaws, such as cracks, will affect the fracture safety of a structure, then a more quantitative result may be needed. Often, results of both types of test are combined for maximum fracture control.

2.1 Qualitative Tests

Rather early in his development, Man learned that things tended to break more easily if he hit them with something hard and heavy, rather than just pressed them, and impact-induced fracture techniques (stone chipping) were put to constructive use by our early ancestors.

With the rapid development of metals for structures during the Industrial Revolution, a quick check on the fracture toughness of a metal was easily obtained by hitting it with a hammer. In a more precise form, the technique is particularly useful in delineating the change in fracture properties of body-centred cubic metals (predominantly steels) with temperature. Various hammer tests were devised over the last 70 or 80 years, and today the most common test of this type is the Charpy V-notch impact test.

2.1.1 Charpy V-Notch Impact Test

The Charpy V-notch (Cv) impact test is an ASTM standard (1). The standard test specimen (Figure 1) contains a 2 mm deep notch with a root radius of 0.25 mm. The specimen, cooled or heated to the selected test temperature, is supported horizontally at its ends and then struck with a pendulum-mounted hammer. The energy absorbed in fracturing the specimen is recorded directly as a function of the height to which the hammer swings after impact. Normally, three specimens are tested at each of several selected temperatures, and the results are plotted as absorbed energy versus temperature (Figure 2). Other measurements which may be made in this test include lateral strain at the root of the notch (notch contraction) or opposite the notch (MLE, or mils lateral expansion), and percentage of shear fracture in the fracture surface (Figure 2).

Charpy results normally vary with working direction in the material, material thickness, and between different heats of nominally identical material. The Charpy test was developed primarily for use with steels, and minimum Charpy impact energy levels are often specified for steels, sometimes in conjunction with minimum MLE values, as in the ASME Boiler and Pressure Vessel Code, Section III, Nuclear Power Plant Components.

Metallurgical Significance of Impact Energy Curves

The impact energy curve (Figure 2) represents a temperature dependence of the mode of deformation in the steel. At low temperatures (-118°C in this case) fracture occurs by cleavage. This means that the concentrated tensile stresses at the notch tip are sufficiently high to initiate a brittle mode of failure in which the atomic bonds between certain atom planes are broken. There is for all practical purposes no plastic deformation in the fracture process, and the broken specimen exhibits shiny facets which are the cleavage planes in individual crystals. As temperature increases, yield strength decreases, and thus plastic flow becomes easier. The broken Charpy specimen now exhibits shear lips on the edges, and the impact energy curve rises because more kinetic energy is absorbed in plastic work. With further temperature increase, more energy is absorbed by increasing plastic work. Eventually the fracture is 100% plastic fibrous rupture. Above this temperature the impact energy absorption remains essentially unchanged, and is termed the upper shelf energy. Thus the Charpy curve can be thought of as showing the change in amount of plastic deformation with temperature.

It cannot be too highly stressed that an accurate, calibrated test machine is essential (2) and for nuclear industry work, calibration is mandatory. Calibration specimens are available from the U.S. Army Materials and Mechanics Research Centre.

Interpretation of Charpy Data

Having obtained a Charpy curve for a material of interest, some point of the curve is selected as representing the "ductile-to-brittle transition temperature" (TT for short). Unfortunately there are at least three different criteria for selecting the TT, as follows (3).

- 1) Average energy criterion (i.e., the temperature corresponding to an energy that is one-half the difference between maximum and minimum energies).
(223 K, -50°C)*
- 2) The temperature corresponding to an arbitrary value of impact energy such as 20 J (15 ft.lb).
(168 K, -105°C)*
- 3) The temperature corresponding to a certain proportion of crystalline fracture to shear fracture in the fracture surface of the impact specimen (e.g., 50% crystalline, 50% shear).
(223 K, -50°C)*

*The figures in brackets show the TT values for the curves in Figure 2.

The transition temperature may vary considerably depending on the criterion selected, so when reading of a "transition temperature" in the literature, it is obviously important to know the criterion that is being used.

Within the past few years Charpy data have been increasingly related to a ductile-brittle transition temperature obtained in another standard test, the Drop-Weight test (4).

2.1.2 The Drop-Weight Test

This test establishes a reproducible, well defined boundary between ductile and brittle behaviour in steels.

The test specimen (4) is a plate containing a brittle weld on one surface, the weld in turn containing a saw-cut to localize the fracture (Figure 3). The specimen is loaded as a simple edge supported beam with a stop placed below the centre. The stop restricts the deformation to a small amount (3%); thus general yielding is prevented, and the deformation is kept constant for steels of different yield strengths. A weight falls freely between guides to strike the specimen directly opposite the crack-starter. Tests at 5 K (10°F) intervals define precisely the break/no-break temperature. This temperature is termed the Nil Ductility Transition (NDT) temperature and is a very important parameter in modern fracture-safe design of steel structures. It marks the temperature below which fast unstable fracture is highly probable in the presence of even a very small defect: above the NDT temperature, fracture toughness increases rapidly with temperature. This definition is more precise than a Charpy-based transition temperature, as will be shown later.

Because the drop-weight test employs a sharp crack, moving rapidly from the notched brittle weld bead into the test plate, it will come as no surprise to find that the NDT temperature defined by this test correlates well with the beginning of an increase in fracture toughness with temperature measured in quantitative, sharp-crack tests, which I shall describe later. The test provides, therefore, a useful link between the qualitative 'transition temperature' and quantitative 'critical stress intensity' approaches to fracture prevention.

There are other qualitative tests based on impacting of notched specimens, but there is insufficient space here to discuss them all. The Charpy V-notch and the Drop Weight NDT tests are certainly the most common in industrial use today in North America.

One other simple, qualitative test is worth mentioning for comparing and sorting materials.

2.1.3 Notch Tensile Test

The notch tensile test is particularly useful for evaluating the fracture toughness of material in thin sections where Charpy V-notch or Drop Weight tests are not practical. A notch, normally having a 60° flank angle and a tip radius of less than 0.025 mm (0.001 in.) is introduced into a round (circumferential notch) or flat (double edge notch) tensile specimen (Figure 4). The net load-bearing cross section is equal to one-half the gross cross section.

During tensile loading, the notch imposes elastic constraints on the material in the reduced section, raising the load that can be supported by the material (assuming that the material does not fracture below the net-section yield stress).

The net-section ultimate stress is measured and compared with the ultimate tensile strength measured on an unnotched specimen. The ratio

$$\frac{\text{Notched (net-section) ultimate stress}}{\text{UTS of smooth, unnotched specimen}}$$

is termed the Notch Sensitivity Ratio (NSR) of the material.

The test is useful for comparing the effects of heat-treatments, environment, temperature, etc. on the notch sensitivity of the alloy. In ductile materials, or where specimen dimensions are unable to impose considerable elastic constraint at the notch, the NSR can exceed unity. In general, an NSR value of less than about 0.7 is an indication that unstable fracture may occur in service.

Specimens of this type are also able to provide quantitative data if their physical proportions are related to yield strength. This is discussed briefly in a later section.

2.2 Quantitative Tests

2.2.1 Tests to Measure K_{IC}

The principles of linear elastic fracture mechanics are outlined elsewhere (5). Fracture mechanics tests, as presently standardised, have as their objective the measurement of the plane strain fracture toughness of the material, characterised by the critical stress intensity factor K_{IC} . There is no standard test technique for measuring critical K_I values in specimens where full plane strain constraint is not present. [However, I shall present later details of a technique for measuring the 'J-integral' - a technique which is now close to ASTM standardisation. This technique permits a quantitative estimate of fracture toughness where plasticity exceeds that permitted by the linear elastic approach.]

To ensure a valid K_{IC} test result, specimen dimensions must be chosen so that the plastic zone size at the stress intensity (usually a notch extended by fatigue to a sharp crack) is relatively very small. The lower limit of thickness for a valid result on a given material cannot be predicted, and must be determined by trial tests. Specimen dimensions are selected (Figure 5) as multiples of the ratio $(K_{IC}/\sigma_{ys})^2$ (σ_{ys} is the tensile yield stress) which in itself requires initial guessing at the fracture toughness one is trying to measure. For most engineering materials, valid K_{IC} determinations demand large test specimens, but some aerospace materials fracture in plane strain in very thin sections. This is illustrated by the following table.

Material	Yield Strength		Fracture Toughness		Minimum Specimen Thickness to Ensure Plane Strain	
	MPa	(ksi)	MPa $\cdot\sqrt{m}$	(ksi $\cdot\sqrt{in.}$)	mm	(in.)
Carbon steel casting (A216-WCC)	310	(45)	143	(130)	297	(11.7)
Titanium alloy (Ti+6 Al, 6V, 2.5 Sn)	1240	(180)	38	(35)	1.9	(0.075)

EFFECT OF YIELD STRESS AND FRACTURE TOUGHNESS ON TEST SPECIMEN THICKNESS FOR K_{IC} MEASUREMENT

The two specimens in common use today for K_{IC} determinations are the single edge-notched compact tension specimen and the 3- or 4- point bend specimen. Both have fatigue-sharpened deep notches (Figure 5). Test techniques and data analysis for both types are fully explained in the ASTM Standard Method E399 (6). In each case, elastic response is measured as a function of applied load by attaching suitable displacement gauges across the notch.

The load-displacement curves obtained from the tests must be carefully analysed to determine the point of crack instability. Only infrequently will one find a curve exhibiting a distinct, drop-in-load 'pop-in' of the crack following completely elastic loading (Figure 6a). More often the crack extension region is revealed by small step-wise increments in the load-displacement curve (Figure 6b). A scheme of curve analysis now used by ASTM (6) constructs a secant-offset line (Figure 6c) which establishes the upper limit on

permissible deviation from linearity before 'pop-in' is indicated. Assuming that the test record is valid to this point, one proceeds to calculate a provisional K_Q value which is then used to estimate the validity of the test specimen dimensions. If valid, K_Q is equal to K_{IC} : if invalid, a larger specimen must be used in a subsequent test. Other information concerning fracture appearance is also recorded.

Circumferentially notched tensile specimens, basically similar to the ones described earlier, may also be used subject to dimensional limitations. Their principal disadvantage lies in the difficulty of fatiguing an evenly sized crack at the root of the circumferential notch, and for this reason the compact tension or bend specimens are usually preferred.

The fracture mechanics approach is immensely useful, but is limited by the requirement that crack tip plasticity must be very small to avoid invalidating the elastic analysis. Many common engineering alloys are used in sections which are too thin to produce sufficient elastic constraint at flaws large enough to give concern (as indicated in the table above), and considerable local plasticity may be present. Plasticity usually confers increased toughness, through crack blunting, and so K_{IC} values may give an unnecessarily conservative estimate of tolerable flaw size. For the same reasons, it may not be possible to measure a valid K_{IC} in specimens of material in commonly used thicknesses. This limitation has led to intensive study of techniques which can take localised plasticity into account.

2.2.2 The J-Integral

This technique is based on a different mathematical method for defining the situation at the crack tip. The analysis will be discussed in a later paper (7). A precise definition is deliberately circumvented by integrating to find the work done in extending the crack through a small increment while accepting the presence of limited local plastic deformation. The value of the integral is not strongly affected by the actual shape assumed for the work zone close to the crack tip - mathematically defined as a path-independent line integral.

The test technique has developed close to the point of standardization and it extends the usefulness of fracture mechanics into the region where some localised plasticity can be accepted.

All current J-integral tests have in common the measurement of the area under a curve of load versus load point displacement (i.e., force x distance) for a cracked specimen. J is directly related to this area. Both compact tension and bend specimens are suitable, as for fracture mechanics tests.

The steering committee of the ASTM E24-01-09 task group on elastic-plastic fracture has proposed a recommended procedure for determining the critical value of J (J_{IC}). The procedure requires a minimum of four specimens to be tested, each being loaded to give different amounts of crack extension (Figure 7). J (the area under the curve) is calculated for each specimen from the expression

$$J = \frac{2A}{Bb}$$

where A = area under load vs load-point displacement curve.
 B = specimen thickness.
 b = remaining (uncracked) ligament width.

Each value of J so derived is plotted against Δa , the crack extension obtained from each specimen, by heat tinting the specimen after test, then breaking it open.

A 'best line' is drawn through the J points, and a 'blunting line' drawn from the origin to account for plastic deformation preceding the onset of cracking. The blunting line is given by:

$$J = 2\sigma_{flow} \cdot \Delta a$$

$$\text{where } \sigma_{flow} = \frac{\sigma_{yield} + \sigma_{ultimate}}{2}$$

The intercept between the J line and the blunting line is considered to be J_{IC} , the critical value of J at which crack extension commences.

At first sight the procedure seems complicated, but all one is really doing is to work backwards, using measured crack extension, to define the point at which a crack would just start to extend in a material where localised plasticity makes direct measurement very difficult. The work done per unit area of specimen cross section at that point is the critical J value, J_{IC} .

J is formally related to K:

$$J_{IC} = \frac{K_{IC}^2}{E}$$

where E = Young's modulus.

Thus in its present form, J_{IC} is used to find K_{IC} and thus permit a quantitative measurement of fracture toughness from a

specimen probably too small to satisfy the rigorous requirements of K_{IC} tests.

2.2.3 Application of Fracture Mechanics Test Results

The quantitative nature of fracture mechanics test results becomes clear when one recognises that the valid K_{IC} value obtained can be used in an equation which relates K_I to the stresses applied to a structure containing a sharp flaw. In its simplest form, if the elastic analysis of the flaw in its applied stress field shows that the K_I value associated with that flaw is less than K_{IC} , then the structure will not fail.

An example of such a structural relationship is the equation for a through-crack in a pressure vessel, where the one-half critical crack length

$$a_{cr} = \frac{1}{\pi} \left(\frac{K_{IC}}{\sigma} \right)^2 - \frac{1}{2\pi} \left(\frac{K_{IC}}{\sigma_{ys}} \right)^2$$

(i.e., the total critical crack length = $2 a_{cr}$).

where K_{IC} = plane strain fracture toughness obtained in a valid test.

σ = applied tensile stress normal to crack.

σ_{ys} = uniaxial tensile yield strength of material.

A similar expression exists for partial thickness cracks, where the critical crack depth (one-half depth for internal crack)

$$a_{cr} = \frac{K_{IC}^2 Q_{cr}}{1.21\pi \sigma^2}$$

Q_{cr} being a flaw shape parameter for which values are available, e.g., in reference (8).

The literature contains many expressions for calculating K_I factors developed at flaws of various shapes in many different structures (joints, bent plates, holes in rivetted sheets, etc.), which can be used in evaluating the safety of the structure.

3. A CRITICAL ASSESSMENT OF FRACTURE TOUGHNESS TESTS

We have looked at the principal test methods, both qualitative and quantitative. What do they tell us, how can we use the information, and what are the limitations?

3.1 Charpy V-Notch Test

The curve of energy, or notch ductility (MLE) or % shear fracture, against temperature gives a valuable indication of the temperature range below which brittle fracture becomes more probable. It is important to realise that the values associated with a given curve are not fundamental in any way: each steel will show a specific curve, and it must not be assumed that a certain value (say 20 J, 15 ft.lb) provides equal reassurance that fracture is unlikely in all steels.

We noted in discussing fracture mechanics tests that large specimens are frequently required to ensure sufficient notch-tip restraint. This points to one limitation of the Charpy specimen. It is small, and its size is constant and unrelated to the strength of the material under test. The machined notch is not as severe as a sharp crack. It is fairly easy to see then that Charpy data must be used against a wide background of recorded experience, rather than as a set of numbers having significant intrinsic meaning. The necessary wide background is well established for families of common structural steels, and for these materials Charpy criteria provide a quick and inexpensive check of the pedigree. It is becoming increasingly common for more than one Charpy criterion to be measured, to guard against freak results being accepted. As an example, Charpy criteria for U.S. nuclear reactor pressure vessel steels are defined in terms both of absorbed energy and MLE: this ensures that the fracture process absorbs energy in plastic strain rather than simply because the steel is stronger, thus guaranteeing ductility during fracture.

3.2 The Drop Weight Test

By identifying the Nil Ductility Transition (NDT) temperature, the DWT affords a means for simple quality control, and for grouping different types, batches or heats of steels. For many steels, knowledge of the NDT temperature can be translated into safe minimum operating temperatures at a given stress. The Drop-Weight NDT is more reliable than a Charpy V-notch value unless the Charpy value has been calibrated to the NDT temperature for the specific material. Figure 8 illustrates this point: the vessel steel was capable of brittle fracture (i.e., below its NDT temperature) although Charpy tests indicated that it was very tough.

The DWT is applicable primarily to steels in the 18 to 50 mm thickness range. NDT temperature is not affected by section sizes above about 12 mm because the restraint is established by the small notch configuration and limited deformation, rather than by specimen cross section. The test is a "go/no-go" type and yields the single result of NDT temperature - no other data can be obtained.

3.3 Fracture Mechanics Tests

The fracture mechanics tests are intended to provide an index of minimum fracture toughness under conditions of maximum elastic constraints. It was shown earlier that, for valid determination of plane strain fracture toughness (K_{IC}) large specimens are frequently needed. This requirement often demands large test machines, which together with the need for fatigue-tipping of starter notches, use of sensitive displacement gauges, and the difficulties in interpreting the load-displacement curves, makes the tests expensive and unsuited to production testing.

As shown earlier, plane strain loading conditions in engineering structures imply large section thicknesses in low strength materials or alternatively, high yield strengths in thin sections. For structures where plane-strain constraints are unobtainable, K_{IC} values from valid tests suggest low levels of fracture toughness that in fact cannot be attained in the structure. While this approach may be considered conservative and therefore safe, it ignores the fact that the ductility of the material (i.e., formation of large plastic zones at stress concentrations) raises the failure stress to high levels. Consequently, limitations could be imposed on the designer which would not be justified in relation to the load-bearing capability of the structure.

Fracture mechanics tests are most usefully employed in laboratory investigations of high strength or thick engineering materials, and particularly in studying fatigue and environmental effects on crack behaviour. Fatigue crack growth rates are related to the range of stress intensity (ΔK) applied.

We can expect the J-integral test to become more common as researchers and designers seek to develop quantitative fracture toughness data for more ductile materials. The prospect of defining critical flaw sizes for many structures is attractive, and provides much impetus for the J-integral and similar elastic-plastic techniques. For conditions where large-scale plasticity develops, no generally applicable quantitative technique yet exists.

4. LINKS BETWEEN QUANTITATIVE AND QUALITATIVE TESTS

4.1 K_{IC} and the NDT Temperature

Since both types of test aim at the same objective, viz. to provide a measure of a material's propensity for fracture, it is natural that researchers have sought to link the two approaches. The critical stress intensity factor, K_{IC} , can be considered a material property in much the same way as yield stress, and it too varies with temperature. For steels, K_{IC} shows a marked increase with temperature corresponding to the increase in Charpy energy, and the K_{IC} versus temperature curve can conveniently be indexed to the NDT temperature determined by the drop-weight test. An example of this indexing, for U.S. nuclear reactor pressure vessel steels, is shown in Figure 9 (9). Indexing in this manner suggests that a given

level of fracture toughness (K_{IC}) is found at a certain temperature interval from the NDT temperature. Thus in comparing two steels of similar types, having different NDT temperatures, it is reasonable to assume that their fracture resistance (defined by K_{IC}) will be different at a given temperature. To put it another way, one of them can be used at a lower temperature than the other and yet give the same degree of fracture protection. This is implicit in the purely qualitative Charpy test technique, but the indexed curve allows quantitative interpretations to be made. Obviously, curves have to be developed for various groups of steels before K_{IC} can be inferred simply from a knowledge of the NDT temperature and the desired service temperature. Such a 'wide background' has already been shown to be essential even for interpreting Charpy data, after which the material user is still largely unable to quantify the degree of fracture protection. K_{IC} curves indexed to NDT temperature may become very valuable tools in the future.

4.2 K_{IC} from Charpy Tests?

Test equipment is now commercially available for obtaining much more information from the Charpy test. The striking hammer is equipped with strain gauges, and when the specimen is struck an autographic record is created on a cathode ray screen showing load versus time. The curve can be analysed using similar procedures to those described for K_{IC} tests. Notch restraint is sometimes increased by machining side grooves into the test specimen, and for appropriate materials and strengths, K_{IC} can be determined. The techniques are not yet in common use, but will probably develop increasing support, combining as they do the cheapness and speed of Charpy testing with the predictive ability of fracture mechanics. Fundamental limitations are imposed by the small specimen size which will limit the technique to stronger alloys.

It may be possible to derive K_{IC} values from ordinary Charpy tests, without the need for specially instrumented equipment. Empirical correlations between K_{IC} and Charpy shelf energy levels have been developed, the two best-known perhaps being:

$$K_{IC}^2 = 5 \sigma_{yp} \left[(\text{CVN}) - \frac{\sigma_{yp}}{20} \right] \quad \dots(10) \text{ and}$$

$$K_{IC} = 15.5 (\text{CVN})^{\frac{1}{2}} \quad \dots(11)$$

[where CVN = Charpy shelf energy (ft.lb), K_{IC} in ksi $\sqrt{\text{in.}}$, σ_{yp} in ksi.]

Since considerable plastic displacements precede crack extension in both Charpy tests (at upper shelf values) and in J-integral tests, Rice suggested (12) that it was not surprising that some correlation should exist between Charpy and K_{IC} values. It seems quite likely, then, that more formal correlations will be

developed between Charpy test results and fracture mechanics values as the field of elastic-plastic fracture becomes more fully understood.

5. SUMMARY

For convenience, we have discussed fracture toughness tests as either 'qualitative' or 'quantitative', depending on the subsequent application of the data they provide. The Charpy test is widely used as a qualitative test for steels, and, because of the large volume of information available for comparison, Charpy data provide a reliable indication of fracture toughness for common types of steels. But they give no fundamental information about a structure's ability to withstand flaws. One is advised to use Charpy test results carefully in specific fracture-control plans where the properties of the steel are not very well known. For comparing steels, and for quality control of steel products, the Charpy test is invaluable. Whatever the purpose of the Charpy test, an accurately levelled and calibrated machine is essential.

Many other qualitative tests have been omitted because of the limitations of space: dynamic tear tests, crack-arrest tests, and variants of the Charpy. All have in common measuring the response of a notched specimen to a suddenly-applied load, and all provide some estimate of the probable serviceability of a metal component. For the same reason, I have not discussed the excellent U.S. Naval Research Laboratory Fracture Analysis Diagram, which condenses the known behaviour of steels into a usable fracture control scheme based on qualitative tests.

The quantitative tests are well established for conditions in which a high degree of elastic restraint is present at the tip of a sharp crack. The critical stress intensity factor generated is directly usable in an expression to determine critical flaw size in a component. The techniques are now being extended to maintain their predictive ability into the elastic-plastic regime.

Other tests of this type have been left out because they are not yet in widespread use: however, both the crack-resistance (R) curve and crack-opening displacement (COD) tests are being actively pursued in many laboratories. The latter is advanced in Britain to the level of being a British Standard Draft for Development.

The division of tests into 'qualitative' and 'quantitative' types allowed a comparison of the principal modern approaches to fracture control. It was shown though that the difference is becoming less pronounced with time: correlations are available, and theoretical justification of the correlations is developing rapidly. The desired end product is a quantitative fracture control plan based on simple, inexpensive tests.

In conclusion, one should remember that a clear definition of the reason for testing goes a long way towards selecting a suitable test method. With the objective clearly understood, well-planned fracture tests and careful interpretation of their results will provide valuable supporting information for the designer and user of metal products. Reference 5 is an excellent review of basic theory and application of fracture control in metal structures. You will note that Part 10 of the Annual ASTM Standards includes four of the twelve references given for this paper. The volume is worth study by anyone interested in more detailed knowledge of fracture test techniques. In addition, the Special Technical Publications of ASTM provide excellent source books on current research into fracture testing and its application, and are recommended to those interested in pursuing the subject further.

6. REFERENCES

1. Standard Methods and Definitions for Mechanical Testing of Steel Products, ASTM Standard Method A370, ASTM Annual Standards, Part 10.
2. Standard Methods for Notched Bar Impact Testing of Metallic Materials, ASTM Standard Method E-23, ASTM Annual Standards, Part 10.
3. A.S. Tetelman and A.J. McEvily, Jr., Fracture of Structural Materials, Wiley, New York, 1967.
4. Standard Method for Conducting Drop Weight Test to Determine Nil Ductility Transition Temperature of Ferritic Steels, ASTM Standard Method E-208, ASTM Annual Standards, Part 10.
5. See, for example, Rolfe, S.T., and Barsom, J.M., "Fracture and Fatigue Control in Structures", Prentice-Hall, New Jersey, 1977.
6. Standard Test Method for Plane Strain Fracture Toughness of Metallic Materials, ASTM Standard Method E-399, ASTM Annual Standards, Part 10.
7. Hosbons, R.R., "Future Trends in Fracture Mechanics Theory and Applications". Atomic Energy of Canada Limited, report AECL-6198, June 1978.
8. Fifth Report of Special ASTM Committee on Fracture Toughness Testing, Materials Research and Standards, 4, 1964, p.107.
9. PVRC Recommendations on Toughness Requirements for Ferritic Materials, Welding Research Council Bulletin 175, August 1972.
10. Barsom, J.M., Rolfe, S.T., Special Technical Publication 466, p.281, ASTM Philadelphia, 1970.

11. Sailors, R.H., Corten, H.T., Special Technical Publication 514, p.164, ASTM, Philadelphia, 1972.
12. Rice, J.R., et al, Special Technical Publication 536, p.231, ASTM, Philadelphia, 1973.

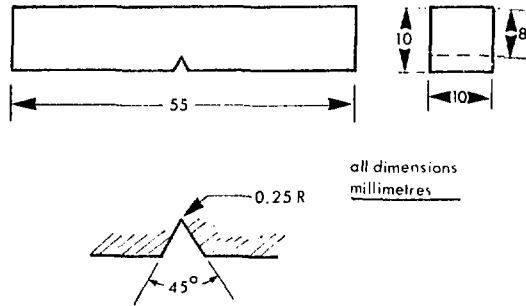

FIGURE 1: Charpy V-Notch Impact Specimen

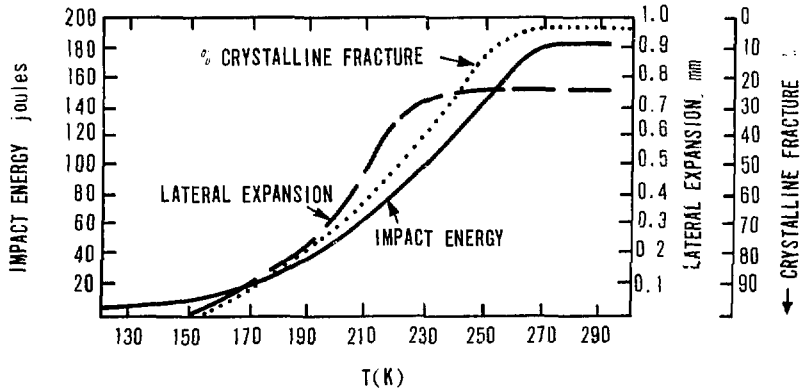

FIGURE 2: Effect of temperature on impact energy, lateral expansion, and fracture mode of Charpy V-notch specimens of a 3.5% Ni steel.

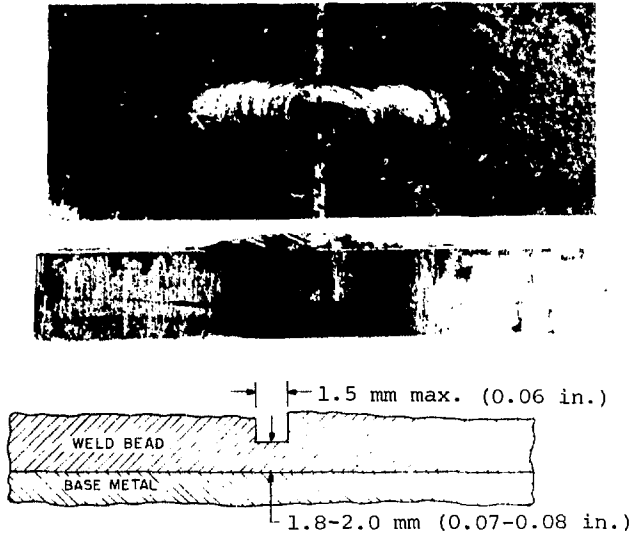

FIGURE 3: Drop-Weight Test Specimen

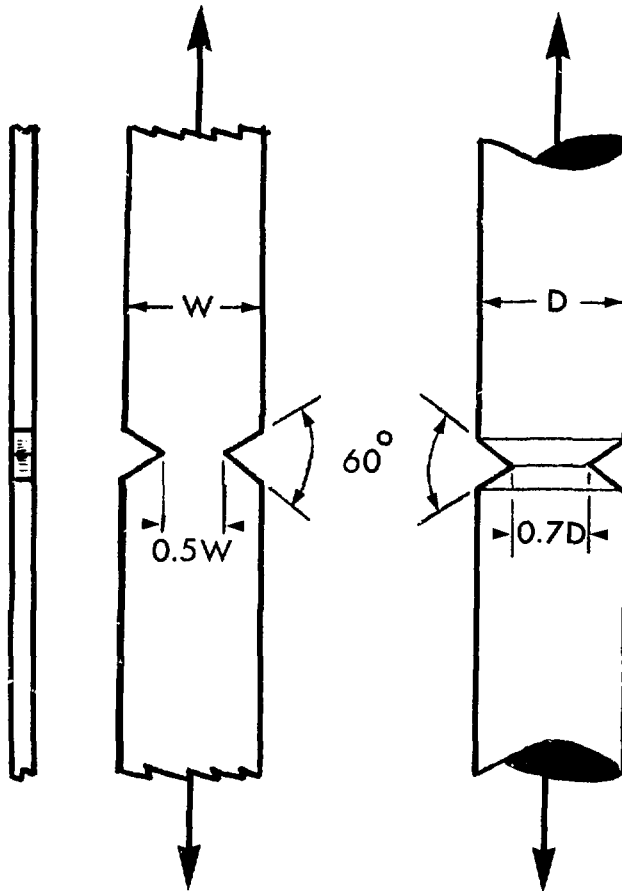

Fig. 4 Notch Tensile Specimens

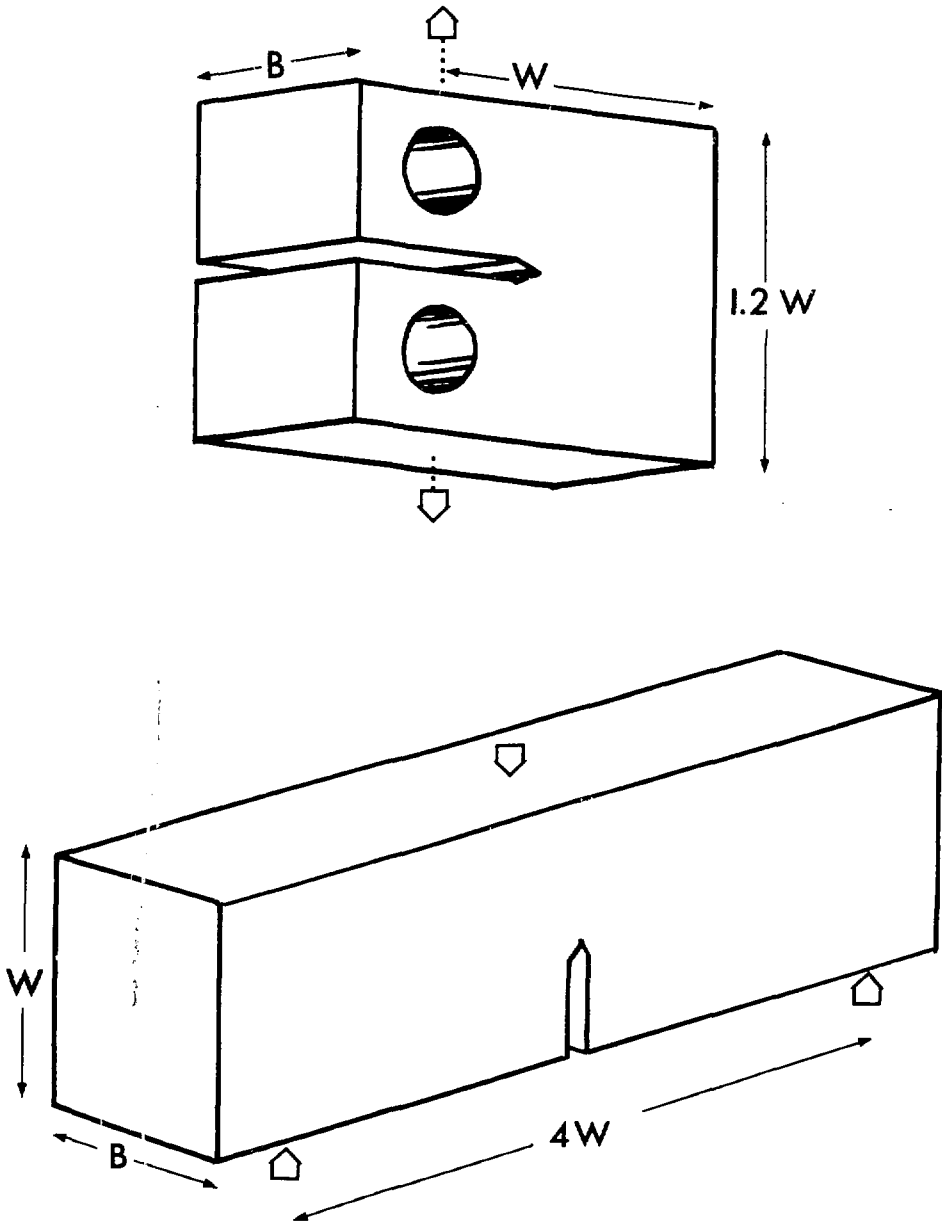

Fig. 5 Relative proportions of (top) compact tension and (bottom) 3-point bend fracture toughness specimens. Typically, thickness $B = 0.5 \times$ depth W .

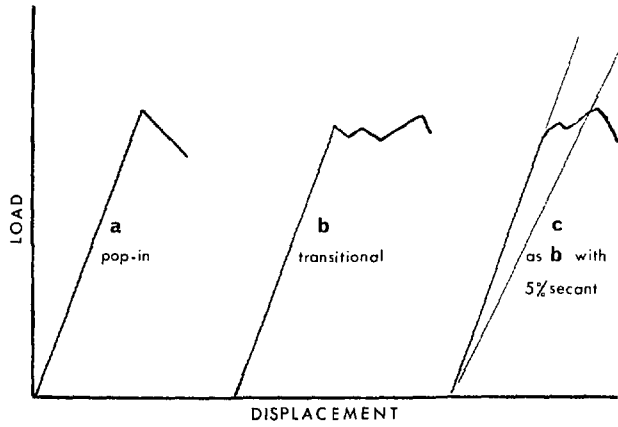
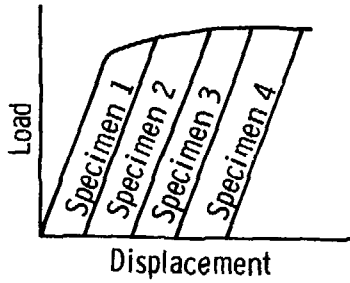
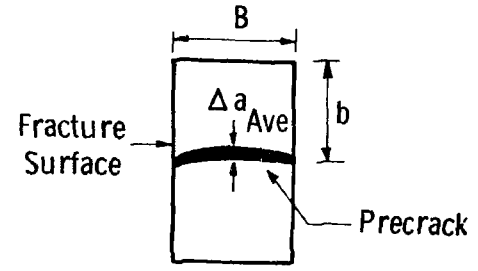

Fig. 6 Typical load-displacement curves in fracture mechanics tests.



(a) Load identical specimens to different displacements



(b) Heat tint and measure average crack extension

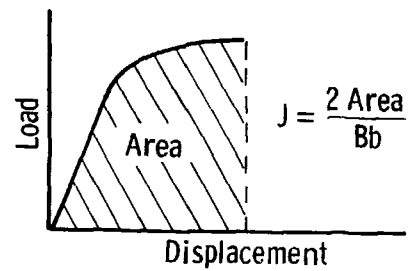

(c) Calculate J for each specimen

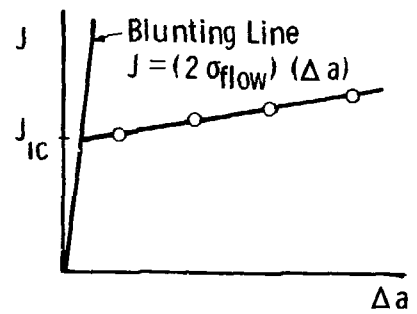

(d) Plot J vs Δa find J_{IC}

Fig. 7 Procedure for Determining J_{IC}

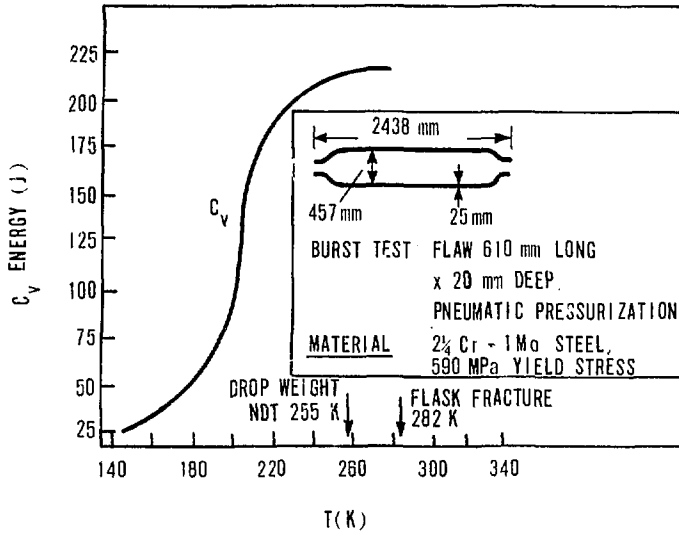

FIGURE 8: Charpy V-notch curve compared with Drop-Weight NDT temperature for material of a flawed flask which fractured during testing.

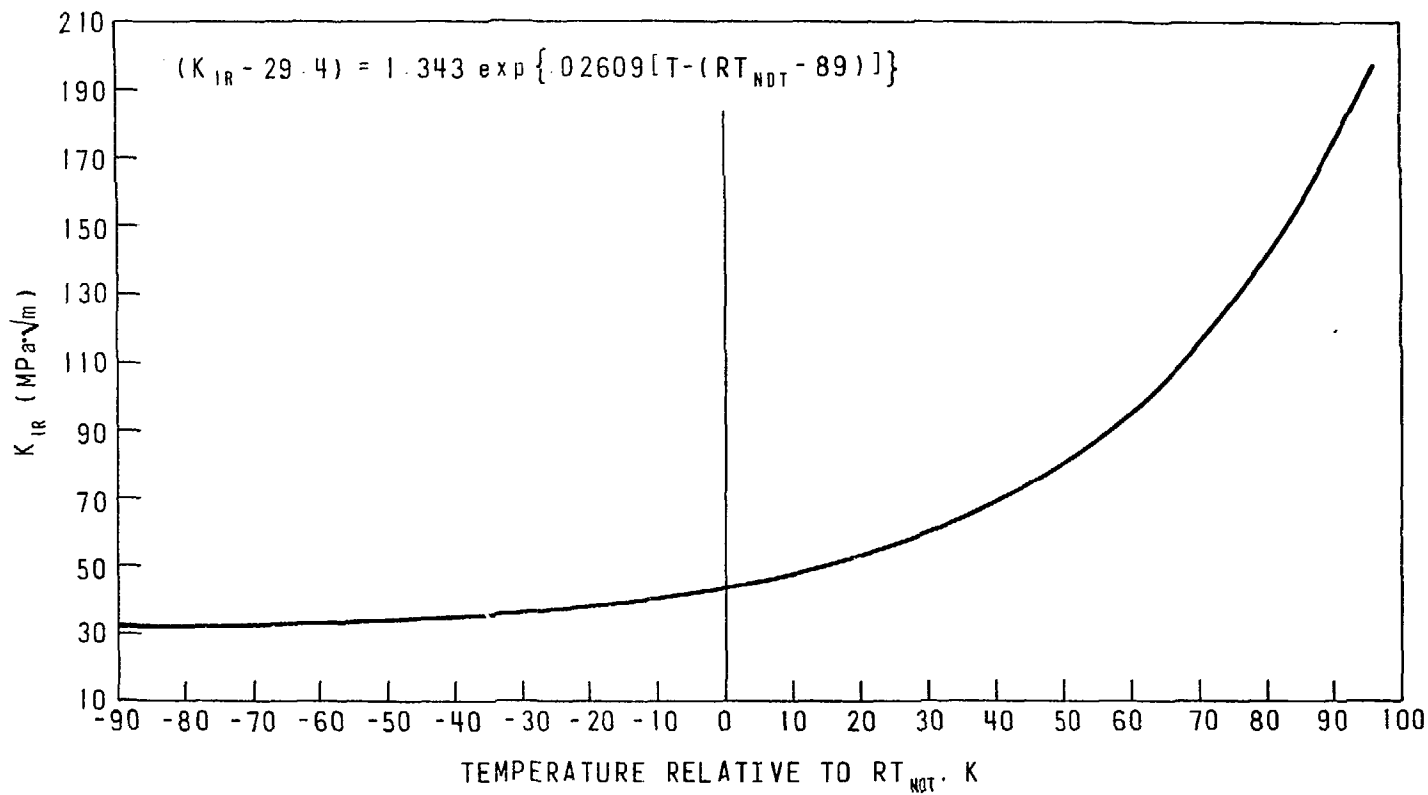

FIGURE 9: Lower bound curve of reference K_{IC} value relative to a reference nil ductility transition (NDT) temperature. After (9).

The International Standard Serial Number

ISSN 0067-0367

has been assigned to this series of reports.

**To identify individual documents in the series
we have assigned an AECL-number.**

**Please refer to the AECL-number when
requesting additional copies of this document
from**

Scientific Document Distribution Office

Atomic Energy of Canada Limited

Chalk River, Ontario, Canada

K0J 1J0

Price \$3.00 per copy

1430-78