

High Resolution 16-channel ECG Tester Simulator for Online Digital-to-Analogue Conversion of Data from PC

Tatyana Neycheva¹, Todor Stoyanov¹, Roger Abächerli², Ivaylo Christov¹

¹ Institute of Biophysics and Biomedical Engineering, Bulg. Acad. of Sci., Sofia, Bulgaria

² Biomed Research and Signal Processing, Schiller AG, Baar, Switzerland

Abstract

Recent design of electrocardiographic simulators should be consistent with the international standard IEC 60601-2-47 issued 2012, which recommends the measurements, detections and interpretative statements of the ECG to be tested by digitized ECGs signals taken from five standard databases.

In accordance to this recommendation we designed a high-resolution ECG tester simulator for direct digital-to-analogue conversion of data from PC. The signals selected from a database are sent from the PC to the Simulator via USB. The prototype has 16 independent channels, high sampling frequency of 2 kHz, and 286 nV/bit amplitude respond of the analogue output. The power-line interference is minimized by a galvanic isolation of the communication between the PC and the simulator. The need of build-in circuit for a Wilson Central Terminal is avoided by the use of 12-Standard-leads to 8-primary-leads transfer formulas.

In-house PC software in Visual C is developed to select and control the operation mode of the simulator. The transmitted signals are real-time visualized on the PC monitor.

1. Introduction

The integration of advanced data processing algorithms in the modern electrocardiographs impede, and in some cases make impossible the implementation of the standardized procedures for the testing of analogue devices. Specific implementations of digital filters for mains interference elimination, drift and electromyographic noise suppression often include nonlinear processing functions, which excludes the application of testing procedures based on linearity of the transfer characteristic, typical for the older generation of electrocardiographs and the developed testers for them. For that reason Dotsinsky *et al.* [1] proposed a testing sequence of triangular pulses and sinusoidal waveforms, suitable for checking the amplitude-frequency response,

the antitremor filter, the baseline suppression, and the time constant of the electrocardiographs. The test sequence included bipolar triangular pulse (1 mV, 20 ms), monopolar triangular pulse (1 mV, 40 ms), monopolar triangular pulse (1 mV, 200 ms), and sinusoidal waveforms of different frequency.

Vasilevich and Prilutskii [2] designed a generator of 9 types of signals for testing of electroencephalographs and electrocardiographs. Generator of artificial electrocardiograms (ECG) like signals was constructed by Caner *et al.* [3]. An opportunity for adding noise at a range of 0 to 20 dB is provided.

Nowadays some sophisticated electrocardiographs provide measurements, detections and interpretative statements for ECG. This requires a new philosophy of the simulators' design – they should be able to reproduce real ECGs. Devices meeting this requirement and containing ECGs recorded in their RAM (or internal/external FLASH memory) were constructed by: Kontodimopoulos *et al.* [4] with AHA database and pacemakers recordings; Mudrov *et al.* [5] with recordings of atrial flutter, atrial fibrillation, tachycardia, Wolff-Parkinson-White syndrome, ventricular blocks, etc.; Dotsinsky *et al.* [6] with recordings of disturbances that accompany the emergency ECG recordings, such as: cardiopulmonary respiration, movement of the patient's cable, moving of the patient's arms, continuous body tremor, frequent and profound respiration (gasp), etc; Martínez *et al.* [7] with one-channel recordings sent from a PC, to the internal RAM by RS 232.

The international standard IEC 60601-2-47, 2012 [8], approved the use of digitized ECGs from 5 standard databases: American Heart Association (AHA), Massachusetts Institute of Technology (MIT), Noise Stress Test (NST), Creighton University (CU), European Society of Cardiology (ESC). The standard provides also information on which one of the databases is suitable for the specific test: QRS detection, heart rate measurements, ventricular ectopic beat, supraventricular ectopic beat, ventricular flutter and fibrillation, atrial flutter and fibrillation, measurement of ST segment deviations, detection of ST segment changes.

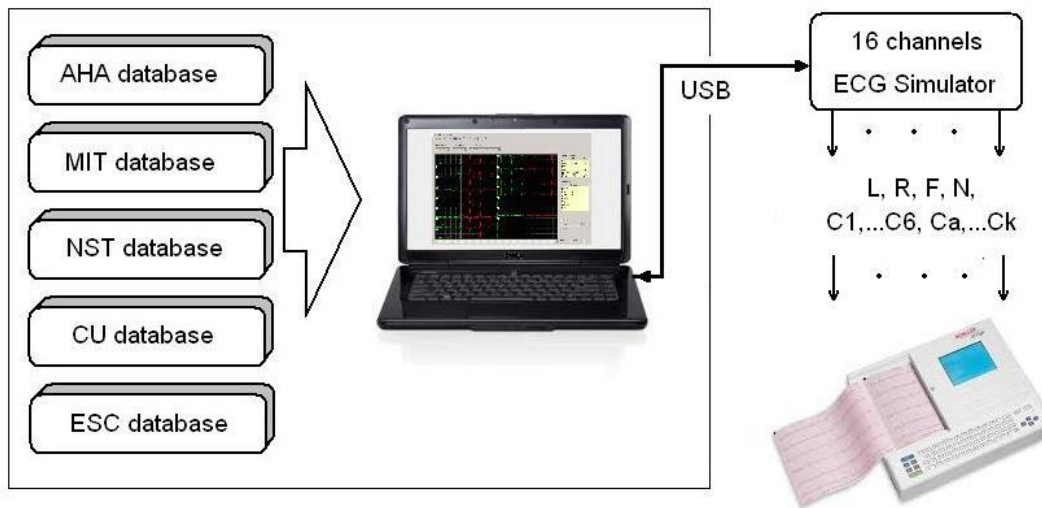

Figure 1. Principal diagram of the simulator

Iliev and Tabakov [9, 10] designed an ECG simulator without internal RAM, but with a direct connection to a PC by RS 232, in an attempt to satisfy the requirements for testing of the ambulatory electrocardiographic systems with a huge amount of digital data. Koebele *et al.* [11] designed their simulator on the same principal, but with a step further using the universal serial bus (USB). They called the method, with a certain dose of ingenuity, “life ECG simulator”.

We have created a prototype of a 16-channels ECG simulator for a direct digital-to-analogue conversion (DAC) from a PC. That design fully coincides with the requirements of the 601-2-47 Ed2 2012 Standard for quality control of the ambulatory ECG systems by the huge amount of digital data from approved databases. The conversion characteristics as number of channels, sampling frequency and amplitude resolution are significantly exceeding those of the known in the literature ECG simulators.

2. Simulator concept

Our purpose was to develop 16 independent channels simulator to reproduce any kind of physiological (for example: electrocardiographic, encephalographic, electrogastrographic, etc.) and test signals with high amplitude and frequency resolution. In case of ECG, the 16-channels are provided for the 10-channels of the 12-Standard ECG leads (L, R, F, N, C1÷C6), plus any kind of additional leads configuration, other bipolar leads, etc., for example one-intercostal higher chest leads C1h÷C3h, that recently proved to be better diagnostically defined than C1÷C3 in the study of Brugada syndrome [12].

The principle diagram is presented in [Figure 1](#). The selected signals are taken from a database and sent from the PC to the Simulator via USB. The digital data is online converted to analogue by the Simulator and sent to its 16 outputs.

We used a 4-channels sigma-delta audio DAC PCM4104 to achieve high frequency and amplitude resolution. This integrated circuit is popular among the consumers of electronic components because of its high-performance at a relatively low cost. The characteristics of the Simulator are:

- 16 independent channels. Four DAC chips (24-bits) are used for this purpose;
- sampling frequency of 2 kHz;
- amplitude respond of 286 nV/bit of the analogue output.

The block diagram of the main components of the ECG simulator is shown in [Figure 2](#).

The Simulator operation is controlled by a microcontroller Cortex STM32F105RCT6, having the necessary periphery and execution speed. The signals are received from the PC by USB port at a speed of 3 Mbps. They are converted in microcontroller suitable serial format by an IC FT232RL, and then fed to the microcontroller’s USART communication port. The microcontroller sends the data to DAC1, DAC2, DAC3, and DAC4 by two I2S communication buses. One communication bus is used by 2 DACs, and this is controlled by the DACs in-house communication protocol “Long Frame TDM Data Format” allowing the DAC which SUB pin is being connected to GND, to obtain the first data pack. Respectively the DAC, whose SUB pin is connected to VDD, receives the second data pack. Signals

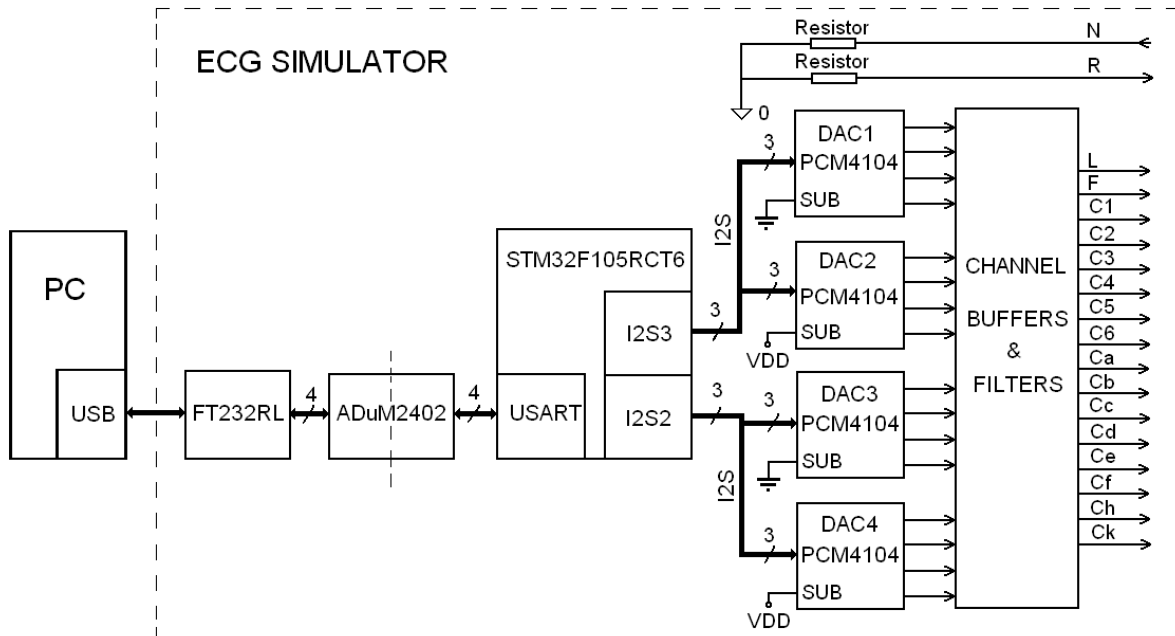

Figure 2. Block diagram of the simulator

from all channels pass through buffer and low pass filter with a cut-off frequency of 2 kHz. Resistors of 1 k Ω are serially inserted to each of the outputs (L, F, C1,..., C6) to simulate skin-to-electrode contacts. In fact the skin-to-electrode impedance is extremely variable and unpredictable, ranging between 0 and 206 k at 10 Hz, and in most instances decreasing in time [13]. In order to minimize the power-line interference, especially at a resolution of 286 nV, a galvanic isolation of the USART communication is used. Appropriate solution for this purpose is the use of 4-channels isolators with integrated DC-DC converter ADuM2402 of Analog Devices. Their isolation voltage is 5000V and the maximum transfer rate is up to 10 Mbps. The power supply of the Simulator is by a rechargeable battery (6V, 1.3Ah).

In-house PC software in Visual C is developed to select and control the Simulator's operation mode. It can operate under any Windows platform. Using this software, the operator can visualise the appropriate database, select specific ECG from the database; select a part of the record or the whole record to be continuously repeated. The transmitted signals are real-time visualized. The ECGs of some databases have just few leads recordings (2 leads in the AHA database, for example). By the PC in-house software, this recordings can be generated to a chosen channel of the Simulator (L, F, C1, C2, C3, C4, C5, C6). All signals with a sampling rate of less than 2 kHz, are linearly interpolated to 2 kHz for a better reproduction.

The program window of the PC in-house software is shown in Figure 3. The green signals on the left are already sent, while the red ones on the right are ahead of

sending.

Transfer formulas according to the work of Dotsinsky *et al.* [14] are used to obtain the 'primary' leads, or these that are expected to appear at the electrodes of right arm (R), left arm (L), right leg (N), left leg (F), and at the chest electrodes (C1-C6) in a 12 standard leads acquisition. As pointed out in this article, one primary lead must be selected to be a signal reference with zero potential. We chose R = 0 as such a reference

$$I = L - R, \text{ therefore } I = L$$

$$II = F - R, \text{ therefore } II = F$$

$$C_i = V_i + WCT, \text{ where } i=1\div 6$$

WCT is the Wilson Central Terminal, defined by:

$$WCT = (R + L + F)/3; \text{ in our case}$$

$$WCT = (L + F)/3 = (I + II)/3$$

Therefore $C_i = V_i + (I + II)/3$

By the use of these transfer formulas the build-in circuit for generation of a Wilson Central Terminal in the Simulator [10] is avoided. WCT does not take part in the above formulas of the chest electrodes (C1-C6). The primary leads are calculated by the PC software.

References

- [1] Dotsinsky IA, Christov II, Daskalov IK. Assessment of metrological characteristics of digital electrocardiographs. *Jour Clin Eng* 1996;21:156-60.
- [2] Vasilevich MY, Prilutskii DA. A generator for testing signals of electroencephalographs and electrocardiographs. *Biomed Eng* 2004;38:162-4.
- [3] Caner C, Engin M, Engin EZ. The programmable ECG simulator. *J of Med Syst* 2008;32:355-9.

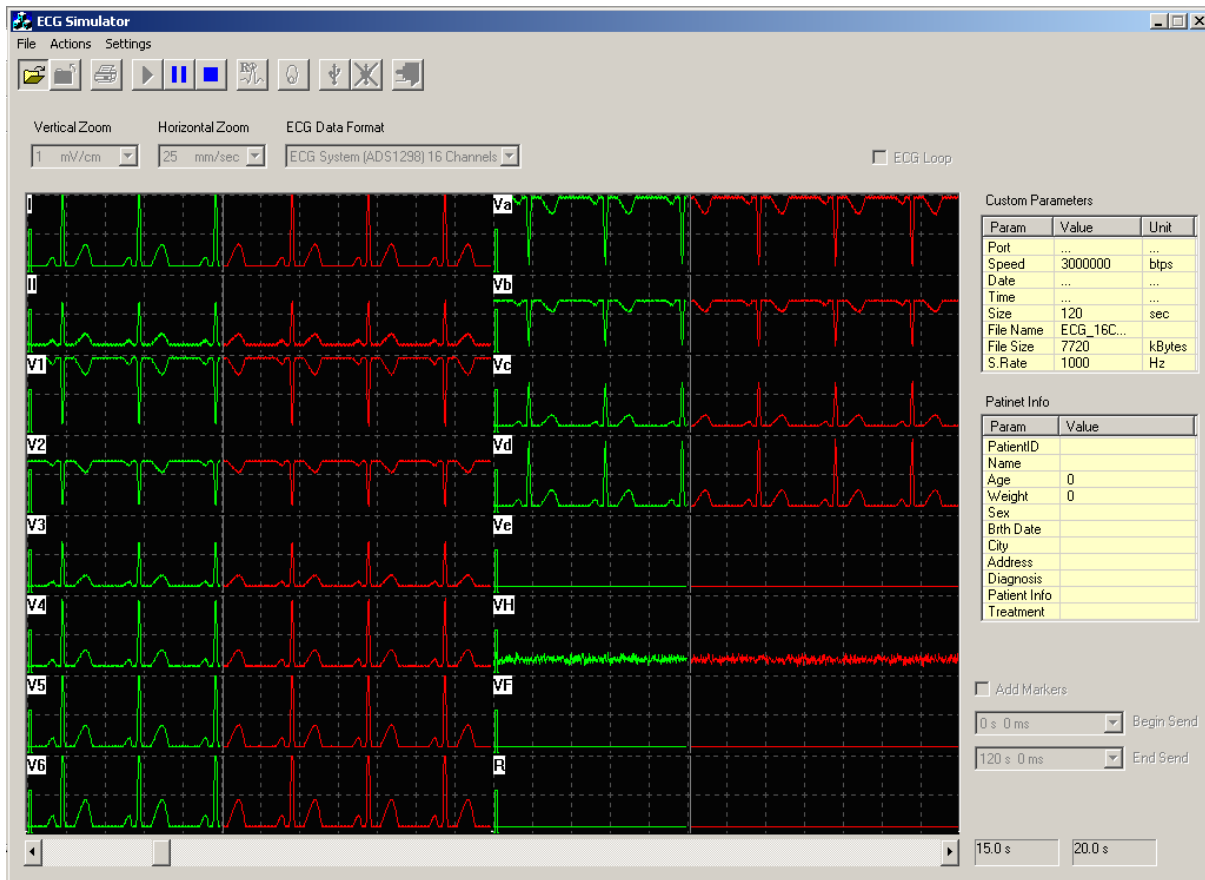

Figure 3. Programme window of the PC in-house software.

- [4] Kontodimopoulos N, Pallikarakis N, Christov I, Daskalov I. In-house development of test equipment for quality control and training Case study: a prototype ECG simulator-tester, *Med Eng & Phys* 1998;20:717-21.
- [5] Mudrov T, Krasteva V, Jekova I. Microcontroller-based ECG simulator prototype, *Proceedings of 13th Int Conf "Electronics 2004"*, Sozopol, 22-24 September, 2004;1:86-91.
- [6] Dotsinsky I, Jekova I, Christov I. Simulator for movements accompanying the emergency electrocardiogram recordings. *Proceedings of 8th Int Conf "Electronics 99"*, Sozopol, 23-25 September, 1999;2:8-31.
- [7] Martínez AE, Rossi E, Nicola Siri L. Microprocessor-based simulator of surface ECG signals. *16th Argentine Bioengineering Congress, Journal of Physics*, 2007, doi:101088/1742-6596/90/1/012030.
- [8] IEC International Standard 601-2-47 Ed. 2 Medical electrical equipment part 2-47: Particular requirements for the basic safety and essential performance of ambulatory electrocardiographic systems, © IEC, 2012.
- [9] Iliev I, Tabakov S. System for adjustment and test of algorithms for ECG-data processing. *Proceedings of 15th Int Conf "Electronics 2006"*, Sozopol, 20-22 September, 2006;3:77-80.
- [10] Iliev I, Tabakov S. A 12-channel multifunctional ECG simulator. *Electrotechnika & Electronica E+E*, 2007;7-8:36-40.
- [11] Koebele J, Heinke M, Iser B. Soundcard based multichannel live-ECG simulator for research, development and education. *Biomed Tech* 2012;6:s331-2.
- [12] Batchvarov V, Christov I, Bortolan G, Behr E. Principal component analysis of the QRS complex during diagnostic ajmaline test for suspected Brugada syndrome. *Computing in Cardiology* 2010;37:501-4.
- [13] Berson AS, Pipberger HV. Skin-electrode impedance problems in electrocardiography, *Am Heart J* 1968;76:514-25.
- [14] Dotsinsky I, Christov I, Daskalov I. Twelve-lead electrocardiogram obtained by eight channels *Electrotechnika & Electronica E+E* 2002;1-2:10-2.

Address for correspondence.

Ivaylo Christov
 Institute of Biophysics and Biomedical Engineering,
 Bulgarian Academy of Sciences,
 Acad. G. Bonchev str., blok 105
 Sofia 1113
 Bulgaria.
Ivaylo.Christov@biomed.bas.bg