

Performance Analysis of Node-Disjoint Multipath Routing for Mobile Ad-hoc Networks based on QoS

Jay Kumar Jain¹, Devendra Kumar Jain², Anuradha Gupta³

*Department of Computer Applications
Maulana Azad National Institute of Technology^{1,2}, OIST³
BHOPAL, INDIA*

Abstract— Recently, quality-of-service routing in dynamic, wireless multi-hop ad hoc networks becomes a hot research topic, and various QoS protocols are proposed. Even so, popular QoS routing protocols rarely provide multiple routes. Once links break due to node mobility, establishment of new routes leads to large control overhead and more end-to-end delay. In MANETs to support multimedia applications such as video and voice require an efficient routing protocol and quality of service (QoS) mechanism. Node-Disjoint Multipath Routing Protocol (NDMR) is a practical protocol in MANETs: it reduces routing overhead dramatically and achieves multiple node-disjoint routing paths. In MANETs QoS support is an important issue as best-effort routing is not efficient for supporting multimedia applications. This paper presents a novel adaptation of NDMR, QoS enabled NDMR, which introduces agent-based SLA management. This enhancement allows for the intelligent selection of node-disjoint routes based on network conditions, so fulfilling the QoS requirements of Service Level Agreements (SLAs).

Keywords: MANET; Node-disjoint; multipath; Agent-based SLA management; Quality of Service.

1. INTRODUCTION

Popularity of wireless technology and the ongoing continuous developments in this field has made mobile ad hoc networks (MANETs) a popular area of research.

Nowadays, real-time and multimedia applications in MANETs require QoS supports. The success of Mobile ad hoc networks can be attributed to its rapid deployment features and its infrastructure less-ness. These are characterized by multihop wireless connectivity, frequently changing network topology and the need for efficient dynamic routing protocols [1]. Static nodes such as base stations are not there in the network. Each mobile node has the capability to operate both as a host as well as a router, forwarding packets to other mobile nodes in the network that may not be within direct wireless transmission range of each other. The design and development of reliable and efficient routing protocols in such a network is, therefore, a challenging issue.

As compared to the proactive protocols [2], On-demand routing protocols use much lower routing load and are therefore, widely used. Ad Hoc on-demand Distance Vector (AODV) [3] and Dynamic Source Routing (DSR) [4] are the two most extensively studied on-demand ad hoc routing protocols. The limitation of both of them is that they build and rely on a unipath route for each data transmission.

Whenever there is a link break on the route, each of the two protocols needs to initiate a new route discovery process. In single-path routing protocols, route maintenance may be performed after routes fail therefore, data transmission will be stopped while the new route is getting established. On the other hand, multipath routing protocols perform the route maintenance process even if one route fails among the multiple routes. To perform the route maintenance process before all routes fail, the network must always maintain multiple routes. This can help in the reduction of data transmission delays caused by link failure [10]. But, on the other hand, this also results in a high routing load. On-demand multipath routing protocols can alleviate this problem by establishing multiple routes between the source and the destination node during one route discovery process. A new route discovery is initiated only when all the paths failed or only one path is available.

This paper presents an approach built on the Node-Disjoint Multipath Routing Protocol (NDMR). NDMR has two novel aspects compared to the other on-demand multipath protocols: it reduces routing overhead dramatically and achieves multiple node-disjoint routing paths [5].

The rising popularity of multimedia applications in the commercial environment and the ever growing requirements of mission-critical applications in the military arena have proved the best-effort service futile in meeting all requirements in most situations. This has led to the emergence of QoS support in mobile ad hoc networks as an important area of research. Compared to the demands of traditional data-only applications, these new requirements generally include high bandwidth availability, high packet delivery ratio and low delay rate. Software agents have been demonstrated to provide effective QoS support in networks [6, 7]. Since the mobile nodes act as router as well as host, providing greater autonomy to such nodes becomes the main motivation for using intelligent agents in ad hoc networks. The autonomy, plus the flexibility associated with agents [8] allows the system to meet different QoS requirements as network conditions, eg traffic load [9], change.

2. RELATED WORKS

Recently, a lot of research has been done in QoS based, multi-path and node disjoint routing. Lately, the upcoming concern is the energy issues in mobile ad hoc networks

(MANETs). The recent studies extensively focus on the multipath, discovering extension of the on-demand routing protocols in order to alleviate single-path problems like AODV[6] and DSR[5]. High route discovery latency, Frequent route discovery attempts and possible improvement of data transfer throughput are the parameters which need to be addressed. The AODVM (AODV Multipath) [11], is a multipath extension to AODV. These provide link-disjoint and loop free paths in AODV. Cross-layered multipath AODV (CM-AODV) [12] selects multiple routes on demand, based on the signal-to-interference plus noise ratio (SINR) measured at the physical layer. The Multipath Source Routing (MSR) protocol [13], a multipath extension to DSR, uses weighted round robin packet distribution to improve the delay and throughput. Split Multipath Routing (SMR) [14] is another DSR extension, which selects hop count limited and maximally disjoint multiple routes. Node-Disjoint Multipath Routing (NDMR) [24] provides with node-disjoint multiple paths. Other energy aware multipath protocols which give disjoint paths are Grid-based Energy Aware Node-Disjoint Multipath Routing Algorithm (GEANDMRA) [16], Energy Aware Source Routing (EASR) [17] and Energy Aware Node Disjoint multipath Routing (ENDMR) [18]. The Lifetime-Aware Multipath Optimized Routing (LAMOR) [19] is based on the lifetime of a node which is related to its residual energy and current traffic conditions. Cost-effective Lifetime Prediction based Routing (CLPR) [20], combines cost efficient and lifetime predictions based routing, Minimum Transmission Power Routing (MTPR) [21], and Power-aware Source Routing (PSR) [22].

3. QOS ROUTING CHALLENGES IN MANETS

Because of the inherent properties of MANETs, establishing a stable path which can adhere to the QoS requirement is a challenging issue. The stability issues of a data transmission system in a MANET can be studied under following aspects:

- **Existence of mobile nodes (Mobility factor):** A MANET consists of mobile nodes. Nodes form the network only when they are in the communication range of each other. Link between two nodes is broken if they move out of range. At times, a single link breakage can lead to a major network partitioning. Hence, mobility of the nodes is a major challenging issue for a stable network. Also, breakdown of certain links results in routing decisions to be made again.
- **Limited battery /energy factor:** Mobile nodes are battery driven. Thus, the energy resources for such networks are limited. Also, the battery power of a mobile node depletes not only due to data transmission but also because of interference from the neighboring nodes. Thus, a node loses its energy at a specific rate even if it is not transferring any data packet. Hence the lifetime of a network largely depends on the energy levels of its nodes. Higher the energy level, higher is the link stability and hence, network lifetime and lower is the routing cost.
- **Multiple paths:** To send data from a source to destination, a path has to be found before hand. If a

single path is established, sending all the traffic on it will deplete all the nodes faster. Also, in case of path failure, there will be no alternate path to act as a backup path. Thus, establishing multiple paths aids not only in traffic engineering but also prevents faster network degradation

- **Node-disjoint paths:** Multiple paths between two nodes can be either link-disjoint or node disjoint. Multiple link-disjoint paths may have one node common among more than one path. Thus, traffic load on this node will be much higher than the other nodes of the paths. As a result, this node tends to die much earlier than the other nodes, leading to the paths to break down much earlier. Thus, the presence of node disjoint paths prolongs the network lifetime by reducing the energy depletion rate of a specific node.

4. NODE-DISJOINT MULTIPATH ROUTING PROTOCOL (NDMR)

Node-disjoint multipath routing protocol (NDMR) is a new protocol developed by Xuefei Li [5], modifying and extending AODV to enable the path accumulation feature of DSR in route request packets. It is efficient in discovering multiple paths between source and destination nodes with low broadcast redundancy and minimal routing latency.

In the route discovery process, the source creates a route request packet (RREQ) containing message type, source address, current sequence number of source, destination address, the broadcast ID and route path. Then the source node broadcasts the packet to its neighbouring nodes. The broadcast ID is incremented every time when the source node initiates a RREQ, forming a unique identifier with the source node address for the RREQ.

Finding node-disjoint multiple paths with low overhead is not straightforward when the network topology changes dynamically. NDMR routing computation has three key features that help it to achieve low broadcast redundancy and avoid introducing a broadcast flood in MANETs:

- Path accumulation
- Decreasing multipath broadcast routing packets (using shortest routing hops)
- Selecting node-disjoint paths.

In NDMR, AODV is modified to include path accumulation in RREQ packets. When the packets are broadcast in the network, each intermediate node appends its own address to the RREQ packet. When a RREQ packet finally arrives at its destination, the destination is responsible for judging whether or not the route path is a node-disjoint path. If it is a node-disjoint path, the destination will create a route reply packet (RREP) which contains the node list of whole route path and unicast it back to the source that generated the RREQ packet along the reverse route path. When an intermediate node receives a RREP packet, it updates the routing table and reverse routing table using the node list of the whole route path contained in the RREP packet.

But if all of the duplicate RREQ packets are broadcast, this will generate a broadcast storm and dramatically decrease the performance. In order to avoid this problem, a novel approach is introduced in NDMR which records the shortest routing hops to keep loop-free paths and decrease routing broadcast overhead. When a node receives a RREQ packet for the first time, it checks the node list of the route path, calculates the number of hops from the source node to itself and records the number as the shortest number of hops in its reverse routing table. If the node receives a duplicate RREQ packet again, it computes the number of hops and compare it with the shortest number of hops in its reverse routing table. If the number of hops is larger than the shortest number of hops in the reverse routing table, the RREQ packet is dropped. When receiving a duplicate RREQ, the possibility of finding node-disjoint multiple paths is zero if it is dropped, for it may come from another path. Only when it is less than or equal to the shortest number of hops, the node appends its own address to the node list of the route path in a RREQ packet and broadcasts it to neighbouring nodes again.

The destination node is responsible for selecting and recording multiple node-disjoint paths. When receiving the first RREQ packet, the destination records the list of node IDs of the entire route path in its reverse route table and sends a RREP packet along the reverse route path. When the destination receives a duplicate RREQ, it compares the whole node IDs of the entire route path in the RREQ to all of the existing node-disjoint paths in its reverse routing table. If there is no common node (excepting the source and destination node) between the node IDs from the RREQ and node IDs of any node-disjoint path in the destination's reverse table, the route path in current RREQ is a node-disjoint path and is recorded in the reverse routing table of the destination. Otherwise, the current RREQ is discarded.

Fig. 1 shows a possible result of multiple node-disjoint paths between source node *s* and destination node *d*.

There are three paths between them: route 1 (R1) (*s-c-e-f-d*), route 2 (R2) (*s-a-b-d*) and route 3 (R3) (*s-g-h-i-d*).

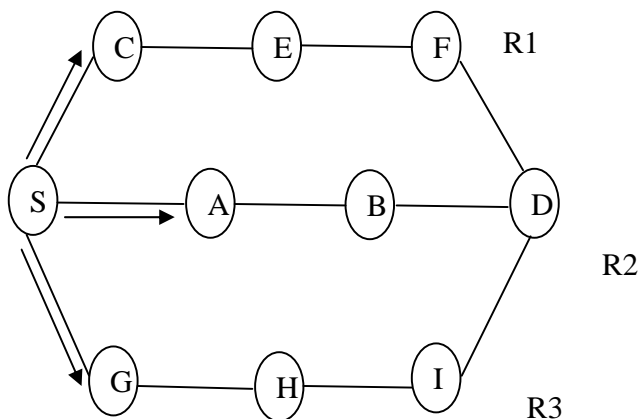

Figure: 1. Multiple node-disjoint paths

5. QUALITY OF SERVICE (QoS) IN NDMR

The concept of QoS is a guarantee by the network to satisfy some preset service performance constraints for the user in terms of the end-to-end delay, available bandwidth, probability of packet loss, and so on [10]. Future ad hoc mobile networks will carry increasing levels of diverse multimedia applications such as voice, video and data. This has resulted in an increased focus on guaranteeing the QoS for such networks eg delay sensitive applications such as voice, as specified to the customer in a Service Level Agreement (SLA). This section introduces a novel approach to QoS in MANETS: QoS enhanced NDMR.

In NDMR, after deciding that a path is a node-disjoint path, the destination will create a route reply packet (RREP) which contains the node list of whole route path and unicasts it back to the source. However, since an RREP currently contains only the route path, it cannot provide effective QoS Support for MANETs. It is proposed that RREP packets should carry more information such as delay time (queue length) in order to meet certain SLA requirements. When each intermediate node receives a RREP packet, it can add the queue length of this node to the "queue_length" field in RREP packet. Thus, when the source node receives the RREP from the destination node it knows the exact queue length along the path.

Each source will keep three node-disjoint paths for a particular destination. With the "queue_length" field in RREP packet, it can choose the path with the minimum queue length. This will allow it to minimise the delay time thus providing higher QoS.

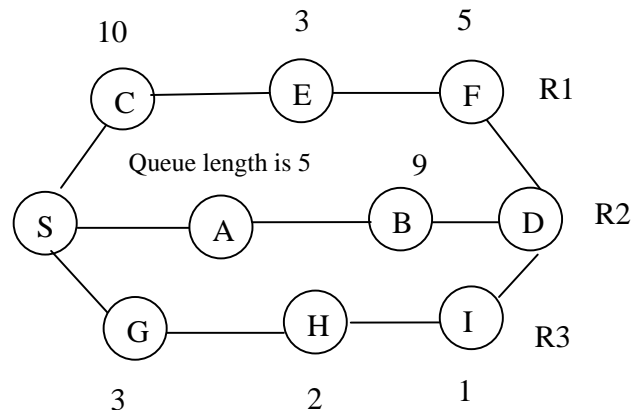

Figure: 2. Queue length in multiple node disjoint paths

Fig. 2 shows queue length along the multiple paths. Assume source node *S* first receives the RREP from route 2 (R2) (*s-a-b-d*). In standard NDMR, *S* will always transmit data on that route so long as no link break happens, even though route 3 (R3) (*s-g-h-i-d*) has a smaller queue length and hence a lower rate of delay. With the introduction of the "queue_length" field in RREP, *S* will initially choose route 2 (R2) (*s-a-b-d*) to transmit data as it receives an RREP from that route first. But after it has received the RREP from route 3 (R3) (*s-g-h-i-d*), it will compare the queue lengths of the existing routes, and then will change to route 3 (R3) (*s-g-h-i-d*) to continue

transmitting data. Using this approach, transmission delay rate can be reduced and the SLA requirements can be met.

As an RREP is generated only in the route discovery process, the protocol cannot frequently refresh the queue length of each path. As part of the enhancement to NDMR, the need for a similar packet, RREU (route update packet) that performs more frequent updates and contains the “queue_length” field used in an RREP packet, has been identified. The destination node will periodically unicast RREU packet containing up-to-date queue length to the source node. The source will be able to choose the best path according to the change of queue length in real time.

6. RESULT & DISCUSSION

The Qualnet network simulator [25] is used to analyze the parametric performance of Node-disjoint Multipath Routing (NDMR) [5] and Quality of Service Enabled NDMR [10] routing protocols. The performance is analyzed with different variation of traffic load. These are applied on different source to destination nodes. The results are shown in figures 3 and 4.

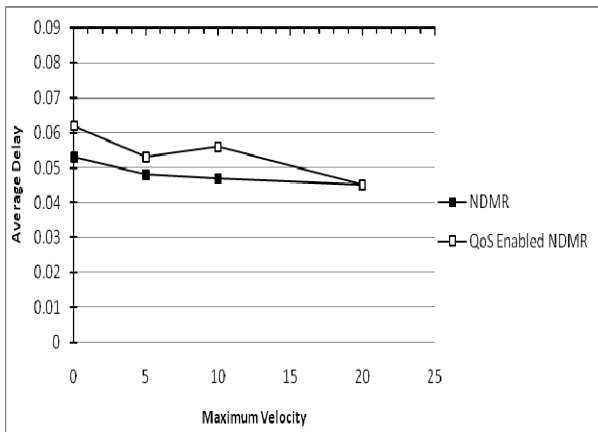

Figure: 3 Average delays

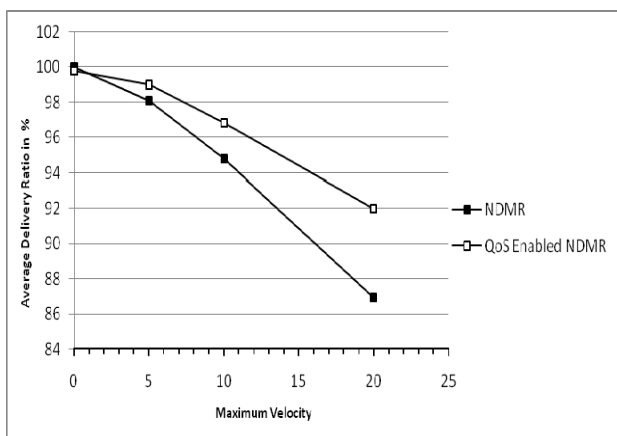

Figure: 4. Packet delivery ratio

Fig. 3 shows that simulation results of packet average delay for QoS enabled NDMR give better performance than that of NDMR. The delay time for all mobile velocities trends to be

equal. The reason is that with RREP packets carrying real-time delay back and route update packets, the data packets will always be transmitted along the lowest congestion path. It can be seen from Fig. 4 that QoS enabled NDMR has a little lower packet delivery ratio than NDMR. The reason is that the introduction of route update packets slightly increases packet collision in the network. Nevertheless, the packet delivery ratio is still above 86% for all mobile velocities.

7. AGENT-BASED SLA MANAGEMENT

A major feature of the QoS enabled NDMR proposed in this paper is the application of intelligent software agents for SLA management. Employing intelligent agents provides greater autonomy to the mobile nodes, allowing for the essential flexibility to respond to the dynamic nature MANETs. This flexibility will allow the system to meet the QoS requirements agreed in SLAs.

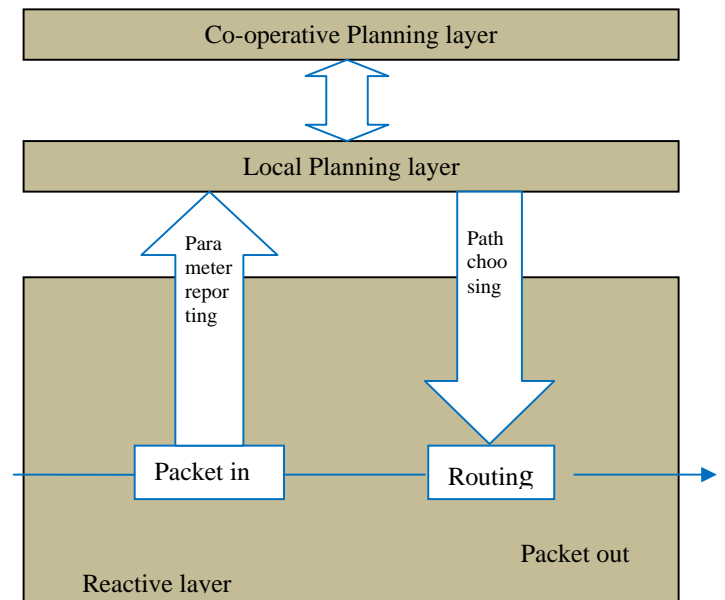

Figure: 5 NDMR agent structure

Queue length and buffer length are very important parameters in queue management and should be taken into consideration to meet the requirements of any SLAs. Considering the importance, these parameters only have been used to calculate the delay time for each path. A technique to keep the queue length short in a long buffer is necessary. It is proposed that this technique be under the control of an intelligent agent.

General agent uses three layers – reactive, local planning and co-operative planning – which allow it to take action and make decisions in different timescales. The reactive layer is designed for quick response in real-time. More complex and slower acting functions are implemented in the two planning layers. Generally the local planning layer is concerned with long-term actions within its own node and the co-operative planning layer is concerned with long-term actions with other

agents. Future work is intended to develop the communication and cooperation with agents in other nodes. In QoS enhanced NDMR, the co-operative planning layer is used for deciding whether to change path or not (according to the queue length of this node and other nodes); the local planning layer is for choosing which path to transmit data (according to the queue length of this node). As illustrated in Fig. 5, the packet is transmitted on the reactive layer and the parameters critical to decision making (such as queue length) are passed up to the planning layers. After calculating delay and choosing the appropriate path, the packet will be routed out along the chosen path.

8. LIMITATIONS OF NDMR

NDMR and QoS enabled NDMR show better performance, but they are all in the scenario with a dense node network – 50 nodes in 1000 m * 1000 m fields. In a different situation of sparse node network with 25 nodes in 1000 m * 1000 m fields, the average delay time of NDMR and QoS NDMR will increase. The main reason is that with the lower number of nodes, the possibility of finding node-disjoint route decrease. For one source and destination pair, there may be only one route.

9. CONCLUSION

This paper has presented architecture for guaranteeing QoS based on Node-Disjoint Multipath Routing Protocol (NDMR) in mobile ad hoc networks. The issue of QoS provision is highly challenging for MANETs and necessarily different from traditional fixed networks. Due to the growth in demand for diverse multimedia applications, fulfilling the QoS guarantees in SLAs, requires solutions that are responsive to network state. The use of multiple node-disjoint paths gives the opportunity for allocating packets to paths in an optimum way to meet instantaneous constraints. This paper has presented a means of developing NDMR – through the queue length field and additional route update packets – to allow QoS measurement along such node-disjoint paths. By using intelligent agents it will be possible to distribute this optimization at the planning layer, to allow very fast processing to occur at the reactive layer while still taking into account the needs of all nodes.

REFERENCES

- [1]. Szu-Lin Su, Yi-Wen Su, Chien-Sheng Chen and Wen-Hsiung Liu "A Novel Design of Node-disjoint Multi-path QoS Routing in Multi-hop Ad Hoc Networks" Proceedings of IEEE 2011.
- [2]. Shunli Ding and Liping Liu "A node-disjoint multipath routing protocol based on AODV" Ninth International Symposium on Distributed Computing and Applications to Business, Engineering and Science, 2010.
- [3]. Charles E. Perkins, Elizabeth M. Belding-Royer, Samir R.Das, Ad Hoc On-Demand Distance Vector (AODV) Routing, <http://www.ietf.org/internetdrafts/draft-ietf-manet-aodv-13.txt>, IETF Internet draft, Feb 2003.
- [4]. J.Broch, D.Johnson, and D. Maltz, The Dynamic Source Protocol for Mobile Ad hoc Networks, <http://www.ietf.org/internet-drafts/draft-ietf-manetsr-10.txt>, IETF Internet draft, 19 July 2004.
- [5]. Xuefei Li and Laurie Cuthbert, On-demand Node-Disjoint Multipath Routing in Wireless Ad hoc Networks, In *Proceedings of the 29th Annual IEEE Conference on Local Computer Networks, LCN 2004*, Tampa, Florida, U.S.A., November 16-18, 2004.
- [6]. Alex Hayzelden & John Bigham Heterogeneous Multi-Agent Architecture for ATM Virtual Path Network Resource Configuration, in *Intelligent Agents for Telecommunications Applications (IATA '98)*, LANAI 1437, S.Albayrak & F.J.Garijo (eds), Springer-Verlag, 1998, ISBN 3-540-64720-1.
- [7]. L.G. Cuthbert, D. Ryan, L. Tokarchuk, J. Bigam and E. Bodanese, Using intelligent agents to manage resource in 3G Networks, *Journal of IBTE*, 2(4), 2001.
- [8]. M.Wooldridge & N.R. Jennings, Agent Theories, Architectures and Languages: a Survey in Wooldridge & Jennings eds. *Intelligent Agents*, Springer-Verlag, Berlin, 1995.
- [9]. Soamsiri Chantaraskul, An Intelligent-Agent Approach for Managing Congestion in W-CDMA Networks, *PhD thesis, University of London*, August 2005.
- [10]. Zhenqiang Ye, Strikanth V. Krishnamurthy and Satish K. Tripathi, "A Framework for Reliable Routing in Mobile Ad Hoc Networks", *IEEE INFOCOM*, 2003.
- [11]. M. K. Marina and S. R. Das, "On-Demand MultiPath Distance Vector Routing in Ad hoc Networks", Proceedings of the Ninth International Conference on Network Protocols (ICNP), IEEE Computer Society Press, 2001, pp. 14-23.
- [12]. J.Park, S.Moht and I.Chung " Multipath AODV Routing Protocol in Mobile Ad Hoc Networks with SINR-Based Route Selection", International Symposium on Wireless Communication Systems, IEEE , 2008, pp:682-688.
- [13]. L.Wang, L.Zhang, Y.Shu and M.Dong," Multipath source routing in wireless ad hoc networks", Proceedings of Canadian Conference on Electrical and Computer Engineering, 2000, Vol 1, pp. 479-483. S. J. Lee and M. Gerla, "Split Multipath Routing with Maximally Disjoint Paths in Ad hoc Networks", Proceedings of the IEEE International Conference on Communications (ICC), 2001, Vol 10, pp. 3201- 3205.
- [14]. Luo Liu and Laurie Cuthbert "QoS in Node-Disjoint Routing for Ad Hoc Networks" ICC Workshops '08. IEEE International Conference on Communications, 2008.
- [15]. W. Zhongyu, D. Xiangjun and C. Lin, " A Grid-Based Energy Aware Node-Disjoint Multipath Routing Algorithm for MANETs", Proceedings of International Conference on Natural Computation, 2007, Vol. 5, pp. 244-248.
- [16]. D.Youn H, K Eui-Hyeok and L. Jae-Sung, " An Energy Aware Source Routing with Disjoint Multipath Selection for Energy- Efficient Multihop Wireless Ad hoc Networks", Proceedings of International Federation for Information Processing, 2006, pp. 41-50.
- [17]. M. Bheemalingaiah, M. M. Naidu, D. Sreenivasa Rao and G. Varaprasad, " Energy Aware Node-Disjoint Routing in Mobile Ad Hoc Networks", Journal of Theoretical and Applied Information Technology, 2009, pp 416-431.
- [18]. T. Liansheng, X Ling, T.K King, M.Lei and Zukennan, "LAMOR: Lifetime-Aware Multipath Optimized Routing Algorithm for Video Transmission over Ad hoc Networks", Proceedings of IEEE Vehicular Technology Conference, 2006, Vol. 2, pp. 623-627.
- [19]. W.Su, S.Ju Lee and M.Gerla , " Mobility Prediction in Wireless Networks". MILCOM 2000, Vol 1, pp.491-495.
- [20]. M. K. Marina and S. R. Das, "On-Demand MultiPath Distance Vector Routing in Ad hoc Networks", Proceedings of the Ninth International Conference on Network Protocols (ICNP), IEEE Computer Society Press, 2001, pp. 14-23.
- [21]. M. Maleki, K. Dantu and M. Pedram, "Power-aware source routing protocol for mobile ad hoc networks", Proceedings of the IEEE international symposium on low power electronics and design, 2002, pp.72-75.
- [22]. D.Kim, Garcia-Luna-Aceves, J.J. Obraczka, K. Cano and J.-C. Manzoni, "Routing mechanisms for Mobile Ad hoc Networks Based on Energy Drain Rate", Mobile Computing, Vo12, 2003, pp 161- 173.
- [23]. X.Li, Ph.D thesis on "Multipath Routing and QoS Provisioning in Mobile Ad hoc Networks", Queen Mary University of London, 2006.
- [24]. Qualnet Simulator www.scalable-networks.com