

Geo-Spatial Assessment of Water Quality in Shigar Valley, Gilgit Baltistan, Pakistan

Syeda Urooj Fatima¹, Moazzam Ali Khan^{1*}, Syed Shahid Shaukat¹,
Aamir Alamgir¹, Farhan Siddiqui², Nasir Sulman³

¹Institute of Environmental Studies, University of Karachi, Karachi, Pakistan

²Department of Computer Science, University of Karachi, Karachi, Pakistan

³Department of Special Education, University of Karachi, Karachi, Pakistan

Email: *sherwanis@hotmail.com, *moazzam@uok.edu.pk

How to cite this paper: Fatima, S.U., Khan, M.A., Shaukat, S.S., Alamgir, A., Siddiqui, F. and Sulman, N. (2022) Geo-Spatial Assessment of Water Quality in Shigar Valley, Gilgit Baltistan, Pakistan. *Health*, 14, 535-552.

<https://doi.org/10.4236/health.2022.145040>

Received: March 28, 2022

Accepted: May 17, 2022

Published: May 20, 2022

Copyright © 2022 by author(s) and Scientific Research Publishing Inc.

This work is licensed under the Creative Commons Attribution International License (CC BY 4.0).

<http://creativecommons.org/licenses/by/4.0/>



Open Access

Abstract

The current study attempted to evaluate the water quality in terms of physico-chemical properties, metals, and bacteriological characteristics of the surface water available in Shigar Valley located along Shigar River in sub-district Shigar of district Skardu, Gilgit Baltistan (GB), Pakistan. A total of 17 water samples were collected during 2020 and analysed to perform multivariate analysis through principal component analysis (PCA) and cluster analysis (CA). Spatial distribution using inverse distance weight (IDW) interpolation was also utilised to determine the water quality in the valley to elucidate public health concerns. The study reveals that physico-chemical characteristics are the most important that affect water quality, followed by metals and bacteriological variables, according to a PCA application based on multivariate analysis. Examinations found that some of the metals including arsenic (As), copper (Cu), lead (Pb), iron (Fe), zinc (Zn), manganese (Mn), and molybdenum (Mo) and all bacteriological parameters enlisting total coliform count (TCC), total faecal coliform (TFC), and total faecal streptococci (TFS) are not following the WHO guidelines that could be hazardous from the public health viewpoint. The IDW-based spatial distribution indicates that water samples have an intermittent and unusual distribution of observed parameters. Having considerable community settlements, people in the valley have limited options and have no choice except to consume the available water as no alternate source is available. People hardly question the water quality and rarely examine the water potability. The study also demonstrated that combining PCA with IDW would be a powerful method for assessing water quality. It is suggested that the sources of contamination be investigated further in detail to reduce the pollution load of the surface water in the valley, which could aid in the development of sustainable ecotourism.

Keywords

Shigar Valley, Physico-Chemical, Metals, Microbial, PCA, IDW

1. Introduction

Water is essential for life and an important parameter to determine the public health quality [1] and its monitoring is necessary for better water resources conservation [2]. However, the quality of drinking water in developing countries is generally poor, especially in remote areas, and is a major source of a variety of water-borne diseases [3]. As a result, it's critical to examine and monitor the water quality of available water resources, especially those that are predominantly used for drinking [4].

Across Pakistan, geospatial assessment of drinking water quality has been conducted in multiple geographic areas including Khyber Pakhtun Khwa (KPK) [5], Punjab [6], and Sindh [7]. Similarly, water quality in Gilgit Baltistan (GB) has been assessed in various valleys and cities [8] and in Skardu springs [9] [10], and Basho Valley [11]; however, studies comprising geospatial assessment [12] and statistical analysis can be rarely found in GB.

Findings from a study conducted in KPK [5] revealed that the sodium and chlorides concentration in water samples was not following the WHO guidelines and therefore unsuitable for potable use. A study from Punjab [6] in the lower Jhelum canal area showed that concentrations of observed parameters were within permissible limits of WHO and NEQS guidelines except for *E. coli*. Water quality reported in the Nagarparkar area of Sindh [7] found that the majority of the analysed samples are exceeding the thresholds mentioned by WHO and the region is prone to the spread of water-borne diseases. However, a study conducted in Nagar Valley of GB [8] reported that drinking water in some villages of the valley is free from faecal contamination and was well within the approved standards set by WHO and EPA. Studies on Skardu springs' water quality [9] [10] reported that concentrations of the physico-chemical, microbial, and metals are within the safer limits of drinking water as prescribed by the Pak-EPA and WHO and found suitable for bathing and other body contact activities. However, a study conducted in Basho Valley [11] reported that water quality is satisfactory in terms of physico-chemical characteristics but not in terms of metals and bacteriological profile.

This study has attempted to monitor the water quality of Shigar Valley which is located along the Shigar River in the Skardu district of Gilgit Baltistan. The goal of this study was to reveal the principal causes of contamination in the valley's drinking water. The discourse is made through advanced statistical and geographical tools to perform the analysis. The study also contributes to the achievement of SDG 6: Clean Water and Sanitation by issuing a call of action for improved water quality in Pakistan's remote and northern areas, where water supplies are a major threat to public health.

2. Methodology

2.1. Study Area

Shigar Valley is located in District Shigar of Gilgit Baltistan and stretches from 35°29'14.24"N and 75°41'56.59"E to 35°23'54.36"N and 75°44'57.84" E along Shigar River. *Skoro Lungma* and *Bauma-harel Lungma* tributaries originating from the Shigar River also bypass the valley providing a flourished water supply network. A number of settlements comprising small populated villages are located in the valley, economically depending on the agricultural and livestock. These villages include Skoro, Sankhor, Namika, Qasimabad and Hasnainabad.

The valley lies in the Karakoram mountains range area [10] and is accessible by Shigar Valley Road which connects this region with Gilgit-Skardu road and nearby regions. The valley experiences long winters and very short summer seasons which provides only a limited time span for the growth of agricultural crops [13]. The community of this region strongly followed traditional Balti culture, particularly in housing infrastructure, agricultural and farming practices, cooking, dressing and sports [14].

2.2. Water Sampling

In 2020, 17 water samples from Shigar Valley were gathered deterministically using a random sampling approach (Figure 1). Water samples were collected from drinking water sources which are regularly consumed by human settlements in the valley and on the basis of site accessibility throughout the valley. The samples were collected and stored in sanitised glass bottles in an icebox before being transported to the Institute of Environmental Studies at the University of Karachi.

2.3. Physico-Chemical Analysis

The pH, turbidity, salinity, and total dissolved solids (TDS) were determined on site. Turbidity in the water samples was measured using a EUTECH meter (Model No. TN-100) while HACH sensation 156 multi-parameter dissolved oxygen meter was used to measure pH and salinity. Gravimetric and argentometric methods of estimation were employed for TDS and chloride [15]. Sulphate was ascertained by the gravimetric method while hardness was determined by EDTA titrimetric method. For nitrate and total phosphate, brucine-reagent and ascorbic acid methods were employed respectively. Standard Methods for the Examination of Water and Wastewater were used for the analysis of the above-mentioned parameters [15].

2.4. Metal Analysis

For analysis of metals, appropriate Merck NOVA 60-Germany kits were used to estimate arsenic (As), copper (Cu), lead (Pb), iron (Fe), zinc (Zn), calcium (Ca), magnesium (Mg), manganese (Mn), fluorine (inorganic form, fluoride, F⁻), and molybdenum (Mo).

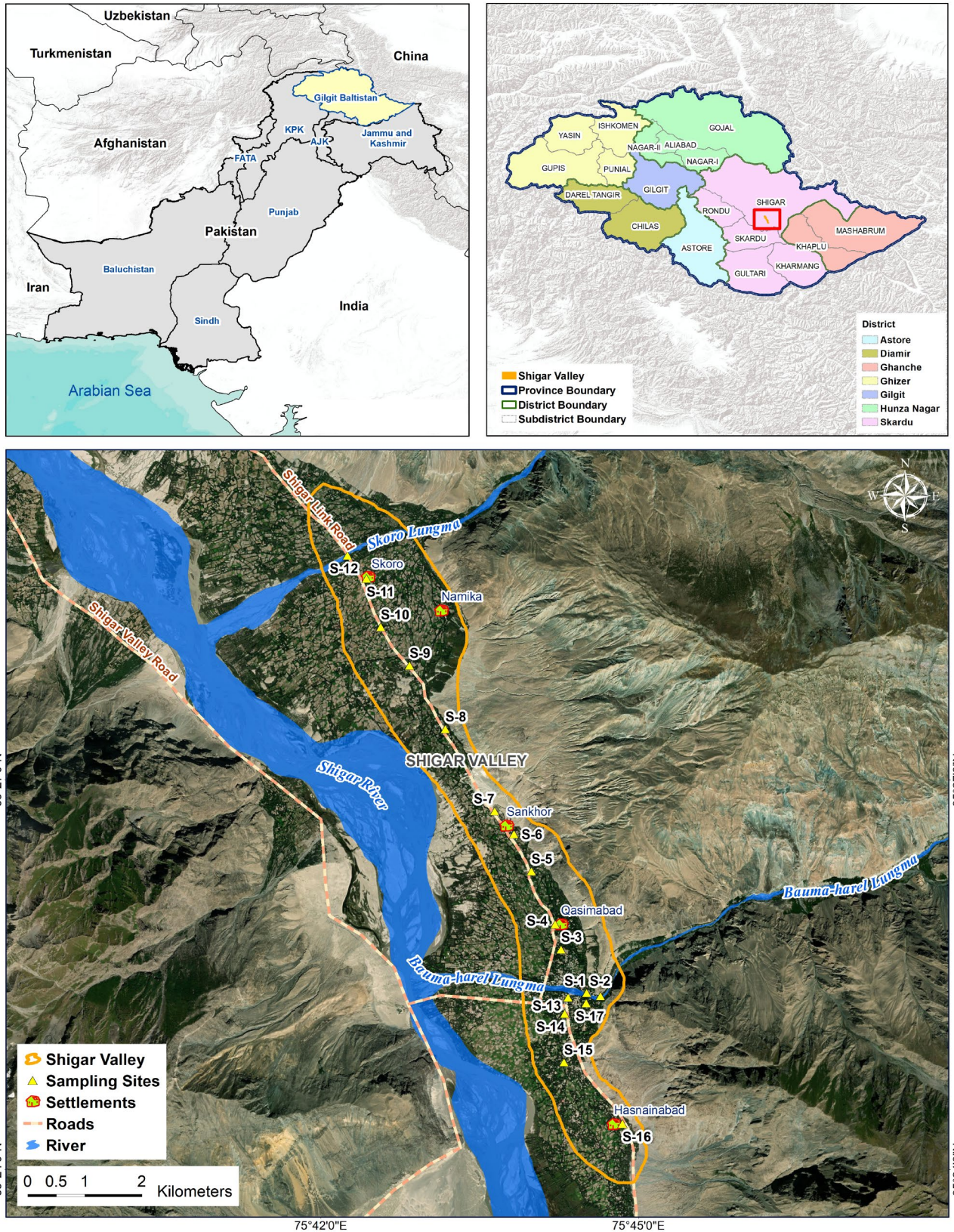

Figure 1. Study area (Shigar Valley).

2.5. Bacteriological Analysis

The bacteriological parameters were examined in the water samples including total coliforms count (TCC), total faecal coliforms (TFC) and total fecal streptococci (TFS). Single and double strength lactose broth (Merck, Germany) was used for TCC while EC medium (Merck, Germany) was used for the determination of TFC. TFS was estimated by using sodium azide broth [16]. The most probable number (MPN) technique was employed to determine the bacterial load in the water samples [15].

2.6. Descriptive Statistics

The arithmetic mean, skewness, and kurtosis were used as descriptive statistics for the above-mentioned parameters [17]. The results of descriptive statistics were obtained using SPSS v22 [18].

2.7. Multivariate Analysis

PCA is a widely used multivariate analysis method that calculates the dynamics of all observed parameters for a system with the goal of reducing the dimensionality of multivariate data by giving meaningful information in small components. All of the system's usual characteristics are represented in the primary components ultimately resulting [19] [20].

As a result, PCA is used for the acquired findings in order to obtain relevant information about the water quality available in Shigar Valley and to examine the most affecting water quality characteristics and their relationships. On the water quality data, PCA was used, followed by cluster analysis using unweighted pair group ordination and the Euclidean distance [21] [22]. To get the original data matrix, a number of algorithms were used (Equation (1)), standardized data after dimensionality reduction (Equation (2)), correlation coefficient matrix (Equation (3)), eigenvalues and eigenvectors (Equation (4)) and finally the principal components (Equation (5)), as shown below:

$$x = (x_{ij})_{n \times p} = \begin{vmatrix} x_{11} & \dots & x_{1p} \\ \vdots & \ddots & \vdots \\ x_{n1} & \dots & x_{np} \end{vmatrix} \quad (1)$$

$$x_{ij}^* = \frac{x_{ij} - \bar{x}_j}{s_j} \quad (2)$$

$$r = (r_{ij})_{p \times p} = \frac{1}{n-1} \sum_{i=1}^n x_{ii}^* * x_{ij}^* \quad (3)$$

$$F_i = u_{i1}x_1^* + u_{i2}x_2^* + \dots + u_{in}x_n^* \quad (i = 1, 2, \dots, n) \quad (4)$$

$$F = \frac{\lambda_1}{\lambda_1 + \lambda_2 + \dots + \lambda_n} F_1 + \frac{\lambda_2}{\lambda_1 + \lambda_2 + \dots + \lambda_n} F_2 + \dots + \frac{\lambda_n}{\lambda_1 + \lambda_2 + \dots + \lambda_n} F_n \quad (5)$$

where n and p are the numbers of sampling sites and water quality parameters, respectively; x_{ij} and x_{ij}^* are originally measured data and standardized varia-

ble, respectively; x_i^* is the standardized indicator variable; \bar{x}_j is the average value for j^{th} indicator; s_j is the standard deviation of j^{th} indicator; r is the correlation coefficient; F_i is the principal component; and λ_i and u_i are eigenvalues and eigenvectors, respectively. All statistical analysis results were obtained using SPSS [23], OriginPro [24] and RStudio [25] environment.

2.8. Spatial Distribution by Inverse Distance Weight (IDW)

Spatial distribution methods for water quality mapping by interpolation assist in determining the values of unknown (unsampled) points using weighted measurements and proximity focused assumptions that nearby points are more alike than points located comparatively far away. Kriging and Inverse Distance Weight are the most often used interpolation algorithms based on geostatistical approaches (IDW). Kriging is divided into three types: simple, ordinary, and universal kriging, and it entails applying weights to known or measured values based on the spatial orientation of the measured places [26]. Unlike Kriging, IDW relies solely on the proximity of known (sampled) points, based on the notion that closer sample points have a stronger influence on the unsampled position when linear-weighted combinations are applied [27] [28]. Therefore, IDW is performed for this study using Equations (6) and (7).

$$z = \frac{\sum_{i=1}^n w_i z_i}{\sum_{i=1}^n w_i} \quad (6)$$

$$w_i = \frac{1}{d_i^p} \quad (7)$$

where z is the unknown value for interpolation; z_i is i^{th} data value of sampled location; n is the number of sampling points; w_i is the weight; d_i is the horizontal distance between the observed and interpolation points; and p is the power of distance. ArcMap 10.8.1 [29] *Interpolation* tool from ArcToolbox was used to perform IDW analysis for all parameters.

3. Results and Discussion

This work used statistical and geographic tools such as PCA and IDW interpolation to analyse water quality in Shigar Valley based on physico-chemical, metals, and microbiological factors. The descriptive statistics of all parameters are presented in **Table 1** along with WHO Guidelines [30].

3.1. Water Quality Status

The results of the physico-chemical parameters of the water samples were within the prescribed WHO guidelines (**Table 1**). The mean pH value of the water samples was 7.0 - 7.3 (7.135). Similarly, water quality studies on other areas located near the Shigar Valley such as Basho Valley also reported a mean value of pH as 7.135 ranging from 7.0 - 7.3 which depicted that the water is slightly alkaline in the region [11]. Turbidity was found within the range of 0.09 - 0.38 NTU

Table 1. Descriptive Statistics of 17 water samples from Shigar Valley.

Parameters	Unit	Min	Max	Mean	Std. error	Skewness	Kurtosis	WHO Guideline 2011
Physico-chemical								
pH	-	7.0	7.3	7.135	0.023	0.224	-0.541	6.5 - 8.5
Turbidity	NTU	0.09	0.38	0.216	0.020	0.480	-0.342	<5
Salinity	‰	0.14	0.36	0.232	0.014	0.547	0.277	1.2
Total Dissolved Solids (TDS)		287	415	355.059	9.353	-0.298	-0.997	<1000
Chloride		98.5	140	113.835	2.725	0.658	0.123	<250
Hardness	mg/L	114	169	135.353	4.086	0.460	-0.794	<500
Sulphate (SO ₄ ⁻)		77.8	142	109.065	5.537	0.255	-1.337	250
Nitrate (NO ₃ ⁻)		0.07	0.44	0.188	0.024	1.358	1.565	12
Phosphate (PO ₄ ⁻)		0.56	1.63	1.084	0.069	0.056	-0.187	3
Metals								
Arsenic (As)		BDL	0.074	0.039*	0.006	0.010	-0.931	0.01
Copper (Cu)		0.32	0.91	0.608*	0.045	0.210	-1.212	0.2
Lead (Pb)		0.18	0.96	0.554*	0.057	0.124	-1.008	<0.01
Iron (Fe)		0.24	1.88	1.080*	0.152	0.170	-1.792	0.3
Zinc (Zn)		0.55	1.88	1.352*	0.117	-0.328	-1.616	0.5
Calcium (Ca)	mg/L	25.43	35.71	30.869	0.723	-0.025	-0.957	150
Magnesium (Mg)		6.18	8.67	7.496	0.175	-0.021	-0.956	100
Manganese (Mn)		2.11	3.85	3.079*	0.125	-0.227	-0.973	<0.5
Fluoride (F)		0.028	0.091	0.064	0.004	-0.383	-0.548	1.5
Molybdenum (Mo)		0.11	0.26	0.171*	0.011	0.376	-0.448	0.01
Microbial								
Total Coliform Count (TCC)		<3	460	172.353*	35.338	0.540	-0.026	0
Total Faecal Coliform (TFC)	MPN/100mL	<3	240	77.765*	18.716	0.743	-0.436	0
Total Faecal Streptococci (TFS)		<3	9	4.882*	0.600	0.828	-1.128	0

*Mean values are above WHO Guidelines [30].

(0.216 ± 0.02 NTU) indicates that the results of the turbidity were insignificant as compared to the WHO guidelines (<5 NTU). The results of the turbidity values are lesser than those found in the Basho Valley (0.48 ± 0.15) [11] but in accordance with the previous studies of the nearby areas [31]. The observed water

samples contain salt ranging from 0.14‰ - 0.36‰ with a mean value of $0.232 \pm 0.01\%$ is in compliance with the WHO guideline limit (1.2‰). However, this value is relatively higher as compared to the water samples of the Gilgit city (0.015‰ - 0.025‰) [31] and lesser than Basho Valley (0.29‰) [11]. Observed TDS values are also found within WHO prescribed limit ranging from 285 - 415 mg/L (335.059 ± 9.353 mg/L) but comparatively higher than TDS levels reported in Basho Valley (254.0 ± 37.95 mg/L) [11] and Nagar Valley of District Hunza during 2013 (175.7 - 233.67 mg/L) [8]. Other studies have also reported a lower mean value of TDS such as 104.8 mg/L and 284.4 mg/L [32] in water samples of GB region. Chloride in the water samples of Shigar Valley was found in the range of 98.5 to 149 mg/L with a mean value of 113.835 ± 9.353 mg/L. The concentration of hardness as CaCO_3 was in the range of 114 to 169 mg/L having a mean concentration of 135.353 ± 4.086 mg/L. Studies conducted in Nagar Valley [8], Basho Valley [11], and Danyore Valley [31] of GB also reported calcium hardness and total hardness range from 4.66 - 16.66 mg/L, 83 - 131 mg/L and 160 - 190 mg/L, respectively. The concentration of nitrate and sulphate was in the range of 0.07 - 0.44 mg/L and 77.8 - 142 mg/L having a mean value of 0.188 ± 0.024 mg/L and 109.065 ± 5.537 mg/L, respectively. Phosphate was also detected in the range of 0.56 - 1.63 mg/L corresponding to a mean value of 1.084 ± 0.069 mg/L which is comparatively higher than the mean value of total phosphorus (0.0483 mg/L) reported in a recent study of GB region [33] but lesser than the phosphate found in the water samples of Basho Valley (1.14 mg/L) [11].

The trend of mean metals concentration observed in the water samples of Shigar Valley was $\text{Ca} > \text{Mg} > \text{Mn} > \text{Zn} > \text{Fe} > \text{Cu} > \text{Pb} > \text{Mo} > \text{Fl} > \text{As}$. Among metals, only Calcium, Magnesium and Fluoride were detected within WHO guidelines limit (Table 1). However, results revealed that other metals, including heavy metals, are found in much higher concentrations as compared to WHO guidelines [30]. These results are similar to other previous studies [34] [35] [36]. The continuous uptake of these heavy metals through the use of drinking water is a potential threat to the public health [11].

Results showed that all the water samples obtained from the Shigar Valley are heavily contaminated in terms of bacteriological parameters (>3 MPN/100mL) indicating the presence of organisms of public health concerns as shown in Table 1.

The major sources of these bacteriological parameters are the direct and indirect faecal contamination caused by the domestic sources in the surface water of the valley [8] [33] [37]. It is evident that surface water and sewerage water infrastructure is least developed in the Shigar Valley representing no facility for water and wastewater treatment [11]. The indication of bacteriological pollution is a major threat for water borne diseases in the valley communities. Moreover, it is evident that water resources are not protected by any means.

3.2. Principal Component Analysis (PCA)

After data standardization and performance of normality tests, the results were

analysed by PCA in order to reduce the dimensionality in the data and to find the most influencing factors which alter the water quality of the Shigar Valley. The results of PCA indicate that the influence of parameters can be described by five principal components however; the first three are the most significant ones having eigenvalues 9.131, 3.265 and 2.431 respectively. The first component governs almost 41.504% of the total variance followed by 14.841% and 11.051% of the variance for the second and third component, respectively (**Table 2**).

The results of variable loadings show that the first component is principally accounted for the physico-chemical parameters and metals enlisting salinity, TDS, chloride, hardness, sulphate nitrate, arsenic, copper, lead, iron, zinc, calcium and magnesium. Contrary to it, the second principal component governs the pH and microbial parameters including TCC, TFC and TFS while the third principal component predominantly deals with manganese and fluoride. It was observed that turbidity and phosphate have a major influence on the fourth principal component and pH and molybdenum have also shown the influence as the fifth principal component. Comparatively, the contribution of the parameters involved in the fourth and fifth components is not much influencing as that of the first principal component (**Figure 2**).

Table 2. Principal components.

Principal Components	Eigenvalues	Percentage of Variance (%)
PC1	9.131	41.504
PC2	3.265	14.841
PC3	2.431	11.050
PC4	1.959	8.906
PC5	1.410	6.409

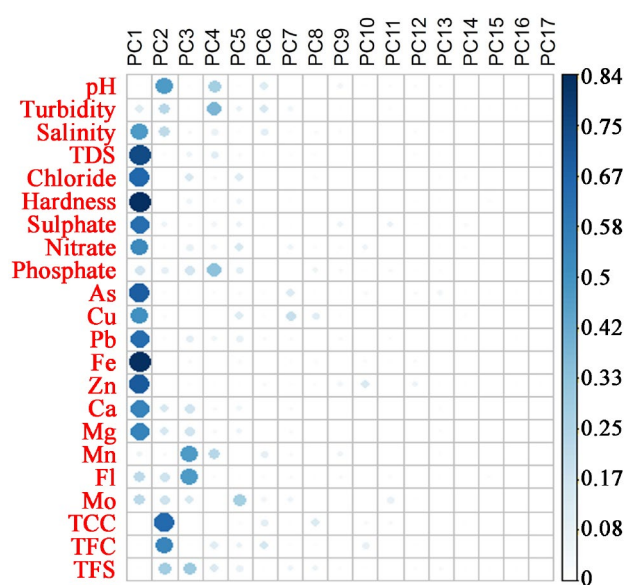

Figure 2. Variable loadings in principal components.

3.3. Cluster Analysis

The cluster analysis was performed to observe the individual sample on the basis of its location. As divided into two groups (Group A and B), most of the sampling locations fall within Group B, whereas Group A only comprises a few sampling sites. It was observed that B2 is the largest subgroup comprising most of the sampling locations. It indicates that the sampling points located in the southern part of valley are highly ordinated with each other having similar characteristics (Figure 3). These sites represent the major amalgam of human settlements.

3.4. Correlation Analysis

The correlation analysis was also separately performed for physico-chemical, metal and microbial parameters. The correlation among physico-chemical parameters showed that salinity, TDS, chloride, and hardness are positively correlated with each other; however, nitrate has shown a negative trend with other physico-chemical parameters. The highest positive correlation was observed between chloride and hardness ($r = 0.86$) (Figure 4). Among metals, the highest positive correlation ($r = 1.00$) was observed between Calcium and Magnesium followed by lead and iron ($r = 0.76$) while the rest of the metals do not show a significant correlation among them (Figure 5). All microbial parameters have shown a strong positive correlation among themselves (Figure 6).

3.5. Spatial Distribution

The IDW-based interpolation for the spatial distribution of the physico-chemical, metals and microbial parameters found in the Shigar Valley water samples showed

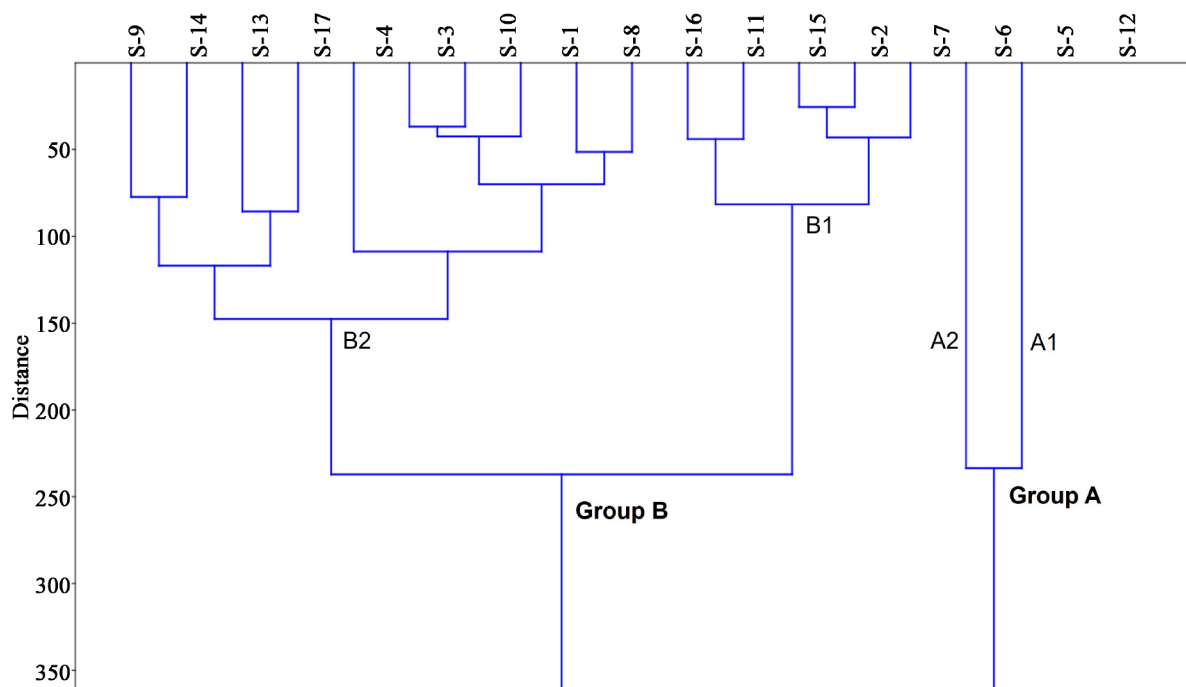

Figure 3. Dendrogram derived from unweighted pair group ordination using the Euclidean distance.

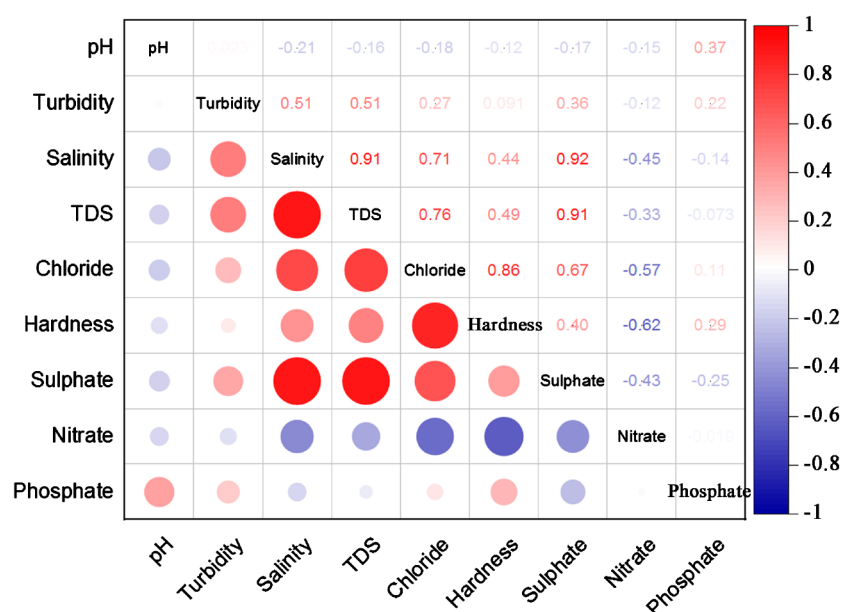

Figure 4. Correlation among physico-chemical parameters in Shigar Valley water samples.

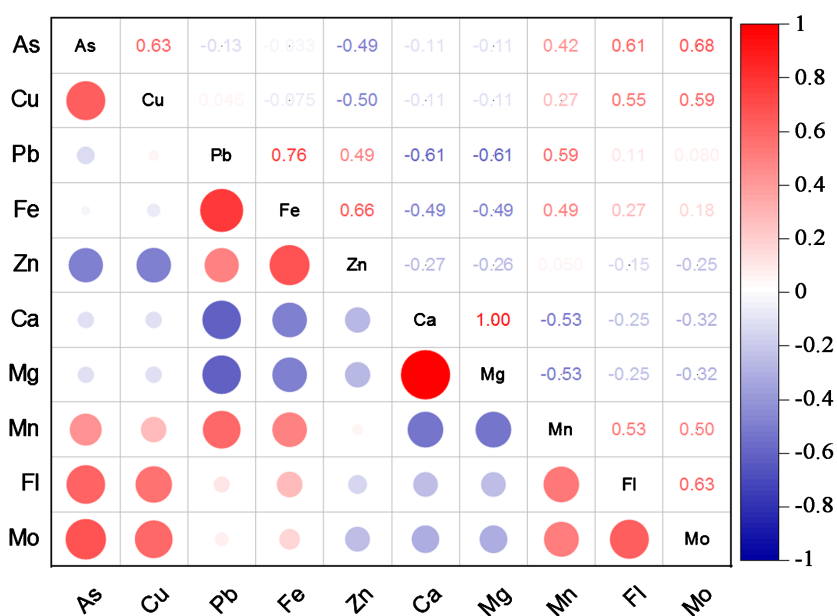

Figure 5. Correlation among metals in Shigar Valley water samples.

a non-uniform pattern throughout the valley. Higher pH and values are detected in the northern and central parts of the Shigar Valley whereas turbidity is high in the water samples collected from central areas of the valley. A similar pattern of spatial distribution is observed for salinity. Whereas, TDS, chloride, hardness phosphate and sulphate are found in elevated concentration in northern and lower areas of the valley (Figure 7). Among metals, Arsenic, Copper and Lead are spatially distributed in the southern part of the valley in very high concentrations. Comparatively, higher concentrations of iron, zinc, Magnesium and Fluoride are only confined to central parts of the valley (Figure 8). It was observed

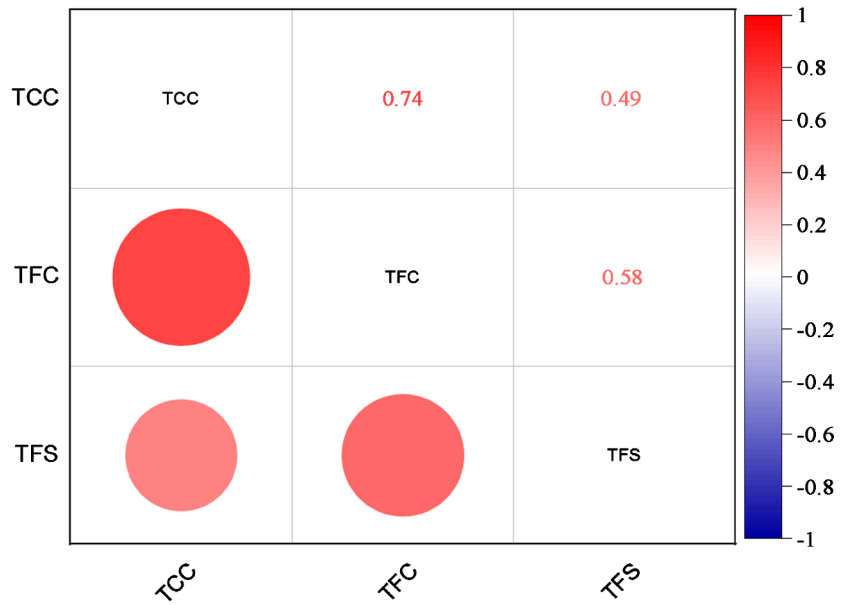

Figure 6. Correlation among microbial parameters in Shigar Valley water samples.

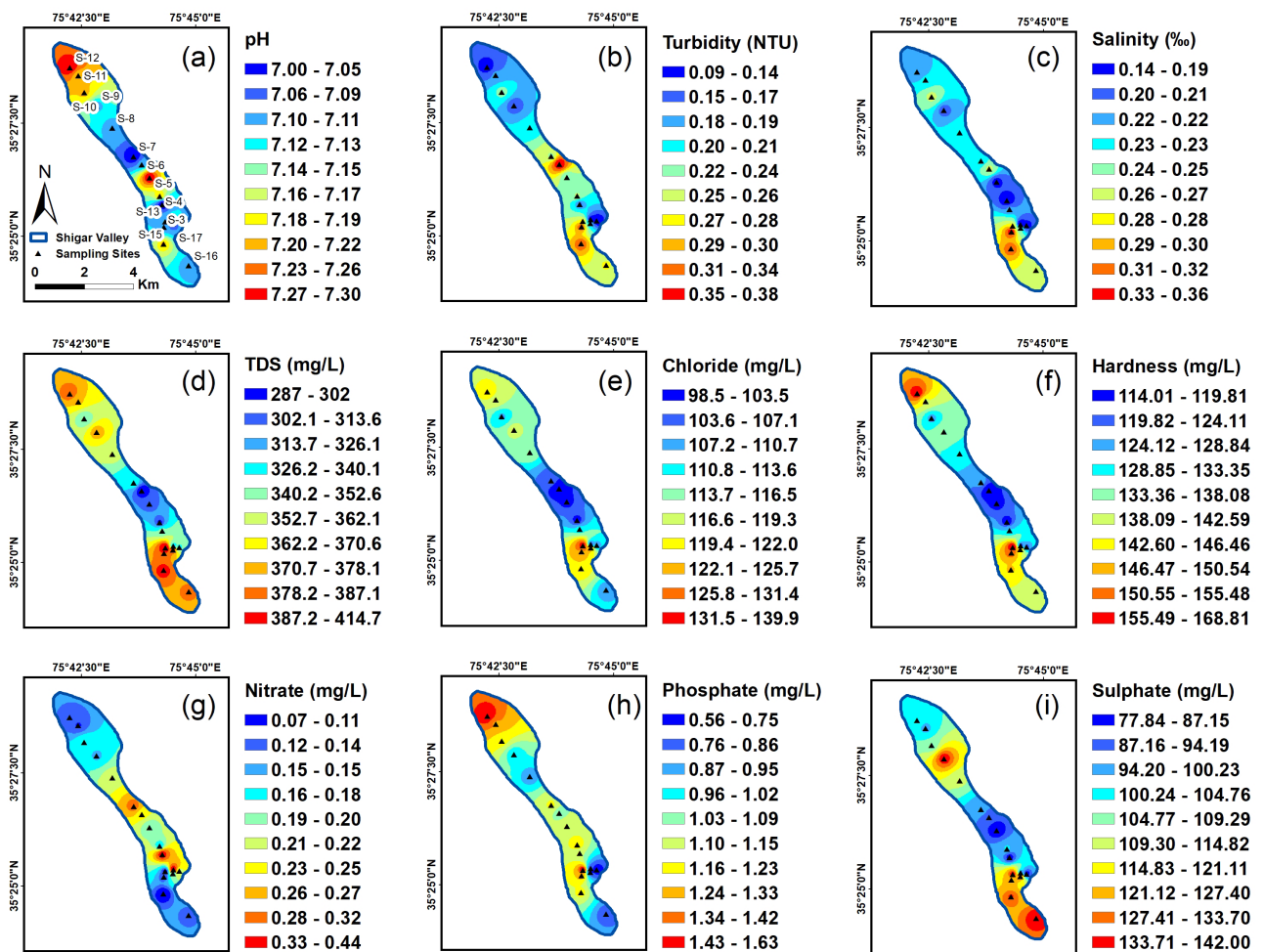

Figure 7. IDW-based spatial distribution of physico-chemical parameters (a) pH; (b) Turbidity; (c) Salinity; (d) Total Dissolved Solids (TDS); (e) Chlorides; (f) Hardness; (g) Nitrate (NO_3^-); (h) Phosphate (PO_4^-); and (i) Sulphate (SO_4^-) in Shigar Valley water samples.

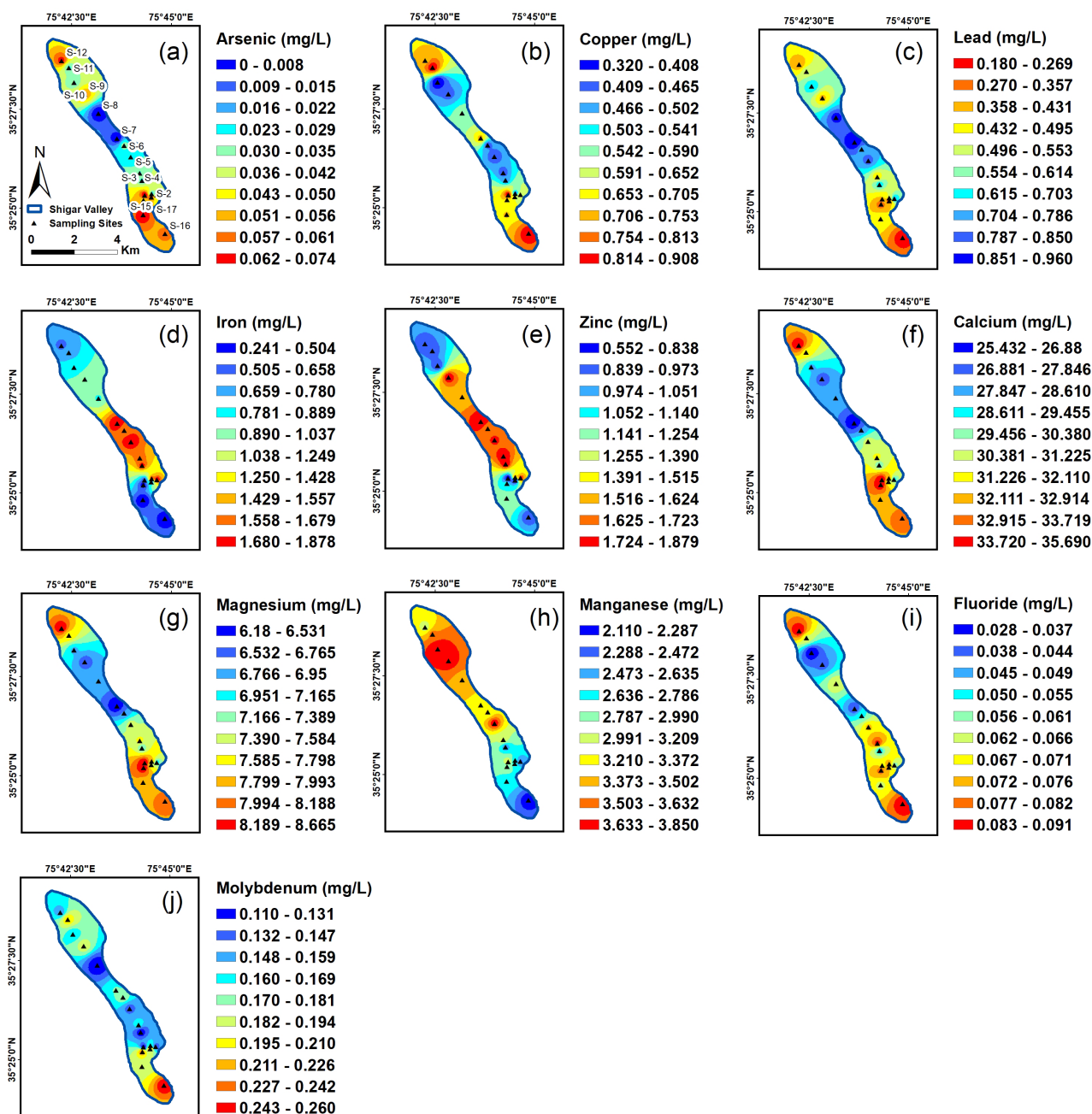

Figure 8. IDW-based spatial distribution of metals (a) Arsenic (As); (b) Copper (Cu); (c) Lead (Pb); (d) Iron (Fe); (e) Zinc (Zn); (f) Calcium (Ca); (g) Magnesium (Mg); (h) Manganese (Mn); and (i) Fluoride (F⁻); and (j) Molybdenum (Mo) in Shigar Valley water samples.

that the northern part of the valley is contaminated in terms of microbial contamination. Almost all the sampling sites are highly contaminated which is an alarming situation for the public health (Figure 9).

3.6. Sources of Contamination and Public Health Concerns

As far as a public health concern is appraised, the health impacts of each parameter should be determined in comparison with the WHO guidelines [30]. The water quality of the Shigar Valley is satisfactory in terms of physico-chemical

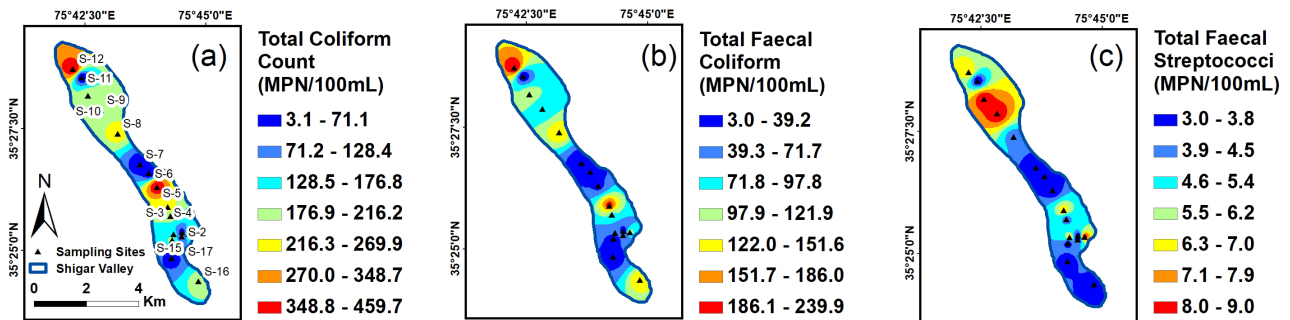

Figure 9. IDW based spatial distribution of microbial parameters (a) Total Coliform Count (TCC); (b) Total Faecal Coliform (TFC) Count; and (c) Total Faecal Streptococci (TFS) in Shigar Valley water samples.

features, as evident by the results, with mean values of all parameters falling within the WHO recommended limit. As a result, no health risks are expected as a result of physico-chemical characteristics. However, constant monitoring is necessary to treat the contamination problem as and when desired.

In contrast, the mean values of Arsenic (0.039 mg/L), Copper (0.608 mg/L), Lead (0.554 mg/L), Iron (1.080 mg/L), Zinc (1.352 mg/L), Manganese (3.079 mg/L) and Molybdenum (0.171 mg/L) are not within the permissible WHO recommended threshold levels (0.01 for Arsenic, 0.2 mg/L for Copper, <0.01 mg/L for Lead, 0.3 mg/L for Iron, 0.5 mg/L for Zinc, <0.05 mg/L for Manganese, and 0.01 mg/L for Molybdenum, respectively) in the water samples of the valley. Due to documented health effects from ingestion as a source of food, drinking, or skin contact, increased quantities of certain metals are likely to cause health concerns. Metal contamination can occur due to natural processes such as natural weathering of rocks, as the source of water is usually surface and river water available in the area, including Shigar River and its minor tributaries [38] and anthropogenic sources, such as residential activities, transportation-related air pollution, and other sources [34]. As a result, consuming contaminated drinking water containing metals, notably heavy metals, can be hazardous to public health, with neurotoxic, carcinogenic, and cardiovascular repercussions [39]. The effects of excessive metal concentrations on human health are well understood, and numerous studies have documented the negative effects on humans. Copper poisoning from drinking water can result in anaemia, liver failure, and renal problems [40] while lead poisoning can cause learning disabilities, memory loss, and nervous system damage. Slight variations in exposure to certain trace and important metals, such as Zinc and Manganese, may cause psychological effects [41] and neurological disorders [42], respectively. Anorexia, joint pain, tremor, and loss of appetite have all been linked to long-term exposure to high Molybdenum concentrations [43].

All of the water samples taken from the Shigar Valley were confirmed to be contaminated with organisms of public health concern. The lack of sewerage infrastructure in the valley is the primary cause of this problem. Furthermore, there is no water treatment facility. Similarly, there is no mechanism in place to check the water quality. Domestic solid waste, in essence, is a possible source of high

bacteriological load in the valley's water supply. Domestic solid waste is typically processed in soak pits before being discharged into open fields without discrimination. This is a problem that affects the entire Gilgit Baltistan region. Moreover, livestock in the valley is also using similar water sources. In addition, the current climate change scenario, which includes rising high temperatures and more violent heat waves, is contributing to the spread of infectious diseases [44].

Considering the challenging terrain of the region, the limitations faced during the study were mainly the site accessibility, weather conditions and lack of prior research studies on the water quality of the valley. Therefore, the conclusions drawn are based on one-time water sampling conducted mainly from the easily accessible areas and human settlements in the Shigar Valley.

4. Conclusions

The study highlights the water quality of Shigar Valley from three perspectives: 1) the water quality is satisfactory on the basis of physico-chemical characteristics, 2) heavy metals are present in the high concentration making the water quality unsuitable for drinking purposes, and 3) on the basis of bacteriological load, the drinking water available in the area is highly unsuitable and can be a potential source of health risk for the public.

Although the water's physico-chemical qualities are good, principal component analysis (PCA) computation reveals that the influence of a few physico-chemical parameters is the greatest, making it a critical factor in determining the valley's overall water quality. Interpolation based on inverse distance weight (IDW) spatial analysis indicated that contaminated drinking water may be found throughout the valley's northern, central, and lower reaches. The report advised that water quality be monitored on a regular and frequent basis to examine pollution sources and ensure public health in the area. Furthermore, water treatment should be created to ensure that people have access to healthy and drinkable water.

Acknowledgements

The authors gratefully acknowledge the financial support provided by the M/S Hilton Phrama (Pvt.) Ltd Pakistan for the execution of this study.

Authors' Contribution

All authors of the paper have actively contributed to the scientific study reported in the paper and to the preparation of the manuscript.

Data Availability

The datasets generated during and/or analyzed during the current study are available from the corresponding author on reasonable request.

Conflicts of Interest

The authors declare no conflicts of interest regarding the publication of this paper.

References

- [1] Nyakundi, V., Munala, G., Makworo, M., Shikuku, J., Ali, M., Song'oro, E., et al. (2020) Assessment of Drinking Water Quality in Umoja Innercore Estate, Nairobi. *Journal of Water Resource and Protection*, **12**, 36-49. <https://doi.org/10.4236/jwarp.2020.121002>
- [2] Yasin, S.N.T.M., Yunus, M.F.M. and Wahab, N.B.A. (2020) The Development of Water Quality Monitoring System Using Internet of Things. *Journal of Educational and Learning Studies*, **3**, 14-20. <https://doi.org/10.32698/0852>
- [3] PLi, P. and Wu, J. (2019) Drinking Water Quality and Public Health. *Exposure and Health*, **11**, 73-79. <https://doi.org/10.1007/s12403-019-00299-8>
- [4] Şener, Ş., Şener, E. and Davraz, A. (2017) Evaluation of Water Quality Using Water Quality Index (WQI) Method and GIS in Aksu River (SW-Turkey). *Science of the Total Environment*, **584**, 131-144. <https://doi.org/10.1016/j.scitotenv.2017.01.102>
- [5] Javed, T., Sarwar, T., Ullah, I., Ahmad, S. and Rashid, S. (2019) Evaluation of Groundwater Quality in District Karak Khyber Pakhtunkhwa, Pakistan. *Water Science*, **33**, 1-9. <https://doi.org/10.1080/11104929.2019.1626630>
- [6] Bashir, N., Saeed, R., Afzaal, M., Ahmad, A., Muhammad, N., Iqbal, J., Khan, A., Maqbool, Y. and Hameed, S. (2020) Water Quality Assessment of Lower Jhelum Canal in Pakistan by Using Geographic Information System (GIS). *Groundwater for Sustainable Development*, **10**, Article ID: 100357. <https://doi.org/10.1016/j.gsd.2020.100357>
- [7] Bhatti, N.B., Siyal, A.A., Qureshi, A.L., Solangi, G.S., Memon, N.A. and Bhatti, I.A. (2020) Impact of Small Dam's Construction on Groundwater Quality and Level Using Water Quality Index (WQI) and GIS: Nagarparkar Area of Sindh, Pakistan. *Human and Ecological Risk Assessment: An International Journal*, **26**, 2586-2607. <https://doi.org/10.1080/10807039.2019.1674634>
- [8] Ali, S., Hussain, A., Hussain, A., Ali, A. and Awan, M.S. (2013) Drinking Water Quality Assessment in Some Selected Villages of Nagar Valley Gilgit-Baltistan, Pakistan. *Journal of Chemical, Biological and Physical Sciences*, **3**, 567-574.
- [9] Ahsan, W.A., Ahmad, H.R., Farooqi, Z.U.R., Sabir, M., Ayub, M.A., Rizwan, M. and Ilic, P. (2021) Surface Water Quality Assessment of Skardu Springs Using Water Quality Index. *Environmental Science and Pollution Research*, **28**, 20537-20548. <https://doi.org/10.1007/s11356-020-11818-5>
- [10] Farhat, N., Hussain, S., Faisal, F., Batool, I. and Noreen, M. (2021) Physico-Chemical Characteristics and Therapeutic Potential of Chutrun Thermal Springs in Shigar Valley, Gilgit-Baltistan (Pakistan). *Applied Water Science*, **11**, 1-8. <https://doi.org/10.1007/s13201-020-01354-5>
- [11] Fatima, S.U., Khan, M.A., Siddiqui, F., Mahmood, N., Salman, N., Alamgir, A. and Shaukat, S.S. (2022) Geospatial Assessment of Water Quality Using Principal Components Analysis (PCA) and Water Quality Index (WQI) in Basho Valley, Gilgit Baltistan (Northern Areas of Pakistan). *Environmental Monitoring and Assessment*, **194**, 151. <https://doi.org/10.1007/s10661-022-09845-5>
- [12] Hussain, T., Sheikh, S., Kazami, J.H., Hussain, M., Hussain, A., Hassan, N.U., Hussain, Z. and Khan, H. (2014) Geo-Spatial Assessment of Tap Water and Air Quality in Gilgit City Using Geographical Information System. *Journal of Biodiversity and Environmental Sciences*, **5**, 49-54.
- [13] Seong, Y.B., Owen, L.A., Bishop, M.P., Bush, A., Clendon, P., Copland, L., Finkel, R., Kamp, U. and Shroder Jr., J.F. (2007) Quaternary Glacial History of the Central Karakoram. *Quaternary Science Reviews*, **26**, 3384-3405.

- <https://doi.org/10.1016/j.quascirev.2007.09.015>
- [14] Abbas, Z., Khan, S.M., Alam, J., Khan, S.W. and Abbasi, A.M. (2017) Medicinal Plants Used by Inhabitants of the Shigar Valley, Baltistan Region of Karakorum Range-Pakistan. *Journal of Ethnobiology and Ethnomedicine*, **13**, 1-15. <https://doi.org/10.1186/s13002-017-0172-9>
- [15] APHA (2005) Standard Methods for the Examination of Water and Wastewater. 21st Edition, American Public Health Association, Washington DC.
- [16] Mallmann, W.L. and Seligmann, E.B.J. (1950) A Comparative Study of Media for the Detection of Streptococci in Water and Sewage. *American Journal of Public Health and the Nations Health*, **40**, 286-289. <https://doi.org/10.2105/AJPH.40.3.286>
- [17] Mustapha, A., Aris, A.Z., Ramli, M.F. and Juahir, H. (2012) Temporal Aspects of Surface Water Quality Variation Using Robust Statistical Tools. *The Scientific World Journal*, **2012**, Article ID: 294540. <https://doi.org/10.1100/2012/294540>
- [18] IBM Corp. (2013) IBM SPSS Statistics for Windows (Version 22). IBM Corp., Armonk. <https://hadoop.apache.org>
- [19] Abdi, H. and Williams, J.L. (2010) Computational Statistics: Principal Component Analysis. *Wiley Interdisciplinary Reviews Computational Statistics*, **2**, 433-459. <https://doi.org/10.1002/wics.101>
- [20] Gorgoglione, A., Gioia, A. and Iacobellis, V. (2019) A Framework for Assessing Modeling Performance and Effects of Rainfall-Catchment-Drainage Characteristics on Nutrient Urban Runoff in Poorly Gauged Watersheds. *Sustainability*, **11**, 4933. <https://doi.org/10.3390/su11184933>
- [21] Alamgir, A., Fatima, N., Khan, M.A. and Shaikat, S.S. (2015) Microbiological Assessment of Street Vended Fresh Fruit Juices Available in the Karachi City. *International Journal of Biology and Biotechnology*, **12**, 505-509.
- [22] Yang, W., Zhao, Y., Wang, D., Wu, H., Lin, A. and He, L. (2020) Using Principal Components Analysis and IDW Interpolation to Determine Spatial and Temporal Changes of Surface Water Quality of Xin'anjiang River in Huangshan, China. *International Journal of Environmental Research and Public Health*, **17**, 2942. <https://doi.org/10.3390/ijerph17082942>
- [23] IBM Corp. (2021) IBM SPSS Statistics for Windows. Version 28. IBM Corp., Armonk.
- [24] OriginLab (2022) OriginPro 2022 (No. v2022). OriginLab Corporation, Northampton. <https://www.originlab.com>
- [25] RStudio Team (2020) RStudio: Integrated Development Environment for R. <http://www.rstudio.com>
- [26] Elumalai, V., Brindha, K., Sithole, B. and Lakshmanan, E. (2017) Spatial Interpolation Methods and Geostatistics for Mapping Groundwater Contamination in a Coastal Area. *Environmental Science and Pollution Research*, **24**, 11601-11617. <https://doi.org/10.1007/s11356-017-8681-6>
- [27] Haldar, K., Kujawa-Roeleveld, K., Dey, P., Bosu, S., Datta, D.K. and Rijnaarts, H.H.M. (2020) Spatio-Temporal Variations in Chemical-Physical Water Quality Parameters Influencing Water Reuse for Irrigated Agriculture in Tropical Urbanized Deltas. *Science of the Total Environment*, **708**, Article ID: 134559. <https://doi.org/10.1016/j.scitotenv.2019.134559>
- [28] Nistor, M.M., Rahardjo, H., Satyanaga, A., Hao, K.Z., Xiaosheng, Q. and Sham, A.W.L. (2020) Investigation of Groundwater Table Distribution Using Borehole Piezometer Data Interpolation: Case Study of Singapore. *Engineering Geology*, **271**, Article ID: 105590. <https://doi.org/10.1016/j.enggeo.2020.105590>
- [29] ESRI (2020) ArcGIS Desktop: Release 10.8.1. Environmental Systems Research Insti-

tute, Redlands.

- [30] WHO (2011) Guidelines for Drinking-Water Quality. 4th Edition, World Health Organization, Geneva. <https://www.who.int/publications/i/item/9789241549950>
- [31] Shedayi, A.A., Jan, N., Riaz, S. and Xu, M. (2015) Drinking Water Quality Status in Gilgit, Pakistan and WHO Standards. *Science International*, **27**, 2305-2311.
- [32] Begum, F., Rubina, K.A., Khan, A., Hussain, I., Ishaq, S. and Ali, S. (2014) Water Quality Assessment Using Macroinvertebrates as Indicator in Sultanabad Stream (Nallah), Gilgit, Gilgit-Baltistan, Pakistan. *Journal of Biodiversity and Environmental Sciences*, **5**, 564-572.
- [33] Islam, N., Ahmed, K., Nafees, M.A., Khalil, M., Hussain, I., Ali, M. and Imran, R. (2021) Physico-Chemical and Bacteriological Analysis of Drinking Water of Springs of Sherqilla, District Ghizer, Gilgit-Baltistan, Pakistan. *Pakistan Journal of Zoology*, **53**, 1-8. <https://doi.org/10.17582/journal.pjz/20160717150758>
- [34] Baig, S., Begum, F., Raut, N., Khan, M.Z., Mumtaz, S., Ali, M. and Ali, K. (2019) Spatio-Temporal Variation of Selected Heavy Metals in Drinking Water Systems of Central Hunza, Gilgit-Baltistan, Pakistan. *Fresenius Environmental Bulletin*, **28**, 207-214.
- [35] Lodhi, Z.H., Akif, M. and Kalsoom, U. (2003) Evaluation of Drinking Water from Different Sources in Skardu-Northern Area with Special Reference to Heavy Metals. *Journal of the Chemical Society of Pakistan*, **25**, 110.
- [36] Muhammad, S. and Ahmad, K. (2020) Heavy Metal Contamination in Water and Fish of the Hunza River and Its Tributaries in Gilgit-Baltistan: Evaluation of Potential Risks and Provenance. *Environmental Technology & Innovation*, **20**, Article ID: 101159. <https://doi.org/10.1016/j.eti.2020.101159>
- [37] Nafees, M.A., Ahmed, K., Ali, S., Karim, R. and Khan, T. (2014) Bacteriological Analysis of Drinking Water Sources in CKNP Region of Gilgit Baltistan, Pakistan. *International Journal of Biosciences*, **5**, 54-59. <https://doi.org/10.12692/ijb/5.4.54-59>
- [38] Huang, Z., Liu, C., Zhao, X., Dong, J. and Zheng, B. (2020) Risk Assessment of Heavy Metals in the Surface Sediment at the Drinking Water Source of the Xiangjiang River in South China. *Environmental Sciences Europe*, **32**, Article No. 23. <https://doi.org/10.1186/s12302-020-00305-w>
- [39] Alamgir, A., Khan, M.A., Shaikat, S.S., Majeed, R. and Fatima, S.U. (2019) Communal Health Perception of Tap Water Quality Supplied to Shah Faisal Town, Karachi. *International Journal of Biology and Biotechnology*, **16**, 189-198.
- [40] Mustafa, S., Baloch, N., Muhammad, S., Malik, Y., Khan, T., Bibi, M., Qadir, A., Razaque, G. and Baloch, I.A. (2017) Determination of Trace and Heavy Metals in Drinking Water of Jhal Magsi District of Balochistan, Pakistan. *Pure and Applied Biology (PAB)*, **6**, 9-17. <https://doi.org/10.19045/bspab.2016.50161>
- [41] Radwan, M.A. and Salama, A.K. (2006) Market Basket Survey for Some Heavy Metals in Egyptian Fruits and Vegetables. *Food and Chemical Toxicology*, **44**, 1273-1278. <https://doi.org/10.1016/j.fct.2006.02.004>
- [42] Iyare, P.U. (2019) The Effects of Manganese Exposure from Drinking Water on School-Age Children: A Systematic Review. *Neurotoxicology*, **73**, 1-7. <https://doi.org/10.1016/j.neuro.2019.02.013>
- [43] Smedley, P.L., Cooper, D.M. and Lapworth, D.J. (2014) Molybdenum Distributions and Variability in Drinking Water from England and Wales. *Environmental Monitoring and Assessment*, **186**, 6403-6416. <https://doi.org/10.1007/s10661-014-3863-x>
- [44] Majeed, R., Khan, M.A., Fatima, S.U., Mahmood, N., Sulman, N. and Shaikat, S.S. (2020) Public Health Status and Socioeconomic Conditions in Climate Change-Affected Northern Areas of Pakistan. *International Journal of Biology and Biotechnology*, **17**, 307-317.