

Gene Frantz
Principal Fellow,
Texas Instruments

Dave Freeman
Fellow, Chief Technologist,
Power Product Solutions,
Texas Instruments

Chris Link
Product and Business Development Manager,
Battery Management Solutions,
Texas Instruments

Overview

The wireless communications network that surrounds us is expanding to include new applications that extend the role of traditional area networks, often by providing intelligence for previously unintelligent objects. Collectively dubbed the “Internet of Things” or the “swarm” (courtesy of Jan Rabaey, UC Berkley), these new devices gather data, report, and at times act on conditions autonomously. Due to their small scale and vast numbers, the new systems will dramatically change areas such as transportation, building and city management, healthcare, personal life, and more. Developing these new, often miniscule, extremely low-powered systems requires that companies such as Texas Instruments (TI) address significant challenges in areas such as computing, communications and energy harvesting, as well as traditional issues in miniaturization and power reduction. TI, leveraging its recognized expertise in embedded processing, analog signal chain, power management, and radio for mobile communications, has developed and continues developing advanced technology that enables systems for the Internet of Things.

Extending the edge of the cloud

Low-power design and connectivity for the “Internet of Things”

In recent years, we have become accustomed to speaking of “the cloud” as a centralized resource of computation and storage for enabling our increasingly digital world to function. A gateway of wireless connectivity to the cloud allows us to use computers, cellphones and entertainment devices almost everywhere we go. As new types of ultra-low-power (ULP) networked systems come into existence, we see that we are able to create the intelligent environment with distributed computing reaching almost everything we can think of. Anything that can be given an electronic circuit and has reason to communicate with other systems remotely is a candidate, including gauges, sensors, meters, thermostats, switches, medical monitors, motors, household appliances, vehicles, tools, even items of clothing and kitchen utensils. Whatever you name, it may soon become part of this fast-growing swarm of systems (Figure 1), the so-called “Internet of Things,” that is beginning to hover about the periphery of the cloud.

While the number of nodes already linked to the cloud is huge, adding up to billions of units, it is dwarfed by the potential number of these new ULP systems that are starting to come



Figure 1. The swarm around the cloud.

online today. Eventually there will be *trillions* of these devices, the equivalent of thousands for every man, woman and child on earth. ULP systems will discover, report and automatically act on conditions that today require time-consuming and sometimes wasteful human intervention. These applications can include actions as varied as monitoring and controlling personal health parameters, safe and energy efficient operation of a car as it drives through crowded streets, and the efficient allocation of resources and disposal of wastes in megacities. In fact, the range of applications is only limited by our imagination. The intelligent swarm will be ubiquitous, helping to keep our bodies healthy, our buildings comfortable, our cities efficient, and above all minimize waste of precious natural resources.

Requirements at the edge of the cloud

Because of its scale, the Internet of Things is already a major driver in the development of electronic technology. What kinds of challenges face technology innovators, including TI, in order to make this new range of connectivity possible? In general, three areas of development are necessary: effective computation for very small-scale devices, availability of wireless communication for so many connections, and ongoing conversion of energy from ambient sources in order to minimize battery maintenance.

Computation is a question of efficiency, since the systems are very small in scale and need to minimize power consumption. Also, there are issues of how to distribute computation across such an enormous network. Will the models of distributed computing that networks follow today apply when there are trillions of nodes, or will new models need to be developed? In many cases multiple devices may operate in conjunction, so how can computing tasks best be allocated on the fly in ever-changing configurations of devices?

Network scale also affects communication. Since wireless bandwidth is always limited, what modulation schemes and protocols will be necessary to optimize its use when so many channels are open? Also, will the switching and routing techniques that are in use today be sufficient to carry us along into an era when data traffic is thousands of times greater? These are questions that only hard research and hard-won practical experience can answer.

To keep the Internet of Things going, techniques of gathering or harvesting energy from ambient light, vibration, heat and other environmental sources will require continuous improvements. ULP systems will be tiny, often difficult to access, sometimes in hazardous places, and around us in such huge numbers that we won't be able to charge or change their batteries all the time. The systems will have to look after themselves by harvesting energy, either to recharge their batteries autonomously or run without batteries altogether.

Finally, in addition to the challenges of computation, communication and energy harvesting, component manufacturers and system designers are also faced with extreme requirements for miniaturization and power reduction. Many applications, such as medical implants, will need to fit into spaces that have previously not been networked. Such systems will have to be reduced from the size of a deck of cards to that of a button—a 100× reduction. Average power consumption will have to drop even more sharply, with a 1000× reduction in going from microwatts (μW) to nanowatts (nW).

Developments in each of these areas will quickly add up to major changes in embedded circuitry to enable new applications—including many that haven't occurred to us yet. (For discussion of the potential range of new applications, see [Approaching the horizon of energy harvesting: TI technology opens new frontiers for perpetual devices](#).)

TI innovation for ULP systems

To see what these requirements mean in terms of circuit components, it is helpful to consider that ULP networked systems break down into five major blocks: a sensor that gathers input from the environment; a wireless transceiver that communicates with the network; a digital microcontroller that performs the necessary computations to do whatever the system is designed to do; an analog block that conditions and converts signals between the sensor or transceiver and controller; and a block that provides power for all other blocks (Figure 2). There is room for improvement in size and power consumption in all of these areas.

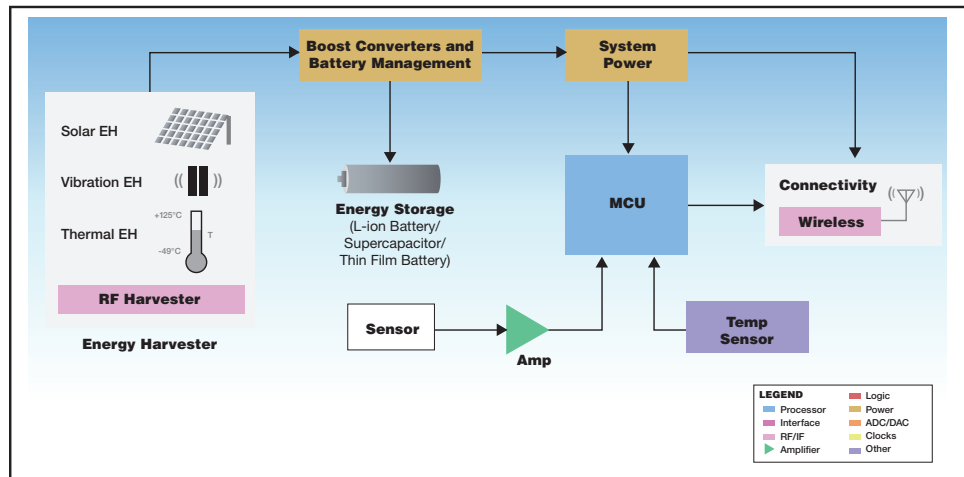

Figure 2. TI develops advanced technology for a complete ULP system.

TI, long an industry leader in developing the necessary technology for cellphones and mobile computing, has used its expertise to create solutions for these blocks. The company is well-positioned to extend that expertise with future solutions that will enable even more ULP networked systems. At the heart of the system, TI offers the industry's lowest-power 16-bit microcontroller, the MSP430™ MCU, featuring an architecture that reduces power consumption by 50 percent over any comparable microcontroller available. As the industry's leading producer of analog components, the company offers a wide range of low-power signal converters that connect the processing core of the system with the outer environment. TI's analog expertise also provides outstanding power management solutions, such as the nanopower bq25504 boost charger, which offers exceptional charge control for batteries and supercapacitors in solar-, kinetic- and thermal-harvesting systems. Among the features built into the bq25504 is Maximum Power Point Tracking (MPPT) that optimizes energy collection from the harvester.

The transceiver block is also a prime area for power innovation. For instance, power amplifiers that drive transmissions typically operate at less than 15 percent efficiency, though theoretically they could be as high as 100 percent efficient. TI continues to be involved in in-depth research that can improve these ratings through component and circuit design and enhanced modulation schemes. A long-term innovator in radio frequency (RF) technology, TI offers the industry's broadest wireless portfolio, including low-power solutions for short range, long range, mesh and IP networks, personal area networks and locationing, as well as mobile handset connectivity and industrial, scientific and medical (ISM) bands. Of particular note for sensors and other ultra-low-power applications are system-on-chip CC2500 devices that integrate both RF circuitry and MSP430 microcontrollers. Remote wireless sensors, such as those that monitor the structural integrity of bridges and buildings, have benefited greatly from the availability of these components.

Sensors for system input are as varied as the wide range of environments where applications operate. For instance, the company's TMP006 infrared MEMS temperature sensor reduces both device power consumption and size by more than 90 percent, giving manufacturers of smartphones, tablets and notebooks the ability to accurately measure device case temperature. Using the TMP006, these manufacturers will also be able to measure the temperature of objects outside the mobile device, unleashing an entirely new functionality for apps developers to tap into. TI also manufactures sensor analog front ends (AFE) such as the highly integrated LMP91050 nondispersive infrared gas sensor AFE, which enables ultra-compact sensing solutions used to detect CO2 and refrigerants such as Freon for demand control ventilation, building monitoring, and industrial safety and security applications. TI also partners with automotive manufacturers to develop sensors for a number of uses, including engine and drive train control, maintenance of a comfortable cabin environment, and vehicle sensing by radar to help drivers navigate traffic and avoid people, animals and objects on the road.

Facing the challenges ahead

Today, the edge of the cloud is becoming an intelligent mist of technology that surrounds us to make our lives automatically safer and more comfortable. While it is unclear what many of the specific applications will be in the emerging Internet of Things, we can be certain that the creation of ULP devices that sense, report and anticipate and adapt on conditions autonomously is a major driver of technology today. In order to enable these applications, technology innovators must face the challenges of computation, communications and energy harvesting, while also dramatically reducing system size and power consumption.

TI is well-positioned to address these issues, based on the company's long-established expertise in developing ULP control, power, analog signal chains, and RF technology for mobile phones and computers. TI also leverages its own development effort through partnerships and industry alliances in order to extend technology into new areas. As the emerging swarm of ULP systems links to the traditional network cloud, TI technology will play a major role in providing us with greater health, security and resource efficiency.

For more information about what's on the horizon with the Internet of Things and cloud computing, visit www.ti.com/cloud-wp-lp.

Important Notice: The products and services of Texas Instruments Incorporated and its subsidiaries described herein are sold subject to TI's standard terms and conditions of sale. Customers are advised to obtain the most current and complete information about TI products and services before placing orders. TI assumes no liability for applications assistance, customer's applications or product designs, software performance, or infringement of patents. The publication of information regarding any other company's products or services does not constitute TI's approval, warranty or endorsement thereof.

The platform bar is a trademark of Texas Instruments.
All other trademarks are the property of their respective owners.

B011012

IMPORTANT NOTICE

Texas Instruments Incorporated and its subsidiaries (TI) reserve the right to make corrections, enhancements, improvements and other changes to its semiconductor products and services per JESD46, latest issue, and to discontinue any product or service per JESD48, latest issue. Buyers should obtain the latest relevant information before placing orders and should verify that such information is current and complete. All semiconductor products (also referred to herein as "components") are sold subject to TI's terms and conditions of sale supplied at the time of order acknowledgment.

TI warrants performance of its components to the specifications applicable at the time of sale, in accordance with the warranty in TI's terms and conditions of sale of semiconductor products. Testing and other quality control techniques are used to the extent TI deems necessary to support this warranty. Except where mandated by applicable law, testing of all parameters of each component is not necessarily performed.

TI assumes no liability for applications assistance or the design of Buyers' products. Buyers are responsible for their products and applications using TI components. To minimize the risks associated with Buyers' products and applications, Buyers should provide adequate design and operating safeguards.

TI does not warrant or represent that any license, either express or implied, is granted under any patent right, copyright, mask work right, or other intellectual property right relating to any combination, machine, or process in which TI components or services are used. Information published by TI regarding third-party products or services does not constitute a license to use such products or services or a warranty or endorsement thereof. Use of such information may require a license from a third party under the patents or other intellectual property of the third party, or a license from TI under the patents or other intellectual property of TI.

Reproduction of significant portions of TI information in TI data books or data sheets is permissible only if reproduction is without alteration and is accompanied by all associated warranties, conditions, limitations, and notices. TI is not responsible or liable for such altered documentation. Information of third parties may be subject to additional restrictions.

Resale of TI components or services with statements different from or beyond the parameters stated by TI for that component or service voids all express and any implied warranties for the associated TI component or service and is an unfair and deceptive business practice. TI is not responsible or liable for any such statements.

Buyer acknowledges and agrees that it is solely responsible for compliance with all legal, regulatory and safety-related requirements concerning its products, and any use of TI components in its applications, notwithstanding any applications-related information or support that may be provided by TI. Buyer represents and agrees that it has all the necessary expertise to create and implement safeguards which anticipate dangerous consequences of failures, monitor failures and their consequences, lessen the likelihood of failures that might cause harm and take appropriate remedial actions. Buyer will fully indemnify TI and its representatives against any damages arising out of the use of any TI components in safety-critical applications.

In some cases, TI components may be promoted specifically to facilitate safety-related applications. With such components, TI's goal is to help enable customers to design and create their own end-product solutions that meet applicable functional safety standards and requirements. Nonetheless, such components are subject to these terms.

No TI components are authorized for use in FDA Class III (or similar life-critical medical equipment) unless authorized officers of the parties have executed a special agreement specifically governing such use.

Only those TI components which TI has specifically designated as military grade or "enhanced plastic" are designed and intended for use in military/aerospace applications or environments. Buyer acknowledges and agrees that any military or aerospace use of TI components which have **not** been so designated is solely at the Buyer's risk, and that Buyer is solely responsible for compliance with all legal and regulatory requirements in connection with such use.

TI has specifically designated certain components which meet ISO/TS16949 requirements, mainly for automotive use. Components which have not been so designated are neither designed nor intended for automotive use; and TI will not be responsible for any failure of such components to meet such requirements.

Products

Audio	www.ti.com/audio
Amplifiers	amplifier.ti.com
Data Converters	dataconverter.ti.com
DLP® Products	www.dlp.com
DSP	dsp.ti.com
Clocks and Timers	www.ti.com/clocks
Interface	interface.ti.com
Logic	logic.ti.com
Power Mgmt	power.ti.com
Microcontrollers	microcontroller.ti.com
RFID	www.ti-rfid.com
OMAP Applications Processors	www.ti.com/omap
Wireless Connectivity	www.ti.com/wirelessconnectivity

Applications

Automotive and Transportation	www.ti.com/automotive
Communications and Telecom	www.ti.com/communications
Computers and Peripherals	www.ti.com/computers
Consumer Electronics	www.ti.com/consumer-apps
Energy and Lighting	www.ti.com/energy
Industrial	www.ti.com/industrial
Medical	www.ti.com/medical
Security	www.ti.com/security
Space, Avionics and Defense	www.ti.com/space-avionics-defense
Video and Imaging	www.ti.com/video

TI E2E Community

e2e.ti.com