

Development of Battery Management System for Electric Vehicles*

Muhammad Hamza Mehdi¹, Ali Ahmad¹ and Qi Li^{2,†}

¹ Department of Electrical Engineering Faculty of Engineering, University of Central Punjab, 1 - Khayaban-e-Jinnah Road, Johar Town, Lahore, Pakistan

² Graduate School of Science and Engineering, Ritsumeikan University, 1-1-1 Noji-higashi, Kusatsu, Shiga, Japan 525-8577

Abstract

The world has shifted from non-renewable resources to renewable resources for the betterment of the environment and to reduce costs. Electric Vehicles play an important role in providing safe and affordable transport. Lithium Ion batteries in electric vehicles require a battery management system to charge their battery-based engine and maintain its health and life. However, currently, battery charging-based systems provide less attention to optimal charging and preserving the health, charge, and life of the batteries. Methods like Constant Current, Constant Voltage, and Constant Current- Constant Voltage provide a fast and reliable charging capacity, but the health and life of the battery pack are often compromised. For that, an innovative management system is developed to monitor the details of the battery's overall progress, health, charging/discharging periods, and the environment of the battery pack. The critical change in this method is the Pulse Width Modulation (PWM) charging method, which provides the necessary charge required by the battery while maintaining the battery's overall characteristics to be adequate for a prolonged life. Unlike the conventional charging methods, the PWM provides a constant charge to the batteries whenever a certain threshold is breached. The PWM has achieved a more precise and reliable battery charging technique, which helps maintain the overall life and produces a better voltage output that allows the system's productivity. Compared to the previous methods, the PWM-based BMS has a fast charging rate and an acceptable discharging curve, which defines the superiority of the PWM over other conventional methods.

1. Introduction

Electric Vehicles are a revolutionary idea introduced as an environment-friendly mode of transportation. Powered solely by electric energy sourced from battery packs, solar panels, or other electric energy devices, these vehicles offer the advantage of emitting zero fossil fuel in the atmosphere. We can all play a part in creating a pollution-free environment by choosing electric vehicles. Thus, EVs also have very low maintenance and fuel costs, as the vehicle's power comes from renewable sources[1].

The demand for EVs has recently drastically risen due to their environment-friendly nature. To date, Lithium Ion Batteries batteries are considered the best source of energy to provide

The 6th International Symposium on Advanced Technologies and Applications in the Internet of Things (ATAIT 2024), August 19-22, 2024, Kusatsu, Japan

[†] Corresponding author.

✉ smhamzamehdi97@gmail.com (M.H. Mehdi); gr0517rs@ed.ritsumei.ac.jp (Q. Li)



© 2024 Copyright for this paper by its authors. Use permitted under Creative Commons License Attribution 4.0 International (CC BY 4.0).



CEUR Workshop Proceedings (CEUR-WS.org)

power to EVs [2][3]. However, the hazardous nature of Li-Ion batteries has restricted their wide application in EVs. To date, there is no efficient charging mode present for Lithium Ion Batteries [4]. In comparison, methods like charging through Constant Current, Constant Voltage, and Constant Current - Constant Voltage have been tested to their extreme limit [5][6][7][8]. However, they still need to provide efficient results when used with Lithium Ion Batteries. Such methods have proven a vast range of application of use for lead-acid batteries and are still used with greater efficiency and results. Moreover, a better charging station for Li-Ion was long-awaited, which could help explore the capacity of these batteries in EVs. In recent years, Pulse Width Modulation demand has been observed due to its minimum discharge rate at dead pulse intervals and fast charge at live pulse intervals [9]. This charging mode can be fruitful in using Li-Ion batteries and can be a more excellent groundbreaking result for using Lithium Ion Batteries in EVs.

1.1. Literature Review

In the past, charging methods have been of use to only charge batteries for storage purposes. However, the life of the batteries, the residual current, temperature, and optimal performance were neglected due to the lack of interest in such developments. Although the vast benefits of Electric Vehicles have made them a major part of our lives, they lag in the charging method. Methods like CC, CV, and CC-CV apply to charge lead-acid and nickel-cadmium batteries and produce a great result in charging in an efficient way. However, these methods fail to produce the same results when used with Lithium Ion Batteries. Lithium Ion Batteries are very sensitive and require extreme care of charging, for which none of the above methods have been fulfilled. Hence, developing of EVs for daily routine usage was incomplete without an efficient charging method.

The use of CC, CV, and CC-CV has produced greater results in charging batteries, including Lithium Ion Batteries. However, the battery's health and life parameters have always discussed insecurity when resorting to these methods. In general, CC, CV, and CC-CV methods did charge batteries in optimal time. However, the life of the batteries was constantly being attacked. Simultaneously, the charge on each battery cell was different, causing a residual current within the battery bank to be present. These techniques need to be rectified and corrected for better and much more stable charging of batteries for the best performance of the EVs.

As seen in figure 2, it is the most basic charging method in EVs at present. Both CC and CV charging methods are derived from simple charging methods. The CC method is responsible for briefly charging the batteries. Once the batteries are fully charged, the system enters in the CV zone, where the current is reduced to a cut-off current value and the charge on batteries is completed. Such type of charging method is easy to create [10].

However, at present, the CC-CV method faces a few major issues.

- With decrease in battery performance due to aging, the battery voltage will increase at a gradual pace that will result in noticeable polarization and high polarization voltage.
- The CV phase is extra-time-consuming, which makes the whole fast charging process unsuitable.
- A high residual current is present in the battery pack due to little CC charging time which would cause dire conditions within the battery cells and reduce battery life.

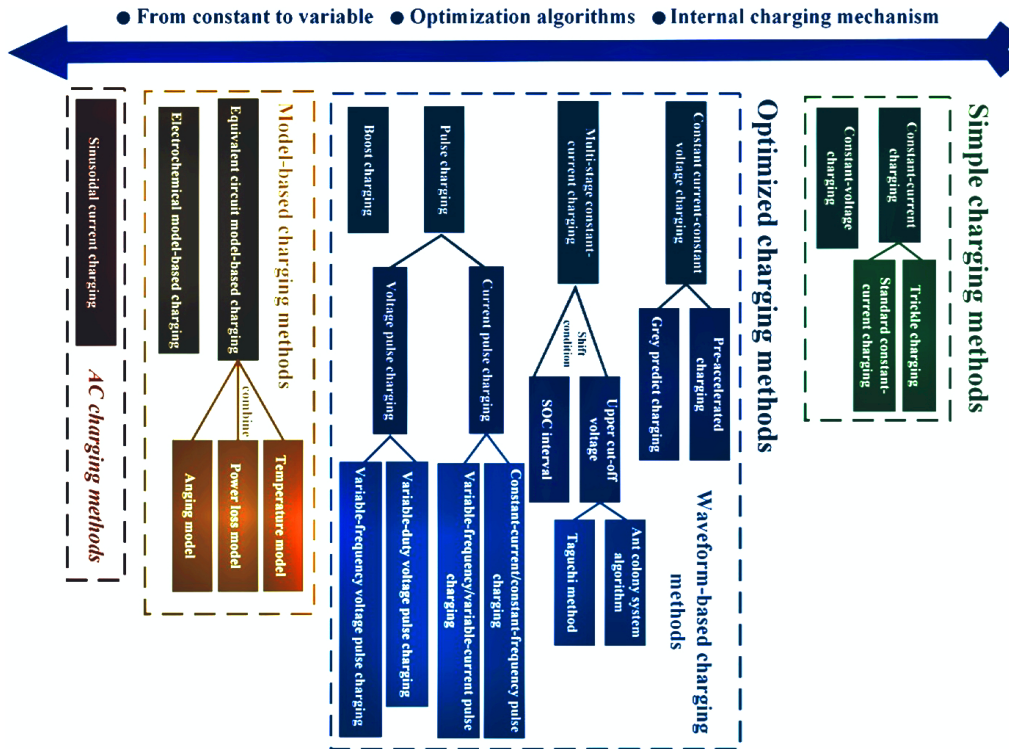

Figure 1: Simple charging methods

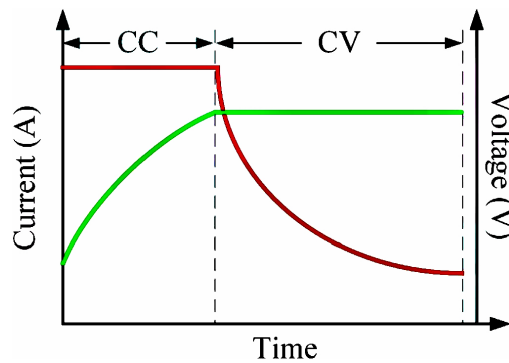

Figure 2: CC-CV Charging Method

- No communication between individual cells as the method does not focus on inter-cell communication.
- A surge in battery temperature is noticed due to neglected internal resistance of the batteries, which causes the overall decrease in efficiency.

Thus, the CC-CV charging method has vast proven positives for charging batteries, however, when it comes to Lithium Ion Batteries, care must be taken. The current CC-CV charging methods tend to continuously charge the batteries. This causes an increase in the stress and

burdens the battery with increased burden. This increased burden causes a decrease in the overall performance of the batteries, the health, charge and the optimal temperature range. This, in succession, decreases the lifetime of the batteries. Hence, an intelligent Battery Management System is required with sufficient capability to clearly monitor the overall performance, temperature sensitivity, health and charge balance and charge/discharge the batteries, without any additional stress on the battery cells. In order to create such a system, the battery cells would be required to communicate and each cells parameters would be necessary to be monitored.

This paper proposes a novel technique for charging Lithium Ion Batteries in an efficient way. The use of PWM charging has seen a great amount of development in recent years, and the integration of such a method in BMS could potentially answer all the questions that are a hindrance to the efficient use of Lithium Ion Batteries. The proposed method would be required to charge batteries with effective care and monitor the temperature, State of Charge, and State of Health of the battery while monitoring the charge state of each individual cell. Such a development, can potentially increase the overall life-span of the batteries and the overall usage of the battery. The PWM method is designed to charge the batteries with respect to their SOC. The duty cycle would be set intelligently by the BMS, depending on the state of battery discharge, charge, temperature of the battery and surroundings, and the requirement of load connected.

1.2. Related Work

Having a BMS system that can monitor multiple modules simultaneously, M. Brandl et al discusses a BMS that can monitor the Li-Ion batteries. Such a BMS would have a hierarchical architecture consisting of a MMU. Further, the Module Management Unit is implemented by inner CMU and provides higher-level services to the PMU. The complete architecture is interconnected by the Controller Area Network (CAN) [11].

In an EVs, the Pack Management Unit is interconnected with the Vehicle Management System, through the CAN bus.

The work of Hongbin et al. discusses the BMS controller for series-parallel connected Lithium Ion Batteries. The BMS would monitor the SOC, SOH and temperature of the Li-Ion pack. To avoid over-charging and the risk of explosion, the proposed BMS would keep track of the battery's health and the security of the battery and the EVs car. The DC/DC converter is designed to monitor SOH/SOC online. The Kalman filter is designed to improve the fast charging efficiency of the battery system. Hongbin et al also proposed an aging mechanism in the BMS to monitor the battery cells [12].

Using an optimized BMS for Lithium Ion Batteries by a multistage CC-CV strategy for charging using particle swarm optimization. Using this method, Yungjian et al. achieve a reduction in battery degradation and reduced charging time. The multi-constant current constant voltage (MCV) strategy is based on three charging strategies: A fast charging method for motorway EVs, a minimum charging strategy for family use, and a balanced charging strategy for daily use. Compared to normal charging methods at 0.5C for CC-CV, the balanced charging method is 3.6% better than the normal charging method. Further, the charging time is reduced by 37%, hence decreasing the issue of over-charging the batteries [6].

In order for the Lithium Ion Batteries to perform in optimal conditions, the SOC plays an

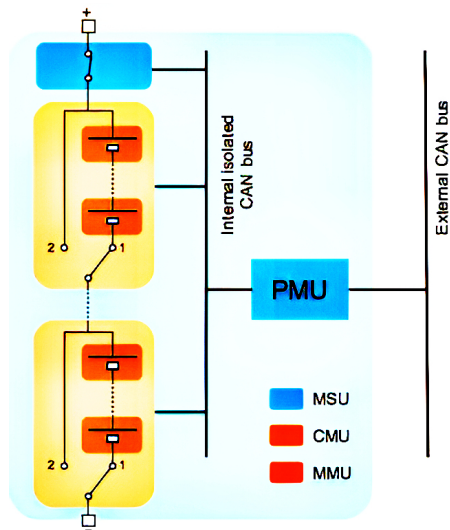

Figure 3: Multi-layer BMS

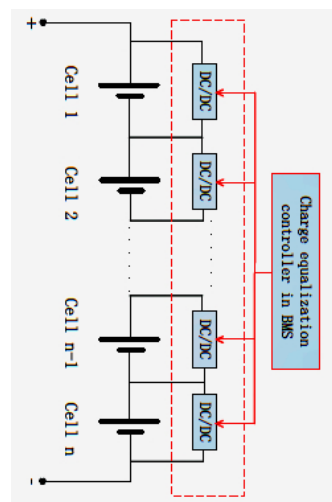

Figure 4: BMS with active charge

important role in charging and discharging the batteries while preserving the health and other parameters of the batteries. Using impedance measuring equipment, Ryu et al. devise a model for charging Lithium Ion Batteries with high efficiency and temperature dependencies. The Extended Kalman Filter provided greater efficiency in the estimation of SOC and temperature compared to conventional techniques like OCV, internal resistance, current accumulation methods, etc. The algorithm depends upon the accuracy of the battery model. Further, the battery model includes the open circuit voltage, OCV, and internal impedance. Ryu et al. calibrate the internal parameters of the Li-Ion batteries using the impedance measuring equipment, which further decides the parameters in the battery model. The results of this technique had significant improvements on SOC and temperature where the error rate was brought less than 1.0% from temperatures between 15 degrees and 45 degrees Celsius. However, improvements in lower temperatures are still required. Furthermore, the accuracy of the algorithm depends upon the battery model. Also, the battery models vary depending upon the battery states, SOC, temperature, and degradation [3].

2. Proposal

To overcome the issue at hand, we propose a Battery Management System, that would govern every parameter of the battery pack and individual battery cells. The BMS would keep track of the overall performance, charge cycle, discharge cycle, and health of the battery pack. In addition, the BMS will also monitor the same indicators on individual cells and provide a communication pathway for individual cells to communicate. The BMS would be responsible for avoiding over-charging / over-discharging of the battery pack by controlling the upper limit of charge, the minimal limit, and extending the life cycle depending upon (SOC), (SOH), keeping temperature in control, monitoring every cell in the pack and fast charging respectively

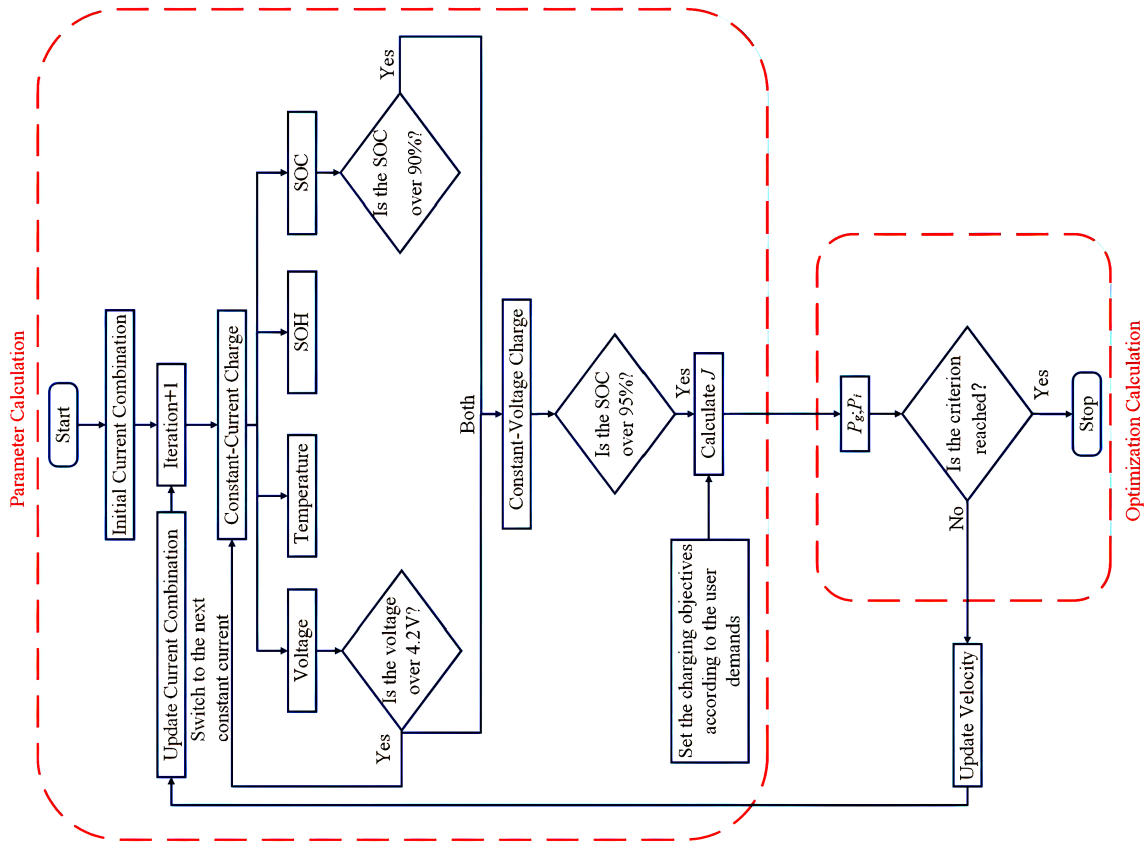

Figure 5: Model Optimization for Optimized charging

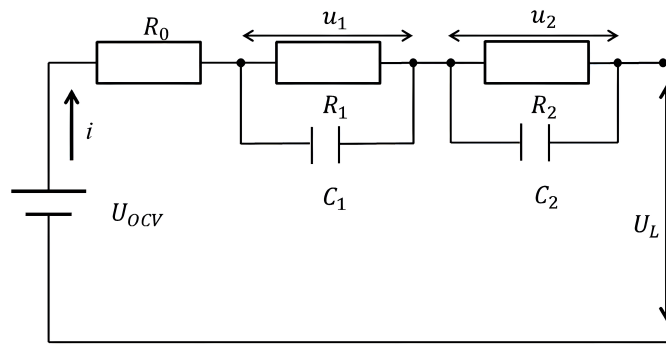

Figure 6: Equivalent Circuit Model of the Li-Ion batteries

[10][12][13].

The BMS consists of a buck-boost converter responsible for amplifying the DC voltage across the battery's terminals. To achieve this DC input, a chopper transformer is connected with a full-bridge rectifier (see fig 8

The batteries would be connected in a series-parallel configuration, maintaining 48V potential

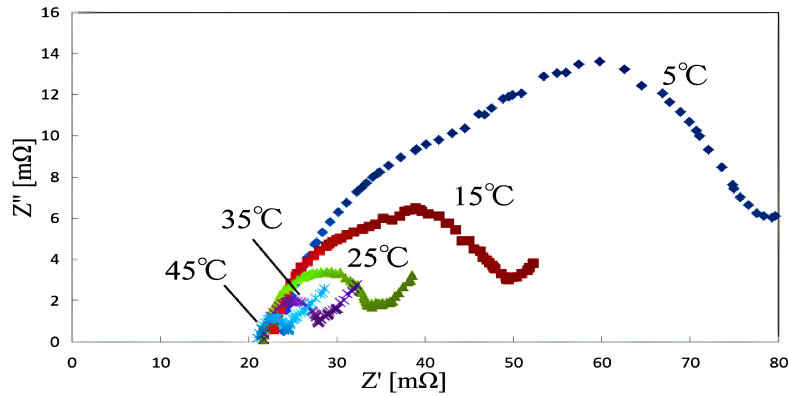

Figure 7: Nyquist plots of Li-Ion batteries for depending temperatures

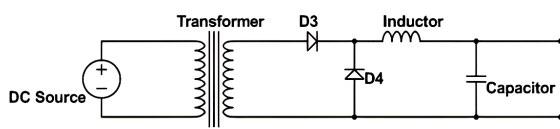

Figure 8: DC-DC Buck-Boost converter with chopper

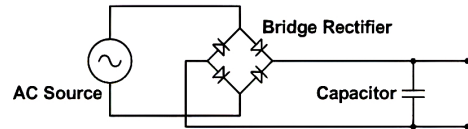

Figure 9: AC to DC Full Bridge Rectifier

on extremes and 10Ah current for load. The BMS is proposed as an intelligent device that charges batteries according to the requirement, not overburdening the overall battery pack. An Arduino controller would govern the stats of SOC, SOH, temperature, and load requirements.

In previous research, the charging methods using CC-CV methods have had their fair play. However, they are not optimal with Lithium Ion Batteries. To facilitate the BMS to charge the batteries with precision and efficiency, a novel idea of Pulse Width Modulation is proposed. The batteries are to be charged in the ON pulse interval. This interval of charging is based solely on the selected duty cycle and the highest efficiency of the PWM. In the OFF pulse interval, we have a dead time. Hence, a zero discharge rate is achieved, which helps the batteries from discharging continuously and helps the charge being maintained in the cells. This also helps the batteries to have an efficient SOH and, hence, have an enhanced life cycle[10][1].

The PWM is set to charge batteries with a duty cycle of 0.45 at no charge present on the batteries. As the charge accumulates, the BMS alters the PWM charging by lowering the duty cycle. Ideally, the duty cycle would vary between 0 and 0.45. This charging method would help maintain the overall health of the battery, as well as the SOC, SOH, and temperature.

Once the batteries are charged, the PWM duty cycle shifts to the discharging curve and supplies power to the load connected while maintaining a healthy battery pack. The BMS will be responsible for controlled discharging and charging and thus would monitor the parameters such as speed, angle, fuel, etc, using information communication through CAN Bus.

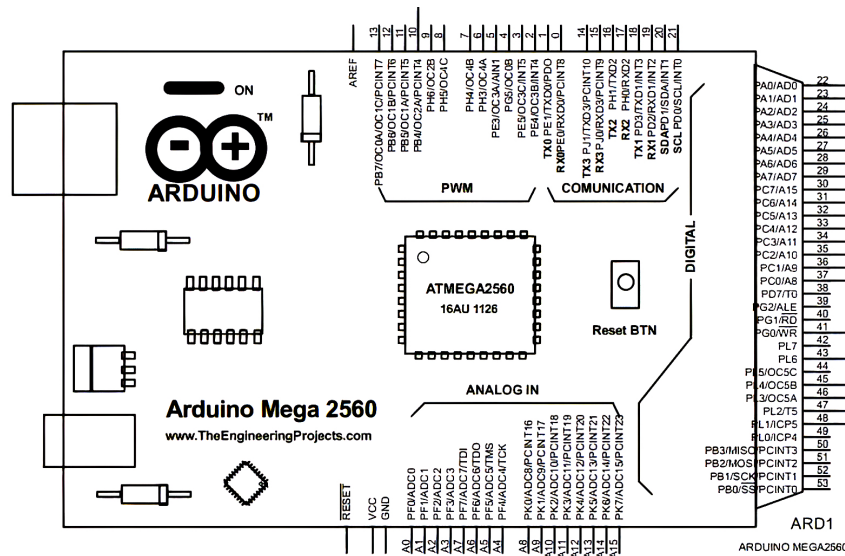

Figure 10: Arduino AtMega 2560 Schematic Diagram

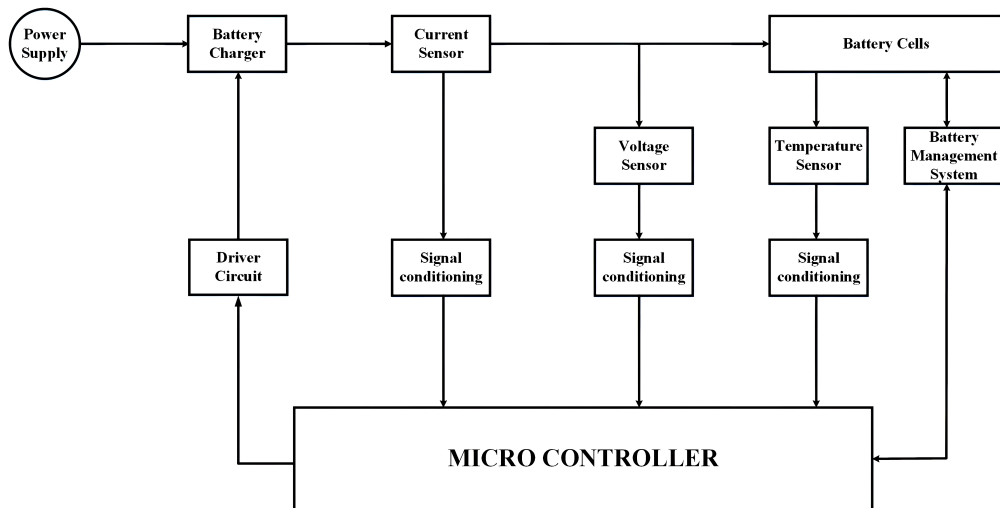

Figure 11: Architecture of BMS proposed

3. Experimentation Analysis

The BMS is designed to monitor the SOH, SOC, temperature, and the charging and discharging of the Li-Ion battery pack. The BMS consists of a DC/DC converter (Chopper) at 25kHz and converts the AC 230V to 311V DC. The full-phase rectifier is used to create pulsating DC voltage from 311V to 48V. The batteries were connected in a Series-Parallel formation, resulting in a total of 48V potential and 10Ah current to the EVs. The BMS is governed by an Arduino

microcontroller that helps in monitoring all the required checkpoints for fast charging. The signal conditioning used would be a governor agent for charging and discharging the lithium-ion batteries by adjusting the duty cycle of PWM.

3.1. Experiment Parameters

The Electric Vehicles used in this case was an electric motorbike, that would use a 12V battery pack output voltage for powering the EVs. In the simulation-based experiment, the design was implemented on Matlab (Simulink).

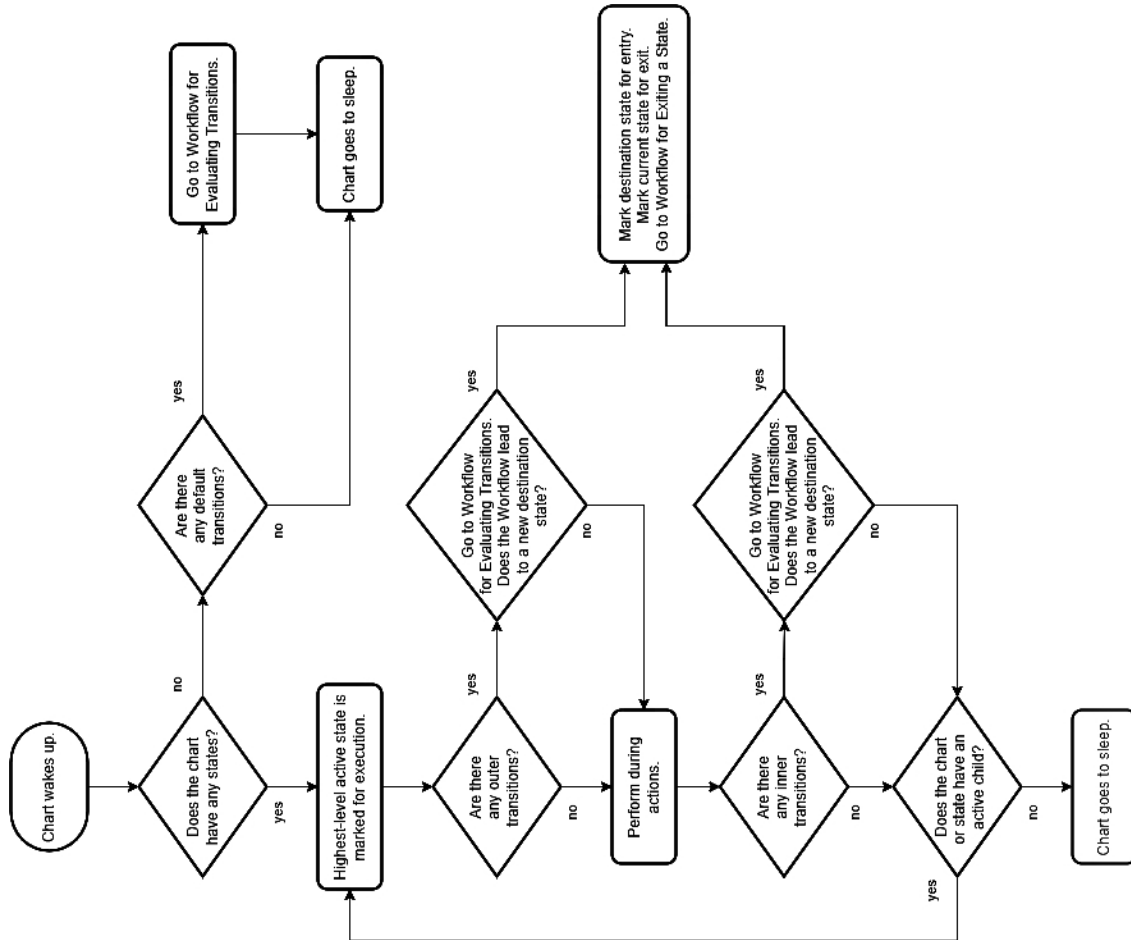

Figure 12: Flowchart of MATLAB implementation

Figure 13 shows the simulation of the BMS on MATLAB. The batteries are designed to start charging after reaching 50% SOC. A charging generator would be implemented within the BMS to charge the Lithium Ion Batteries. Once the complete pack of batteries reaches fully charged, the charging curve would halt.

If a potential difference exists, each cell within the battery has the capacity to charge its

Battery Management System

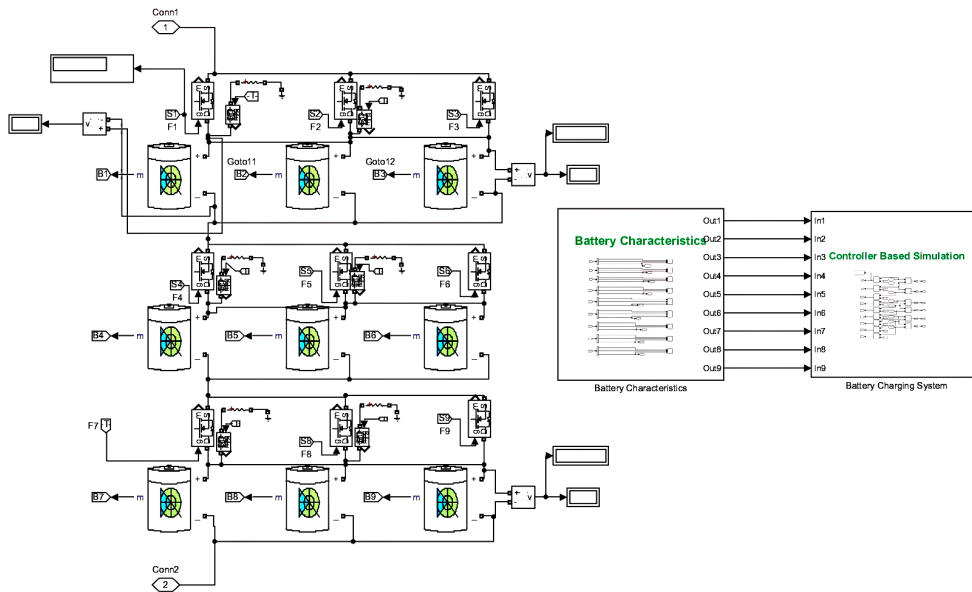

Figure 13: BMS representation on MATLAB

neighboring cell. This feature would keep the overall potential and residual current minimum and keep the batteries in ideal condition.

Once the battery is fully charged and ready to use, the discharging would be as per the figure 14. The discharging rate is set at 0.5C. Furthermore, the remaining characteristics were set as per the charging and discharging conditions of [12].

3.2. Experimental results and Discussion

The simulation was successfully developed with a 3x3 pack of batteries as a test and a load of 1KW. The load was constant throughout the simulation. The battery charging curve is below.

The BMS was able to start charging the batteries when the SOC dropped below 50%. After the charge completion, the load resistor in figure 13 is connected, and the charged batteries discharge as per the requirement of the load. In reality, the load is of the nature of resistive-reactive, and hence, the reverse current towards the BMS can cause issues. For that, the chopper is connected with a forward-based diode that limits the reverse current and avoids the overcharging of the batteries [14].

The BMS was able to spot the ideal SOC, SOH, and temperature and, based on these values, set the duty cycle that keeps the batteries, the cells, and the load efficient. Hence, the overall usage of BMS shows a great deal of success. The SOC achieved was near ideal (98%), and the current

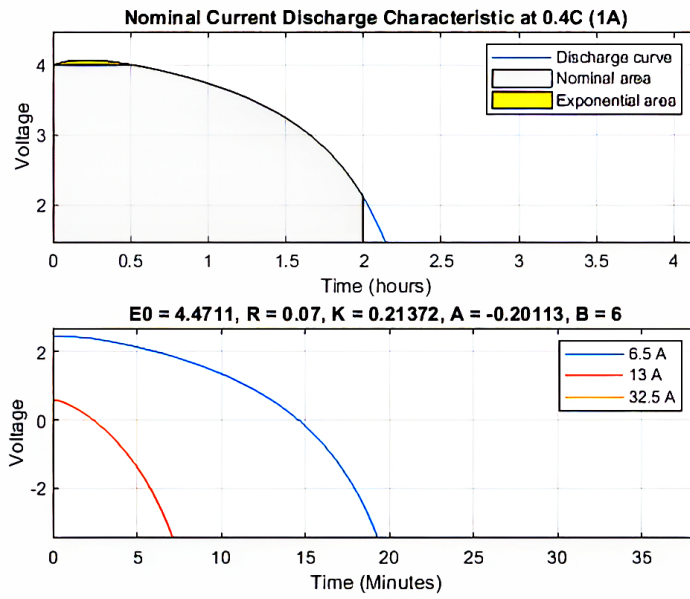

Figure 14: Discharging curves of BMS and Battery Pack

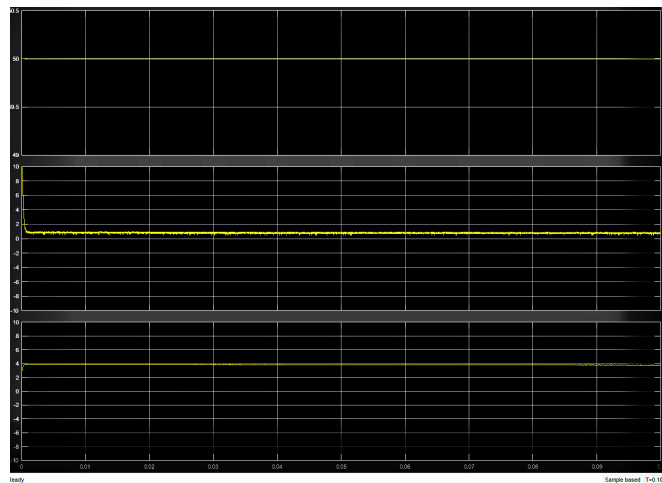

Figure 15: Charging curves of Batteries

supplied for the EVs was 4Ah. This result shows greater supremacy of the BMS using Pulse Width Modulation than other methods. Using CC-CV methodology, with a simple charging method, is in-advantageous and causes the battery to compromise in SOC, SOH, and overall performance of the battery. The PWM method is superior to its predecessors and provides a more flexible approach, depending upon the state of the battery pack and the requirement of load (that was not available in previous methods).

4. Conclusion and Future Work

The BMS-based charging using the novel PWM technique outperformed the previously available methods of charging. The overall battery pack and individual battery cells within the pack were in optimal health and charge. The BMS integrated with PWM ensured a safe and reliable charging method for the Li-Ion pack. Unlike the CC-CV method, the charging and discharging modes in PWM cater to the concerns of overcharging, over-discharging, and temperature management. The BMS also helps in helping each cell in the battery pack to be in adequate condition. Further, the SOC, SOH and temperature components of the BMS helped in the overall management of the battery pack. The discharging rate set at 0.5C would help in managing the load requirement of the series-parallel connected power pack. After the overall SOC drops below 50 %, the charging of the battery pack is initiated by a small generator attached to the BMS. The use of PWM, was set from 0 to 0.45 duty cycle, depending upon the load required of the EVs. The batteries' charging and discharging times were improved over the previously available charging methods, and the overall charging of the Lithium Ion Batteries was faster than the CC, CV, and CC-CV methods. Hence, the PWM method proves to be one of the best available and unique methods compared to other previously known methods.

With the advancement of Deep Learning and innovative Deep Neural Network methods, Deep Learning technology would improve and transform the implementation of Lithium Ion Batteries for EVs applications. Charging rates could be further improved to higher efficiencies with Deep Learning technology. The BMS at current is limited to the characteristics of the battery. However, the use of EVs and the coordination of BMS with CAN bus still needs to be explored. Furthermore, the use of Deep Learning in calculating the use of power from batteries is more effective. Recent developments of EVs and threats for attacks on EVs using spoofing and jammer attacks can be implemented using different DNN algorithms to secure the communication between the BMS and CAN bus, which can also be explored in greater contexts [15][16][17][18].

References

- [1] A. Palihawadana, Electric Vehicle Battery Management System, Ph.D. thesis, 2016. doi:10.13140/RG.2.2.24440.03847.
- [2] L. Lin, H. Ono, M. Fukui, K. Takaba, An in situ full charge capacity estimation algorithm for li-ion batteries using recursive least-squares identification with adaptive forgetting factor tuning, *ECS Transactions* 75 (2017) 111. doi:10.1149/07520.0111ecst.
- [3] R. ISHIZAKI, L. LIN, M. FUKUI, An accurate soc estimation method for lithium-ion batteries which considers thermal variation, *Electrochemistry* 83 (2015) 852–854. doi:10.5796/electrochemistry.83.852.
- [4] M. Arima, L. Lin, M. Fukui, Kalman-filter-based learning of characteristic profiles of lithium-ion batteries, *Sensors* 22 (2022). doi:10.3390/s22145156.
- [5] Z. Li, K. Song, J. Jiang, C. Zhu, Constant current charging and maximum efficiency tracking control scheme for supercapacitor wireless charging, *IEEE Transactions on Power Electronics* 33 (2018) 9088–9100. doi:10.1109/TPEL.2018.2793312.

- [6] Y. Li, K. Li, Y. Xie, J. Liu, C. Fu, B. Liu, Optimized charging of lithium-ion battery for electric vehicles: Adaptive multistage constant current–constant voltage charging strategy, *Renewable Energy* 146 (2020) 2688–2699. doi:<https://doi.org/10.1016/j.renene.2019.08.077>.
- [7] Y. Kitagawa, L. Lin, M. Fukui, An analysis for cooling li-ion battery modules, in: 2014 IEEE Fourth International Conference on Consumer Electronics Berlin (ICCE-Berlin), 2014, pp. 233–237. doi:[10.1109/ICCE-Berlin.2014.7034313](https://doi.org/10.1109/ICCE-Berlin.2014.7034313).
- [8] M. Fukui, S. Minami, T. Mino, K. Goto, K. Matsushima, H. Wakayama, H. Miura, W. Fukui, High performance battery systems and technologies, *Procedia Technology* 18 (2014) 58–62. doi:<https://doi.org/10.1016/j.protcy.2014.11.013>, international workshop on Innovations in Information and Communication Science and Technology, IICST 2014, 3-5 September 2014, Warsaw, Poland.
- [9] Y.-C. Chuang, Y.-L. Ke, High-efficiency and low-stress zvt–pwm dc-to-dc converter for battery charger, *IEEE Transactions on Industrial Electronics* 55 (2008) 3030–3037. doi:[10.1109/TIE.2008.921218](https://doi.org/10.1109/TIE.2008.921218).
- [10] Q. Lin, J. Wang, R. Xiong, W. Shen, H. He, Towards a smarter battery management system: A critical review on optimal charging methods of lithium ion batteries, *Energy* 183 (2019) 220–234.
- [11] A. Hassoune, M. Khafallah, A. Mesbahi, T. Bouragba, An improved approach of control for a battery charger based forward converter and sepic, 2018, pp. 1–6. doi:[10.1109/IRSEC.2018.8703032](https://doi.org/10.1109/IRSEC.2018.8703032).
- [12] H. Ren, Y. Zhao, S. Chen, T. Wang, Design and implementation of a battery management system with active charge balance based on the soc and soh online estimation, *Energy* 166 (2019) 908–917.
- [13] B. M, G. H, W. M, V. Lorentz, M. Giegerich, F. Baronti, F. G, L. Fanucci, R. Roncella, R. Saletti, S. Saponara, T. A, M. Cifrain, P. W, Batteries and battery management systems for electric vehicles, 2012, pp. 971–976. doi:[10.1109/DATE.2012.6176637](https://doi.org/10.1109/DATE.2012.6176637).
- [14] ElectronicsNotes, Full wave rectifier circuit, https://www.electronics-notes.com/articles/analogue_circuits/diode-rectifiers/full-wave-rectifier-circuits.php, 2020. (Accessed on 03/11/2020).
- [15] Z. Li, Y. Ge, X. Yue, L. Meng, Mcad: Multi-classification anomaly detection with relational knowledge distillation, *Neural Computing and Applications* (2024) 1–15.
- [16] Y. Ge, Z. Li, X. Yue, H. Li, Q. Li, L. Meng, Iot-based automatic deep learning model generation and the application on empty-dish recycling robots, *Internet of Things* 25 (2024) 101047.
- [17] Q. Li, H. Li, L. Meng, Deep learning architecture improvement based on dynamic pruning and layer fusion, *Electronics* 12 (2023) 1208.
- [18] T. Lombardo, M. Duquesnoy, H. El-Bouysidy, F. Àren, A. Gallo-Bueno, P. B. Jørgensen, A. Bhowmik, A. Demortière, E. Ayerbe, F. Alcaide, M. Reynaud, J. Carrasco, A. Grimaud, C. Zhang, T. Vegge, P. Johansson, A. A. Franco, Artificial intelligence applied to battery research: Hype or reality?, *Chemical Reviews* 122 (2022) 10899–10969. doi:[10.1021/acs.chemrev.1c00108](https://doi.org/10.1021/acs.chemrev.1c00108).