

# Color optical computing: visualization, numbers, alphabet

Victor Timchenko<sup>1</sup>, Vladik Kreinovich<sup>2</sup> and Yuriy Kondratenko<sup>3,4</sup>

<sup>1</sup> Admiral Makarov National University of Shipbuilding, 054025, av. Geroev of Ukraine, 9, Mykolaiv, Ukraine

<sup>2</sup> University of Texas at El Paso, TX 79968, El Paso, 550 W University, USA

<sup>3</sup> Petro Mohyla Black Sea National University, 054003, 10, 68th Desantnykiv Str., Mykolaiv, Ukraine

<sup>4</sup> Institute of Artificial Intelligence Problems of MES and NAS of Ukraine, Kyiv, 01001, Ukraine

## Abstract

The article is devoted to the development of methods and architecture of optical color computing, techniques of transforming color information for textual representation and numerical calculation, including transmission by optical channels, and thus expanding the functionality of a promising approach to creating artificial intelligence components in decision support systems. This approach is based on the representation of fuzzy information as an information quantum of visible light of a certain color and the construction of an architecture of logical operations based on the additive and subtractive transformation of light radiation using color filters. The paper presents the principles of forming fuzzy input and output color information, algorithms for hybrid calculations with the transformation of optical data into numerical calculus, methods for converting text messages into color information and, further, into numerical encoding. Components of the optical architecture are presented that allow the implementation of transformation algorithms with high computation speed and wide possibilities for constructing parallel structures.

## Keywords

Decision support system, color computing, logical coloroid

## 1. Introduction

People have always been attracted by optics and color, the rainbow always evokes positive feelings, impressionist artists carried not only beauty in their paintings, but they also conveyed sensations, emotions and movement through color. An interesting fact is that the optical telegraph, as a means of transmitting information, arose much earlier than wired telegraphy. For example, the optical telegraph Ochakiv - Mykolaiv (Ukraine), and later Sebastopol - Izmail, was built in 1826 [1]. Wired and radio communications pushed aside optics as a means of transmitting information, but it returned triumphantly in laser and fiber optic technology, and currently in the field of optical computing, including color computing.

The trend of increasing interest in optical computing has been traced since the mid-eighties of the last century. The prospect is seen in the possibility of ensuring high computing performance, predicted low energy costs, and wide possibilities for constructing parallel structures of computing processes and information transfer. Initially, the development of optical architecture used an optocoupler as a substitute for semiconductors in electronic systems and by the early twenties of our century reached the declared performance of up to 1 Tb/s [2].

The main obstacle to the widespread use of such systems is their low manufacturability compared to semiconductors due to a more complex design and low compactness of the elements [3-7]. In parallel to the considered direction with the development of soft computing and fuzzy logic [8], research work on the creation of optical computing systems operating with fuzzy data [9-12].

This required even more complex designs of optical components, because physical principles of light transformation based on polarization, interference, and diffraction were applied, which led to the need to use systems of prisms, moving lasers, diffraction gratings and other similar elements [13].

---

<sup>1</sup>ICST-2024: Information Control Systems & Technologies, September, 23 – 25, 2024, Odesa, Ukraine

✉ v.timchenko58@gmail.com (V.L. Timchenko); vladik@utep.edu (V. Kreinovich); y\_kondrat2002@yahoo.com (Y.P. Kondratenko)

ORCID: 0000-0003-4259-3919 (V.L. Timchenko); 0000-0002-1244-1650 (V. Kreinovich); 0000-0001-7736-883X (Y.P. Kondratenko)



© 2024 Copyright for this paper by its authors. Use permitted under Creative Commons License Attribution 4.0 International (CC BY 4.0).

Currently, a similar trend continues to develop in metasurface complex optics [14] and is predicted by the development of advanced optical chips, which, as researchers hope, will contribute to the introduction of the next generation of optical devices and systems.

The second trend of research in the field of optical computing is to create principles for the formation of databases and the synthesis of logical networks for decision-making systems, or more broadly, components of artificial intelligence systems for decision-making. These developments include the development of color mathematics, three-valued interval logic, representation and operations in the form of fuzzy sets, matrix forms, etc.

The mathematical description of color was standardized in response to the rapid development of color television by the 1976 CIE document, which introduced the color difference formulas CIELAB and CIELUV as the CIE XYZ space (and other three-color spaces) with a limit that equals color differences, i.e. the three CIE XYZ color values (measured using Euclidean distance) do not exactly correspond to the same perceived color differences. Further development of color representation in television technologies required, for example, the improvement of color control and calibration systems necessary for transmitting color information between different devices [15], as well as other applications in this direction [16].

The active development of information technology increasingly attracted researchers to present color as a possible logical element for improving both color television technology [17,18] and the creation of color logic components.

The latter also includes works devoted to creating color calculation models, with the help of which you can perform logical operations with color coding on films, paper or reflectors. Using spectroscopic analysis, the key optical properties of color codes for Boolean operations have been identified [19, 20]. The works highlight the promise of using light as a key component of computing and its applicability to signal processing through optical connections between electronic devices. An approach is proposed based on the simple operation of overlaying a pair of shadow graphics images. Thus, creating optical parallel logic gates for spontaneous and parallel computations with spatial encoding using light sources becomes possible. Uses pairs of superimposed CIELAB-encoded and printed transparencies to demonstrate the Boolean operation of crossing (conjugating) 2-by-2 color matrices based on scanning CIELAB values. It is recognized that the proposed approach is quite primitive, but promising “for manifesting the array-based processing of colors representing print-preserved and digitalized information.” [19].

Technologies such as chemistry [21,22] and biology [23] also have proposed color models for processing fuzzy data.

Sugano's works [24], [25] introduce a color triangle for ranking fuzzy sets in the process of obtaining clear colors from blurred color tones to improve human interaction with a computer system.

The presented approach is based on the construction of a fuzzy color system in which three membership functions are constructed in the form of a color triangle. When constructing a color triangle, three fuzzy sets are used (red, green and blue). Thus, it is proposed to process fuzzy input data into a color triangle system and output an output fuzzy set with the corresponding center of gravity (height) of the color triangle.

As a special chapter of optical computing, optical computer arithmetic [26] arose based on interest in signed-digit arithmetic and its implementation, parallel binary and non-binary (ternary) calculations, modified binary systems, etc.

The ideas in [27,28] (a) are based on concepts from three areas: artificial color, setting fields for training color filters and fuzzy logic, and (b) apply to solving problems of logical computing and pattern recognition.

An analysis of the considered trends in the development of optical computing allows us to identify two main problems that hinder their development and implementation:

- problematic manufacturability of existing structurally complex components of optical architecture;
- lack of a unified systematic approach to the mathematical description of the main sections of optical computing: the formation of an input database, logical derivation of decisions made, visualization of the output data of assessments and decisions and/or transmission of color information to other decision-making and control devices.

In an attempt to overcome the problems mentioned above, the authors [29-34] developed an optical computing approach whose main ideas are:

- optical transformations of color summation RGB and subtraction CMYel are logical operations of disjunction and conjunction;
- technologically, these optical conversions are widely used and developed;
- summing up a certain color combination  $R+G+B = W$  is the decision;
- a new decision is a light beam generated by a white light source;
- color is a quantum of fuzzy information;
- input information is naturally converted into color quanta and introduced using color filters.

Based on the ideas presented, an architecture of logical devices for implementing OR, AND, NOT, NAND, NOR operations were developed, and structures of multi-level optical networks capable of performing logical calculations with big data were proposed [29-32].

A feature of optical color computing is the direct coupling of optical components (coloroids) to the decision structure. The advantages of color computing when building computer networks are ease of implementation, speed of calculations, and the absence of switching elements for the basic logical operations of disjunction and conjunction. The implementation of operations for making simple, new, blocking and opposite decisions will include quite simply implemented ones, but having switching components.

Some specific tasks related to expanding the functionality of the proposed approach in the formation of fuzzy databases, encryption, data storage and transmission of information required the development of applications for describing numeric and text arrays.

Thus, the goal of this paper is to develop a universal mathematical description of hybrid color-alphanumeric transformations and corresponding optical color logic computing architectures covering input, output, and inference.

## 2. Visualization of information based on visible light emission

The decision support system includes the formation of an input database in the form of fuzzy (qualitative) information. An artificial intelligence system (similar to the human mind) naturally involves inputting information just like human sensory organs.

First of all, this is vision, which allows not only to perceive the color of the environment but also, to use color, to assess, for example, the danger of a situation that requires making appropriate decisions. It is also convenient to represent input information in the form of fuzzy sets of information, and for this, it is usually sufficient, if we also accept the logic of reasoning of the human mind, the need to quickly respond to a situation, etc.,  $7 \pm 2$  degrees of gradation of information.

For example, if we simulate the thoughts of a pedestrian when crossing the road. First, he estimates the distance to the approaching car (Fig.1 a): “*very far*” (A), “*far*” (B), “*far enough*” (C), “*close enough*” (D), “*close*” (E), “*very close*” (F). Second, he estimates the speed of the car: “*very slow*”, “*slow*”, “*slow enough*”, “*fast enough*”, “*fast*”, and “*very fast*”. And finally, being an experienced pedestrian, he evaluates his own mistakes during previous crossings, and decides to speed up the transition further: “*very quickly*”, “*quickly*”, and “*quickly enough*”.

Using the same principle, N. Minorsky, approximately 100 years ago, assessed the actions of an “experienced sailor helmsman” and created a PID ship control controller, widely used in an almost unchanged form for effective robust control of moving objects [35].

Similarly, one can evaluate a person’s sensory information by assessing the temperature of the environment and objects: “*very cold*”, “*cold*”, “*cold enough*”, “*hot enough*”, “*hot*”, and “*very hot*”; perception of pain: “*very painful*”, “*painful*”, “*painful enough*”, “*not painful enough*”, “*not painful*”, “*normal*”. You can also evaluate the volume of sounds, and to a lesser extent by gradation: environmental humidity “*very humid*”, “*humid*”, “*dry*”, “*very dry*”; vibration and a number of other similar sensations.

Gradations, naturally, can have nonlinear properties, for example, for a man-pedestrian, the concept of safety is clearly “*very far away*” (scale *a*, Fig.1), but for the feeling of ambient temperature,

both “*very hot*” and “*very cold*” correspond to the concepts of unsafety (circular scale, Fig.1 b). To gradate color relative to the concept of “*safety*”, it is proposed in [30] to use a circular scale (Fig.1 c) to determine the heights of fuzzy sets that describe color, with the corresponding degree of truth to the value 1.

Historically, color gradation has been used to assess the danger of road conditions and weather phenomena, radiation assessment, assessment of the state of the environment, etc. Naturally, maximum danger was assigned the value of red, and safety was assigned the opposite color of the visible light spectrum in the form of green or blue.

Of course, one cannot expand the concepts of, for example, the danger of a situation to the simple perception of human vision of the color red; this can also be an aesthetically favorable assessment. We are only talking about assessments as applied to decision-making systems.

The most important component of the formation of the input array of information in decision-making systems is expert assessments. In works [32,33] we show how naturally and conveniently we transform the input fuzzy database of expert assessments into information quanta corresponding to a certain color.

The logical architecture for processing input color information is based on the use of additive and subtractive transformation of information quanta of a certain color of visible light using color filters. Thus, we carry out the basic logical operations of disjunction and conjunction.

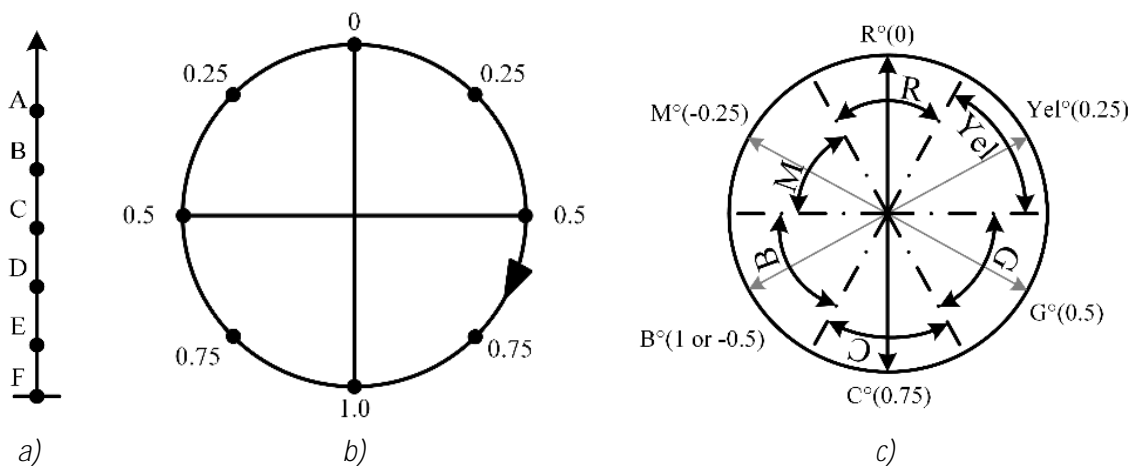

Figure 1: Truth correspondence scales

The addition of light fluxes physically means combining (mixing in equal parts) the corresponding signals of monochromatic color emitters, and subtraction means absorption of the signals of monochromatic light emitters of a certain length (frequency, energy) by the absorbent material of the light filter. Using the visible light range, these operations on color input data are performed without the use of any switching devices or other conversion devices (such as complex prism systems or light polarization) or measurements (such as the wavelength of light) and calculations for the maximum possible speed - speed light. The use of technologically simple light guides of various configurations makes it possible to design logical optical components (coloroids) with the maximum degree of possibility of creating parallel computing structures. Various coloroid structures provide logical operations of negation, NAND, NOR, the output of simple (ordinary) and complex solutions, new and blocking solutions, hybrid computing, and the creation of hierarchically organized coloroid logical networks. These logical operations and decision output use switching devices, which can also be used to translate color calculations into a numerical code, which will be used in section 5 of this work.

The output of the solution in DSS with color calculations is generated (Fig. 1a). as visible white light passing through three RGB filters of primary estimates with the implementation of the logical operation of disjunction, as well as for the operation of conjunction in the form of a subtractive structure (Fig. 1b). When using femtosecond lasers, which cannot directly generate white light, it is possible to appropriately tune the three primary lasers to colors corresponding to the primary scores.

The output of the optical color architecture is defined as estimates or decisions. The estimates include six gradations, which correspond to the six introduced fuzzy information quanta: red, yellow,

magenta, green, cyan, and blue. Decisions, including those made based on assessments, can be *Yes*, white light *W* or *No*, no light, *Blc*.

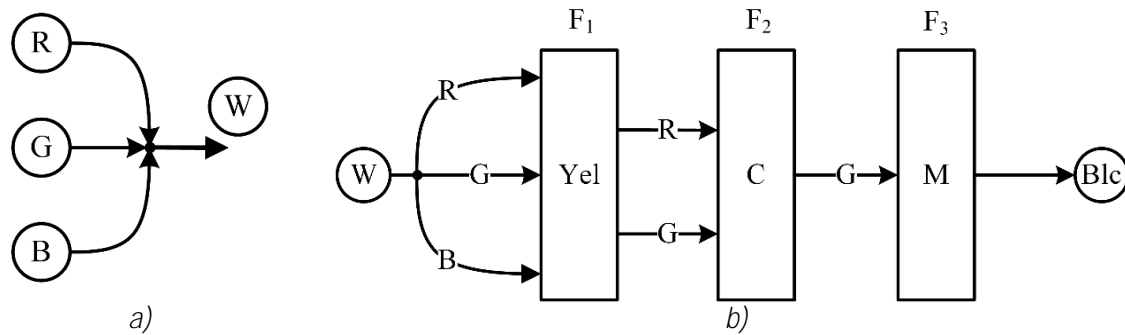

Figure 2: Structural diagrams of elementary coloroids

Visualization of output information does not require additional optical transformations, because the output of the decision-making system is light radiation of a certain color (or its absence for *Blc*), projected onto a certain screen of the human operator.

The work [29], for example, presents a visualization of the output data for a decision-making system when controlling the movement of vessels in limited water areas using the example of the Bug-Dnieper Lyman Canal (Lyman Rybosol, Ukraine).

The system consists of two levels of decision-making: the first level of the hierarchy evaluates the state of the vessel and the environment when entering the canal, and decides to either enter the canal or prohibit it until the input information changes, based on the current assessments of weather conditions and traffic volume in the canal.

The second level evaluates and decides on the possible stopping of the vessel at designated anchorages already while moving along the canal, taking into account the intensity of traffic on a certain dangerous section of the canal.

The human operator receives information about the vessels in the canal and their status in the appropriate color scheme, which helps to quickly intervene if the situation worsens, reacting to the appropriate color combinations on the monitor screen.

A similar system in a more expanded form can be used to control the movement of airliners. The flight control controller will see in a certain color scheme visual information about the movement of many aircraft within the airport's responsibility with a corresponding assessment of the safety of the condition of each aircraft (based on an assessment of the technical condition of the aircraft itself and its crew, and maybe, if necessary, passengers), as well as weather conditions and parameters of the segment of the corresponding trajectory, taking into account its complexity and traffic intensity.

Thus, it becomes possible for the dispatcher to quickly respond to the degree of danger of aircraft movement, without first being distracted by a difficult-to-understand array of technical information.

Another example of visualization is discussed in the work [34], The main idea for the medical field is the combination of color information processing and the use of mobile applications in decision-making processes to increase the information content and efficiency of treatment and care for sick patients.

For a family doctor caring for a group of patients, we offer a special mobile application that generates input data about the patient's condition in the form of information quanta of a certain color.

The input data (12 in total) obviously assess the general condition of the patient at the beginning of the day: temperature, pressure, general condition, condition of individual organs, and the like.

Each color representation of each of the 12 input data assumes, for example, six ratings and a correspondingly specific color: *Very Bad* (high temperature, pressure, etc.) – *red*; *Threatening* – *yellow*; *Alarming* – *magenta*; *More or less normal* – *green*; *Good* – *cyan*; *Very good* – *blue*. The patient enters this color information into their mobile device, receives a summary score, and sends it to the doctor on his/her mobile device. Thus, the doctor sees a generalized color assessment of the condition of his patients at the beginning of the working day.

### 3. Numerical system in color

If it is necessary to encrypt transmitted information, it is of interest to represent color information in the form of numbers. For hybrid color-fuzzy calculations, a circular truth scale [M (-0.25), R (0), Yel (0.25), G (0.5), C (0.75), B (1)] was used when ranking input information [29]. In the context of this section, we are not talking about logical operations, but about simple data transformation.

We use 3 bits to represent binary color. It is natural to assume that the absence of light {Blc} will correspond to

$$[0\ 0\ 0] \rightarrow 0.$$

Further, passing first through the primary colors, starting with R, we obtain

$$[0\ 0\ 1] \rightarrow 1.$$

The second primary color is G

$$[0\ 1\ 0] \rightarrow 2$$

and the next one is Yel, which is the sum of {R} + {G}, which corresponds to

$$[0\ 1\ 1] \rightarrow 3.$$

The next primary color B is

$$[1\ 0\ 0] \rightarrow 4,$$

additional M ({R} + {B}) and C ({B} + {G}) respectively –

$$[1\ 0\ 1] \rightarrow 5$$

and

$$[1\ 1\ 0] \rightarrow 6.$$

And finally, white light W, as the sum of RGB color radiations ({R} + {G} + {B}) will have the value

$$[1\ 1\ 1] \rightarrow 7.$$

Thus, the octal number system was formed.

Another option can be imagined by combining two colors (R and B) in three digits. Then we have

$$N = 2^3 = 8$$

combinations (RRR  $\rightarrow$  1, BBB  $\rightarrow$  2, RBB  $\rightarrow$  3, BRR  $\rightarrow$  4, RRB  $\rightarrow$  5, RBR  $\rightarrow$  6, BRB  $\rightarrow$  7, BBR  $\rightarrow$  8), adding Blc  $\rightarrow$  0 and W  $\rightarrow$  9, we get the decimal number system. We will discover the disadvantage of this representation when transforming the alphabet in the form of repetition of notations while limiting possible combinations.

It should also be noted that if additive and subtractive optical properties of light were used in the construction of the octal system, then the principle of idempotency does not allow the use of optical implementation of the processes of addition and subtraction of colors. Indeed, if we add or subtract, for example, colors, [29]

$$\{B\} + \{B\} = \{B\},$$

$$\{B\} - \{B\} = \{B\},$$

we get {B} that contradicts the addition or subtraction of numbers.

**Table 1**  
**Converting alphabet to numbers**

Color	Set	Number
Black	[0, 0, 0]	0
Red	[0, 0, 1]	1
Green	[0, 1, 0]	2
Yel	[0, 1, 1]	3
Blue	[1, 0, 0]	4
Magenta	[1, 0, 1]	5
Cayn	[1, 1, 0]	6
White	[1, 1, 1]	7

## 4. Alphabet

Suppose we need to translate the alphabet (Latin) and grammar into the language of color. If we consider a 3-bit designation for 3 primary colors, we get  $N = 3^3 = 27$  non-repeating combinations. The Latin alphabet includes 26 letters (one remains in stock), which can be identified as corresponding, rather arbitrarily chosen color combinations.

**Table 2**  
**Converting alphabet to colors**

Serial Number	Letter	Color Set
1	A	RRG
2	B	BBB
3	C	BBG
4	D	GRR
5	E	RRB
6	F	BRR
7	G	RBB
8	H	BRB
9	I	BBR
10	J	GGR
11	K	GRG
12	L	BRG
13	M	RBG
14	N	GRB
15	O	RGB
16	P	GGG
17	Q	GBR
18	R	BGR
19	S	RRR
20	T	RGG
21	U	RBB
22	V	GBG
23	W	BGB
24	X	GGB
25	Y	BGG
26	Z	GBB

Perhaps, for the purpose of convenient memorization and perception, color letters should be arranged in a more optimal sequence (for example, for a keyboard with certain repeatability of the first one predominant color, then the second and third) and compatibility.

The symbol can be represented as a combination of 2 numbers for 3 colors {R,G,B}, giving  $3^2 = 9$  possible combinations, e.g.

“!” → {B,B}; “?” → {R,R}; “=” → {G,G}; “@” → {B,R}

and so on.

For example, the word *Thank* will look, taking into account the notation in Table 2, as follows:

*Thank!* → {RGG BRB RRG GRB GRG} {BB}

## 5. Transformation of optical color information into numerical coding

The subtractive properties of visible light allow us to shape the computing architecture for the transition to numerical calculus. To convert the color calculus of numbers, you can use a coloroid, which includes three parallel light guide channels with filters {B}, {G}, {R}, respectively, in each channel (Fig.3).

The coloroid also contains a block of contacts CB, which reacts to visible light in the corresponding light guide channel (sets the value 1) and determines the place of this branch. The remaining branches give the value 0. The absence of light radiation in each of the branches gives {Blc} and the corresponding values [0 0 0] during encoding. Additional colors {YeI,M,C} have two branches with visible light emission, {W} – three branches.

The input receives a certain color signal corresponding to Table 1. For example, for {R} in the first channel with filter R we will have light radiation, which corresponds to 1; in the second channel with filter G and the third with filter B, light radiation is blocked and absent, which gives 0. Using the matrix form to represent color radiation, we write

$$\begin{aligned} \text{diag}(R, 0, 0) * \text{diag}(0, 0, B) &= \text{diag}(0, 0, 0); \\ \text{diag}(R, 0, 0) * \text{diag}(0, G, 0) &= \text{diag}(0, 0, 0); \end{aligned} \quad (1)$$

$$diag(R, 0, 0) * diag(R, 0, 0) = diag(R, 0, 0).$$

Those. we have a signal at the output [0 0 1].

For the input signal {M} we have

$$\begin{aligned} diag(R, 0, B) * diag(0, 0, B) &= diag(0, 0, B); \\ diag(R, 0, B) * diag(0, G, 0) &= diag(0, 0, 0); \\ diag(R, 0, B) * diag(R, 0, 0) &= diag(R, 0, 0). \end{aligned} \quad (2)$$

Those. we have a signal at the output [1 0 1].

For the input signal {W} we write

$$\begin{aligned} diag(R, G, B) * diag(0, 0, B) &= diag(0, 0, B); \\ diag(R, G, B) * diag(0, G, 0) &= diag(0, G, 0); \\ diag(R, G, B) * diag(R, 0, 0) &= diag(R, 0, 0), \end{aligned} \quad (3)$$

what gives [1 1 1].

Formulas of the form (1-3) can also be written for any other color that represents the corresponding number.

So, for number e.g. "157", we obtain combination [0 0 1]; [1 0 1]; [1 1 1].

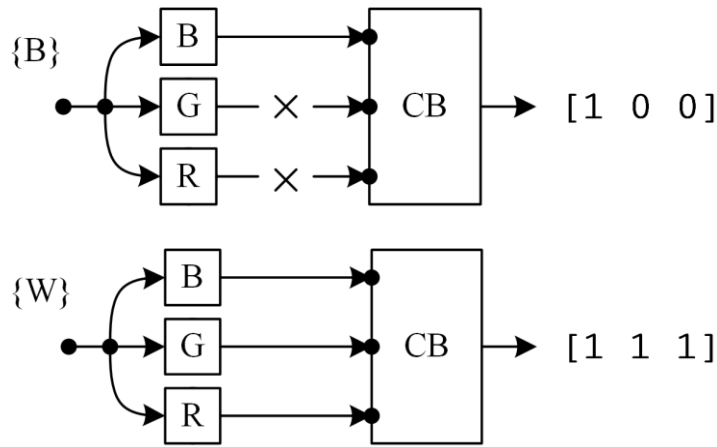

Figure 3: Structural schemes for encoding numbers ({B}, {W})

To convert the color alphabet into a binary code, we use a coloroid, which allows us to pass white light through the color of the corresponding place to identify the code, and then passes for each register through three parallel light channels and turns on the Yel, M, C filters, respectively (Fig. 4., e.g. "Q" → {G,B,R}).

Then for a word, for example, *JOB* {GRR; RGB; BBB}, for the first letter *J* we get {G} in first register:

$$\begin{aligned} diag(0, G, 0) * diag(R, G, 0) &= diag(0, G, 0); \\ diag(0, G, 0) * diag(R, 0, B) &= diag(0, 0, 0); \\ diag(0, G, 0) * diag(0, G, B) &= diag(0, G, 0). \end{aligned} \quad (4)$$

For the first register, we have the combination [1 0 1].

Next, for the second and third registers we obtain for {R}

$$\begin{aligned} diag(R, 0, 0) * diag(R, G, 0) &= diag(R, 0, 0); \\ diag(R, 0, 0) * diag(R, 0, B) &= diag(R, 0, 0); \\ diag(R, 0, 0) * diag(0, G, B) &= diag(0, 0, 0). \end{aligned} \quad (5)$$

So, for the second and third registers we have the same combinations [1 1 0] and [1 1 0]. Thus, the letter *J*, according to formulas (4-5), will have the code [1 1 0; 1 1 0; 1 0 1].

Next, for the second letter *O* {RGB} we get {R} for the first register:

$$\begin{aligned} diag(R, 0, 0) * diag(R, G, 0) &= diag(R, 0, 0); \\ diag(R, 0, 0) * diag(R, 0, B) &= diag(R, 0, 0); \\ diag(R, 0, 0) * diag(0, G, B) &= diag(0, 0, 0). \end{aligned} \quad (6)$$

For the first register, we have the combination [1 1 0].

Next, for the second register, we obtain for {G}

$$\begin{aligned} diag(0, G, 0) * diag(R, G, 0) &= diag(0, G, 0); \\ diag(0, G, 0) * diag(R, 0, B) &= diag(0, 0, 0); \end{aligned} \quad (7)$$



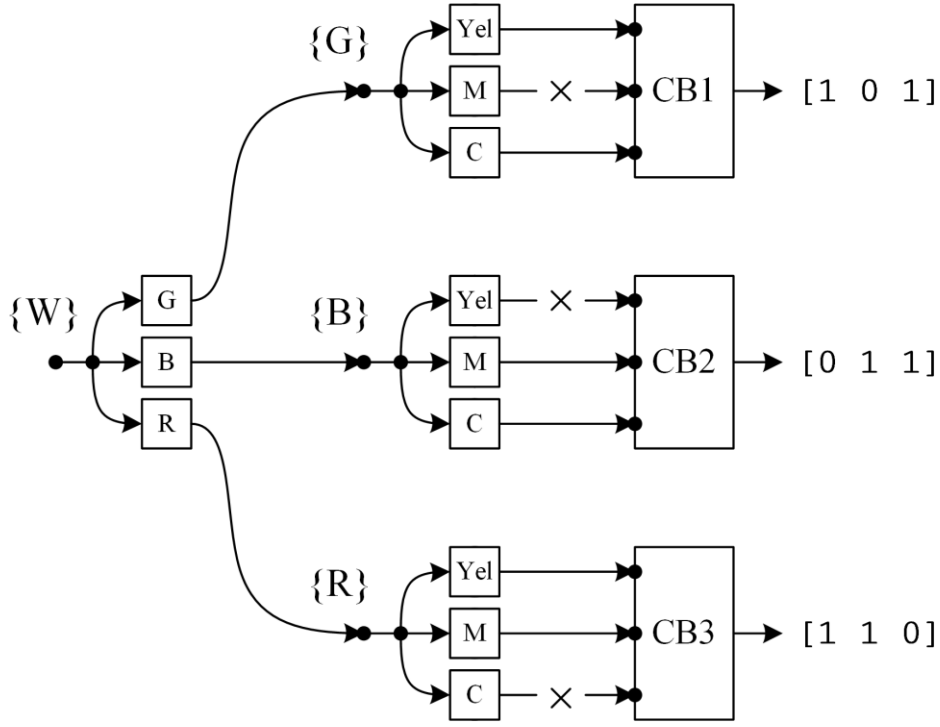

Figure 4: Structural schemes for encoding letters (CB1–CB3 – contact blocks)

$$diag(0, G, 0) * diag(0, G, B) = diag(0, G, 0).$$

For the second register, we have the combination [1 0 1], and third register we obtain for {B}

$$\begin{aligned} diag(0, 0, B) * diag(R, G, 0) &= diag(0, 0, 0); \\ diag(0, 0, B) * diag(R, 0, B) &= diag(0, 0, B); \\ diag(0, 0, B) * diag(0, G, B) &= diag(0, 0, B). \end{aligned} \quad (8)$$

have the combination [0 1 1].

For the third letter B {BBB} we get for the first, second and third registers {B}:

$$\begin{aligned} diag(0, 0, B) * diag(R, G, 0) &= diag(0, 0, 0); \\ diag(0, 0, B) * diag(R, 0, B) &= diag(0, 0, B); \\ diag(0, 0, B) * diag(0, G, B) &= diag(0, 0, B), \end{aligned} \quad (9)$$

we obtain the combination [0 1 1].

We will have, according to formulas (6–9),

$$JOB \rightarrow \{[1 1 0; 1 1 0; 1 0 1]; [1 1 0; 1 0 1; 0 1 1]; [0 1 1; 0 1 1; 0 1 1]\}.$$

Let's define a numeric encoding for the symbol (according to a structure similar to Fig. 4, but with two optical channels), e.g. "@" → {B, R}:

for the first register {B}

$$\begin{aligned} diag(0, 0, B) * diag(R, G, 0) &= diag(0, 0, 0); \\ diag(0, 0, B) * diag(R, 0, B) &= diag(0, 0, B); \\ diag(0, 0, B) * diag(0, G, B) &= diag(0, 0, B), \end{aligned} \quad (10)$$

and second register {R}:

$$\begin{aligned} diag(R, 0, 0) * diag(R, G, 0) &= diag(R, 0, 0); \\ diag(R, 0, 0) * diag(R, 0, B) &= diag(R, 0, 0); \\ diag(R, 0, 0) * diag(0, G, B) &= diag(0, 0, 0). \end{aligned} \quad (11)$$

As a result, according to formulas (10,11), we will have for

$$"@ \rightarrow \{[0 1 1]; [1 1 0]\}.$$

Note that the representation of the color alphabet is not related to optical calculations, but represents identification designations and can be changed according to the necessary algorithms when used, for example, when encrypting information.

It is also quite easy, by implementing the reverse sequence of the coloroid structure, to form a reverse transition from numerical coding to color quanta.

## 6. Discussion of the results

The paper presents the development of a promising approach to representing information in decision support systems as fuzzy color sets (quanta). This makes it possible to create a high-speed optical computing architecture with a fairly simple implementation (without switching) of the basic logical operations of disjunction and conjunction with a wide range of parallel computing capabilities. The analysis [36] of processing efficiency (for example, the addition of fuzzy sets) shows that there are about 700 binary operations per optical operation.

The closest work on the representation of color logical computing is research [19,20,25], however, the implementation of logical operations for binary calculations is carried out according to a difficult-to-implement scheme using printed optical logic elements [19,20], or is aimed at improving the quality of a color display [25].

Of course, the most important and currently unresolved problem in the development of optical color computing is the possibility of technologically advanced nanoscale implementation of optical architecture components. Obviously, this will be a decisive factor when assessing the implementation of optical color structure and competitiveness with other policy approaches. This is, of course, an extremely technologically complex task that requires extensive scientific and industrial research.

Since the authors believe that not all possibilities for using color as a source of information have been explored, this article discusses approaches to color-letter-numeric coding that are easily implemented using optical architecture. The authors believe that this significantly expands the capabilities of this approach not only in the field of information processing but also in its transmission and security.

## 7. Summary

**The presented work proposes directions for expanding the functionality of optical color computing to solve problems in systems with a large amount of input fuzzy information. A unified approach has been formed to the formation of each stage of information processing for decision-making tasks from entering color information with light filters, as well as, if necessary, numerical and text color information, logical inference, visualization and transmission of information both in the form of color quanta and numerical codes.**

Quite simple designs of optical devices have been developed that convert color presentation for numbers and letters into a numeric code. Optical devices (coloroids of a special type) use a system of RGB light filters and blocks of normally closed and normally open contacts to generate the corresponding numeric code in a certain register.

The proposed approach, based on strict physical principles for the formation of optical architecture, provides a fairly simple implementation, while simultaneously demonstrating promising capabilities for high-performance computing and information encryption. The use of light guides easily ensures the implementation of parallel computing structures. Another important advantage of the proposed optical systems is their high resistance to electromagnetic fields, radiation, etc., which is ensured by the physical properties of the optics.

Further development of the architecture of optical color computing should include solving the most important problems in the design of nano-sized components, the development of multi-level inference networks for decision-making systems in areas with big data, such as infrastructure facilities, medicine, and pharmaceuticals, military systems for controlling moving objects, etc.

## References

- [1] The first optical telegraph in Mykolaiv, 2021. URL: [http://www.up.mk.ua/mainpage/show\\_item/68462](http://www.up.mk.ua/mainpage/show_item/68462)
- [2] A. Kotb, Simulation of high quality factor all-optical logic gates based on quantum-dot semiconductor optical amplifier at 1 Tb/s. Optik 127 1 (2016) 320–325. doi.org/10.1016/j.ijleo.2015.10.093

- [3] Y.J. Jung, S. Yu, S. Koo, Reconfigurable all-optical logic AND, NAND, OR, NOR, XOR and XNOR by photonic crystal nonlinear cavities, in: Conference on Lasers and Electro-Optics, Pacific Rim, 2009. doi:10.1109/CLEOPR.2009.5292059
- [4] S. Ma, Z. Chen, N.K. Dutta, All-optical logic gates based on two-photon absorption in semiconductor optical amplifiers, *Optics Communications* 282 23 (2009) 4508-4512. doi.org/10.1016/j.optcom.2009.08.039
- [5] V.. Jandieri, R. Khomeriki, Functional all-optical logic gates for true time-domain signal processing in nonlinear photonic crystal waveguides, *Optics Express* 28 12 (2020) 18317-18331. doi.org/10.1364/OE.395015
- [6] X. Wang, H. Fei, et al., High-performance spiral all-optical logic gate based on topological edge states of valley photonic crystal, 2022. doi.org/10.48550/arXiv.2209.08358
- [7] L. Caballero, M. Povinelli, et al., Photonic crystal integrated logic gates and circuits, *Optics Express*, 30 2 (2022) 1976-1993. doi.org/10.1364/OE.444714
- [8] V. Kreinovich (ed.), *Uncertainty Modeling*, Springer Verlag, Cham, Switzerland, 2017
- [9] C. Qian, X. Lin, et al., Performing optical logic operations by a diffractive neural network, *Light Sci Appl* 9 59 (2020). doi.org/10.1038/s41377-020-0303-2
- [10] Y. Wang, X. Wu, et al., Fuzzy logic based feedback control systems for the frequency stabilization of external-cavity semiconductor lasers, *International Journal of Optomechatronics* 14 1 (2020) 44-51. doi:10.1080/15599612.2020.1828516
- [11] Z. Zhu, J. Yuan, L. Jiang, Multifunctional and multichannels all-optical logic gates based on the in-plane coherent control of localized surface plasmons, *Optics letters* 45 23 2020. 6362-6365. doi:10.1364/OL.402085
- [12] E. Kim, J. Park, J. Kim, S. Kim, Color Decision System based on Deep Learning and Fuzzy Inference System, in: Joint 10th International Conference of Soft Computing and Intelligent, 2018, pp. 236-239. doi:10.1109/SCIS-ISIS.2018.00049
- [13] P.L. McMahon, The physics of optical computing, 2023, arXiv:2308.00088v1, [physics.optics] 2023. doi.org/10.48550/arXiv.2308.00088
- [14] Mu Ku Chen, Xiaoyuan Liu, Yanni Sun, and Din Ping Tsai, *Artificial Intelligence in Meta-optics*, *Chem. Rev.*, 2022, 122, 19, pp. 15356–15413. doi.org/10.1021/acs.chemrev.2c00012
- [15] G. Sharma, M. Vrhel, H. Russell, Color imaging for multimedia, *Processing of IEEE*, 1998, 86 (6), pp. 1088-1108. doi:10.1109/5.687831
- [16] N. Ohta, A.R. Robertson, *Colorimetry. Fundamentals and Applications*, J. Wiley&Sons, 2005.
- [17] M. Ebner, *Color Constancy*, J. Wiley&Sons, 2007.
- [18] A. Koschan, K. Abidi, *Digital Color Image Processing*, J. Wiley&Sons, 2008.
- [19] T. Kawano, Primitive Optical Computing Model with Films: Boolean Conjunction of the Square Matrix-Arrayed Color Codes, *Journal of Advanced Computational Intelligence and Intelligent Informatics*, 17 6 (2013) 791-798. doi: 10.20965/jaciii.2013.p0791
- [20] K. Moritaka, T. Kawano, Use of Colored Reflectors for Negation or Highlighting of Scanned Color Information on Film-Based CIELAB-Coded Optical Logic Gate Models, *Journal of Advanced Computational Intelligence and Intelligent Informatics* 17 6 (2013) 799-804. doi:10.20965/jaciii.2013.p0799
- [21] P.L. Gentili, The fundamental fuzzy logic operators and some complex Boolean logic circuits implemented by the chromogenism of a spirooxazine, *Phys. Chem.* 13 45 (2011) 20335–20344. doi.org/10.1039/C1CP21782H
- [22] P. L. Gentili, A. L. Rightler, B. M. Heron, C. D. Gabbutt, Discriminating between the UV-A, UV-B and UV-C regions by novel Biologically Inspired Photochromic Fuzzy Logic (BIPFUL) systems: A detailed comparative study, *Chemical Engineering, Computer Science, Photochromism, Plant Dyes and Pigments* 135 (2016) 169-176. doi.org/10.1016/j.dyepig.2016.02.034
- [23] K. G., Aby, S. Harpreet, Three-input majority gate using spatially localised DNA hairpins. *Micro & Nano Letters* 12 3 (2017) 143–146. doi:10.1049/mnl.2016.0535

- [24] S. Kato, I. Shinomiya, F. Mori, N. Sugano, Fuzzy Set Theoretical Analysis of Human Membership Values on the Color Triangle, in: Proceedings of the 3rd International Conference on Pattern Recognition Applications and Methods, 2014, pp. 239-246. doi: 10.5220/0004826502390246
- [25] N. Sugano, Fuzzy Set Theoretical Approach to the Tone Triangle System, **International Journal of Software Science and Computational Intelligence** 5 3 (2015) 33-54. doi:10.4018/ijssci.2013070103
- [26] K. M. Iftekharuddin, A. Awwal, Optical computing arithmetic and systems. **Optics & Laser Technology** 32 6 (2000) 389-492. doi.org/10.1016/S0030-3992(00)00105-5
- [27] H. John Caulfield, J. Fu, S. Yoo, Artificial color image logic, *Information Sciences* 167 (2004) 1–7. doi:10.1016/j.ins.2003.09.027
- [28] J. Fu, H. J. Caulfield, S. Yoo, D. Wu, **Fuzzy Aggregation with Artificial Color filters**. *Inf. Sci.*, 180 1 (2010) 167-180. doi.org/10.1016/j.ins.2009.08.014
- [29] V. Timchenko, Yu. Kondratenko, V. Kreinovich, Decision support system for the safety of ship navigation based on optical color logic gates, *CEUR Workshop Proceedings*, 2022, 3347, pp. 42-52.
- [30] V. Timchenko, Yu. Kondratenko, V. Kreinovich, **The Architecture of Optical Logical Coloroid with Fuzzy Computing**, *CEUR Workshop Proceedings*, 2023, 3373, pp. 638-648.
- [31] V. Timchenko, Yu. Kondratenko, V. Kreinovich, Implementation of Optical Logic Gates Based on Color Filters, **Lecture Notes on Data Engineering and Communications Technologies** 181 (2023) 126–136. doi.org/10.1007/978-3-031-36118-0\_12/
- [32] V.L. Timchenko, Y.P. Kondratenko, V. Kreinovich, Why color optical computing?, Book Chapter: *Studies in Computational Intelligence*, Springer 1097 (2023) 227–233. doi.org/10.1007/978-3-031-29447-1\_20
- [33] V.L. Timchenko, Y.P. Kondratenko, V. Kreinovich, Interval-valued and set-valued extensions of discrete fuzzy logics, Belnap logic, and color optical computing, Book Chapter: **Lecture Notes in Computer Science**, Springer (2023) 297-303. doi:10.1007/978-3-031-39965-7\_25
- [34] V.L. Timchenko, V. Kreinovich, Y.P. Kondratenko, Logical Platforms for Mobile Application in Decision Support Systems Based on Color Information Processing, *Journal of Mobile Multimedia* 20 3 (2024) 679-698. doi.org/10.13052/jmm1550-4646.2037
- [35] S. Bennett, Nicholas Minorsky and the automatic steering of ships, **IEEE Control Systems Magazine** 4 4 (1984) 10-15. doi: 10.1109/MCS.1984.1104827
- [36] V.L. Timchenko, V. Kreinovich, Y.P. Kondratenko, V.Y. Horbov, Effectiveness Evaluations of Optical Color Fuzzy Computing, Book Chapter: *Research Tendencies and Prospect Domains for AI Development and Implementation*, River Publishers, Gistrup, Denmark, 2024