

Dear editor, dear reviewer.

Before we proceed with point-by-point addressing of the issues raised by the reviewer, we would like to make a very short synopsis of what was done during this revision.

1. Based on the recommendation of Referee #2, we conducted experiments to test the failure of regional tide gauges. In light of this, we propose changing the title of the manuscript by removing the word "robust" and replacing it with a more descriptive phrase "in the presence of tide gauge sensor failures," so the new title reads: "HIDRA3: deep-learning model for multi-point ensemble sea level forecasting in the presence of tide gauge sensor failures."
2. We have added new sections to the manuscript: 2.4 "*Summary of differences to HIDRA2*," 3.1 "*NEMO model description*," 3.3 "*Uncertainty estimation analysis*," 3.4.2 "*Extreme scenario of a regional tide gauge failure*" and 3.7 "*HIDRA3 limitations*".
3. We have provided additional explanations and figures in the architecture description sections, rewriting Section 2.2.3, "*Feature fusion module*," and Section 2.2.4, "*SSH regression module*."
4. We have included explanations for the data quality check procedures and computation of the tidal signal, expanded the analysis of sea surface temperature and waves' impact on the performance of the model, and corrected some typos.

We proceed to a detailed point-by-point response below.

#### COMMENT 1:

**This study introduces HIDRA3, a deep-learning model developed to estimate multi-point sea levels. It builds upon previous work (Rus et al., 2023), aiming to enhance accuracy and handle missing data. While the research aligns with the scope of this journal and is generally well-written, several unclear aspects need to be addressed before the manuscript can be considered for publication.**

#### RESPONSE 1:

The authors thank the reviewer for their constructive remarks. We have done our best to amend the manuscript according to their suggestions. We respond point by point below.

## COMMENT 2:

### Major Comments:

The major concern is the unclear methodology and application conditions for HIDRA3.

**Page 5, Line 84:** The phrase “detailed manual quality checks” is vague. Does this mean the authors removed data if outliers were detected? How were outliers defined? Is this process feasible in real time? If not, HIDRA3 has only been tested under ideal conditions where manual quality checks have already been applied, which may not be applicable in real-world scenarios. It is essential to clarify what data processing was conducted and if this is possible in real-time. If not, HIDRA3’s performance should be tested on original data without quality checks.

## RESPONSE 2:

We agree with the reviewer that the data-cleaning process is important to the reader. Our data cleaning process addressed three types of errors, all of which could be automatically detected, making real-time implementation feasible. To enable automatic data cleaning, we defined thresholds based on our data-cleaning process and provide detailed descriptions of the data-cleaning steps in the manuscript:

In order to eliminate SSH measurement errors, we apply three filters to address three types of errors: (1) sensor freeze, which results in the same value being produced for an extended period of time; (2) extreme outliers; and (3) extreme jumps in the signals. For case (1), we define a threshold of 5 repetitions, as repetitions typically span more than 5 time points. For case (2), we define a location-specific threshold equal to 10 times the standard deviation of measurements and remove all points that are further away from the mean value than that threshold. Note that the threshold needs to be recalculated after each measurement is removed. For case (3), we examine the first derivative of the signals and define a location-specific threshold equal to 10 times the standard deviation of all first derivatives for some location. When two derivatives with opposite signs are close together (less than 10 time points), the region between them is removed. Again, it is necessary to recalculate the threshold after each removal. The validity of all thresholds was visually verified.

### COMMENT 3:

**Page 5, Line 85: The manuscript suggests that tide data was predicted in one-year intervals. This may lead to “cheating” by using future data for tide predictions. For instance, predicting water levels on June 1, 2019, might involve tide data that includes water levels from that date. In real-world applications, future water level data would not be available. The authors should revise their approach to ensure that tide predictions are made only using available data, rather than yearly-based data.**

### RESPONSE 3:

We thank the reviewer for pointing out this unclarity. We emphasize that the future data *was not used*. The tidal analyses used to compute tidal constituents during each particular year were computed from the past year of tide gauge observations except for the first year. The reason for performing tidal analysis in one-year chunks stems from the fact that tidal signals contain several low-frequency signals, most notably an 18.6-year cycle of the precession of lunar nodes. This leads to a slow oscillation in amplitudes and phases of tidal constituents. A classical approach to remedy this situation when computing tides from observations is to compute them in one-year chunks (see e.g. [https://doi.org/10.1016/S0098-3004\(02\)00013-4](https://doi.org/10.1016/S0098-3004(02)00013-4)). An alternative for longer time windows is to employ nodal corrections or perform analyses on series of sufficient length to resolve all necessary low frequency constituents. To address the reviewer’s concern, we add the following text to the manuscript:

Astronomic tides were calculated from tide gauge data in one-year intervals using the UTIDE Tidal Analysis package for Python (Codiga, 2011). Using one year intervals for tidal analysis are common approach to compensate for the unresolved low frequency signals in the tidal signal, like the 18.6 year oscillation due to the precession of lunar nodes (Pawlowicz et al., 2002). For each one-year interval, tidal constituents are inferred from the past year of observations to ensure that no information beyond the prediction point is used. The only exception is in the first year of measurements for each location, when the first year of measurements is used to calculate the first year of tides. This approach is beneficial for training the model and does not affect the evaluation data, as all tide gauges have measurements spanning at least one year prior to the test period.

#### COMMENT 4:

**Page 5, Line 93: The reason for using ERA5 for training and ECMWF for testing is unclear. If the model trained with ERA5 outperforms the model trained with ECMWF, the authors should clearly present this result. Otherwise, the choice to use ERA5 for training is unjustified.**

#### RESPONSE 4:

We thank the reviewer for this comment. We have experimented with training using both ERA5 and ECMWF prediction data, and we discovered that training with ERA5 slightly enhances performance on the test set. This is why we decided to train with ERA5. We include a sentence in the manuscript to demonstrate this improvement:

ERA5 reanalysis data (Hersbach et al., 2018) was employed for training purposes, while ECMWF Ensemble Prediction System (EPS) data (Leutbecher and Palmer, 2007) was employed for evaluation to reflect the practical forecasting setup in which future reanalysis does not exist and forecasts are used. To independently verify the impact of the training set, HIDRA3 was also retrained on ECMWF EPS data instead of ERA5. When evaluated on the ECMWF EPS dataset, this led to a slight increase in MAE (1.7%). We consequently decided to select the ERA5 dataset for the training.

#### COMMENT 5:

**Page 7, Line 119: HIDRA3 incorporates additional features (sea surface temperature and waves) compared to HIDRA2, but this is not clearly stated. The manuscript should explain why these features were included. Although Section 3.4.2 discusses their impact, it does not analyze their individual contributions. The authors should reference feature selection studies and test the impact of each new feature (sea surface temperature and waves) to justify their inclusion.**

#### RESPONSE 5:

We thank the reviewer for their suggestion. We have added two ablation studies to Section 3.6.2 "*Impact of sea temperature and waves*," in which we test the individual contributions of waves and sea surface temperature. From the experiments, it is difficult to conclusively state which feature contributes more, but it is nevertheless clear, that adding them slightly improves the performance. The revised Section 3.6.2, "*Impact of sea temperature and waves*," now reads as follows:

##### **3.6.2 Impact of sea temperature and waves**

To evaluate the importance of using sea surface temperature and wave data to enhance our model, we retrained HIDRA3 by these variables ablated. We first removed only sea surface temperature, which resulted in an average 1.7% increase in the overall MAE and a 1.2% increase in the MAE on high SSHs. Next, we removed only wave data, which led to an average 1.2% increase in the overall MAE and a 2.4% increase in the MAE on high SSHs. Finally, in the third experiment, we removed both sea surface temperature and wave data, which caused an average 0.8% increase in the overall MAE and a 2.7% increase in the MAE on high SSHs. These results suggest that sea surface temperature and wave data are not the main sources of the HIDRA3's excellent performance, however, they do bring a non-negligible contribution and we recommend using them in the SSH prediction tasks.

COMMENT 6:

**Sections 2.2.3 and 2.2.4: It is unclear how missing data (denoted as  $x_i$ ) is handled. Page 9, Line 150 mentions that missing values are estimated from “ $s$ ,” but it is unclear what “ $s$ ” refers to. The authors need to clarify what the feature fusion module is doing and explain the difference between  $x_i$  and  $s$ , preferably with a figure for better understanding.**

RESPONSE 6:

We thank the reviewer for this comment. We agree that the explanation of how missing values are handled is not clear. In the Feature Fusion module, location-specific features “ $x_i$ ” from only tide gauges with available measurements are combined into “ $s$ ”. We rewrite Section 2.2.3 “*Feature fusion module*” and include figures to clearly illustrate this process, as well as the reasons for passing “ $x_i$ ” to the SSH regression module.

### 2.2.3 Feature fusion module

As indicated in Fig. 4, the feature fusion module combines the location-specific features  $\mathbf{x}_i \in \mathbb{R}^{1024}$ , into a joint state vector  $\mathbf{s} \in \mathbb{R}^{8192}$ . A critical design requirement for the module is robustness to missing data; specifically, the number of location-specific features  $\mathbf{x}_i$  may vary, as they are only available for the tide gauges with available measurements.

Firstly, a partial reconstruction  $\mathbf{s}_i$  of the state is computed from each location-specific feature vector  $\mathbf{x}_i$  by applying a location-specific dense layer (see Fig. 8). In addition, a weight vector  $\mathbf{w}_i$  is computed by applying another location-specific dense layer to  $\mathbf{x}_i$ . Each coordinate in  $\mathbf{w}_i$  reflects the extent by which the particular location contributes to the respective coordinate in the joint state vector. If some tide gauges are non-descriptive, their weights would be reduced during training, lowering their influence on the final state vector  $\mathbf{s}$ , which is thus computed as

$$\mathbf{s} = \sum_{i \in V} \hat{\mathbf{w}}_i \odot \mathbf{s}_i, \quad (1)$$

where  $\odot$  denotes element-wise array multiplication,  $\hat{\mathbf{w}}_i$  are the coordinate-normalized weight vectors and  $V$  contains indices of tide gauges with available SSH measurements, so that  $\mathbf{s}$  is approximated from tide gauges with available measurements. The components  $\hat{w}_{i,j}$  are defined computed using softmax function:

$$\hat{w}_{i,j} = \frac{e^{w_{i,j}}}{\sum_{k \in V} e^{w_{k,j}}}, \quad (2)$$

where the softmax ensures that the coordinate-wise weights sum to one across all locations with available measurements.

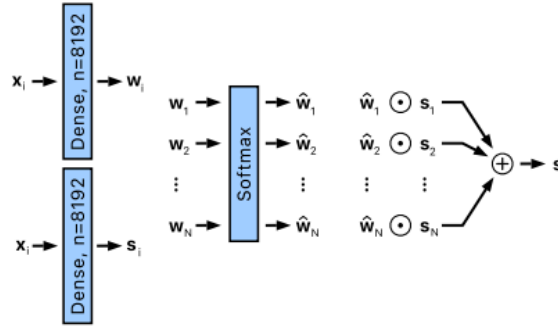

**Figure 8.** The Feature Fusion Module takes features  $x_i$  from location  $i$  and uses them to generate weights  $w_i$  and a partial reconstruction of state  $s_i$ . These weights and partial reconstructions are combined into a joint state vector  $s$  using weighting and aggregation mechanisms. Locations without available measurements are excluded from the softmax calculation and aggregation. The parameters of the dense layers are specific to each location. The element-wise multiplication is denoted by the symbol  $\odot$ .

COMMENT 7:

**Page 11, Line 191: The differences between HIDRA2, NEMO, and HIDRA3 are not adequately explained. It would be helpful for the authors to provide a clear comparison of these models. For example, HIDRA2 does not consider temperature and wave data. Both HIDRA2 and HIDRA3 are designed for 72-hour predictions. NEMO, on the other hand, performs bias correction every 12 hours. Clarifying these differences would strengthen the manuscript.**

RESPONSE 7:

We thank the reviewer for pointing this out. We have provided a detailed description of NEMO in Section 3.1, titled "*NEMO model description*," and outlined the differences between HIDRA2 and HIDRA3 in Section 2.4, "*Summary of differences to HIDRA2*." Both are included below.

#### **2.4 Summary of differences to HIDRA2**

HIDRA3 presents a significant advancement over its predecessor, HIDRA2 (Rus et al., 2023), by introducing the capability to simultaneously process data from multiple tide gauge locations. This required a major redesign of the model, as HIDRA3 must effectively handle scenarios where SSH measurements are not available.

The only similar part is the Geophysical encoder module, but with a difference in the way temporal data is processed. In HIDRA2, there is a 4-hour temporal reduction of atmospheric data, while HIDRA3 incorporates the temporal reduction directly into the convolutional operations of the Geophysical encoder module. Additionally, HIDRA3 expands its input data to include sea surface temperature and wave fields, and considers not only the past 24 hours like HIDRA2, but 72 hours before the prediction point.

A notable contribution of HIDRA3 is its capacity for uncertainty quantification, a feature that was absent in HIDRA2. This capability is crucial for assessing the reliability and potential limitations of the SSH forecasts generated by the model.

### 3.1 NEMO model description

We compare HIDRA3 with the state-of-the-art deep model HIDRA2 (Rus et al., 2023) and with the standard Copernicus Marine Environment Monitoring Service (CMEMS) product MEDSEA\_ANALYSISFORECAST\_PHY\_006\_013 (Clementi et al., 2021) numerical model Nucleus for European Modelling of the Ocean (NEMO) v4.2 (Madec, 2016). The Mediterranean Sea Physical Analysis and Forecasting model (MEDSEA\_ANALYSISFORECAST\_PHY\_006\_013) operates on a regular grid with a horizontal resolution of  $1/24^\circ$  (approximately 4 km) and 141 vertical levels. It uses a staggered Arakawa C-grid with masking for land areas, and a  $z^*$  vertical coordinate system with partial cells to accurately represent the model topography. The model incorporates tidal forcing using eight components (M2, S2, N2, K2, K1, O1, P1, Q1) and is forced at its boundaries by the Global analysis and forecast product (GLOBAL\_ANALYSISFORECAST\_PHY\_001\_024) on the Atlantic side, while in the Dardanelles Strait, it uses a combination of daily climatological fields from a Marmara Sea model and the global analysis product. Atmospheric forcing comes from ECMWF forecasting product. Initial conditions are taken from the World Ocean Atlas (WOA) 2013 V2 winter climatology as of January 1, 2015. Data assimilation is performed using the OceanVar (3DVAR) scheme, which integrates in-situ vertical profiles of temperature and salinity from ARGO, Glider, and XBT, as well as Sea Level Anomaly (SLA) data from multiple satellites (including Jason 2 & 3, Saral-Altika, Cryosat, Sentinel-3A/3B, Sentinel6A, and HY-2A/B). The hydrodynamic part of the model is coupled to the wave model WaveWatch-III. Further information about the model is available in Clementi et al. (2021).

Since NEMO predicts the full ocean state, including SSH, on a regular grid, the respective tide gauge locations are approximated by the nearest-neighbor locations in the grid. One important thing to note is that ocean models like NEMO calculate sea surface height as a local departure from the geoid in the computational cell. A typical cell dimension is of the order of hundreds of meters. This means that the model's SSH represents a departure from the geoid, averaged over hundreds of squared meters, and is not directly relatable to the in-situ observations from local tide gauges, which measure local water depth. Therefore, to align NEMO forecasts with local tide gauge water depth, an offset adjustment of the initial 12-hour forecast is necessary to ensure zero bias compared to the respective tide gauge, as explained in Rus et al. (2023).

COMMENT 8:

Tables 2, 3, and 4: It is unclear why the recall, precision, and F1 scores for “low SSH values” are missing. Low water level predictions are important, particularly for critical infrastructure like nuclear power plants or harbors. The authors should explain why these metrics are missing and include them if possible.

RESPONSE 8:

We agree with the reviewer that there is no reason not to include recall, precision, and F1 scores for low SSH values. We computed the metrics and added them to the tables:

	Model	MAE (cm)	RMSE (cm)	ACC (%)	Bias (cm)	Re (%)	Pr (%)	F1 (%)
Overall	NEMO	2.65	3.56	97.76	-0.31	/	/	/
	HIDRA2	2.63	3.56	98.15	-0.17	/	/	/
	HIDRA3 (ours)	<b>2.42</b>	<b>3.28</b>	<b>98.60</b>	<b>-0.00</b>	/	/	/
Low SSH Values	NEMO	4.19	5.23	92.91	2.88	94.04	<b>99.92</b>	96.39
	HIDRA2	<b>3.27</b>	4.27	95.94	<b>1.02</b>	97.64	99.55	98.51
	HIDRA3 (ours)	3.30	<b>4.24</b>	<b>96.16</b>	1.33	<b>98.04</b>	99.85	<b>98.88</b>
High SSH Values	NEMO	4.68	6.19	89.14	-3.02	94.53	<b>99.40</b>	96.79
	HIDRA2	4.80	6.53	89.49	-2.35	96.62	97.82	97.18
	HIDRA3 (ours)	<b>4.06</b>	<b>5.61</b>	<b>91.63</b>	<b>-2.06</b>	<b>97.58</b>	98.67	<b>98.09</b>

**Table 2.** Performance calculated on all SSH values, low SSH values and high SSH values, averaged over all locations. The proposed HIDRA3 has the best performance overall and on high SSH values, and a comparable performance on low values to HIDRA2.

	Model	MAE (cm)	RMSE (cm)	ACC (%)	Bias (cm)	Re (%)	Pr (%)	F1 (%)
Overall	NEMO <sub>0</sub>	3.26	4.15	95.81	<b>0.03</b>	/	/	/
	HIDRA3 (ours)	<b>2.63</b>	<b>3.52</b>	<b>98.35</b>	-0.07	/	/	/
Low SSH Values	NEMO <sub>0</sub>	4.00	4.95	<b>96.00</b>	3.08	97.41	<b>99.55</b>	98.44
	HIDRA3 (ours)	<b>3.30</b>	<b>4.26</b>	95.75	<b>1.02</b>	<b>98.23</b>	99.51	<b>98.82</b>
High SSH Values	NEMO <sub>0</sub>	5.12	6.48	86.82	-2.96	92.20	<b>99.81</b>	95.24
	HIDRA3 (ours)	<b>4.46</b>	<b>6.04</b>	<b>89.94</b>	<b>-2.32</b>	<b>97.38</b>	98.81	<b>98.06</b>

**Table 3.** Performance of HIDRA3 and NEMO<sub>0</sub> under the target location tide gauge failure.

	Model	MAE (cm)	RMSE (cm)	ACC (%)	Bias (cm)	Re (%)	Pr (%)	F1 (%)
Overall	NEMO	2.65	3.56	97.76	-0.31	/	/	/
	HIDRA2	2.63	3.56	98.15	-0.17	/	/	/
	HIDRA3 <sub>1</sub> (ours)	<b>2.60</b>	<b>3.47</b>	<b>98.40</b>	<b>0.02</b>	/	/	/
Low SSH Values	NEMO	4.19	5.23	92.91	2.88	94.04	<b>99.92</b>	96.39
	HIDRA2	<b>3.27</b>	<b>4.27</b>	<b>95.94</b>	<b>1.02</b>	<b>97.64</b>	99.55	<b>98.51</b>
	HIDRA3 <sub>1</sub> (ours)	3.52	4.47	95.58	1.79	97.31	99.21	98.16
High SSH Values	NEMO	4.68	6.19	89.14	-3.02	94.53	<b>99.40</b>	96.79
	HIDRA2	4.80	6.53	89.49	-2.35	96.62	97.82	97.18
	HIDRA3 <sub>1</sub> (ours)	<b>4.34</b>	<b>5.98</b>	<b>90.94</b>	<b>-1.72</b>	<b>96.82</b>	98.54	<b>97.65</b>

**Table 4.** Performance of NEMO, HIDRA2 and HIDRA3<sub>1</sub>, where HIDRA3<sub>1</sub> is the model trained separately on every single location.



## COMMENT 9:

**Figure 11: The manuscript only considers “pair” failures for tide gauges, but more realistic scenarios should be explored. For instance, a failure involving multiple tide stations, such as in the northern Adriatic (KP, VE, RA), where water levels show similar trends (as per Figure 2), would offer a more realistic test of HIDRA3’s performance. Testing such scenarios would strengthen the justification for using HIDRA3 over other approaches.**

## RESPONSE 9:

We thank the reviewer for this excellent experiment, in which we simulated the complete failure of all tide gauges in Koper, Venice, and Ravenna. The results of the experiment demonstrate that HIDRA3 remains robust in the case of regional tide gauge failure, with only a slight downgrade in performance observed for the northern locations due to the removed measurements. The results of this experiment are detailed in Section 3.4.2 of the revised manuscript, titled *“Extreme scenario of a regional tide gauge failure:”*

### 3.4.2 Extreme scenario of a regional tide gauge failure

To evaluate the model’s performance under an extreme scenario of a regional tide gauge failure, we conducted an additional experiment where all northern locations (Koper, Venice, and Ravenna) were disabled. These locations exhibit distinct dynamical characteristics compared to others, as illustrated in Figures 2 and 3. The evaluation of HIDRA3 without SSH measurements from Koper, Venice, and Ravenna is denoted as HIDRA3<sub>S</sub>. Importantly, the model was not retrained for this experiment; rather, the same model trained on all locations was used, with the specified measurements withheld from the test set. This stress test quantifies HIDRA3 predictions for northern tide gauges based exclusively on data from southern tide gauges.

Figure 17 compares the MAE scores of HIDRA3<sub>S</sub>, HIDRA3, and NEMO. Surprisingly, HIDRA3<sub>S</sub> demonstrates robust forecasting capabilities in the northern locations, despite lacking direct measurements. While the MAE scores are slightly higher than those obtained with all locations as inputs (HIDRA3), they significantly outperform NEMO. In the southern locations, the performance of HIDRA3 and HIDRA3<sub>S</sub> is comparable and worse than NEMO. This is expected given the availability of past SSH measurements for these regions.

We plot the performance during multiple tide gauge failure in a separate Figure:

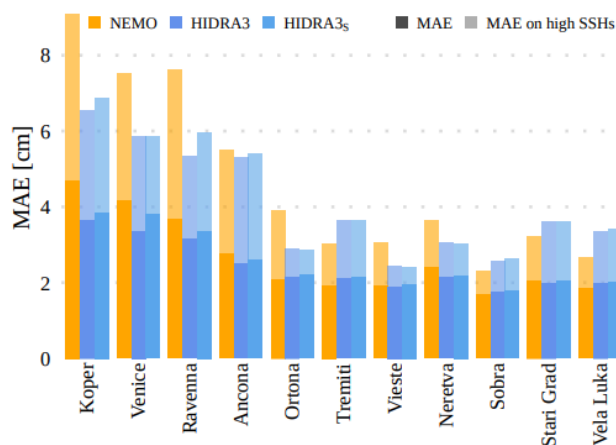

**Figure 17.** Multiple sensor failure scenario. Overall (dark) and high SSH (light) MAE scores for NEMO, HIDRA3, and HIDRA3<sub>S</sub>. HIDRA3<sub>S</sub> represents the evaluation of HIDRA3 with only southern locations as input, excluding sensors in Koper, Venice, and Ravenna.

We also add a sentence to the Abstract:

respectively, setting a solid new state-of-the-art. [Forecasting skill does not deteriorate even in the case of simultaneous failure of multiple sensors in the basin or when predicting solely from the tide gauges far outside the Rossby radius of a failed sensor.](#) Furthermore, HIDRA3 shows remarkable performance at substantially smaller amounts of training data compared with HIDRA2, making it appropriate for sea level forecasting in basins with large regional variability in the available tide gauge data.

COMMENT 10:

**There is no dedicated section on the limitations of HIDRA3. For example, HIDRA3 does not work if data from at least one station is missing for the 72-hour prediction window. The limitations should be clearly stated.**

RESPONSE 10:

To ensure a comprehensive understanding of HIDRA3's capabilities and limitations, we have added a dedicated section to our paper that outlines the specific conditions under which the model may encounter challenges:

### **3.7 HIDRA3 limitations**

HIDRA3 can generate forecasts for all locations even if the data from some locations is missing, which is a substantial improvement over its predecessor, HIDRA2. The current implementation of HIDRA3 disregards the entire 72-hour SSH dataset from the previous three days if even a single value of SSH is missing. This might be an overly stringent criterion and we are working to find optimal ways to address this. Furthermore, in a highly unlikely situation when the sensors at *all locations* would fail and the data would be missing for the full 72 h past period, HIDRA3 could not generate forecasts reliably. In this case, a potential solution of using the past HIDRA3 prediction as the input for the current prediction is still applicable. Preliminary simulations of such scenarios indicate that the MAE of HIDRA3 increases by 35% overall and by 43% for high SSH values. Additional work, however, needs to be performed to further constrain HIDRA3 behavior in such scenarios.

COMMENT 11:

**Minor Comments:**

**Page 3, Line 45: The full name of HIDRA should be provided.**

RESPONSE 11:

Thank you. The text was corrected as suggested.

COMMENT 12:

**Page 3, Line 60: The authors should expand their literature review to include studies that address missing data in real time, such as Lee and Park (2016) and Vieira et al. (2020), for better context.**

RESPONSE 12:

We thank the reviewer for suggesting the relevant articles by Lee and Park (2016) and Vieira et al. (2020). We expand our literature review to include these contributions.

COMMENT 13:

**Page 5, Line 86-89: It would be helpful to clarify where the “high” and “low” data will be used in the next section. As written, the reason for defining “high” and “low” is unclear.**

RESPONSE 13:

We thank the reviewer for this suggestion. We now explicitly mention that we use these data in evaluation in the appropriate Section and we also list why this is relevant to know. The new paragraph now reads:

In the context of this analysis, a dataset of sea-level extremes was constructed for each station. SSH readings are categorized as *low* if they are below the 1<sup>st</sup> percentile, and as *high* if they surpass the 99<sup>th</sup> percentile of the observed values at the respective location. During evaluation (Sect. 3.2), metrics are calculated for all SSH values, as well as for low and high values. This helps assess the model’s performance in predicting both tails of extreme SSH values: high values are relevant for coastal flood warnings while low values restrict marine traffic in the shallow north of the basin. The thresholds determined are listed in Table 1.

COMMENT 14:

**Figure 2 and Page 5, Line 89: The location names in Figure 2 and the acronyms used in the text should be consistent for readability.**

RESPONSE 14:

As the reviewer suggested, we updated the text to include the full names of the locations.

COMMENT 15:

**Figure 5 and Page 7, Line 118: The output dimensions are different for various features (e.g., wind and pressure have different dimensions compared to others). The caption for Figure 5 should be corrected to reflect these differences.**

RESPONSE 15:

We thank the reviewer for noticing this, we changed the caption as follows:

**Figure 5.** The first step of the Geophysical encoder module involves encoding each of the four variables separately. Note that wind has two input channels, while the waves data has four. The encoder consists of two 3D convolutions, reducing spatial dimension to  $1 \times 1$ . Wind and pressure are encoded into 512 output channels, as depicted in the figure, while sea surface temperature and wave data are encoded into 64 channels. The variables  $k$ ,  $s$  and  $n$  denote the kernel size, the stride and the number of output channels, respectively. The number of channels is indicated in gray, the size of the temporal dimension is in red, and the spatial dimensions are in blue.

COMMENT 16:

**Figure 6: The authors should explain why the input dimension is  $1152 \times 36$ , given that the output dimension of Figure 5 is  $512 \times 36 \times 1 \times 1$ . The change in dimensions needs clarification.**

RESPONSE 16:

To address the reviewer's concern, we add the following explanation to the revised manuscript:

Encodings from all variables are concatenated, resulting in a total of  $2 \cdot 512 + 2 \cdot 64 = 1152$  channels. By removing spatial dimensions of size 1, concatenation is of size  $1152 \times 36$ , which is then in the second step of the Geophysical encoder (see Fig. 6) processed by a 1D convolution with 256 kernels of temporal size 5. We have chosen the kernel size of 5 to increase

COMMENT 17:

**Figures 6 and 7: The terms "2X" and "4X" should be explained, as their meaning is unclear.**

RESPONSE 17:

As suggested, we added the explanations.

COMMENT 18:

Page 8, Line 130: The authors mention a “dense layer,” but later refer to “dropout” in Figure 7. This needs clarification, as dropout is not typically associated with fully connected layers.

RESPONSE 18:

After the first dense layer mentioned in Line 130, we do not apply Dropout. However, after dense layers with residual connections, we do apply Dropout. We add dropout to prevent overfitting, and we have added this information to the manuscript. We hope we have addressed the reviewers' concerns.

COMMENT 19:

Section 2.2.3 and 2.2.4: Including a diagram, similar to Figure 6, would help readers understand the concepts better.

RESPONSE 19:

AS suggested, we added the following diagrams:

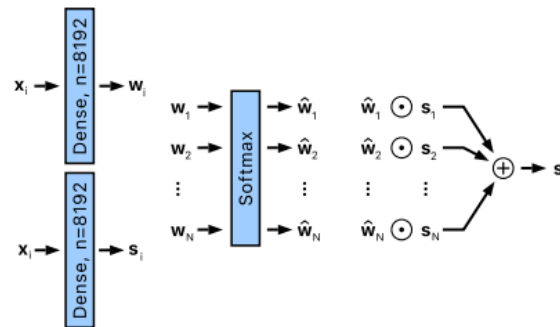

**Figure 8.** The Feature Fusion Module takes features  $x_i$  from location  $i$  and uses them to generate weights  $w_i$  and a partial reconstruction of state  $s_i$ . These weights and partial reconstructions are combined into a joint state vector  $s$  using weighting and aggregation mechanisms. Locations without available measurements are excluded from the softmax calculation and aggregation. The parameters of the dense layers are specific to each location. The element-wise multiplication is denoted by the symbol  $\odot$ .

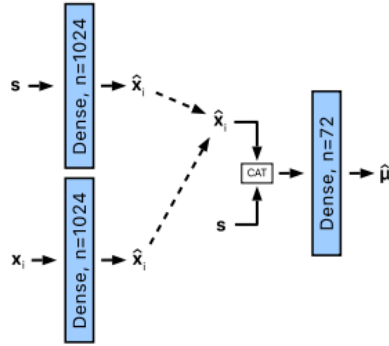

**Figure 9.** The SSH regression module for a location  $i$  receives joint state vector  $\mathbf{s}$  and location-specific features  $\mathbf{x}_i$ . The features  $\mathbf{x}_i$  are processed by a dense layer to produce the features  $\hat{\mathbf{x}}_i$ . In cases where measurements from the tide gauge at location  $i$  are unavailable, and therefore  $\mathbf{x}_i$  is undefined,  $\hat{\mathbf{x}}_i$  is approximated from  $\mathbf{s}$  using a separate dense layer. The features  $\hat{\mathbf{x}}_i$  and  $\mathbf{s}$  are then concatenated and passed through a final dense layer to obtain SSH predictions, denoted as  $\hat{\mu}_i$ .

COMMENT 20:

**Page 9, Line 158: The term “mean” in “SSH mean value prediction” is unclear. The authors should clarify whether this is a typo or explain its meaning.**

RESPONSE 20:

We thank the reviewer for spotting this. It is a typo and we corrected it in the revision.

COMMENT 21:

**Page 10, Line 163: The standardization process needs further explanation. Was the data normalized for each case or across the entire dataset?**

RESPONSE 21:

The geophysical variables are standardized independently, while the tide gauges share the standard deviation used for their normalization. We add the following text in the revised manuscript to reflect this:

probability of 0.5. The batch size is set to 128 data samples, the model is trained for 20 epochs. All input data is standardized by subtracting the mean and dividing by the standard deviation. For each tide gauge location, the mean is calculated independently, while a single standard deviation is computed across all locations. Each geophysical variable is standardized independently of the other variables. Training takes approximately one hour on a computer with an NVIDIA A100 Tensor Core GPU graphics card.

COMMENT 22:

**Page 10, Line 170: For consistency, the term “first stage” should be replaced with “first phase.”**

RESPONSE 22:

Thank you for your suggestion. We replaced "first stage" with "first phase."

COMMENT 23:

**Page 11, Line 193: The full name of NEMO should be provided.**

RESPONSE 23:

As suggested, we added the name: “Nucleus for European Modeling of the Ocean.”