

Amendment to the Customs Convention on the International Transport of Goods Under the Cover of TIR Carnets (TIR Convention, 1975)

According to the UN Depository Notification C.N.742.2016.TREATIES — XI.A.16 the following amendments to the TIR Convention enter into force on 1 January 2017 for all Contracting Parties:

Annex 6, new Explanatory Note 0.42 bis:

Add a new Explanatory Note to Article 42 bis to read as follows:

'0.42 bis The term "immediately" in Article 42 bis is understood to mean that national measures that may affect the application of the TIR Convention and/or functioning of the TIR system, ought to be communicated in writing to the TIR Executive Board (TIRExB) as soon as possible and, if possible, prior to their entry into force, so as to allow TIRExB to efficiently discharge its supervisory functions and fulfil its responsibility to examine the measure as to its conformity with the TIR Convention in accordance with Article 42 bis and its Terms of Reference as laid down in Annex 8 of the TIR Convention.'

Annex 2, Article 4, paragraph 2(i):

For the existing text substitute:

'(i) The sliding sheets, floor, doors and all other constituent parts of the load compartment shall be assembled either by means of devices which cannot be removed and replaced from the outside without leaving obvious traces, or by such methods as will produce a structure which cannot be modified without leaving obvious traces.'

Annex 2, Article 4, paragraph 2(iii):

For the existing text substitute:

'(iii) The sliding sheet guidance, sliding sheet tension devices and other movable parts shall be assembled in such a way that when closed, and Customs sealed, doors and other movable parts cannot be opened or closed from the outside without leaving obvious traces. The sliding sheet guidance, sliding sheet tension devices and other movable parts shall be assembled in such a way that it is impossible to gain access to the load compartment without leaving obvious traces once the closing devices have been secured. An example of such a system of construction is given in sketch No 9 appended to these Regulations.'

Annex 2, new Article 5:

After the modified Article 4 insert:

'Article 5

Vehicles with a sheeted sliding roof

1. Where applicable, the provisions of Articles 1, 2, 3 and 4 of these Regulations shall apply to vehicles with a sheeted sliding roof. In addition, these vehicles shall conform to the provisions of this Article.
2. The sheeted sliding roof shall fulfil the requirements set out in (i) to (iii) below.
 - (i) The sheeted sliding roof shall be assembled either by means of devices which cannot be removed and replaced from the outside without leaving obvious traces, or by such methods as will produce a structure which cannot be modified without leaving obvious traces.
 - (ii) The sliding roof sheet shall overlap with the solid part of the roof at the front side of the load compartment, so that the roof sheet cannot be pulled over the top edge of the upper cantrail. In the length of the load compartment, at both sides, in the hem of the roof sheet, a pre-stressed steel cable shall be inserted in such a way that it cannot be removed and re-inserted without leaving obvious traces. The roof sheet shall be secured to the sliding carriage in such a way that it cannot be removed and re-secured without leaving obvious traces.

- (iii) The sliding roof guidance, the sliding roof tension devices and other movable parts shall be assembled in such a way that when closed, and Customs sealed, doors, roof and other movable parts cannot be opened or closed from the outside without leaving obvious traces. The sliding roof guidance, sliding roof tension devices and other movable parts shall be assembled in such a way that it is impossible to gain access to the load compartment without leaving obvious traces once the closing devices have been secured.

An example of a possible system of construction is shown in sketch No 10, appended to these Regulations.’

Annex 2, Sketch No 9:

For the existing Sketch No 9 substitute:

‘Sketch No 9

EXAMPLE OF A CONSTRUCTION OF A VEHICLE WITH SLIDING SHEETS

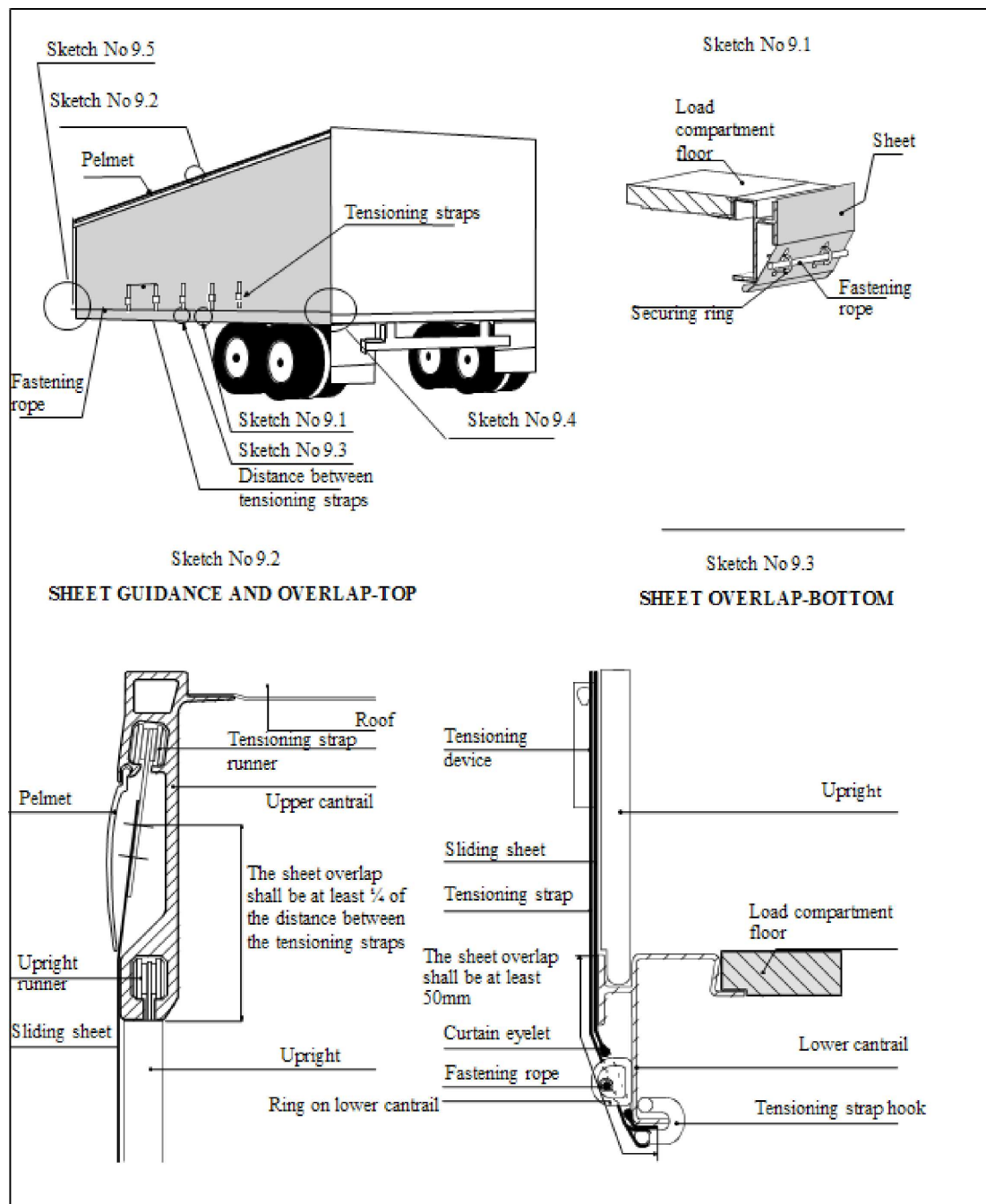

Sketch No 9 continued

Sketch No 9.4

To tighten the sliding sheets in the horizontal direction, a ratchet gear is used (normally at the rear end of the vehicle). This sketch shows two examples, (a) and (b), of how the ratchet or gearbox may be secured.

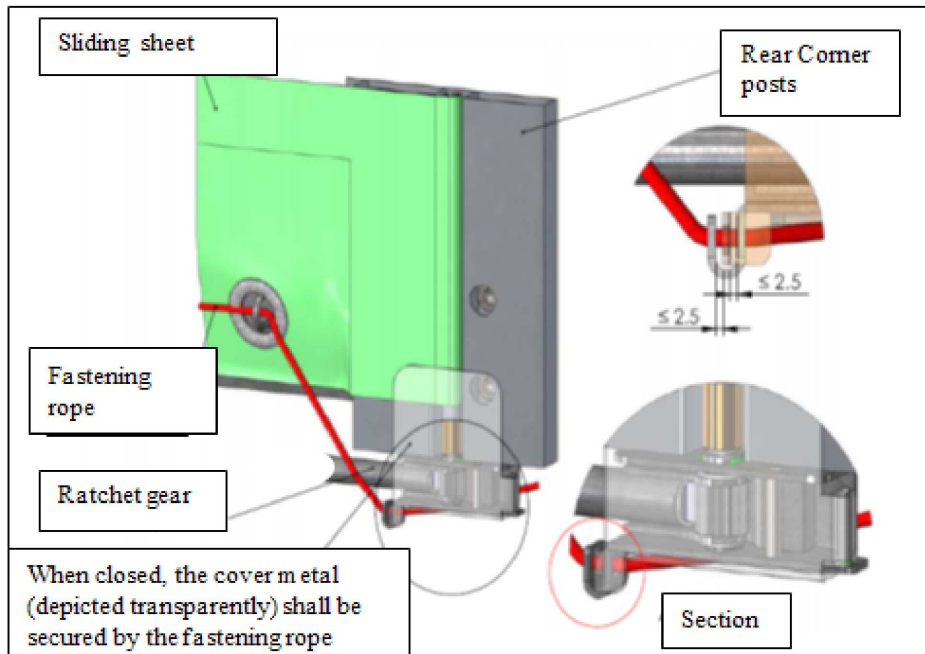
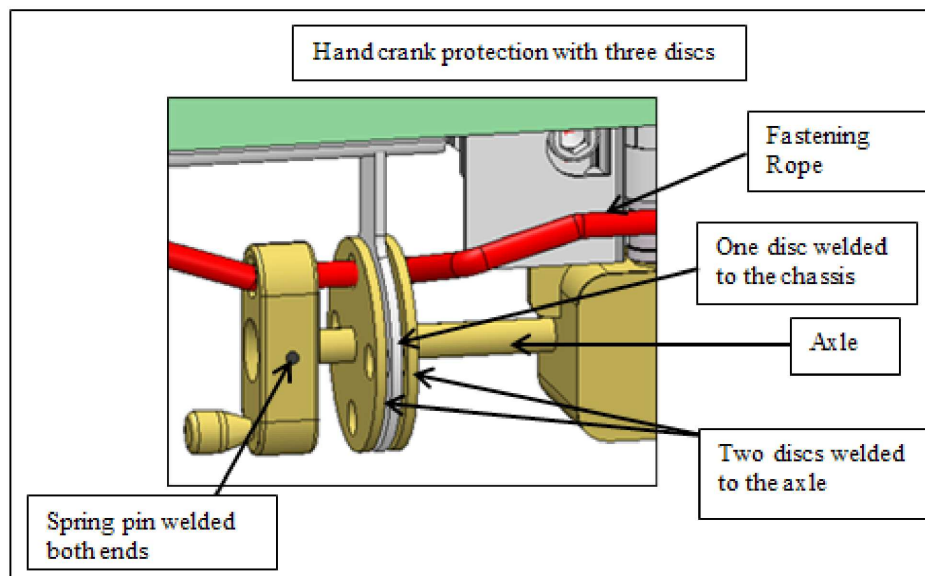
(a) Ratchet securing**(b) Gearbox securing**

Sketch No 9 continued:

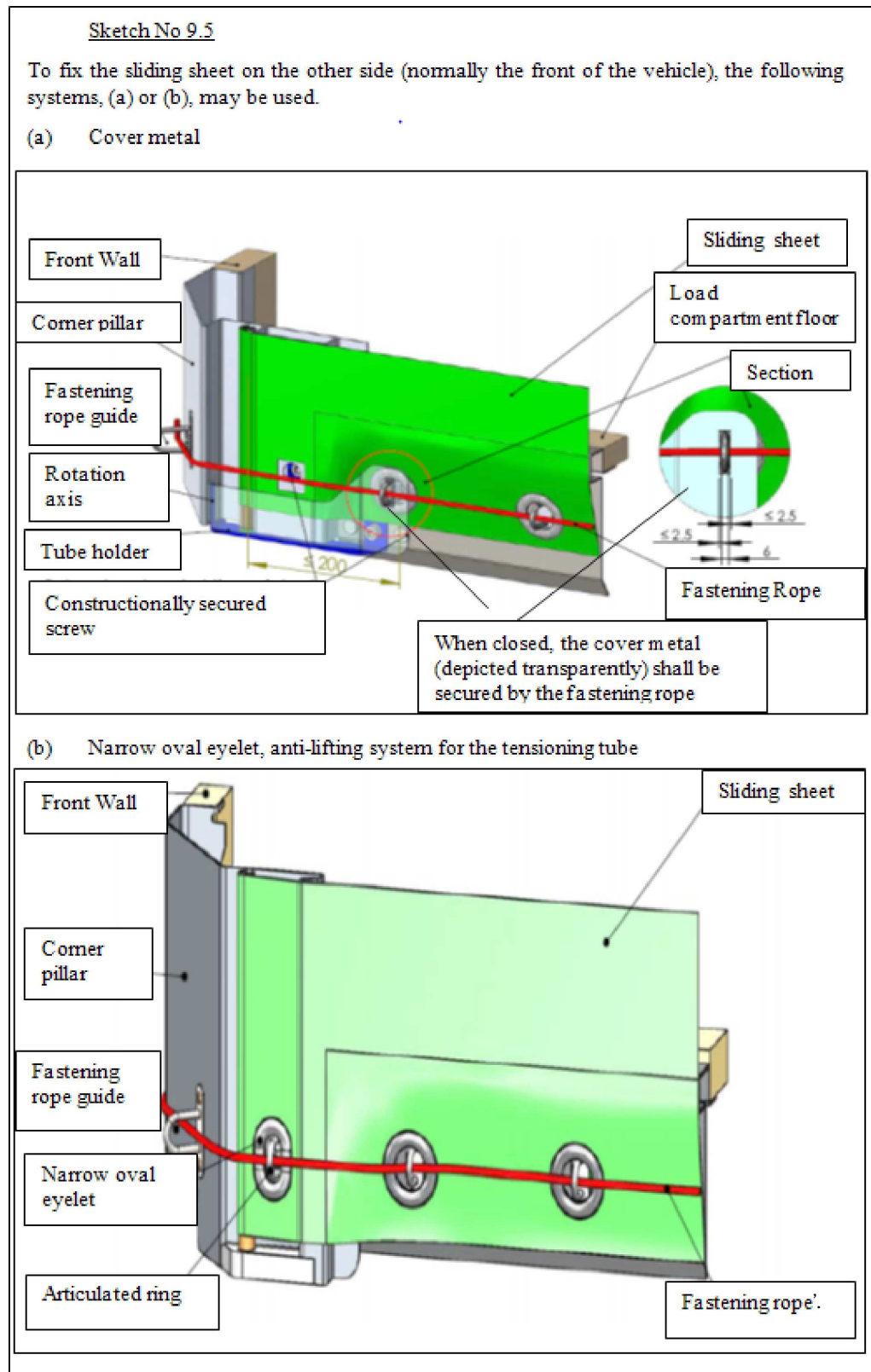

Annex 2, new Sketch No 10:

After new Sketch No 9 insert:

'Sketch No 10

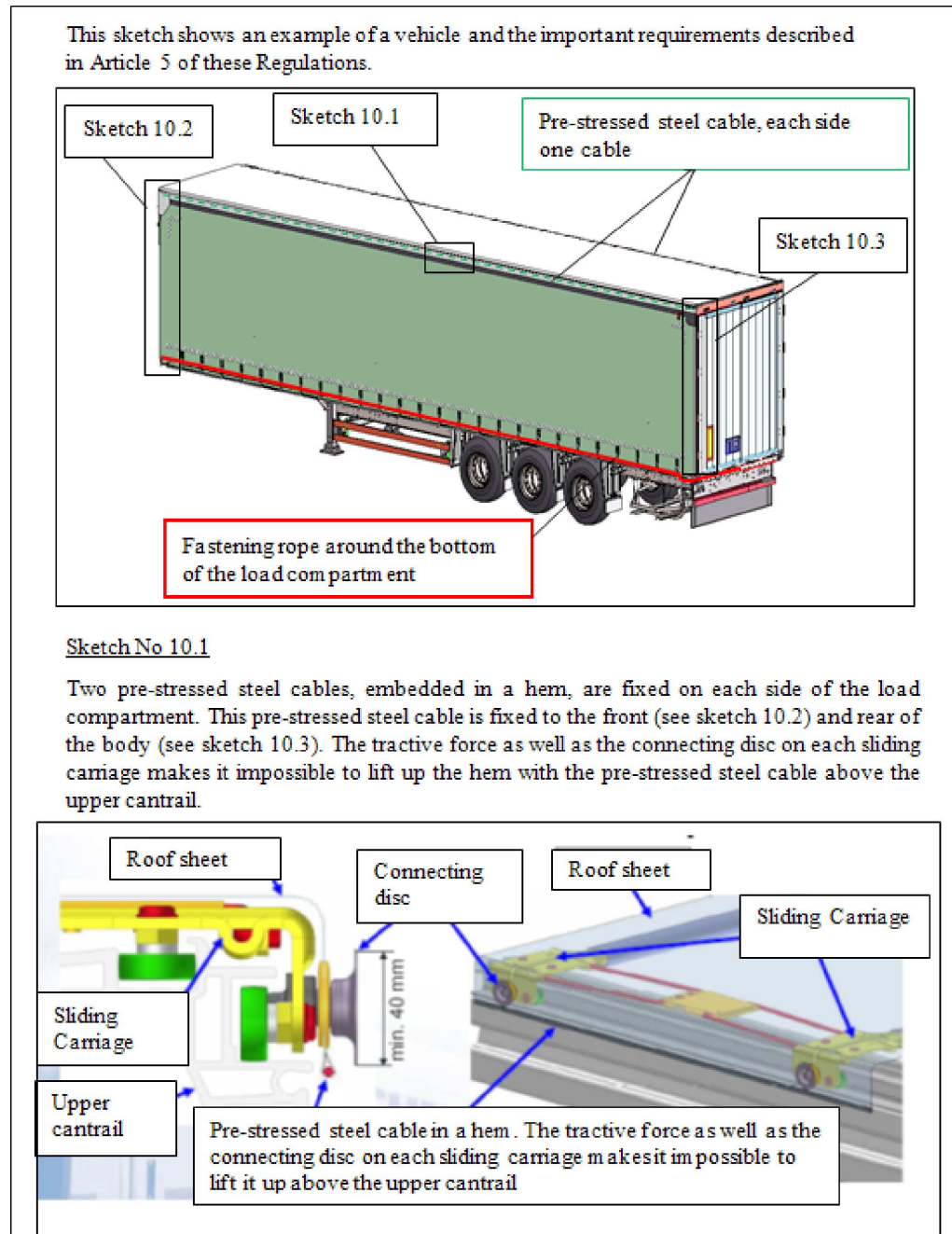
EXAMPLE OF A CONSTRUCTION OF A VEHICLE WITH A SHEETED SLIDING ROOF

Sketch No 10 continued:

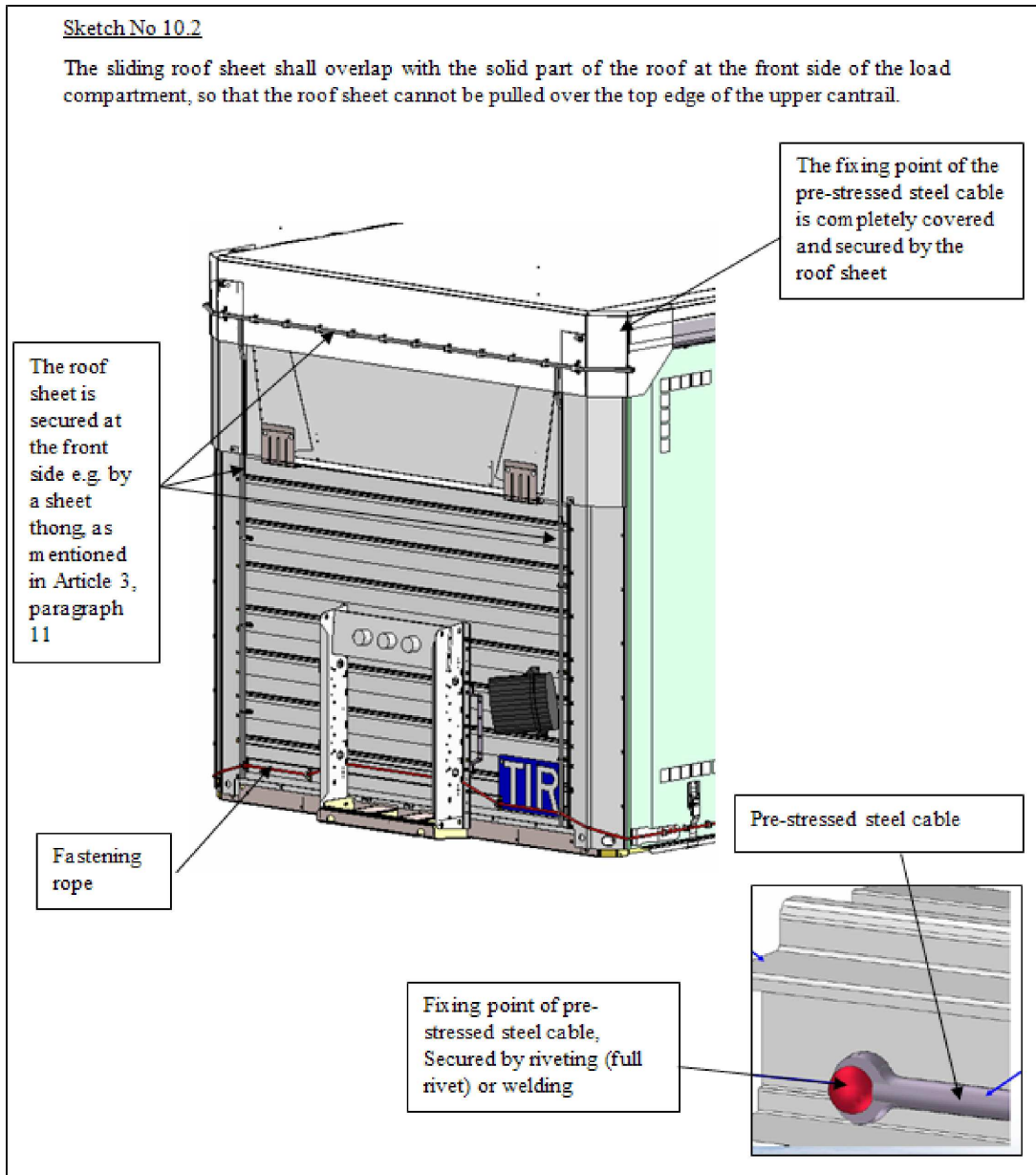

Sketch No 10 continued:

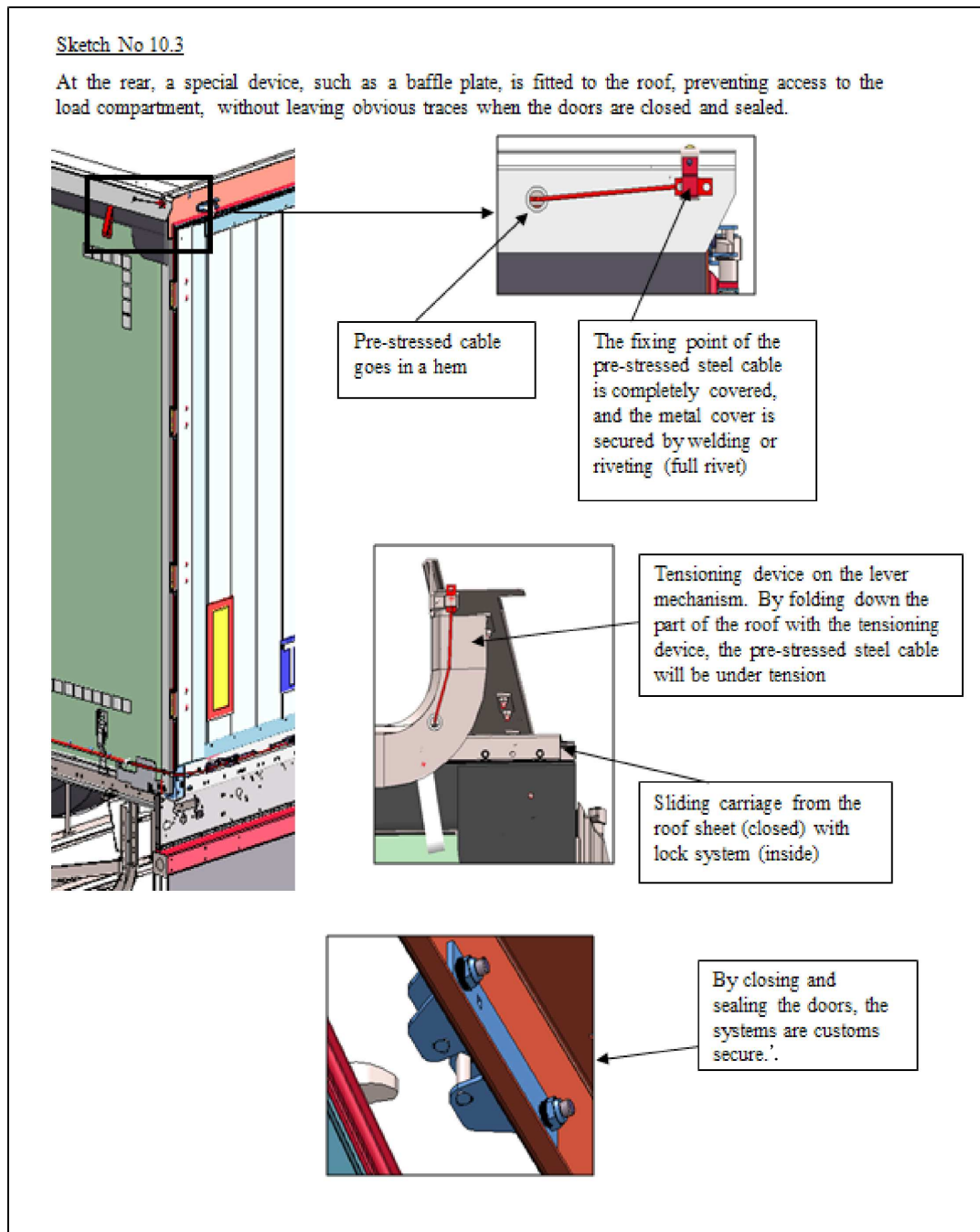

Annex 7, Part I, Article 5, paragraph 2(i):

For the existing text substitute:

- (i) The sliding sheets, floor, doors and all other constituent parts of the container shall be assembled either by means of devices which cannot be removed and replaced from the outside without leaving obvious traces, or by such methods as will produce a structure which cannot be modified without leaving obvious traces.'

Annex 7, Part I, Article 5, paragraph 2(iii):

For the existing text substitute:

- (iii) The sliding sheet guidance, sliding sheet tension devices and other movable parts shall be assembled in such a way that when closed, and Customs sealed, doors and other movable parts cannot be opened or closed from the outside without leaving obvious traces. The sliding sheet guidance, sliding sheet tension devices and other movable parts shall be assembled in such a way that it is impossible to gain access to the container without leaving obvious traces once the closing devices has been secured. An example of such a system of construction is given in sketch No 9 appended to these Regulations.'

Annex 7, Part I, new Article 6:

After the modified Article 5 insert:

Article 6

Containers with a sheeted sliding roof

1. Where applicable, the provisions of Articles 1, 2, 3, 4 and 5 of these Regulations shall apply to containers with a sheeted sliding roof. In addition, these containers shall conform to the provisions of this Article.
2. The sheeted sliding roof shall fulfil the requirements set out in (i) to (iii) below.
 - (i) The sheeted sliding roof shall be assembled either by means of devices which cannot be removed and replaced from the outside without leaving obvious traces, or by such methods as will produce a structure which cannot be modified without leaving obvious traces.
 - (ii) The sliding roof sheet shall overlap with the solid part of the roof at the front side of the container, so that the roof sheet cannot be pulled over the top edge of the upper cantrail. In the length of the container, at both sides, in the hem of the roof sheet, a pre-stressed steel cable shall be inserted in such a way that it cannot be removed and re-inserted without leaving obvious traces. The roof sheet shall be secured to the sliding carriage in such a way that it cannot be removed and re-secured without leaving obvious traces.
 - (iii) The sliding roof guidance, the sliding roof tension devices and other movable parts shall be assembled in such a way that when closed, and Customs sealed, doors, roof and other movable parts cannot be opened or closed from the outside without leaving obvious traces. The sliding roof guidance, sliding roof tension devices and other movable parts shall be assembled in such a way that it is impossible to gain access to the container without leaving obvious traces once the closing devices have been secured.

An example of a possible system of construction is shown in sketch No 10, appended to these Regulations.'

Annex 7, Part I, Sketch No 9:

For the existing Sketch No 9 substitute:

‘Sketch No 9

EXAMPLE OF A CONSTRUCTION OF A CONTAINER WITH SLIDING SHEETS

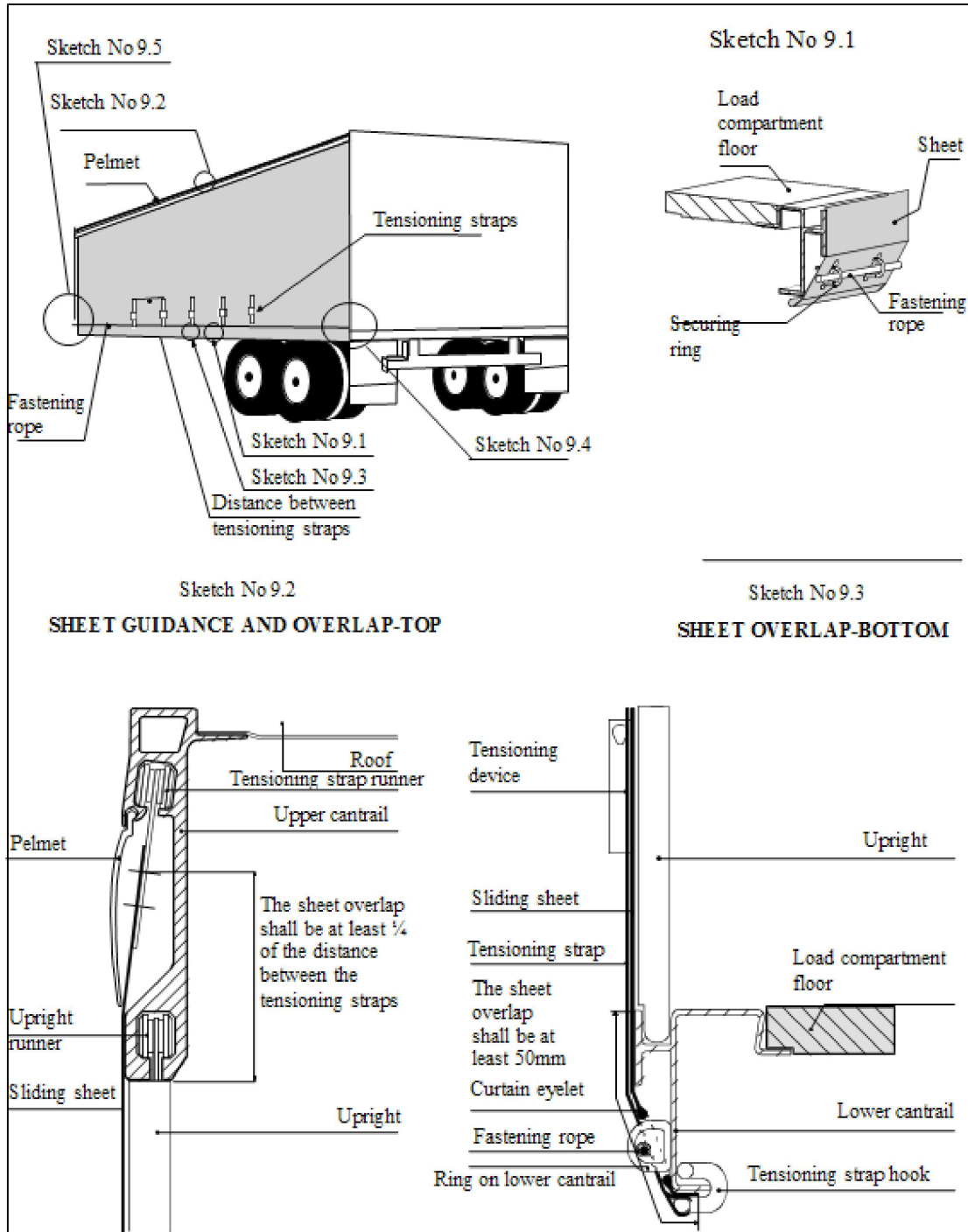

Sketch No 9 continued:

Sketch No 9.4

To tighten the sliding sheets in the horizontal direction, a ratchet gear is used (normally at the rear end of the container). This sketch shows two examples, (a) and (b), of how the ratchet or gearbox may be secured.

(a) Ratchet securing

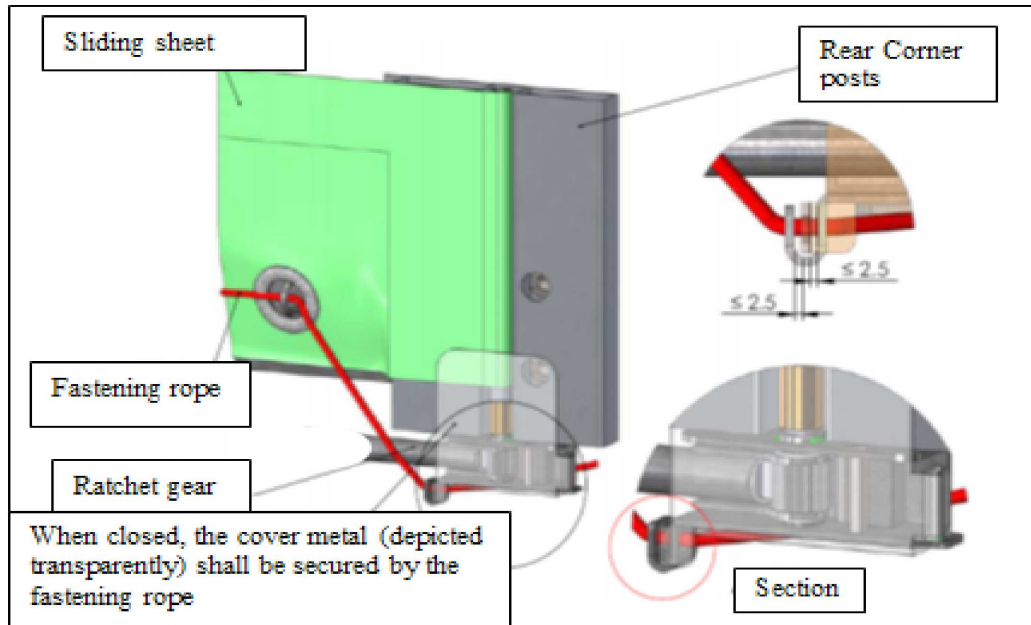

(b) Gearbox securing

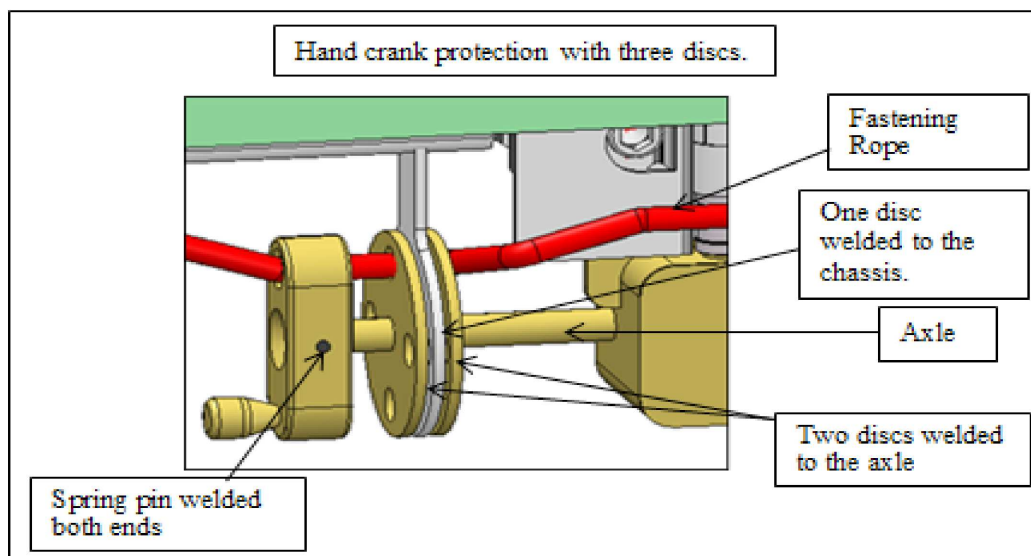

Sketch No 9 continued:

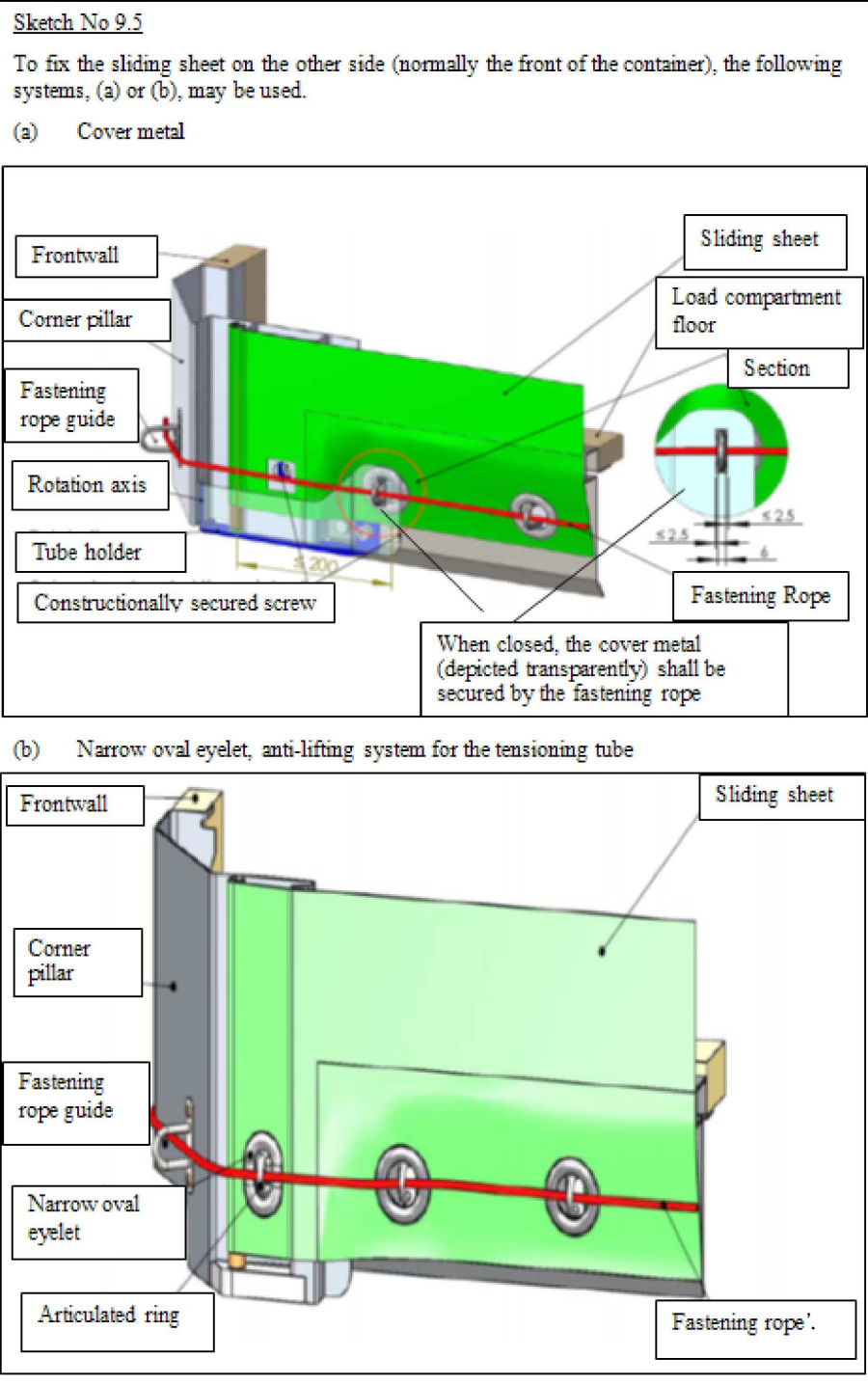

Annex 7, Part I, new Sketch No 10:

After new Sketch No 9 insert:

‘Sketch No 10

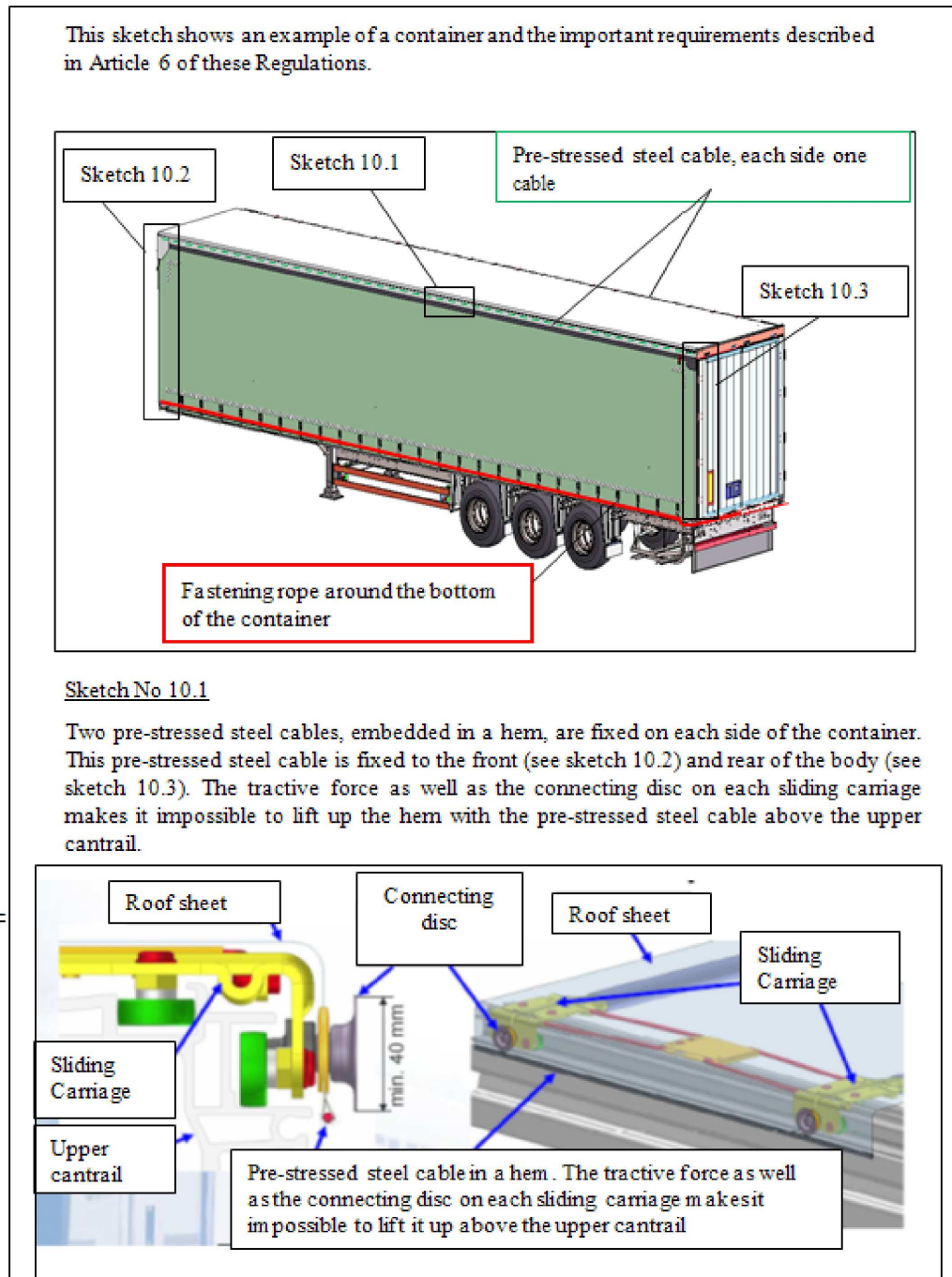
EXAMPLE OF A CONSTRUCTION OF A CONTAINER WITH A SHEETED SLIDING ROOF

Sketch No 10 continued:

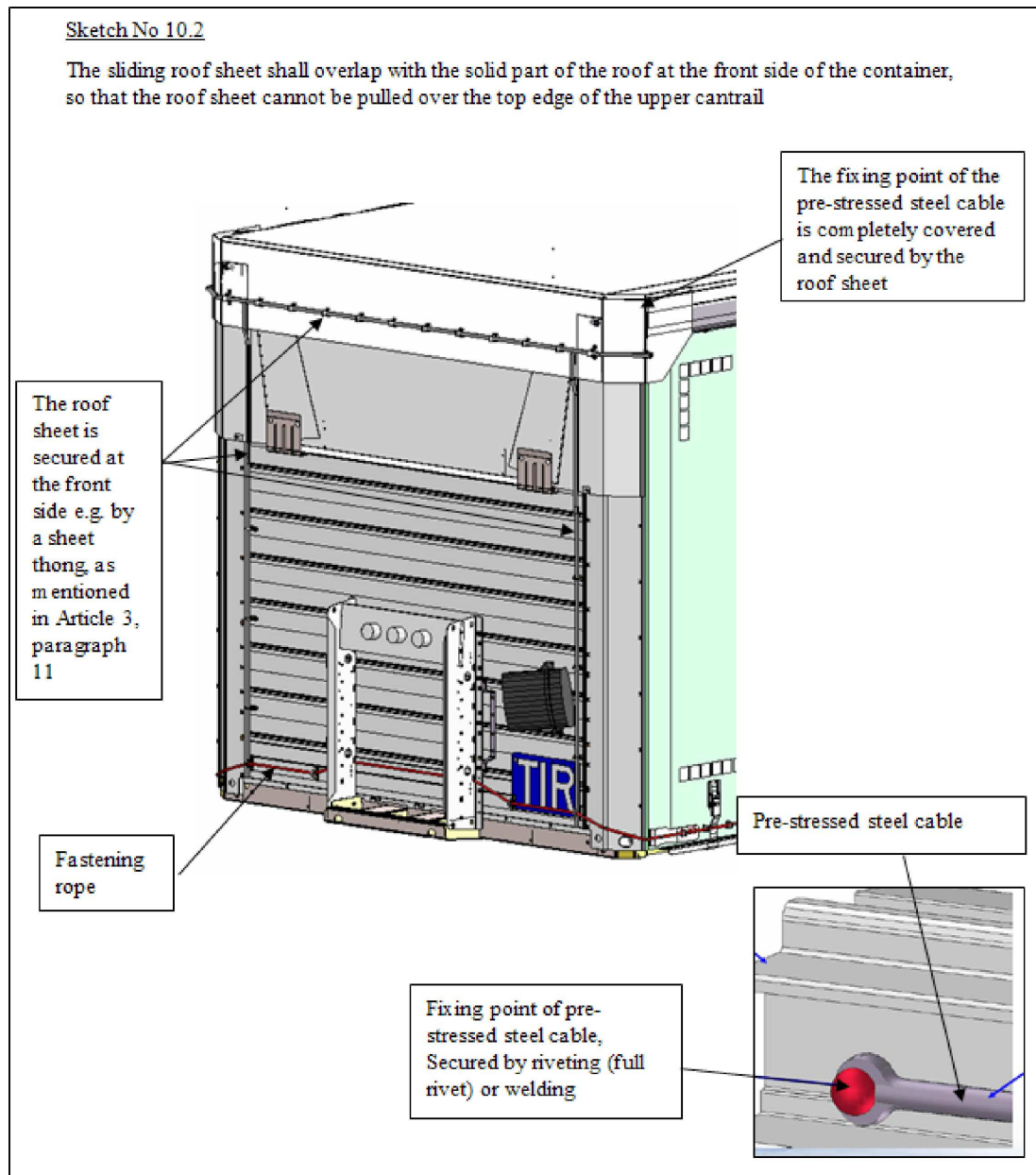

Sketch No 10 continued:

