

I congratulate the authors on a nicely written, interesting article on the assimilation of GNSS ZTDs and ZTD gradients into WRF using a fast observation operator, avoiding time consuming ray tracing. It has high value for the GNSS meteorological community. Being a first test one can always ask for more details and work, but I advocate publication with just minor adjustments in order to make it quickly available for others to use. It will be interesting to see in the future whether higher resolution NWP shows improved impact, and whether the benefit is still clear in NWP using more types of standard meteorological observations.

We thank the reviewer for taking the time to review the manuscript and for the kind words. Thank you very much for understanding the scientific motive behind our research. We want to share the GNSS gradient operator with the GNSS meteorological community so that we can optimize the use of gradients and figure out ways to use this abundant observation type in the operational forecast centers worldwide. We hope the readers can test the operator and make any improvements to the existing version.

Detailed comments:

Don't use dots as a sign for multiplication, like in equation 3. When you have defined ϕ as a function, it is clear that $\phi \Delta z$ means multiplication.

Thanks for the comment. This has now been corrected.

You use a limited set of standard meteorological observations in your DA. SYNOP will be available at all 4 assimilation times, but radiosondings are more rare at 06 and 18 UTC, than 00 and 12 UTC. Please specify how large the difference is in your area.

We agree with the reviewer that radiosondes are rare at 06 and 18 UTC compared to 00 and 12 UTC. To specify the difference in our domain, we have included a table below that indicates the average number and type of observations assimilated based on the respective timesteps for the two months. We have now incorporated the details in the revised manuscript. We would also like to point out that we had Tropospheric Airborne Meteorological Data Reporting (TAMDAR) observations along with the surface stations and radiosondes. We did not mention this in the manuscript by mistake. We take this opportunity to correct it.

Assimilation Timestep	SYNOP	Radiosonde	TAMDAR	GNSS	Total
00 UTC	1285	31	80	100	1496
06 UTC	1327	20	2196	102	3645
12 UTC	1328	60	2275	103	3766
18 UTC	1318	12	1752	103	3185

In figure 2, what does the shorter and shorter vertical green, blue and red lines indicate? Specify explicitly whether the 3 simulations run independently, ie. the ZTD and ZTD+gradients are assimilated in first guesses based on ZTD only and ZTD+gradients, not into the control first guess.

Thank you for pointing out the ambiguity in the figure. We agree that the colored arrows in the figure can be misleading and may confuse the readers. The ZTD and ZTD + gradients are two different experiments independent from the Control experiment. They do not use control first guess. This is now clarified and explained in the revised manuscript. Also with reference to comments from the second reviewer we have added an additional experiment with only gradient assimilation (GRA). The new figure is attached below.

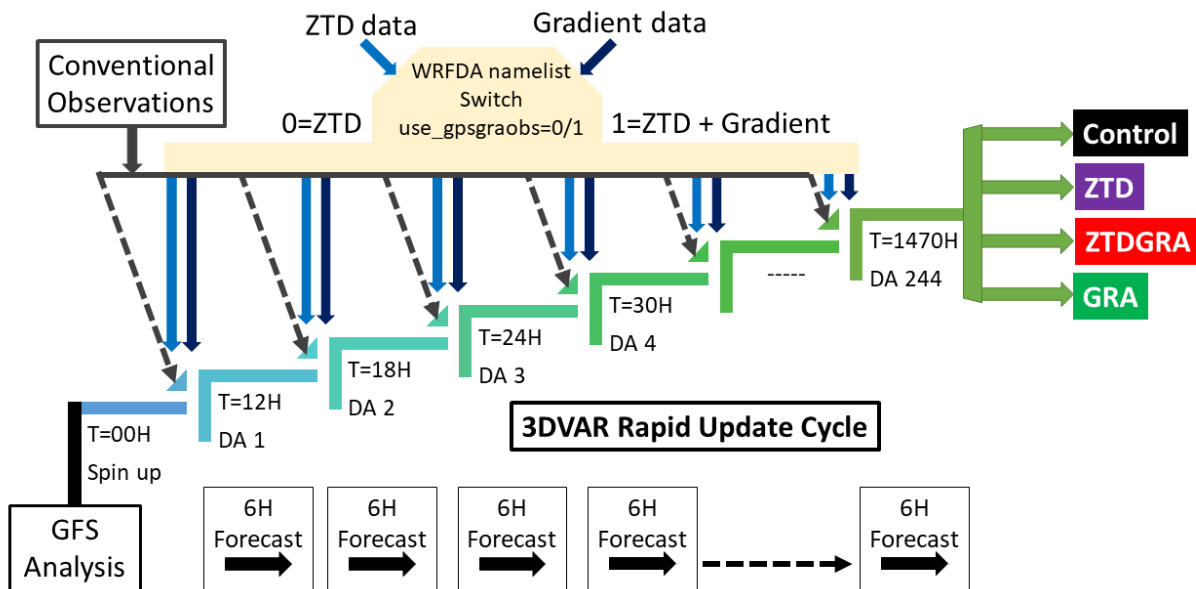

Figure 1. Schematic of the 3DVAR rapid update cycle initialized from the GFS analysis. A spin-up of 12 hours was performed until 00 UTC on June 01, 2021. Four experiments with different setups are performed: Control run (black) assimilating conventional data, ZTD run (purple) assimilating ZTDs on top of the control run, ZTDGRA run (red) assimilating ZTD and gradients on top of the control run, and GRA run (green) assimilating gradients on top of the control run. The WRFDA namelist switch use_gpsgraobs has 0 for ZTD assimilation and 1 for ZTD and gradient assimilation.

In figure 4, what is the location of the "lobes" where you obtain the profiles (is it for example a certain distance from the location of the GNSS sites?)

We thank the author for the comment. We have now explained how we obtain the profiles in the revised manuscript.

The location of the lobes are calculated through the following steps:

1. Average the analysis over the vertical levels between 2 km and 4 km, where the gradient observations have the maximum influence.

2. Determine the latitude and longitude of the point in the domain where the absolute value of the water vapor mixing ratio is maximum.
3. Through step 2, we get two maximum value points on both sides of the gradient observation location. The profile is derived from these two locations; hence, we get the lobes.

What is shown in figure 18? Is it the average rmse of the mixing ratio up through the radiosonde profile? That might be dominated by mixing ratios at certain heights. Or is it rmse at a certain level?

Thank you for the comment. We have now incorporated the explanation of this comment in detail in the manuscript for clarity.

Figure 18 shows the average RMSE of the mixing ratio up through the radiosonde profile. Since radiosonde profiles are usually available at irregular heights, we interpolated the model profiles to that of the radiosondes. Hence, the model profiles of the 12-hour forecast from the analyses were compared with the radiosonde profiles at that time instant to calculate the RMSE. We compared the forecasts valid at 12 UTC (forecasted from analyses at 00 UTC) with the radiosondes at 12 UTC, since there were more radiosondes during that time, to get the statistics. There were a minimum of 38 radiosondes available for comparison. The new updated figure (Figure 2) with the radiosonde RMSE forecast comparison is shown below. The new run GRA is also included in the updated figure.

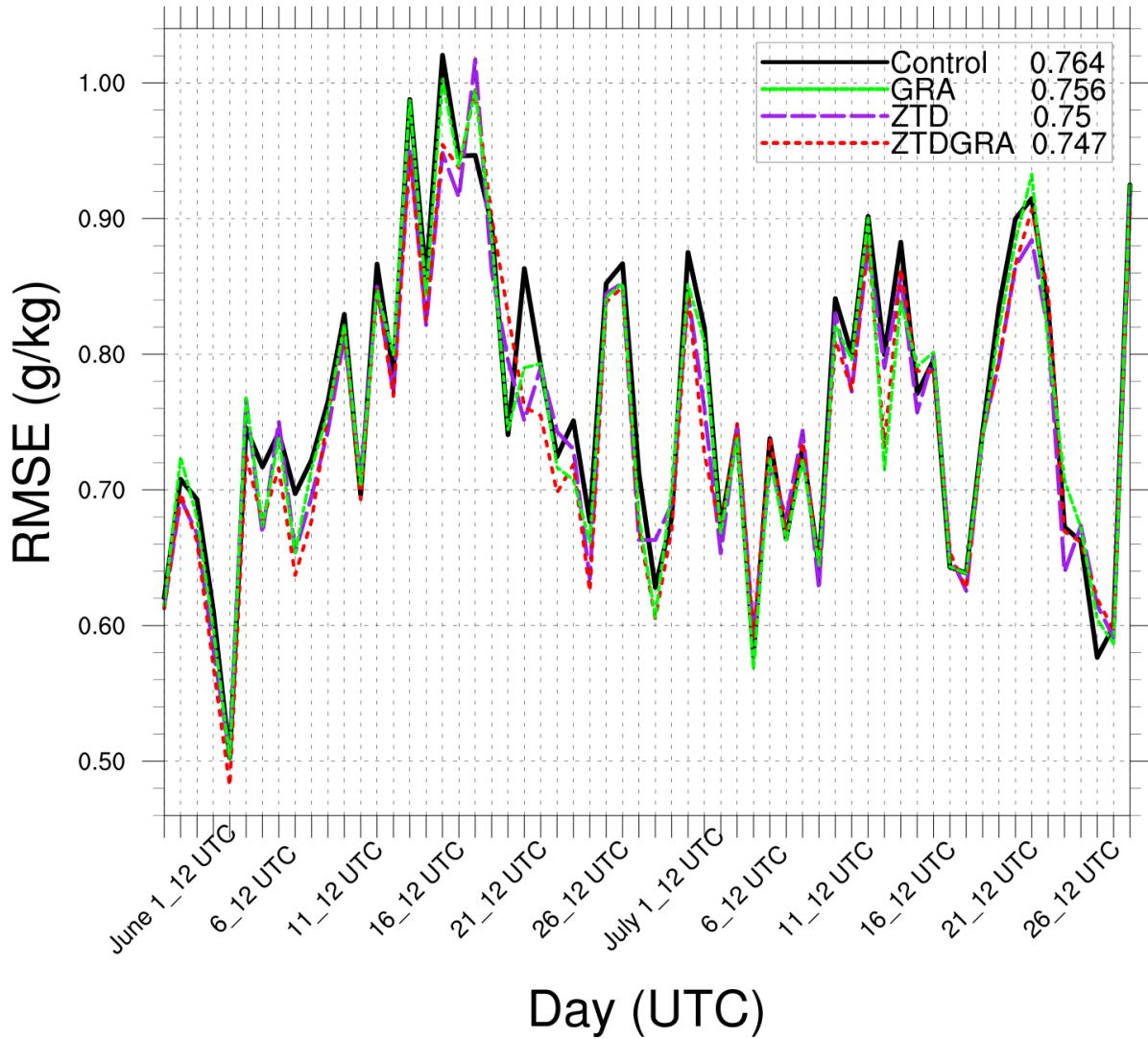

Figure 2. Water vapor mixing ratio comparison of the 12-hour forecasts from the analyses to the radiosonde profiles (around 38 radiosondes per epoch). The mean RMSE (g/kg) of the respective runs for the two months are specified in the legend.