

*Lib. Information*

AAEC/TM562

AAEC/TM562



**AUSTRALIAN ATOMIC ENERGY COMMISSION  
RESEARCH ESTABLISHMENT  
LUCAS HEIGHTS**

**HEAVY WATER PRODUCTION - A REVIEW OF PROCESSES**

by

**D.M. LEVINS**

**September 1970**

ISBN 0 642 99376 9

AUSTRALIAN ATOMIC ENERGY COMMISSION

RESEARCH ESTABLISHMENT

LUCAS HEIGHTS

HEAVY WATER PRODUCTION - A REVIEW OF PROCESSES

by

D. M. LEVINS

ABSTRACT

Methods of heavy water production are examined in detail. Processes based on chemical exchange have the greatest potential for further development but distillation, electrolytic and chromatographic methods are also discussed.

In the immediate future most of the world output of heavy water will be produced by hydrogen sulphide/water exchange (the GS process) but there is limited scope for further reduction in GS production costs. Recent advances in process development make the ammonia/hydrogen route an attractive alternative since the enrichment obtainable in each stage is greater while the energy consumption is less. A variation of the ammonia/hydrogen scheme involving the use of amines as additives to, or substitutes for ammonia also appears promising.

The greatest obstacle to the development of either the ammonia/hydrogen or amine/hydrogen schemes on a large scale is the limitation on the supply of hydrogen. Ammonia synthesis gas is currently the most plentiful supply available

continued...

ABSTRACT (continued)

but 1500 tonnes/day of ammonia capacity is needed for each 100 tonnes of heavy water produced annually. Unlimited production could be achieved using an equilibration stage in which hydrogen depleted in deuterium is exchanged with water at high temperature. The economics of this scheme depend on the development of a satisfactory catalyst for water/hydrogen equilibration.

Distillation of water, methane and hydrogen have been proposed as economic routes to heavy water production but design studies and experimental data would need to be clarified if optimistic forecasts are to be substantiated.

Processes based on chromatography or selective adsorption have received scant attention in the past. Many problems would need to be overcome before such processes could be adapted to large scale production of heavy water, but in view of recent advances in plant scale chromatography, they should be re-examined.

National Library of Australia card number and ISBN 0 642 99376 9

CONTENTS

|  | <u>Page</u> |
|--|-------------|
| 1. INTRODUCTION  | 1           |
| 2. SOURCES OF DEUTERIUM  | 1           |
| 3. WORLD PRODUCTION AND DEMAND FOR HEAVY WATER                         | 2           |
| 4. HEAVY WATER PRICES  | 2           |
| 5. SEPARATION PROCESSES  | 3           |
| 6. CHEMICAL EXCHANGE   | 4           |
| 6.1 Hydrogen Sulphide - Water Exchange (GS Process)                    | 5           |
| 6.1.1 General process considerations                                   | 5           |
| 6.1.2 Production facilities and economics                              | 7           |
| 6.2 Ammonia-Hydrogen Exchange  | 9           |
| 6.2.1 General process considerations                                   | 9           |
| 6.2.2 Production facilities and economics                              | 12          |
| 6.2.3 Amine-hydrogen exchange  | 14          |
| 6.3 Hydrogen-Water Exchange  | 14          |
| 6.3.1 Gas phase catalysis  | 15          |
| 6.3.2 Liquid phase catalysis   | 15          |
| 6.3.3 General process considerations                                   | 17          |
| 6.3.4 H <sub>2</sub> /H <sub>2</sub> O exchange for feed equilibration | 18          |
| 6.4 Other Chemical Exchange Reactions                                  | 19          |
| 6.4.1 Phosphine/water exchange   | 19          |
| 6.4.2 Halogen acids/water exchange                                     | 19          |
| 6.4.3 Alkanes/hydrogen exchange  | 20          |
| 6.5 Comparison of Chemical Exchange Processes                          | 21          |
| 7. DISTILLATION  | 21          |
| 7.1 Hydrogen Distillation  | 21          |
| 7.2 Water Distillation   | 23          |
| 7.3 Ammonia Distillation   | 24          |
| 7.4 Methane Distillation   | 25          |
| 8. ELECTROLYTIC SEPARATIONS  | 25          |
| 8.1 Electrolysis of Water  | 25          |
| 8.2 Electrolysis of Ammonia  | 26          |
| 9. CHROMATOGRAPHIC SEPARATIONS   | 27          |
| 10. CONCLUDING COMMENTS  | 29          |
| 11. ACKNOWLEDGEMENT  | 30          |
| 12. REFERENCES   | 30          |

## CONTENTS (continued)

|           |  |
|-----------|--|
| Table 1   | Feed requirements to produce 100 tonnes heavy water/year   |
| Table 2   | Heavy water production plants  |
| Table 3   | Overall separation factors for dual temperature exchange   |
| Table 4   | Temperatures of hydrate formation and liquefaction for hydrogen sulphide   |
| Table 5   | Costs of heavy water production (GS process)   |
| Table 6   | Murphree plate efficiencies for $\text{NH}_3/\text{H}_2$ exchange  |
| Table 7   | Comparison of costs for GS and $\text{NH}_3/\text{H}_2$ plants   |
| Table 8   | Breakdown of costs for 360 tonnes/year heavy water plant: - water-based $\text{NH}_3/\text{H}_2$ dual temperature exchange |
| Table 9   | Properties of aliphatic amines   |
| Table 10  | Rate of hydrogen - water exchange with various catalysts   |
| Table 11  | Properties of methane, ethane, ammonia and water   |
| Table 12  | Comparison of chemical exchange processes for heavy water production   |
| Table 13  | Approximate separation factors for distillation  |
| Table 14  | Comparison of Sulzer packed column with sieve-plate column at Savannah River   |
| Table 15  | Economics of ammonia distillation  |
| Table 16  | Vapour pressures of methanes above one atmosphere  |
| Figure 1  | Chemical exchange processes  |
| Figure 2  | Effect of temperature on separation factor for chemical exchange reactions   |
| Figure 3  | Savannah River GS unit   |
| Figure 4  | Ejector arrangement used at Mazingarbe plant to improve contact efficiency   |
| Figure 5  | French plant at Mazingarbe   |
| Figure 6  | German design for dual temperature $\text{NH}_3/\text{H}_2$ exchange   |
| Figure 7  | Canadian flowsheet for dual temperature $\text{NH}_3/\text{H}_2$ exchange-synthesis gas feed                               |
| Figure 8  | Canadian flowsheet for dual temperature $\text{NH}_3/\text{H}_2$ exchange with water-based feed equilibration              |
| Figure 9  | Schematic diagram of Trail plant   |
| Figure 10 | Separation by gas chromatography   |

## 1. INTRODUCTION

In power reactors moderated by heavy water the low neutron absorption cross section of heavy water enables natural or low enrichment uranium dioxide to be used effectively with good fuel utilisation and low fuel cost. However these advantages are partially offset by the high cost of heavy water which contributes significantly to the capital cost of the reactors.

Inventory requirements for heavy water reactors vary considerably with reactor design and fuel characteristics. For reactors utilising natural uranium with heavy water as moderator and coolant as typified by CANDU-PHW reactors, the inventory is approximately one tonne of heavy water/MWe. Improvements in design should reduce this to 0.55 tonnes/MWe after 1976 (Cochran 1966). An inventory of one tonne of heavy water/MWe represents about 16 per cent of the total reactor capital investment and from 10-15 per cent of the total cost of generation (Bancroft 1968). The British SGHWR which uses slightly enriched uranium dioxide fuel, heavy water as moderator, and boiling light water as coolant, requires about 0.26 tonnes of heavy water/MWe (Wright - A.A.E.C. private communication).

A significant reduction in price will strengthen the market position of heavy water moderated reactors and considerable research and development is under way to refine existing processes and to explore new production routes.

This survey critically examines the processes and indicates areas of research and development likely to lead to a reduction in heavy water costs.

## 2. SOURCES OF DEUTERIUM

The deuterium concentration in natural hydrogen sources expressed as the ratio of deuterium to total hydrogen atoms, generally varies within the range 120-160 ppm. Any hydrogenous compound is a potential source of deuterium and therefore heavy water, but only water, hydrogen, ammonia and methane are available in sufficient quantities to be considered for large scale production. Of these materials, only water can be regarded as a limitless source. Typical requirements of water, ammonia synthesis gas, and hydrogen as feed for a 100 tonne/year heavy water plant are shown in Table 1.

The concentration of deuterium in deep ocean water varies little from an average value of 158 ppm, but, because of selective evaporation, this concentration is above that of surface waters. Variations in deuterium concentration over a continental land mass are also observed. As moist air moves inland from the sea, falls of rain or snow are enriched in deuterium by fractional condensation and the residual water vapour is depleted. Successive falls have a lower deuterium concentration. The deuterium concentration in rivers is increased by fractional evaporation as they flow towards the sea. Both these effects

result in a gradient across a land mass with coastal rivers richest in deuterium (Bancroft and Brown 1967). A Canadian survey found that the typical deuterium content of inland rivers was 130-140 ppm, while that of coastal rivers was 140-150 ppm (Brown et al. 1967). Since the cost of heavy water production is inversely proportional to the deuterium concentration of the feed, each ppm difference in feed concentration is equivalent to approximately \$0.26/kg in the final heavy water cost (Bancroft and Brown 1967). The location of a heavy water plant is therefore important in determining the overall cost of production.

Hydrogen is available from coke-oven gas, water gas, fuel oil, catalytic reforming gas, natural gas and from the electrolysis of water or brine solutions. At present the largest hydrogen streams are available as synthesis gas for ammonia production. Benedict (1955) reported that hydrogen in synthesis gas contained from 108-127 ppm deuterium. This abnormally low level was attributed to concentration of deuterium in the unconverted steam from the water-gas shift reaction. He estimated that if this steam were recycled, the deuterium concentration of the hydrogen could be increased to around 136 ppm.

Methane is available in large quantities in natural gas and is important because of its possible use as a source of hydrogen. Few measurements of the deuterium concentration in methane have been reported but it appears that the concentration is significantly below that of natural waters. Bancroft (1968) reported 117-133 ppm concentrations in Canadian natural gases.

### 3. WORLD PRODUCTION AND DEMAND FOR HEAVY WATER

By the end of 1972, world production of heavy water should exceed 1,800 tonnes/year. Table 2 shows the status and location of major plants.

A Canadian survey (Cochran 1966) estimated that world demand for heavy water would average 1,960 tonnes/year over the period 1971-1975, 3,900 tonnes/year for 1976-1980 and 6,200 tonnes/year for 1981-1985. Proposed plants can therefore barely meet the most immediate needs and a serious shortage will occur in 1971-2 until the new large Canadian plants are operational.

### 4. HEAVY WATER PRICES

The price of heavy water produced by the Savannah River plant is \$US 66.00/kg (USAEC 1969). However, the second generation G2 plants in Canada will sell heavy water under contract to Atomic Energy of Canada Ltd. for an average price of \$CAN 40.00/kg (Bancroft 1968). Further, but less substantial, cost reduction may be expected from the \$CAN 115 million heavy water complex at Bruce Point.

## 5. SEPARATION PROCESSES

Separation processes can be classified broadly according to reversibility. In a reversible or equilibrium process such as distillation or fractional adsorption, components of a mixture spontaneously approach equilibrium without requiring external work. Irreversible processes such as mass diffusion or electrolysis are characterised by their need for a continuous supply of work and in general they use energy inefficiently.

The best single measure of the separating power of any process for isotope enrichment is the separation factor,  $\alpha$ . It is defined in terms of the concentration of each component in the light and heavy streams leaving a separation stage,

$$\alpha = \frac{y(1-x)}{x(1-y)}, \quad \dots(1)$$

where  $y$  and  $x$  refer to the atom fractions of the light component in respectively the light and heavy streams. For a given duty, the separation factor is a measure of the number of ideal stages required. The number required to achieve a given separation with minimum volume and energy consumption (Benedict and Pigford 1957; Pratt 1961) is

$$N_M = 2 \left[ \frac{\ln \frac{x_p(1-x_w)}{x_w(1-x_p)}}{\ln \alpha} \right] - 1, \quad \dots(2)$$

where  $x_p$  and  $x_w$  are the product and waste compositions respectively. Applying Equation 2 to the concentration of heavy water where the feed concentration  $x_F$  is likely to be 140 to 150  $\times 10^{-6}$  with a product stream at concentration  $x_p = 0.998$  and a waste stream rejected at  $x_w = 130 \times 10^{-6}$  gives  $N_M = 620$  stages for  $\alpha = 1.05$  but only 90 for  $\alpha = 1.40$ .

The total internal flow rate in an ideal cascade (Benedict and Pigford 1957) is

$$F = \frac{2(\sqrt{\alpha}+1)}{(\sqrt{\alpha}-1)\ln\alpha} \sum_i F_i (2x_i-1) \ln \frac{x_i}{1-x_i}, \quad \dots(3)$$

where  $F_i$  is the molar flow rate of an external stream (positive when product, negative when feed) of composition  $x_i$ . Since the total internal flow rate is related to both plant size and power demand, it can be used as a guide in evaluating the effect of the separation factor and the product and feed compositions on total costs. For example, other conditions being equal, the total internal flow for  $\alpha = 1.40$  is only 2 per cent of the flow rate when  $\alpha = 1.05$ .

Although Equations 2 and 3 are useful guides to the number of stages required and the flow rate through the cascade, there is no strict relation

between these factors and product cost. In general, the processes most likely to be successful are those which combine an adequate separation factor with efficient energy recovery. Since reversible processes such as chemical exchange and distillation give acceptable separation factors for hydrogen isotopes they have generally been found to offer the best prospects (Ryan 1967).

#### 6. CHEMICAL EXCHANGE

Chemical exchange methods of producing heavy water rely on a shift in equilibrium in a reaction of the type



where H and D represent respectively the isotopes of mass number one (protium) and two (deuterium). The equilibrium constant for this reaction is

$$K = \frac{[YD][XH]}{[XD][YH]} \quad \dots(5)$$

where concentrations, [YD], [XH] etc., can be expressed in either the gas or liquid phase. The separation factor  $\alpha$  is equal to K provided the two reactants have an equal number of interchangeable atoms and are immiscible. For gas-liquid chemical exchange in the region of low deuterium concentrations, Pratt (1961) gives the separation factor as

$$\alpha = \alpha^* \frac{(S + K_v)(R + H)}{(1 + K_v)(1 + RS)} \quad \dots(6)$$

where R is the molar ratio of interchangeable hydrogen atoms in XH and YH.

$\alpha^*$  is the relative volatility of XH, with respect to XD, or YH with respect to YD (assumed to be equal),

H the humidity, is the number of moles of liquid per mole of gas in the gas phase,

S the solubility, is the number of moles of gas per mole of liquid in the liquid phase,

$K_v$  is the equilibrium constant in the vapour phase.

Large overall separation factors can be achieved in two ways; dual temperature operation and monothermal operation (see Figure 1).

##### (i) Dual temperature operation

This method takes advantage of the change in the equilibrium constant with temperature. The effect of temperature on the separation factor for a number of

hydrogen-deuterium exchange reactions is shown in Figure 2.

A typical dual temperature unit consists of two countercurrent contacting towers operating in series. A liquid feed stream enters the 'cold' tower and is progressively enriched in deuterium by exchange with enriched gas. Some of this stream is withdrawn as product from the base of the cold tower; the remainder is fed to the 'hot' tower whose purpose is to strip the feed stream of its deuterium and so provide an enriched gas reflux to the cold tower. In dual temperature exchange, the ratio of the separation factors in the cold and hot towers is a measure of the ease of separation (Benedict and Pigford 1957, Barr and Drews 1960). An overall separation factor is often defined (Ayres 1969) as

$$\alpha_{\text{overall}} = \frac{\alpha_{\text{cold}}}{\alpha_{\text{hot}}} \quad \dots(7)$$

The maximum recovery for a dual temperature system without a stripping section (Pratt 1961) is

$$\text{percent recovery} = \left(1 - \frac{\alpha_{\text{hot}}}{\alpha_{\text{cold}}}\right) \times 100 \quad \dots(8)$$

Overall separation factors for dual temperature exchange for a number of systems are listed in Table 3. In both Figure 2 and Table 3 effects due to gas solubility and liquid volatility, which tend to lower the effective separation factor (see Equation 6) have not been considered.

##### (ii) Monothermal operation

In this mode of operation, reflux is provided by converting the enriched liquid at the base of the exchange tower into the gas phase. This method can therefore only be used when one component can be chemically transformed into the other species. Monothermal operation of water-hydrogen and ammonia-hydrogen exchange processes, for example, is feasible because  $\text{NH}_3$  and  $\text{H}_2\text{O}$  can be converted into hydrogen by thermal or electrolytic decomposition. Monothermal operation has a lower tower volume requirement but this advantage is often offset by the costs of chemical conversion.

#### 6.1 Hydrogen Sulphide - Water Exchange (GS Process)

##### 6.1.1 General process considerations

The GS (Girdler-Sulphide or Girdler-Spevack) dual temperature process is the main method currently used for heavy water production. It combines an adequate separation factor with moderate energy requirements. The process utilises a shift in the equilibrium of the chemical reaction;



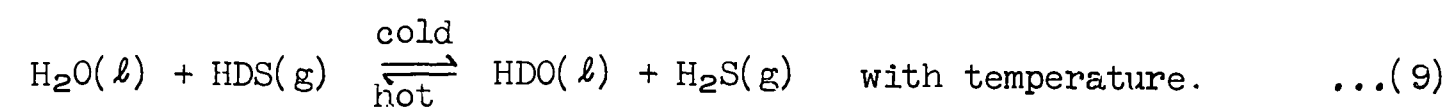

This reaction is ionic and rapid so plate efficiencies in the range 60-65 per cent can be achieved without a catalyst in conventional distillation equipment (Bebbington et al. 1959).

The basic arrangement, a pair of gas-liquid, countercurrent, contacting columns, is shown in Figure 1a. For the GS process, operating pressure is about 2,100 kN/m<sup>2</sup> (300 psia) and the temperatures are approximately 30°C in the cold tower and 130°C in the hot tower. The equilibrium constant for Equation 9 is 2.22 at 30°C and 1.76 at 130°C giving an overall separation factor of approximately 1.26 (Table 3). Deuterium is transferred from the hydrogen sulphide to the feed water in the cold tower. The direction of transfer is reversed in the hot tower, but, because of the differences in the equilibrium constant at different temperatures, the water leaving the hot tower is depleted in deuterium relative to the feed. The deuterium concentration is a maximum in the water stream at the base of the cold tower and in the gas stream at the top of the hot tower; parts of these streams are withdrawn and fed to another pair of GS columns for further enrichment. As water is freely available, it is not customary to recycle it from the base of the hot tower. The maximum deuterium recovery is limited to about 20 per cent (see Equation 8). Hydrogen sulphide circulates in a closed loop within the system, acting as a transport medium for deuterium. Enriched water and hydrogen sulphide are withdrawn at the base of the cold tower and passed to higher stages for further enrichment.

Despite its proven success the GS process has several limitations which have led to the study of new production routes:

(i) The overall separation that can be achieved in a dual temperature system increases as the temperature spread between the hot and cold towers is increased. Also, equipment size can be decreased if column pressure is increased. The properties of the H<sub>2</sub>S/H<sub>2</sub>O mixture restrict both the temperature spread and the operating pressure. Table 4 summarises the conditions for solid hydrate (H<sub>2</sub>S·6H<sub>2</sub>O) formation and H<sub>2</sub>S liquefaction as a function of pressure. The maximum operating pressure is limited to about 2,100 kN/m<sup>2</sup> (300 psia) by the liquefaction of H<sub>2</sub>S and the cold tower temperature cannot be decreased below 30°C because of hydrate formation. The hot tower temperature cannot be increased above 140°C owing to vaporisation of water in the hot tower.

(ii) Examination of Figure 2 shows that, of the systems represented on that graph, the equilibrium constant for the H<sub>2</sub>S/H<sub>2</sub>O system has one of the lowest temperature coefficients. The small effect of temperature, coupled with the restrictions in the hot and cold tower temperatures noted above, results in a

relatively small overall separation factor (see Table 3). In this respect, the H<sub>2</sub>/H<sub>2</sub>O and NH<sub>3</sub>/H<sub>2</sub> systems are markedly superior.

(iii) Carbon steel is readily attacked by hydrogen sulphide in water, but the rate of attack decreases to acceptable limits as an iron sulphide protective coating builds up on the surface (Thayer and De Long 1962). However, if this coating is continually removed by impingement of liquid, the corrosion rate remains high. Pilot plant data (Bebbington et al. 1959) showed that for equipment subject to high flow velocities such as control valves, tray towers and heat exchangers, satisfactory performance could be obtained using stainless steel, preferably of type 316.

Stress corrosion cracking and blistering due to diffusion of hydrogen into the metal introduces further problems. All vessels containing hydrogen sulphide must be stress relieved after fabrication and bolts must be heat treated to reduce their hardness below 27 on the Rockwell C scale (Bebbington et al. 1959).

The measures outlined above are designed to control rather than to stop corrosion. As a result, maintenance and replacement costs in the GS process can be anticipated to be appreciably higher than those applicable to a less corrosive environment.

(iv) A 400 tonne/yr GS plant requires an inventory of about 700 tonnes of H<sub>2</sub>S (Bebbington et al. 1959). This gas constitutes a significant safety hazard since the toxicity of H<sub>2</sub>S is about the same as hydrogen cyanide. All equipment containing H<sub>2</sub>S must be located in the open, gas monitors and alarms must be strategically placed and operating personnel must work in pairs and carry gas masks. A system of isolating and dump valves is required.

#### 6.1.2 Production facilities and economics

Two GS plants were constructed in the United States in the early 1950's at Dana, Indiana, and Savannah River, South Carolina, with a combined capacity of about 850 tonnes/year (Bebbington et al. 1959). In 1957-1958, the projected demands for heavy water were not sufficient to justify operation of both plants and the Dana plant and part of the Savannah River plant were permanently shut down. Current production rate at Savannah River is about 160-180 tonnes/year (Bebbington and Thayer 1959; Barr 1966).

A flow diagram of a unit of the Savannah River plant is shown in Figure 3. The plant originally had 24 such units. The natural concentration of the feed-water is increased from 145-150 ppm heavy water to about 600-800 ppm in the first stage. In the second stage, it is increased to about 15 per cent. The Dana plant had five GS stages and more closely approximated an ideal continuously

tapered cascade but its operation was more complex.

Although the GS process can be used to concentrate water to 99.8% D<sub>2</sub>O, vacuum distillation and water electrolysis were chosen as finishing operations at both Dana and Savannah River because they were not subject to losses through leaks or process upsets. The cost of these finishing operations is only about 5 per cent of the total cost (Bebbington et al. 1959).

Control of the dual temperature columns poses unique problems. If both hot and cold columns are to be operated efficiently, the liquid to gas flow rates through the two towers must be fixed within narrow limits. For satisfactory operation, the molar ratio of gas to liquid flow rates in both columns should lie between the separation factors applicable to the hot and cold towers (Bebbington et al. 1959). Deviation from optimum conditions in either direction results in a decrease in production rate. A method was developed to control this ratio to within  $\frac{1}{2}$  per cent by measuring the ratio of deuterium concentrations at the mid-point of the two columns (Morris and Scotten 1962).

The total investment at Savannah River of \$US.164 million represented a cost of about \$320/(kg/year) (Bebbington et al. 1964). Power and steam requirements were 680 kWh and 5,600 kg of 6,200 kN/m<sup>2</sup> (900 psia) steam per kg of heavy water produced (Bebbington and Thayer 1959). Total operating cost was \$US.29.70 per kg of heavy water produced.

On examining the economics of heavy water production, Proctor and Thayer (1961, 1962a, 1962b) proposed modifications to the original GS process which they claimed would reduce heavy water costs to \$US.38/kg. Some of these modifications were:

- (a) Natural gas replaced coal as a source of energy and gas fired process heaters were incorporated directly into the GS process.
- (b) The heat recovery system was simplified and redesigned following the ideas of Spevack (1957, 1959).
- (c) The diameter of the towers in the first stage was increased to the maximum size consistent with shipping and fabricating costs.
- (d) A three-stage cascade, which represents a compromise between the Dana and Savannah River plants, was selected to give a 15 per cent D<sub>2</sub>O product.
- (e) Sieve plates were specified throughout the plant. It was estimated that this would result in a 40 per cent reduction in tray costs and a 15 per cent increase in tower throughput (see Proctor 1963; Garvin and Norton 1967, 1968).

- (f) Hydrogen sulphide make-up gas was generated within the GS unit by the addition of sodium hydrosulphide to the feedwater.

A breakdown of costs for the Proctor-Thayer design is compared with the corresponding costs for the Savannah River plant in Table 5.

Although the Savannah River plant is the only GS installation operating at this time, four new plants, three in Canada and one in India of about 1,600 tonnes/year total capacity, are under construction (see Table 2) (Nuclear Canada 1968, 1969b; Canadian Nuclear Technology 1966; Law 1968). Some of Proctor and Thayer's modifications have been incorporated into the new plants, but except for the Deuterium of Canada Ltd. plant at Glace Bay, Nova Scotia, all installations are of the conventional design established in the U.S.A.

The Glace Bay plant was designed to accept sea water as a deuterium feed source and it was proposed to produce 99.8% D<sub>2</sub>O by a five-stage GS cascade (Canadian Chemical Processing 1967). Process details have not been reported, but it appears that H<sub>2</sub>S is first equilibrated with sea water at elevated temperatures in a 'feed and effluent system' (Nuclear Canada 1969c). The enriched gas then becomes the feed to a train of hot and cold towers in which fresh water is circulated in a closed cycle. This system has the advantage that, since the optimum gas to liquid ratio is of the same order as the separation factor and is always greater than 1 (Bebbington et al. 1959), the production capacity of a plant operating with gas feed is correspondingly higher. The Glace Bay plant was originally due to start operations in 1967 but has been beset with problems. It has been estimated that a further \$CAN.30 million will be required to place the plant in an operating condition and it is unlikely to start up before 1972 (Nuclear Canada 1969c).

## 6.2 Ammonia-Hydrogen Exchange

### 6.2.1 General process considerations

The separation factor for the reaction

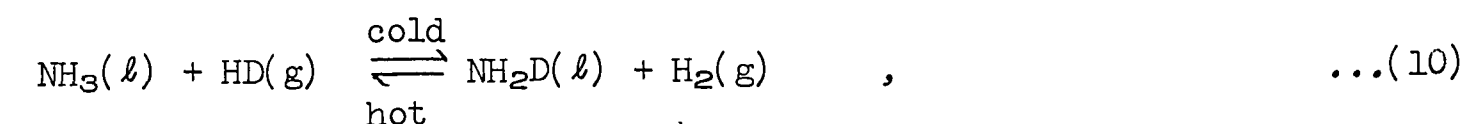

is much larger than for the GS process, while the temperature coefficient of the separation factor is also markedly higher (see Figure 2). For dual temperature operation with cold and hot tower temperatures of -40°C and 70°C, the overall separation is 2.03. This compares with the value of 1.26 for the conventional GS process. On this basis, the NH<sub>3</sub>/H<sub>2</sub> exchange reaction is a markedly superior route to deuterium enrichment. In addition, corrosion is not expected to represent a major problem as in the GS process (Le Chatelier 1968).



Exchange in the  $\text{NH}_2/\text{H}_2$  system does not proceed spontaneously and until 1950 no satisfactory catalyst for the reaction was known. The discovery by Claeys, Dayton and Wilmarth (1950) that potassium amide was an efficient homogeneous catalyst renewed enthusiasm for the system. Both monothermal and bithermal operation of the process are feasible. Most current research into heavy water production is directed towards this system, and it is likely to be the most immediate challenger to the GS process.

The exchange rate of deuterium between hydrogen and ammonia even with the potassium amide catalyst is relatively slow. Reported values of Murphree plate efficiency in the range 0.50-24 per cent (Bigeleisen 1957, Bourke and Pepper 1963) contrast unfavourably with the value of 60-65 per cent for the GS process.

Though there have been several studies of the kinetics of the exchange reaction (Haul et al. 1961, Haul and Blennemann 1962, Rebora 1962, Bar-Eli and Klein 1962a, Dirian et al. 1963, Delmas 1968), no consistent or completely satisfactory explanation has emerged. At very low concentrations, the exchange rate is approximately proportional to catalyst concentration and is controlled by the rate of chemical reaction (Bar-Eli and Klein 1962a, Wilmarth and Dayton 1953). Wilmarth and Dayton suggested a mechanism of the form

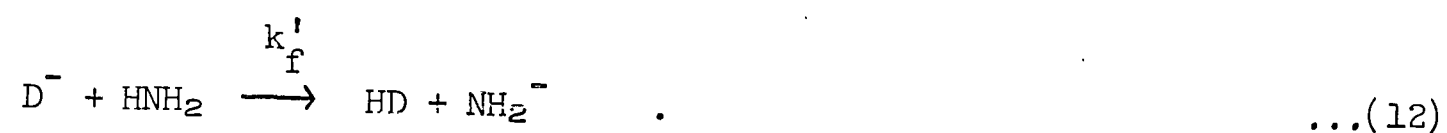

Bigeleisen (1957) subsequently established that for catalyst concentrations above 0.1 M  $\text{KNH}_2$  the reaction rate is at least partly controlled by the diffusion of hydrogen through the liquid film.

The studies of Bourke and Lee (1961) over the temperature range  $-40^\circ\text{C}$  to  $+20^\circ\text{C}$  indicated that for potassium amide concentrations of 36 g/litre the half-life for chemical reaction was of the order of 0.04-0.002 sec. Even so, the overall exchange rate was very slow because of the low solubility of hydrogen in ammonia. The overall mechanism is that of absorption with chemical reaction for which various treatments are available (for example, Danckwerts and Kennedy 1954; Sherwood and Pigford 1952). Bourke and Lee (1961) suggested an equation of the form

$$r = \frac{(c_i - c_o) A \sqrt{Dk}}{\tanh \frac{\sqrt{Dk}}{k_L}} \quad \dots(13)$$

where  $r$  is the rate of exchange,  $c_i$  is the solubility of HD in  $\text{NH}_3$ ,  $c_o$  is the equilibrium concentration of HD in  $\text{NH}_2\text{D}$ ,  $D$  is the diffusion coefficient of HD,  $A$  is the interfacial area,  $k$  is the chemical rate constant and  $k_L$  is the mass transfer coefficient without reaction.

According to Equation 13, several methods of increasing the rate of mass transfer are available:

(a) The solubility of hydrogen in ammonia could be increased. The most obvious way to do this is to increase the hydrogen pressure. Results of Haul et al. (1961) indicate that the exchange rate is a linear function of pressure. The A.E.C.L. study of the  $\text{NH}_3/\text{H}_2$  bithermal exchange scheme (Rae 1966) proposed a working pressure of 21 MN/m<sup>2</sup> (3,000 psia).

(b) The rate of chemical exchange could be improved if a higher catalyst concentration were used or if a more effective catalyst could be found. Lefrancois et al. (1962) established that rubidium and caesium amides are more efficient catalysts than potassium amide. These catalysts are also safer to handle and are very soluble in ammonia. Typical Murphree efficiencies are listed in Table 6. However the high cost of rubidium and caesium probably precludes their use.

(c) The cold tower temperature could be raised. While high temperatures are desirable for rapid mass transfer, the equilibrium is favoured by low temperatures. Cold tower temperature is limited, in theory, only by the freezing point of ammonia,  $-78^\circ\text{C}$ . However, kinetic studies indicate that the exchange rate is too low at temperatures near the freezing point. The activation energy for the exchange reaction has been variously reported as 3.9-8.0 kcal/mole (Haul et al. 1961; Bourke and Lee 1961). A temperature of  $-30^\circ\text{C}$  to  $-40^\circ\text{C}$  is probably the lower limit at present consistent with acceptable mass transfer rates (Bancroft 1968).

(d) Both the interfacial area and the mass transfer coefficient could be increased by better contacting. Mechanical agitation may be a relatively simple method of increasing turbulence and interfacial area. Voyer and Miller (1967) reported that the presence of screen packing in a column increased the interfacial area in a co-current gas-liquid contactor. The French plant at Mazingarbe relies on ejectors developed by Sulzer Brothers Ltd. to increase contact efficiency (LeFrancois 1968; Le Chatelier 1968). The gas entering the ejector sucks in liquid and forms an emulsion which exchanges rapidly in the reaction chamber before being separated. Pumps are required to circulate the liquid from one level to another. A schematic diagram of this arrangement is shown in Figure 4.

### 6.2.2 Production facilities and economics

The ammonia-hydrogen process requires a large source of either ammonia or hydrogen. Synthesis gas mixtures (75 per cent hydrogen and 25 per cent nitrogen by volume) for ammonia production are currently the largest sources of deuterium available. A plant to produce 400 tonnes/year of heavy water, a conventional size for GS plants, would have to be linked to a plant producing 6,000 tonnes/day of ammonia but no such plants are in existence. For some time, plants based on  $\text{NH}_3/\text{H}_2$  exchange will be limited to about 100 tonnes/year throughput corresponding to a 1,500 tonnes/day ammonia plant.

The first commercial  $\text{NH}_3/\text{H}_2$  plant, with a production capacity of 25 tonnes/year, began operation at Mazingarbe in 1967 (Ellwood 1968). French workers concluded that the monothermal version of the  $\text{NH}_3/\text{H}_2$  process offered the best prospects (Lefrancois et al. 1964) and this scheme was adopted for the Mazingarbe plant. India has recently decided to construct a 65 tonnes/year plant based on the French design (Prakash, BARC, private communication 1969).

A schematic diagram of the Mazingarbe plant is shown in Figure 5. Its features include a catalyst scrubbing tower to remove deuterium from the concentrated solution of potassium amide in ammonia; a thermal cracking unit to provide reflux hydrogen to the reaction towers and the Sulzer ejector contacting system described earlier. The exchange towers, fabricated from low alloy steel, are 1.6 metres in diameter, 36 metres high and weigh 240 tonnes (Ellwood 1968, Le Chatelier 1968). The product ammonia from the towers contains 1-3 per cent deuterium. Final enrichment to 98 per cent deuterium is via ammonia distillation.

Special precautions are required in handling the potassium amide catalysts at Mazingarbe (Roth 1968). Potassium amide is very sensitive to steam, which destroys it, forming the hydroxide, and to air, in which it is spontaneously flammable. The presence of large quantities of pressurised ammonia and hydrogen adds to the danger of explosion. Consequently the hydrogen feed gas must be pretreated and purified to rigorous standards.

Recycling of the amide catalyst poses some problems in a monothermal system. The catalyst may be either concentrated by evaporation of ammonia (Lazard and Lerat 1961, 1963) or amalgamated at a mercury electrode (Dirian and Sack 1963). In the former case, the enriched  $\text{KNH}_2\text{-NH}_3$  solution must be stripped of deuterium in a scrubbing tower before returning to the exchange column (Lazard 1965).

Monothermal operation has the advantage of a higher separation factor 5.8, with 83 per cent recovery of deuterium at  $-40^\circ\text{C}$ . This advantage is offset by the need to evaporate ammonia before cracking and to strip the catalyst of its deuterium. Despite the relatively low heat of decomposition of ammonia,

$3.0 \times 10^6$  J/kg, (1,300 Btu/lb) (Rae 1965), the cracking of ammonia represents the most costly unit operation. Power and steam requirements have been estimated to be 1,100 kWh and 2,800 kg steam per kg  $\text{D}_2\text{O}$  in the monothermal case but only 800 kWh and 1,400 kg steam per kg  $\text{D}_2\text{O}$  in the bithermal case (Law 1965). Consequently a pilot plant has been built in France to study the bithermal process (Rostaing 1968).

German research has shown that the dual temperature scheme is both feasible (Walter and Schindewolf 1965) and competitive (Becker et al. 1969). Pilot plant studies have been conducted at Friedrich Ude GmbH. This installation consists of two cold columns operating at  $-20^\circ\text{C}$  and a hot tower at  $60^\circ\text{C}$ . Each column has an internal diameter of 12 cm, contains about 200 sieve plates, and operates at a pressure of 20 MN/m<sup>2</sup> (200 atm.).

Recently Becker et al. (1969) published details of a design and cost study for a 100 tonnes/year plant using synthesis gas as feed. The plant design, based on the operational data of the German pilot plant, is shown in Figure 6 and a comparison of estimated production costs with those based on the Proctor and Thayer design for a 180 tonnes/year GS plant is given in Table 7. Although it is difficult to compare costs in different countries at different times, the  $\text{NH}_3/\text{H}_2$  process appears to be markedly superior overall. In regions of high energy costs, the superiority of the  $\text{NH}_3/\text{H}_2$  process would be even more evident. According to Becker et al. (1969), power and steam requirements for bithermal  $\text{NH}_3/\text{H}_2$  exchange are 560 kWh and 2,000 kg steam per kg  $\text{D}_2\text{O}$  and 265 kWh and 11,000 kg steam per kg  $\text{D}_2\text{O}$  for the GS process. On this basis, if the energy costs used in Table 6 were doubled, production costs would rise by \$3.44/kg  $\text{D}_2\text{O}$  for an  $\text{NH}_3/\text{H}_2$  plant and \$6.98/kg  $\text{D}_2\text{O}$  for a GS plant.

Unlimited production via the  $\text{NH}_3/\text{H}_2$  process might be achieved by using an equilibration stage in which either ammonia or hydrogen depleted in deuterium is exchanged with water. The separation factor for  $\text{NH}_3/\text{H}_2\text{O}$  exchange is close to unity and the structure of ammonia in water suggests that exchange would be rapid. However, the necessity of removing all the sensitive amide catalyst from the depleted ammonia stream and ensuring that the returning stream is completely dried would pose many problems. Further, the optimum molar gas/liquid flow rate in a dual temperature unit is of the same order as the separation factor (Bebbington and Thayer 1959, Pratt 1961), so that in the  $\text{NH}_3/\text{H}_2$  system the liquid circulation rate is only 15-25 per cent of the gas rate. On this basis replenishment of the hydrogen is fundamentally more desirable.

Equilibration via  $\text{H}_2\text{O}/\text{H}_2$  exchange has the disadvantage that no completely acceptable catalysts are currently available (see Section 6.3). The deuterium also tends to concentrate in the water so that best results are obtained at high

temperatures. At 200°C, the separation factor is ~ 2 and it is possible to raise the depleted hydrogen stream to 70 ppm (roughly half the natural abundance).

A cost study recently completed in Canada (Bancroft 1968) compared two possible plant designs based on NH<sub>3</sub>/H<sub>2</sub> dual temperature exchange; a 63 tonnes/year plant linked to a 900 tonnes/day ammonia plant and a 360 tonnes/year plant based on water equilibration of depleted hydrogen feed. Flowsheets for both processes are shown in Figures 7 and 8. A breakdown of costs for the 360 tonnes/year plant is given in Table 8. The results of this study indicated that water-based NH<sub>3</sub>/H<sub>2</sub> exchange was likely to produce heavy water for the same overall cost as the GS process. Operating costs were estimated to be only 71 per cent of those applicable to the GS process mainly because steam and power requirements were markedly less. Capital costs were higher because of the need for feed equilibration. An evaluation of the 63 tonnes/year plant with synthesis gas feed showed that, if the deuterium concentration of the feed was above 123 ppm, this scheme would be superior to a 360 tonnes/year plant based on either the GS process or the NH<sub>3</sub>/H<sub>2</sub> scheme with feed equilibration.

#### 6.2.3 Amine-hydrogen exchange

Amines have been proposed as additives or substitutes for ammonia in the NH<sub>3</sub>/H<sub>2</sub> process. Bar-Eli and Klein (1962b, 1965) discovered that the rate of exchange in amines was from five to ten times the rate found using ammonia. Kenyon and Pepper (1964) and Kenyon (1968) reached similar conclusions and proposed that pyrrolidine and dimethylamine were the most suitable amines but claimed that ethylamine, ethylenediamine and trimethylamine were not effective. This was disputed by French workers (CEA 1968) who claimed that trimethylamine enhanced contact efficiency. The reason for the increase in exchange rate in amine/ammonia mixtures has not been adequately explained, but it has been suggested that the amine increases the solubility of hydrogen in ammoniacal solutions (CEA 1968).

Apart from the more rapid exchange rate, the amine/H<sub>2</sub> system has the advantage of a lower vapour pressure so that lower pressures and higher hot tower temperatures can be used. Properties of some aliphatic amines are given in Table 9. Solubilities of hydrogen in amines and exchange rate constants have been extracted from the recent data of Rochard (1969). Separation factors for such systems have not so far been published.

#### 6.3 Hydrogen-Water Exchange

The separation factor for the H<sub>2</sub>O/H<sub>2</sub> exchange reaction

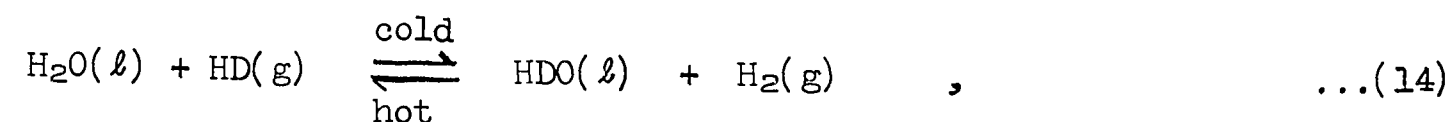

is slightly above that of the NH<sub>3</sub>/H<sub>2</sub> system and the temperature coefficient is

approximately the same. If water is used as a deuterium source, unlimited production is possible. However, while the H<sub>2</sub>O/H<sub>2</sub> system is in many ways the most suitable scheme for deuterium enrichment, the exchange does not proceed without a catalyst.

#### 6.3.1 Gas phase catalysis

Hydrogen/steam exchange was the first process selected for commercial development by the Manhattan District (Murphy 1955). A plant of 6 tonnes/year capacity was built at Trail, Canada and began operation in 1943. The exchange towers (Figure 9) contained alternative arrangements of bubble cap trays, where water and steam were equilibrated, and fixed catalyst beds where exchange took place. A steam-hydrogen mixture flowed upwards at 65°C through each tower, counter-current to a stream of water. The gas was heated before passing through each catalyst bed to prevent condensation. Platinum on activated charcoal and nickel on chromium oxide were used as catalysts. Reflux to the column was provided by electrolysis of the enriched water.

The capital cost of the Trail plant was \$US 2.4 million and operating costs in 1945 were \$US 60/kg D<sub>2</sub>O. Benedict examined the economics of heavy water production for a 9 tonnes/year unit and calculated that total production cost (including capital charges at 5 per cent) would be \$103/kg D<sub>2</sub>O (1954 US dollars). On these figures, gas phase catalysis is not economic.

One of the main reasons for the high production cost is the complexity of the column internals, notably the gas superheating stages. Also, the cost advantages of large-scale production cannot be obtained unless a profitable market for electrolytic hydrogen is available. In most countries electrolysis of water to produce hydrogen has been superseded. Other sources of hydrogen, such as synthesis gas, cannot be used because of catalyst poisoning. Dual temperature operation of Trail type towers is not possible. However, Cerrai et al. (1954) proposed a dual temperature system with a cold tower at around 70-100°C and a high temperature gas reaction chamber at 500°C but the scheme does not appear to be economic (Benedict 1955).

In 1956, the Trail plant was shut down. In Norway, where power costs are very low, steam/hydrogen exchange coupled with electrolysis is still used in three plants of total capacity 20 tonnes/year but the capital or operating costs have not been published.

#### 6.3.2 Liquid phase catalysis

(i) Heterogeneous catalysis: The original studies of steam/hydrogen exchange appeared to indicate that heterogeneous catalysts lost much of their activity when brought into contact with water (Benedict 1955). However later

work (Roth et al. 1958), indicated that the chemical activity in both phases was of the same order but in the case of liquid phase exchange the diffusion through the boundary layer was the limiting factor. Gas diffusion can be promoted by extensive catalyst dispersion, by better gas-liquid contacting and by raising the hydrogen solubility by increasing the pressure. French studies (Roth et al. 1958) found that colloidal platinum was by far the most active catalyst while Ni/Cr<sub>2</sub>O<sub>3</sub> and Pt/Al<sub>2</sub>O<sub>3</sub> granulated powders were also effective. The use of colloidal platinum would be restricted to processes in which water was the closed cycle because of the problems of recovery of catalyst. Catalyst inventory would contribute substantially to the capital cost and the resistance of the catalyst to poisoning would be important.

Becker (1956) and co-workers (1958a, 1958b, 1962) studied high pressure-liquid phase exchange on a platinum-charcoal suspended catalyst and estimated that power and heat requirements for a process based on hydrogen as a feed source would be 200 kWh and 2,100 kg of steam per kg D<sub>2</sub>O (compared with 265 kWh and 11,000 kg of steam per kg D<sub>2</sub>O for the GS process). The platinum inventory of 16 g per kg D<sub>2</sub>O/year represents a cost of about \$40 per kg D<sub>2</sub>O/year (Ayres 1969).

The dual temperature process suggested by Becker has been examined in a pilot plant built by Friedrich Uhde GmbH (Walter et al. 1962, Becker 1962). The temperature in the hot tower was set at 200°C while the two cold towers were maintained at 30°C. However, more encouraging results were later obtained in a study of the NH<sub>3</sub>/H<sub>2</sub> scheme in the same plant (see Section 6.2) and it was concluded that the NH<sub>3</sub>/H<sub>2</sub> route was likely to produce cheaper heavy water (Walter and Schindewolf 1965, Becker et al. 1969). Becker (1958b, 1962) considered that the most promising results for the H<sub>2</sub>(g)/H<sub>2</sub>O(l) exchange reaction would be obtained with a phase conversion system either by water electrolysis or by the water-gas shift reaction.

(ii) Homogeneous catalysis: The catalytic activity of the hydroxyl ion for H<sub>2</sub>/H<sub>2</sub>O exchange was discovered soon after the isolation of deuterium (Wirtz and Bonhoeffer 1936) and later, more extensive studies (Claeys et al. 1950, Wilmarth et al. 1953, Miller and Rittenberg 1958) have confirmed this result. The exchange rate is proportional to hydrogen pressure up to 10 MN/m<sup>2</sup> (100 atm.) and increases with sodium hydroxide concentration up to 5 molar. Schindewolf (1963) suggested a mechanism involving heterolytic scission of hydrogen, as follows:

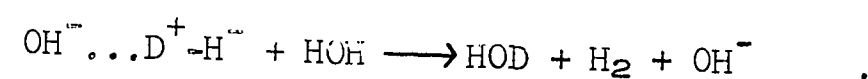

At 30°C, the exchange rate is much slower than the platinum catalysed reaction. However, as the activation energy for this reaction is about 24 kcal/mole

(Wilmarth et al. 1953), which corresponds to a doubling of the rate every 5-10°C, the exchange rate may be sufficiently large to be of use at much higher temperatures.

Sodium hydroxide is very corrosive at high temperatures and catalyst recovery could be costly. Ishida and Benedict (1964) studied the catalytic activity of an organic base diethylamine which would overcome these problems but unfortunately the exchange rate was too low to be of use. Hydrazine has been suggested as a homogeneous catalyst (Barr and Drews 1960) but Flournoy and Wilmarth (1961) indicated that the exchange rate in 60 per cent aqueous solutions of hydrazine and ethylenediamine was only comparable with the rate for 0.1 M KOH. Benedict (1965) reported that ferrous ion catalyses the exchange reaction and suggested that other paramagnetic ions or quaternary amines may be effective. Bacteria containing a hydrogenase enzyme catalyse H<sub>2</sub>/H<sub>2</sub>O exchange but the exchange rate at atmospheric pressure is very slow (Linday and Syrett 1960, Syrett 1961).

It has been reported that some transition metal complexes catalyse the H<sub>2</sub>/H<sub>2</sub>O exchange reaction (Schindewolf 1963, Halpern and James 1966). Table 10 compares the rate of exchange for ruthenium chloride and cobalt (II) cyanide complexes with the rate for other known catalysts. The exchange rates for these catalysts are not encouraging, particularly as catalyst inventory and recovery costs are likely to be important.

### 6.3.3 General process considerations

The economics of dual temperature H<sub>2</sub>/H<sub>2</sub>O exchange depend on the discovery of a catalyst which enables acceptable exchange rates to be obtained in the cold tower. In evaluating the relative merits of various catalysts the following factors need to be considered:

(a) Even if an extremely efficient heterogeneous catalyst is found, the mass transfer rate may be limited by either the diffusion of dissolved hydrogen from the gas-liquid interface to the bulk of the liquid or the diffusion of hydrogen from the bulk to the catalyst surface. Both processes are functions of the hydrogen solubility. At 200 atm. and 25°C, the solubility of hydrogen in water is only 0.15 moles/litre while the corresponding solubility in ammonia is 0.54 moles/litre (Stephen and Stephen 1963). As the solubility of hydrogen in ammonia limits the exchange rate in that system (Bancroft 1968), diffusion processes could be expected to be even more important in the H<sub>2</sub>/H<sub>2</sub>O system.

(b) The fundamental limitation described above can be overcome if a homogeneous catalyst is used. In this case the mass transfer rate is limited only by the chemical reaction rate (see Equation 13).

(c) The catalyst should ideally be cheap, easily recovered and resistant



to poisoning. Heterogeneous catalysts such as platinum on charcoal can be recovered easily but are expensive and easily poisoned. If a homogeneous catalyst is volatile and does not form an azeotrope with water it can generally be recovered cheaply by evaporation or by steam stripping. Ion exchange is usually more costly but not prohibitive. In some cases if the catalyst is relatively inexpensive, for example very dilute caustic soda, there may not be an economic necessity to recover the catalyst.

(d) Corrosion due to homogeneous catalysts may be a serious problem, for example, alkalis such as caustic soda are very corrosive especially at high temperatures.

The prospects of finding a cheap, homogeneous catalyst which is efficient at low temperatures do not appear to be bright. It is suggested however that any compound which catalyses a reaction in which hydrogen is reduced should be viewed as a potential catalyst for  $H_2/H_2O$  exchange.

#### 6.3 4 $H_2/H_2O$ exchange for feed equilibration

While dual temperature  $H_2/H_2O$  exchange does not appear to be economic at the present time, the transfer rate is sufficiently great at 200°C or above to consider equilibration of a depleted hydrogen feedstream. The replenished hydrogen could then be further enriched by  $NH_3/H_2$  exchange or by hydrogen distillation or adsorption processes. Besides the advantage of unlimited production, a pure hydrogen stream rather than a synthesis gas mixture ( $3H_2 + N_2$ ) could be the source of deuterium. Since the allowable gas velocity through a tower is proportional to the square root of the vapour density (Perry 1963), gas throughputs with pure hydrogen feed can be approximately doubled.

The Canadian study of  $NH_3/H_2$  exchange with feed equilibration has been discussed in Section 6.2. The design data for this study were based on an extrapolation of Becker's results using a platinum on charcoal catalyst (Becker et al. 1958a, 1958b) and can only be regarded as approximate. It was assumed that feed water would need to be very pure to prevent poisoning and that extensive recovery equipment for platinum would be required (Bancroft 1968). About 40 per cent of the total capital cost was accounted for in the  $H_2/H_2O$  exchange step (see Table 8).

Recently, Schindewolf and Hornke (1968) proposed that dilute caustic soda be used as a homogeneous catalyst for equilibration. At 240°C, a Murphree plate efficiency of 40 per cent was reported for 0.4 g/litre NaOH. Plate efficiency increased with temperature but decreased with caustic soda concentration below about 0.4 g/litre. Special materials would be required to prevent caustic corrosion but if the plate efficiencies reported can be obtained in conventional distillation equipment, only relatively few stages would be required to equilibrate the hydrogen feed.

## 6.4 Other Chemical Exchange Reactions

Many chemical exchange reactions are listed and discussed briefly by Barr and Drews (1960) in their survey of processes for heavy water production. Only a few of the more promising exchange reactions will be discussed here.

### 6.4.1 Phosphine/water exchange

The equilibrium constant for  $PH_3/H_2O$  exchange is reported to be about the same as the  $H_2S/H_2O$  system (Weston and Bigeleisen 1952) but the temperature coefficient is slightly lower (see Figure 2). However as phosphine carries 50 per cent more hydrogen per unit volume than hydrogen sulphide, tower volume can be reduced proportionately. The production rate of a plant operating on phosphine would be 35-40 per cent greater than the same plant operating on  $H_2S$  (Bigeleisen and Weston 1952, Bigeleisen 1957, Barr and Drews 1960).

$PH_3/H_2O$  exchange is normally very slow but is catalysed by both acids and bases (Weston and Bigeleisen 1954). At a pH of 2, Bigeleisen (1957) reported that the chemical rate is of the order of seconds but the half-life for exchange is of the order of hours at low pressures. It appears that, just as in the case of  $NH_3/H_2$  and  $H_2/H_2O$  exchange, the slow step is the diffusion of the gas into the liquid. However the solubility of phosphine in water is greater than that of hydrogen by an order of magnitude at 25°C (Lange 1956) and satisfactory tray efficiencies may be obtained at high pressures. Bigeleisen (1957) suggested that if 0.01 M sulphuric acid was used as the catalyst it could be discarded at a cost of \$4.40 per kg  $D_2O$ .

A  $PH_3/H_2O$  process would not be without special problems. Phosphine is more costly to produce than hydrogen sulphide, is just as toxic, and, at least in its impure state, is spontaneously flammable. The corrosiveness of the acid catalyst would necessitate the use of special materials. Alternatively it may be possible to employ cation exchange resins as fixed catalysts in the cold tower with a saving in materials and process chemical costs.

### 6.4.2 Halogen acids/water exchange

The separation factors for HCl, HBr and HI exchange in water are all above those for the  $H_2S/H_2O$  system (see Figure 2) while the HI/ $H_2O$  system appears to be particularly attractive. Equilibrium in these ionic solutions is reached very rapidly. However the halides carry only half as much hydrogen per molecule as either  $H_2S$  or  $H_2$  and all gas flow rates are effectively doubled. Tower requirements in dual temperature exchange are further increased because the halides are very soluble in the cold tower and because the vapour pressure in the hot tower is appreciable. Both these factors reduce the effective separation per stage (see Equation 6). Other problems arise due to the corrosiveness of the halogen

acids and because these acids form azeotropes with water.

Vaisberg and Varshavskii (1963) studied the HCl/H<sub>2</sub>O system in dual temperature operation between the temperatures of 17°C and 90°C and a design study for the HI/H<sub>2</sub>O system has been reported (Drews 1955, Barr and Drews 1960). In the latter study, it was assumed that a common ion solute could be used to destroy the HI/H<sub>2</sub>O azeotrope and to reduce the solubility of HI in water. Even with these assumptions, the HI/H<sub>2</sub>O scheme was found to be unattractive. However Drews (1955) concluded that a relatively small decrease in the solubilities and humidities assumed in the USAEC study could make the process competitive.

The feasibility of operating at temperatures of solid hydrate formation may be worth studying. All halogen acids form solid hydrates, for example, HI·2H<sub>2</sub>O, m.p. - 43°C; HCl·2H<sub>2</sub>O, m.p. - 18°C; HBr·4H<sub>2</sub>O, m.p. - 56°C (Mellor 1952). At -40°C extrapolation of existing data for the HI/H<sub>2</sub>O system gives  $\alpha \approx 6$ . If practicable, a flow scheme based on formation and subsequent decomposition of a hydrogen halide hydrate could be devised. Glew (1966) has proposed such a scheme for the hydrates of hydrogen sulphide.

#### 6.4.3 Alkanes/hydrogen exchange

The separation factors for hydrogen exchange with alkanes have been calculated by Varshavskii and Vaisberg (1955) to be about the same as that for water or ammonia (see Table 11). If hydrogen exchange with alkanes follows the general law that systems with similar separation factors also have similar temperature coefficients of  $\alpha$ , the enrichment per stage is likely to be large at low temperatures. Typical separation factors could be approximately 6 at -50°C, 12 at -100°C and 45 at -150°C but exchange rates at these low temperatures are likely to be very slow (Barr and Drews 1960). However, if satisfactory exchange rates could be obtained, natural gas which is the second largest source of deuterium would provide a convenient feed to a heavy water plant. Vapour or liquid phase exchange and monothermal or dual temperature operation all appear feasible. Because hydrogen is many times more soluble in alkanes than in water (Stephen and Stephen 1963), diffusion processes are not likely to limit the exchange rate in liquid phase exchange.

Barr and Drews (1960) noted that alkane/H<sub>2</sub> exchange rates are low and extensive decomposition may occur but existing experimental results are meagre. The catalytic activity of Pt and Pd alloys have been reported in the range 70-200°C (McKee and Norton 1964; McKee 1966). Even at these temperatures the exchange rates appear to be too low to be of use. Fundamental research on the CH<sub>4</sub>/H<sub>2</sub> system has recently been undertaken in Canada (Bancroft 1968).

## 6.5 Comparison of Chemical Exchange Processes

At present the three chemical exchange systems of most interest for heavy water production are H<sub>2</sub>S/H<sub>2</sub>O, H<sub>2</sub>/NH<sub>3</sub> and H<sub>2</sub>/H<sub>2</sub>O. Some overall characteristics of these systems are summarised in Table 12. It should be noted that the GS process has the highest energy requirement and the lowest overall separation factor of these processes. There appears to be little scope for reducing heavy water costs via the H<sub>2</sub>S/H<sub>2</sub>O route by modification of the GS process conditions. Future gains are likely to be modest and based on an optimisation of equipment size and performance.

French, Canadian and German research all indicate that NH<sub>3</sub>/H<sub>2</sub> exchange is at least competitive with the GS process in plant sizes of 70 tonnes/year or greater. There is still much scope for improvement in process and engineering design so the NH<sub>3</sub>/H<sub>2</sub> scheme is likely to become even more attractive. Limitation in hydrogen supply is at present the most serious drawback. If this problem is satisfactorily solved, the NH<sub>3</sub>/H<sub>2</sub> route to heavy water production may supersede the GS process.

The H<sub>2</sub>O/H<sub>2</sub> process has the lowest energy requirements and if a satisfactory liquid phase catalyst is discovered it would also be a very attractive process.

## 7. DISTILLATION

Fractional distillation methods for heavy water production are based on the small differences in the vapour pressure of isotopic species. If it is assumed that the vapour and liquid phases form ideal solutions, the separation factor for distillation is equal to the ratio of the vapour pressures of the two components. When a substance contains more than one atom of a particular isotope, the separation factor can be calculated approximately from the ratio of the vapour pressures of the pure isotopic species (Bigeleisen 1957; Benedict and Pigford 1957), for example, for water:

$$\alpha = \frac{P_{\text{H}_2\text{O}}}{P_{\text{HDO}}} = \frac{P_{\text{HDO}}}{P_{\text{D}_2\text{O}}} = \sqrt{\frac{P_{\text{H}_2\text{O}}}{P_{\text{D}_2\text{O}}}} \quad \dots(15)$$

The separation factors, as determined from Equation 15, for the distillation of the four principal sources of deuterium, hydrogen, water, ammonia and methane, are listed in Table 13. Because of deviations from ideality the separation factor for hydrogen distillation is actually some 5 per cent less than predicted from Equation 15, and shown in Table 13 (Becker 1962).

### 7.1 Hydrogen Distillation

The distillation of hydrogen is the most attractive distillation method of heavy water production, since the separation factor is the largest of all four



substances listed in Table 13 while the latent heat of vaporisation is the lowest. Over 90 per cent of the deuterium can be economically recovered and, because of the small hold-up, equilibrium conditions can be established in about a day (Malkov et al. 1958).

Hydrogen distillation was considered by the Manhattan Project but, although the process was considered promising, no plant was constructed because of the lack of engineering experience at extremely low temperatures (Murphy 1955). Small plants have since been constructed in Russia (Malkov et al. 1958), Switzerland (Hanny 1960), Germany (Lehmer et al. 1959) and France (Akar and Simonet 1958, Roth et al. 1958) while the largest plant, located in India, has a capacity of 14 tonnes/year (Gami et al. 1958; Gami and Rapial 1964). The total output of these plants is about 30 tonnes/year.

Special insulation techniques are required in all hydrogen distillation plants to prevent refrigeration losses and the hydrogen feed supply must be purified to prevent solidification on heat exchanger surfaces (Bailey 1958; Denton et al. 1958, 1959). Hydrogen boils quietly without foaming but overall plate efficiencies of only 30-40 per cent are obtained (Malkov et al. 1958, Roth et al. 1958, Gami and Rapial 1964). Electrolytic hydrogen is the most convenient feed, but electrolysis is not an economic method of hydrogen production in most countries. Ammonia synthesis gas is used in the German and French plants but extensive purification facilities are necessary.

Hydrogen exists in two forms, ortho-hydrogen and para-hydrogen. At ambient temperature, an equilibrium mixture consists of 25 per cent para-hydrogen but at the temperature of liquid hydrogen an equilibrium mixture would consist of almost 100 per cent para-H<sub>2</sub>. The transformation to para-H<sub>2</sub> is exothermic and the heat release of 240 cal/gram mole (Roth et al. 1958) is greater than the heat of vaporisation (see Table 13). Some precautions are therefore required to prevent contact of liquid hydrogen with substances which might catalyse this reaction. Para- and ferromagnetic substances including oxygen are reported to be effective catalysts (Becker 1962, Kanda et al. 1958).

When hydrogen at the natural abundance is distilled, HD is concentrated but, because of the low temperatures, disproportionation into H<sub>2</sub> and D<sub>2</sub> does not occur. Thus in the Indian plant, the primary distillation column produces about 95 per cent HD and 5 per cent H<sub>2</sub> (Gami and Rapial 1964). This mixture must then be heated to room temperature and passed over a 'Deoxo type M' catalyst where equilibration of H<sub>2</sub>, HD and D<sub>2</sub> occurs. A second distillation column enriches this mixture to 99.98 per cent D<sub>2</sub> and the product is then reacted with pure oxygen to produce 99.9 per cent D<sub>2</sub>O.

Power requirements for hydrogen distillation have been reported to lie in

the range 3,500 - 6,000 kWh per kg of D<sub>2</sub>O (Benedict 1955, Malkov et al. 1958, Akar and Simonet 1958). At an energy cost of 5 mills per kWh, a power requirement of 4,000 kWh per kg D<sub>2</sub>O corresponds to a cost of \$20/kg D<sub>2</sub>O. This compares unfavourably with energy costs of about \$7/kg and \$3.50/kg for the GS and NH<sub>3</sub>/H<sub>2</sub> processes respectively (see Table 7). Benedict (1955) estimated that operating costs for a 40 tonnes/year plant would be \$US 35/kg D<sub>2</sub>O while capital charges at 10 per cent would add another \$US 37/kg D<sub>2</sub>O to bring the production cost to \$US 72/kg D<sub>2</sub>O. Gami and Rapial (1964) reported operating costs of about \$US 18/kg D<sub>2</sub>O for a distillation unit using feed which had been enriched to 700 ppm in an electrolytic cascade.

Appreciable cost reductions could be anticipated if production capacity could be freed from the restrictions imposed by limitations on the supply of hydrogen. If a cheap method of hydrogen equilibration with water is developed, both hydrogen distillation and NH<sub>3</sub>/H<sub>2</sub> exchange would become attractive routes to heavy water production. Research workers in France, having studied both these methods, concluded that NH<sub>3</sub>/H<sub>2</sub> exchange has the best prospects (Lefrancois et al. 1964).

## 7.2 Water Distillation

Distillation of water is a particularly simple method of heavy water production but the enrichment per stage obtainable in practice is quite small. Although the separation factor is as high as 1.12 at a pressure of 4.6 mmHg, operation in this region is not practical because of excessive tower volumes and the pressure drop requirement through the column. Typical working pressures would be 60 and 250 mmHg at the head and the base of the columns respectively (Murphy 1955). The average separation factor for these conditions would then be about 1.05.

Water distillation was the method chosen in three small plants in the U.S.A. during World War II largely because little process development was required. Operating costs for these plants were \$US 400 kg/D<sub>2</sub>O (Murphy 1955). Benedict (1955) suggested two possible methods of utilising heat more efficiently to reduce costs, namely, using cheap exhaust steam from a power plant or using vapour recompression. Even with these and other modifications including the use of an efficient tower packing (Spraypak) developed by the UKAEA (McWilliams 1953; McWilliams et al. 1956), production costs were not competitive. About 180,000 kg of 152 kN/m<sup>2</sup> (22 psia) steam were required per kg of D<sub>2</sub>O, and even if this steam were as cheap as 33 cents/tonne, energy costs would still amount to \$60/kg D<sub>2</sub>O.

Ayres (1969) reported a scheme to produce heavy water as a byproduct of a large power plant. In the proposed scheme, turbine exhaust steam at pressures in the range 14-28 kN/m<sup>2</sup> (2-4 psia) is utilized as a cheap source of heat for large packed distillation columns. The performance of the tower packing would

be vital to the economic success of this method since channelling in packed towers can lead to a marked decrease in efficiency as tower diameter is increased. A design study backed by research and development to determine the characteristics of various packings is required to assess the economic possibilities of this method.

Distillation of water is of considerable interest for final enrichment and for upgrading of heavy water from nuclear reactors. The Dana and Savannah River plants both used water distillation for enrichment beyond 15 per cent  $D_2O$  and similar facilities are planned for the new Canadian plants (Nuclear Canada 1969c). Water distillation is dependable, simple and flexible in this range. As the distillation columns operate under vacuum in contrast to the high pressures of the GS process, loss of valuable product is avoided. The cost of final enrichment accounts for only 3-6 per cent of the total cost (Bebbington et al. 1959, Huber and Sperandio 1964).

The Savannah River distillation train contains six towers each about 80 feet high and containing over 70 plates. Packed towers are preferred for final concentration in 'Kuhn' columns designed by Sulzer Brothers Ltd. (Huber 1960, Huber and Sperandio 1964). A comparison of the performance of the Sulzer columns and Savannah River sieve plate columns is shown in Table 14.

### 7.3 Ammonia Distillation

Ammonia distillation has several distinct advantages over water distillation:

- (i) The latent heat/mole of hydrogen is only 40 per cent of that of water, making reboiler and condenser loads considerably less.
- (ii) At pressures of 1 atm. and above, the separation factor is greater than that of water. Operation at several atmospheres pressure is desirable to increase vapour density and reduce tower requirements.
- (iii) Ammonia carries 50 per cent more hydrogen than water. Vapour flow rates are reduced correspondingly.

The economics of ammonia distillation has been studied by Drews (1955) and by Gami et al. (1958). Drews considered two plant types, a parasitic unit operating in conjunction with an ammonia plant and a plant relying on feed equilibration via the  $NH_3/H_2O$  exchange reaction. Power requirements for a parasitic plant were estimated to be 3,400 kWh per kg  $D_2O$  (Gami et al. 1958).

Table 15 shows the results of the cost studies. Even in the most optimistic case, ammonia production is not competitive. Barr and Drews (1960) concluded that ammonia distillation would be of interest only if the separation factor was not given by the cube root of the vapour pressure ratio of the pure isotopic species,

$NH_3$  and  $ND_3$ , as assumed in their study. Subsequent results indicated that this assumption was correct (Petersen and Benedict 1963; Benedict 1965). Nevertheless, distillation of ammonia is attractive as a finishing operation for the same reasons that water distillation is attractive as a finishing operation in the GS process. Ammonia distillation is used to produce 99.75 per cent  $ND_3$  from a 1-2 per cent feed in the French  $NH_3/H_2$  exchange plant at Mazingarbe (Le Chatelier 1968).

### 7.4 Methane Distillation

The separation factors for methane distillation at atmospheric pressure or below are too low to be of use for heavy water production (Armstrong 1953, Armstrong et al. 1955, Drews 1955). Pogorski (1968) claimed, however, that the separation factor is more favourable at high pressures where the deuterated methanes are more volatile. According to Pogorski, the separation can be enhanced further by suitable additives or by application of external electric or magnetic forces. Experimental determinations of the differences in vapour pressures between deuterated and normal methanes are difficult to reconcile (Canadian Chemical Processing 1965, Pogorski 1968, Grigor and Steele 1968). The results of Pogorski for the monodeuterated  $CH_3D$  are compared with Grigor and Steele's data for the fully deuterated  $CD_4$  in Table 16. Some confusion exists in the literature as to whether Pogorski's data were obtained for a simple binary mixture, as suggested by the U.S. patent claim (Pogorski 1968), or in a more complex system (Canadian Chemical Processing 1965, Ayres 1969). If the vapour pressure ratios of deuterated methanes obey the geometric progression law at high pressures as they do at low pressures (Armstrong et al. 1955), a separation factor of about 0.991 could be expected from Grigor and Steele's results for pressures above 2 atm. (the separation factor is less than 1 because deuterium is enriched in the light phase). Pogorski's data, by contrast, indicate a separation factor in the range 0.82 - 0.96.

If the separation factors observed by Pogorski can be obtained in actual distillation columns, methane distillation could be an attractive route to heavy water production. Methane is attractive as a feed because it has a low latent heat and is present in large quantities in natural gas. Natural gas is frequently stored under pressure or liquefied so that power costs are likely to be low.

## 8. ELECTROLYTIC SEPARATIONS

### 8.1 Electrolysis of Water

When water is decomposed by electrolysis the deuterium concentration is increased in the residual solution and decreased in the hydrogen gas. It is

believed that this effect is partly due to the  $H_2/H_2O$  chemical exchange reaction and partly due to the relative rates of discharge of ions at the electrode surface and the subsequent formation and liberation of molecular hydrogen (Farkas 1935; Conway 1958, 1960). Separation factors in the range 3-10 are typically observed with the highest separation factors being obtained with low over-voltage metals (Walker 1961). Since these separation factors are generally greater than those observed in chemical exchange or distillation processes, electrolysis of water appears, at first sight, to be an ideal method of deuterium enrichment. Only 15 electrolytic stages are required to produce 99.7 per cent  $D_2O$  if the separation factor is 7 and, if the enriched hydrogen produced from the fourth and subsequent stages is burned and recycled, deuterium recovery is 33 per cent (Benedict and Pigford 1957).

Benedict (1955) has studied the economics of heavy water production and shown that power requirements would be about 125,000 kWh per kg  $D_2O$ . If electricity is produced for 4 mills/kWh the energy cost alone would be \$500/kg  $D_2O$ . Heavy water production via electrolysis of water can only be economic if the hydrogen produced can be sold competitively. Even if power costs are such that this condition can be met, the heavy water plant must bear the cost associated with the enriched hydrogen which is burned and recycled. The cost of this operation alone, assuming hydrogen has a value of 1.75 cents/ $m^3$  (\$0.50/1000 cu ft) is about \$30/kg  $D_2O$  (Benedict and Pigford 1957). Some thought has been given to recovery of much of this energy using fuel cells (Winsel 1963) or reversible electrolysis (Drews 1955), but no economic possibilities are foreseen (Barr and Drews 1960).

Although water electrolysis is not used at present as a direct method of heavy water production, it is used to produce an enriched hydrogen feed to a  $H_2$ /steam catalytic exchange unit in Norway and to hydrogen distillation plants in Russia, Switzerland and India (Becker 1962). These plants were discussed briefly in Sections 6.3 and 7.1. Electrolysis is also a simple and flexible method of reconcentrating downgraded heavy water from nuclear reactors. While water distillation is regarded as a better method for concentrations below 50 per cent  $D_2O$  (Bebbington et al. 1964), for concentrations above 90 per cent  $D_2O$  electrolysis appears to be the most suitable method of upgrading small quantities (up to several tonnes/year) of heavy water (Morrison et al. 1964, Saito et al. 1964).

### 8.2 Electrolysis of Ammonia

Separation factors of 15-30 have been claimed for the low temperature electrolysis of ammonia (Botter et al. 1963). While there is no possibility of producing heavy water economically solely by electrolysis of ammonia, electrolysis could be used to crack enriched ammonia to provide hydrogen reflux to an  $NH_3/H_2$  monothermal exchange unit or for the final concentration of the product following

$NH_3/H_2$  exchange. However, thermal cracking and ammonia distillation are preferred for these operations in the French plant at Mazingarbe (Ellwood 1968).

### 9. CHROMATOGRAPHIC SEPARATIONS

All separations which rely on partition of an isotopic mixture between a solution and an adsorbed phase are classified in this section as chromatographic processes. Little consideration has been given in the past to chromatographic or adsorption methods of deuterium enrichment and there is no agreement on the best mode of operation of such a system.

Gas chromatography has been used since 1952 as an analytical tool for separation of volatile components in a mixture. In 1956, Glueckauf and Kitt (1957a, 1957b) were able to separate deuterium and hydrogen at room temperature by displacement chromatography using a stationary phase of palladium on an asbestos support. Deuterium was the first component to appear and only two peaks corresponding to  $H_2$  and  $D_2$  were obtained because the palladium catalysed the conversion of HD to the pure isotopic species. Over the range 0-100°C the separation factor was given by

$$\log \alpha = \frac{215}{T} - 0.47 \quad \text{where } T \text{ is in } ^\circ K$$

According to this equation,  $\alpha$  is 1.3 at 100°C, 2.1 at 0°C and, extrapolating to lower temperatures,  $\alpha = 5.9$  at -100°C and 19 at -150°C. Thomas and Smith (1959) were able to separate the two hydrogen isotopes by elution chromatography, again using palladium as the stationary phase. While palladium appears to be a satisfactory adsorbent for  $H_2$ - $D_2$  separation (Lewis 1967, Botter et al. 1964), inventory requirements are almost certainly prohibitive. Other workers have demonstrated almost complete separation of the hydrogen isotopes at low temperatures (-200°C or less) using other stationary phases, namely, alumina (Venugopalan and Kutschke 1963; Hauback et al. 1967), alumina-chromic oxide (Smith and Hunt 1960) and silica gel (Hunt and Smith 1961). In all these separations, deuterium has the longest retention time. Deuterated methanes have also been separated at higher temperatures using charcoal (Gant and Yang 1964) and porous polymer beads (Czubryt and Gesser 1968) with the deuterated species appearing first in the effluent.

Chromatographic processes for isotope separation have the advantage that a large number of theoretical stages can be obtained in a small column. Until recently, however, the problems encountered in adapting such a system to a process scale unit seemed insurmountable. The chief difficulty was found in obtaining good resolution in large diameter columns because channelling effects and the axial velocity gradient across the column worked against separation.

West (1965) obtained satisfactory separation of  $H_2$ , HD and  $D_2$  at 77°K using a 0.68 in diameter column packed with ferric oxide treated alumina. Although column diameter could possibly be increased to 4 in without serious loss in efficiency, West considered that if capacity were to be increased further it would be more desirable to arrange a number of small diameter columns in parallel. Timmins and Ryan (1969) have reported that, if special baffles are used to promote radial mixing, column diameter can be increased to 4 feet. Column diameters of 10 feet or more have been projected (Chemical Processing 1969). Enrichment equivalent to one theoretical stage can be obtained for relatively large columns in a height of 0.2-1.0 cm (Timmins and Ryan 1969).

A schematic diagram of a chromatographic unit for large-scale production is shown in Figure 10a. As each product stream appears in the effluent it is detected and diverted to a recovery vessel where it is separated from the carrier gas which is then recycled. The feed to a chromatographic column for heavy water production could conceivably be any of the major sources of deuterium; hydrogen, methane, water or ammonia. Control of such a unit is likely to be complicated and the cost of product recovery will depend on the nature of the feed and the carrier gas.

Gas chromatography is essentially a batch operation, though it can be made continuous by cyclic operation (Thompson 1961). Even under these circumstances the column is never fully utilised because the carrier fluid will occupy a significant proportion of the total volume.

Some of the problems outlined above can be overcome if adsorption is carried out on a moving bed (Basmadjian 1960, 1963; Clayer et al. 1968). A schematic diagram of a moving-bed chromatographic unit as employed by Clayer et al. is shown in Figure 10b. The hydrogen feed is introduced between the adsorption and reflux zones and separation of the mixtures into its two components is achieved by counter-current exchange between the gas and the adsorbed phase of silica gel which flows downward by gravity in the moving bed. The displacement gas which, in this case, is nitrogen is introduced below the desorption zone and is adsorbed preferentially, replacing the deuterium-rich gas which is then displaced upwards into the reflux zone. For Clayer's experiments, the adsorption and reflux zones were maintained at -196°C and the desorption and purge zones at 180°C. The separation factor under these conditions was 1.5 and the height equivalent of an equilibrium stage (HETP) varied in the range 5-7 cm. The chief disadvantage of the moving bed unit proposed by Clayer is that refrigeration costs are very high because of the large temperature difference between the adsorption and desorption zones.

Drews (1955) studied the economics of heavy water production by adsorption

of hydrogen on a fixed charcoal bed at a low temperature followed by subsequent stripping at ambient temperatures to recover the deuterium-rich gas. The cost of char inventory was about \$US 12 per kg of  $D_2O$  and refrigeration costs were high. Barr and Drews (1960) concluded that such a system could only be economic if the separation factor was at least 100 at -240°C or 50 at -160°C. By contrast, Basmadjian (1960, 1963) reported that the separation factor on active carbon at -187°C was a mere 1.14.

Very little has been published on the enrichment of water by adsorption, ion-exchange or other chromatographic processes. Barr and Drews (1960) indicated that char adsorption of water could be an attractive method of feed pre-concentration. In their scheme which was based on the data of Aarii (1937), water was adsorbed at 30°C where the separation factor was 1.8 and desorbed at 100°C where the separation factor was 1.2. Kakihana (1963a, 1963b) indicated that water can be depleted in deuterium by contacting with a liquid or solid ion exchanger. Separation factors of about 1.5 at room temperature were claimed. The concentration of heavy water by this method does not appear to be due to ion exchange, but rather to the selective sorption of heavy water by the exchanger.

Because information such as exchange rates, separation factors, practical operating conditions and the most desirable method of contacting adsorbent and solution is largely lacking, it is difficult to assess the prospects of chromatographic separations as economic routes to heavy water production. In view of the current advances in production-scale chromatography, a re-examination of the prospects of this method seems worth while.

#### 10. CONCLUDING COMMENTS

Any physical or chemical differences in the properties of deuterium or hydrogen or their compounds can be used as a basis for the production of heavy water. Thus the literature contains hundreds of proposed methods which have not been discussed here. Most of these schemes can be eliminated on economic grounds because separation factors are inadequate, energy costs are excessive or because the methods cannot be efficiently adapted to large scale production.

Chemical exchange schemes for heavy water production are most attractive since a high degree of reversibility can be achieved and they are easily adapted to the process industry. The GS-process will remain an attractive scheme but, for fundamental reasons, the scope for further improvements is limited. Two exchange reactions;  $NH_3/H_2$  and  $H_2O/H_2$ , appear to be particularly promising for further development because they have a far greater elementary isotope shift. Amine/ $H_2$  exchange also appears to have promise because exchange rates are reportedly higher than those for  $NH_3/H_2$  exchange and it would be possible to operate a bithermal unit at a higher hot tower temperature or a lower pressure.



A scheme to produce heavy water based on the  $H_2O/H_2$  exchange reaction would be highly competitive if a satisfactory liquid phase catalyst were discovered. Even if such a catalyst cannot be found, high temperature  $H_2O/H_2$  exchange could be used to provide an unlimited hydrogen stream which is further enriched via another process such as  $NH_3/H_2$  exchange or  $H_2$  distillation.

Distillation of water, methane and hydrogen all appear to have some prospects of economic success. Processes for heavy water production based on chromatography or selective adsorption have received scant attention in the past. Many problems would need to be overcome before these processes can be adapted to large-scale production of heavy water but, in view of recent advances in plant scale chromatography, they should be re-examined.

#### 11. ACKNOWLEDGEMENT

The author wishes to acknowledge valuable discussions with Mr. P. G. Alfredson during the preparation of this report.

#### 12. REFERENCES

- Akar, P. and Simonet, G. (1958). - Industrial production of heavy water by distillation of liquid hydrogen; Proc. 2nd Int. Conf. on Peaceful Uses of Atomic Energy, 4 : 522-526.
- Arii, K. (1937). - Sorption of heavy water vapour by active charcoal. Bull. Inst. Phys. Chem. Research (Tokyo) 16 : 749-56.
- Armstrong, G. T. (1953). - A compilation of vapour pressure data of deuterium compounds. National Bureau of Standards Report (U.S.A.) NBS-2306.
- Armstrong, G. T., Brickwedde, F. G. and Scott, R. B. (1955). - Vapour pressure of methanes. J. Res. Nat. Bureau of Standards (U.S.A.) 55 (1) : 39-52.
- Ayres, J. A. (1969). - Production of heavy water: status report. BNWL-884.
- Bailey, B. M. (1958). - Some aspects of heavy water production by distillation of hydrogen; Proc. 2nd Int. Conf. on Peaceful Uses of Atomic Energy, 4 : 556-559.
- Bancroft, A. R. (1968). - The Canadian approach to cheaper heavy water (1967) AECL-3044.
- Bancroft, A. R. and Brown, R. M. (1967). - A programme to survey Canadian deuterium sources. AECL-2747.
- Bar-Eli, K. and Klein, F. S. (1962a). - Isotopic exchange between gaseous hydrogen and liquid ammonia: Part I. J. Chem. Soc: 1378-85.
- Bar-Eli, K. and Klein, F. S. (1962b). - Isotopic exchange of gaseous hydrogen with liquid aliphatic amines: Part II. J. Chem. Soc: 3083-88.
- Bar-Eli, K. and Klein, F. S. (1965). - Enrichment of deuterium. Canadian patent 719,200.

- Barr, F. T. (1966). - Heavy water production. Report of A.I.F. Ad Hoc Committee - April 1966.
- Barr, F. T. and Drews, W. T. (1960). - The future of cheap heavy water. Chem. Eng. Progr. 56(3):49-56.
- Basmadjian, D. (1960). - Adsorption equilibria of  $H_2$ ,  $D_2$  and their mixtures. Can. J. Chem. Part 1 38:141-148, Part 2 38:149-156.
- Basmadjian, D. (1963). - The separation of  $H_2$  and  $D_2$  by moving-bed adsorption: corroboration of adsorber design equations. Can. J. Chem. Eng. 41:269-272.
- Bebbington, W. P., Proctor, J. F., Scotten, W. C. and Thayer, V. R. (1964). - Production of heavy water in U.S.A., Proc. 3rd Int. Conf. on Peaceful Uses of Atomic Energy 12:334-339.
- Bebbington, W. P. and Thayer, V. R. (1959). - Production of heavy water. Chem. Eng. Progr. 55(9):70-78.
- Bebbington, W. P., Thayer, V. R. and Proctor, J. F. (1959). - Production of heavy water. Savannah River and Dana plants. Technical Manual. DP-400.
- Becker, E. W. (1956). - The preparation of heavy water. Angew. Chemie. 68(1):6-13. (Translation: AERE Lib/Trans 734).
- Becker, E. W. (1962). - Heavy water production. IAEA Review series No. 21.
- Becker, E. W., Bier, K., Hubener, R. P. and Kessler, R. W. (1958a). - The enrichment of heavy water by high pressure exchange between hydrogen and an aqueous suspension of a catalyst, Proc. 2nd Int. Conf. on Peaceful Uses of Atomic Energy, 4:543-49.
- Becker, E. W., Hubener, R. and Kessler, R. W. (1958b). - The enrichment of heavy water by high pressure exchange between hydrogen and an aqueous catalyst suspension. Chem. Ingr. Tech. 30(5):288-96. (Translation: AERE Lib/Trans. 799).
- Becker, E. W., Kessler, R. and Hubener, R. P. (1962). - Enrichment of heavy water by high pressure exchange between  $H_2$  and an aqueous catalyst suspension. Part 3: Effects of specific exchange performance and additives. Chem. Ingr. Tech. 34(2):105-108.
- Becker, E. W., Lange, G. and Schindewolfe, U. (1969). -  $D_2O$  supply by the hydrogen-ammonia, dual temperature process. Atomwirtschaft May 1969:257-260. Translation: AAEC Report (Lib/Trans. 224).
- Benedict, M. (1955). - Survey of  $D_2O$  processes, Proc. 1st Int. Conf. on Peaceful Uses of Atomic Energy, 8:377-405.
- Benedict, M. and Pigford, T. H. (1957). - Nuclear Chemical Engineering, McGraw-Hill, N.Y.
- Benedict, M. (1965). - Deuterium separation by ammonia distillation and hydrogen-water exchange. MIT-2249-2.

- Bigeleisen, J. (1957). - The significance of the product and sum rules to isotope fractionation processes. Proceedings of the Symposium on Isotope Separation. p.121-151. North Holland Publishing Co. Amsterdam.
- Bigeleisen, J. and Weston, R. E. (1952). - An evaluation of the feasibility of utilizing the exchange of hydrogen between phosphine and water for the production of heavy water. BNL-156.
- Botter, F., Dirian, G., Sack, H. and Lefrancois, B. (1963). - Process for the isotopic enrichment or fractionation of hydrogen. Canadian patent 664,835.
- Botter, F., Molinari, P. and Dirian, G. (1964). - Physico-chemical separation of stable isotopes: Laboratory and pilot plant studies. Proc. 3rd Int. Conf. on Peaceful Uses of Atomic Energy. 12:430-38.
- Bourke, P. J. and Lee, J. C. (1961). - Exchange of deuterium between hydrogen and liquid ammonia. Trans. Instn. Chem. Engrs. 39:280-287.
- Bourke, P. J. and Pepper, D. (1963). - Gas absorption performance of a bubble column. Trans. Instn. Chem. Engrs. 41:40-50.
- Brown, R. M., Stevens, W. H. and Thurston, W. M. (1967). - Deuterium content of Canadian waters - I. A collection of data available as of February 1967. AECL-2697.
- Canadian Chemical Processing (1965). - B-A oil proposes D<sub>2</sub>O from methane. 49(8):47-56.
- Canadian Chemical Processing (1967). - Sea water to feed heavy water plant, 51(6):41-46.
- Canadian Nuclear Technology (1966). - Canso N.S. site for heavy water plant. 5(4):30.
- C.E.A. (1968). Improved process for effecting isotopic exchange in a medium containing ammonia. U.K. patent 1,125,670, (assigned to Commissariat a l'Energie Atomique).
- Cerrai, E., Marchetti, C., Renzoni, R., Roseo, L., Silvestri, M. and Villani, S. (1954). - A thermal method for concentrating heavy water. Chem. Eng. Progr. Symp. Series. 50(39):271-280.
- Chemical Processing. (1969). - Production scale chromatography, 15(7):16-17.
- Claeys, Y., Dayton, J. and Wilmarth, W. K. (1950). - Hydrogen exchange of alkali amides and hydroxide with deuterium gas. J. Chem. Phys. 18:759.
- Clayer, A., Agneray, L., Vandenbussche, G. and Petel, P. (1968). - Preparation of hydrogen isotopes by chromatography in a moving bed. Z. Anal. Chem. 236:240-49. (Translation: AEC-TR-6998).
- Cochran, D. R. (1966). - The role and requirements of heavy water in Canada and the world. C.N.A. Conf. Winnipeg, Canada. May-June, 1966. 66-CNA-301.
- Conway, B. E. (1958). - The electrolytic hydrogen-deuterium separation factor and reaction mechanism. Proc. Roy. Soc. (London). A247:400-419.
- Conway, B. E. (1960). - Kinetics of electrolytic hydrogen and deuterium evolution. Proc. Roy. Soc. (London). A256:128-144.
- Czubryt, J. J. and Gesser, H. P. (1968). - Separation of CH<sub>4</sub> and CD<sub>4</sub> using porous polymer beads. J. Gas Chromatography. 6:41-42.

- Danckwerts, P. V. and Kennedy, A. M. (1954). - Kinetics of liquid-film process in gas absorption - Part I: Models of the absorption process. Trans. Instn. Chem. Engrs. 32:S49-S52.
- Delmas, R. (1968). - Isotopic exchange between molecular hydrogen and liquid ammonia catalysed by alkali amides. CEA-R-3377. (Translation: AAEC Report Lib/Trans. 213).
- Denton, W. H., Shaw, B. and Ward, D. E. (1958). - Purification of hydrogen for distillation - Part I. Trans. Instn. Chem. Engrs. 36:179-200.
- Denton, W. H., Shaw, B. and Ward, D. E. (1959). - Purification of hydrogen for distillation - Part II. Trans. Instn. Chem. Engrs. 37:277-288.
- Dirian, G., Botter, F., Ravoire, J. and Grandcollet, P. (1963). - Kinetics and mechanism of the exchange between liquid ammonia and hydrogen in the presence of potassium amide. J. Chim. Phys. 60:139-147.
- Dirian, G. and Sack, H. (1963). - Catalyst recovery in deuterium enrichment process. Canadian patent 656,471.
- Drews, W. P. (1955). - Deuterium separation study. Progress report No. 2 NYO-6085 (Rev).
- Ellwood, P. (1968). - New low-energy process makes impact on heavy water production. Chem. Eng. 75(14):56-58.
- Farkas, A. (1935). - Orthohydrogen, Parahydrogen and Heavy Hydrogen. Cambridge University Press, London.
- Flournoy, J. M. and Wilmarth, W. K. (1961). - The base catalysed exchange of hydrogen gas and protonic solvents III: the catalytic efficiency of concentrated aqueous alkali. J. Am. Chem. Soc. 83:2257-62.
- Gami, D. C., Gupta, D., Prasad, N. B. and Sharma, K. C. (1958). - Production of heavy water in India, Proc. 2nd Int. Conf. on Peaceful Uses of Atomic Energy, 4:534-39.
- Gami, D. C. and Rapial, A. S. (1964). - Analysis of operating experience of a hydrogen distillation plant, Proc. 3rd Int. Conf. on Peaceful Uses of Atomic Energy, 12:421-28.
- Gant, P. L. and Yang, K. (1964). - Chromatographic separation of isotopic methanes. J. Am. Chem. Soc. 86:5063-64.
- Garvin, R. G. and Norton, E. R. (1967). - Performance of sieve trays under GS heavy water process conditions - Part II: High pressure operation. DP-1025.
- Garvin, R. G. and Norton, E. R. (1968). - Sieve tray performance under GS process conditions. Chem. Eng. Progr. 64(3):99-106.
- Glew, D. N. (1966). - Process for isotope concentration. Canadian patent, 727,029.
- Glueckauf, E. and Kitt, G. P. (1957a). - Gas chromatographic separation of hydrogen isotopes, in Vapour Phase Chromatography (Ed. Desty, D.H.) pp.422-427. Butterworths, London.



- Glueckauf, E. and Kitt, G. P. (1957b). - Gas chromatographic separation of hydrogen isotopes. Proceedings of Symposium on Isotope Separation, pp.210-225, North Holland Publishing Co., Amsterdam.
- Grigor, A. F. and Steele, W. A. (1968). - Physical properties of fluid  $\text{CH}_4$  and  $\text{CD}_4$ : Experimental. J. Chem. Phys. 48(3):1032-1037.
- Halpern, J. and James, B. J. (1966). - Homogeneous catalysis of  $\text{D}_2/\text{H}_2\text{O}$  exchange by Ruthenium (III) Chloride: Evidence for heterolytic splitting of  $\text{H}_2$ . Can. J. Chem. 44:671-75.
- Hanny, J. (1960). - A low temperature plant for the production of heavy water. Sulzer Technical Review, 42(2):9-24.
- Hauback, W. J., Knobler, C. M., Katorski, A. and White, D. (1967). - The low temperature chromatographic separation of the isotopic hydrogens at 27 and 55°K. J. Phys. Chem. 71:1398-1402.
- Haul, R. and Blennemann, D. (1962). - Kinetics of isotope exchange between hydrogen and liquid ammonia on heterogeneous catalysts. J. Catalysis, 1:432-442. See also Jul-106-PC (Feb. 1963).
- Haul, R., Ihle, H., Schierholz, H. and Blennemann, D. (1961). - Deuterium exchange between hydrogen and liquid ammonia with potassium amide as catalyst. Chem. Ingr. Tech. 33(11):713-18.
- Huber, M. (1960). - Sulzer rectifying columns. Sulzer Technical Review. 42(2):25-34.
- Huber, M. and Sperandio, A. (1964). - Sulzer rectification plants for separating  $\text{D}_2\text{O}$  from  $\text{H}_2\text{O}$ . Sulzer Technical Review 46(3):1-12.
- Hunt, P. P. and Smith, H. A. (1961). - Separation of  $\text{H}_2$ , HD and  $\text{D}_2$  by gas chromatography. J. Phys. Chem. 65:87-9.
- Ishida, T. and Benedict, M. (1964). - Rate of exchange of deuterium between water and dissolved hydrogen in the presence of dimethylamine. MIT-2249-1.
- Kakihana, H. (1963a). - A method of concentrating heavy water by a liquid ion exchanger. Japanese patent 19101/1963. (Translation: ORNL-tr-332).
- Kakihana, H. (1963b). - A method of concentrating heavy water by an inorganic ion exchanger. Japanese patent 19102/1963. (Translation: ORNL-tr-333).
- Kanda, E., Sato, S., Sato, T., Monna, G., Tashiro, T., Kubota, M. and Matsugashita, T. (1958). - Experimental research on the rectification of liquid hydrogen to obtain deuterium, Proc. 2nd Int. Conf. on Peaceful Uses of Atomic Energy, 4:550-556.
- Kenyon, A. R. and Pepper, D. (1964). - New catalysts for the exchange of deuterium between hydrogen gas and liquid ammonia. J. Appl. Chem. 14:399-405.
- Kenyon, A. R. (1968). - Deuterium concentration processes. U.S. patent, 3,377,135.
- Lange, N. A. (1956). - Handbook of Chemistry. 9th Edn. Handbook Publishers Inc. Ohio. U.S.A.
- Law, C. A. (1965). - Heavy water: Western Deuterium's new tack. Canadian Nuclear Technology, Spring 1965:39-40.

- Law, C. A. (1968). - Heavy water production. Nucl. Eng. 13:510-512.
- Lazard, B. (1965). - Processes and apparatus for preparing heavy water by isotopic monothermic ammonia-hydrogen exchange. Canadian patent 701,780.
- Lazard, B. and Lerat, J. M. (1961). - Methods and devices for isotopic enrichment. Canadian patent 630,236.
- Lazard, B. and Lerat, J. M. (1963). - Isotopic exchange in the presence of a non-volatile catalyst. Canadian patent 656,855.
- Le Chatelier, J. (1968). - Heavy water plants based on the  $\text{NH}_3\text{-H}_2$  process. Bull. Inf. Sci. Tech. (Paris) No.123:21-26. (Translation: AAEC Report Lib/Trans. 167).
- Lefrancois, B. (1968). - The Mazingarbe heavy water plant. Bull. Inf. Sci. Tech. (Paris) No.123:11-20. (Translation: AAEC Report Lib/Trans. 166).
- Lefrancois, B., Lerat, J. M. and Roth, E. (1964). - Study of heavy water production in France, Proc. 3rd Int. Conf. on Peaceful Uses of Atomic Energy, 12:382-87.
- Lefrancois, B., Sack, H., Vaniscotte, C. and Dirian, G. (1962). - Caesium and rubidium catalysts in deuterium enriching process. Canadian patent 637,770.
- Lehmer, W., Sellmaier, A. and Baldus, W. (1959). - Production of heavy hydrogen in a large scale rectification plant. Linde. Ber. Tech. U Wiss. 5:3-14. (Translation: NP-tr-417).
- Lewis, F. A. (1967). - The Palladium-Hydrogen System, Academic Press, London.
- Lindsay, E. M. and Syrett, P. J. (1960). - An attempt to determine discriminate use of hydrogen isotopes by bacteria. J. Biochem. Microbiol. (Tech. Eng.) 2:25-29.
- McKee, D. W. and Norton, F. J. (1964). - Catalytic exchange of methane and deuterium on platinum, ruthenium and platinum - ruthenium alloys. J. Phys. Chem. 68(3):481-9.
- McKee, D. W. (1966). - Catalytic exchange of methane with deuterium on palladium - gold alloys. J. Phys. Chem. 70(2):525-530.
- McWilliams, J. A. (1953). - British patent 729,587.
- McWilliams, J. A., Pratt, H. R. C., Dell, F. R. and Jones, D. A. (1956). - Spraypak: A new industrial distillation and absorption tower packing. Trans. Instn. Chem. Engrs. 34:17-43.
- Malkov, M. P., Zeldovich, A. G., Fradkov, A. B. and Danilov, I. B. (1958). - Industrial separation of deuterium by low temperature distillation, Proc. 2nd Int. Conf. on Peaceful Uses of Atomic Energy, 4:491-98.
- Mellor, J. W. (1952). - A comprehensive treatise on inorganic and theoretical chemistry, Volume II. Longmans, London.
- Miller, S. L. and Rittenberg, D. (1958). - The catalysis of  $\text{H}_2\text{-D}_2\text{O}$  exchange by aqueous buffer solutions. J. Am. Chem. Soc. 80:64-65.

- Morris, J. W. and Scotten, W. C. (1962). - Control of the dual temperature exchange process for the manufacture of heavy water. Chem. Eng. Progr. Symp. Series, 58(39):26-38.
- Morrison, J. A., Thomas, M. H., Watson, L. C. and Woodhead, L. W. (1964). - The management of heavy water for research and power reactors, Proc. 3rd Int. Conf. on Peaceful Uses of Atomic Energy, 12:389-95.
- Murphy, G. M. (Ed.) (1955). - Production of heavy water. McGraw-Hill, N.Y.
- Nuclear Canada (1968). - India will use RAPP-1 as dual purpose plant, making heavy water next door, 7(11):9.
- Nuclear Canada (1969a). - Excess corrosion is latest obstacle to early production at Shallowford plant, 8(2):4-5.
- Nuclear Canada (1969b). - AECL to double size of Douglas Point heavy water plant, 8(3):1.
- Nuclear Canada (1969c). - Review of Du Pont group report as released to public, 8(10):6-11.
- Perry, J. H. (1963). - Chemical Engineer's Handbook, 4th Edn. McGraw-Hill, N.Y.
- Peterson, G. T. and Benedict, M. (1963). - Deuterium enrichment in the distillation of ammonia. Nucl. Sci. and Eng. 15:90-97.
- Pogorski, L. A. (1968). - Method for production of deuterated methanes and heavy water. United States patent 3,399,967.
- Pratt, H. R. C. (1961). - Dual temperature exchange, in Separation of Isotopes (London, H. - Ed.) Newnes Ltd., London.
- Proctor, J. F. (1963). - A new look at distillation - 2. Sieve and bubble-cap plates ..... comparative performance. Chem. Eng. Progr. 59(3):47-54.
- Proctor, J. F. and Thayer, V. R. (1961). - The economics of heavy water production, TID-13,964.
- Proctor, J. F. and Thayer, V. R. (1962a). - Economics of heavy water production. Chem. Eng. Progr. 58(4):53-61.
- Proctor, J. F. and Thayer, V. R. (1962b). - Flowsheets and supplementary data for the heavy water plant described in Chem. Eng. Progr. 58(4):53-61. TID-15,733.
- Rae, H. K. (1965). - A review of heavy water production processes. AECL-2503.
- Rae, H. K. (1966). - Chemical exchange processes for heavy water. AECL-2555.
- Ravoire, J., Grandcollot, P. and Dirian, G. (1963). - Determination of the separation factor of deuterium between ammonia and hydrogen. J. Chim. Phys. 60:130-138.
- Rebora, P. (1962). - The isotope exchange between gaseous hydrogen and liquid ammonia. Energia Nucleare (Milan). Part 1 - The kinetics of exchange in a bubbling contactor. 9:388-96. Part 2 - The kinetics of exchange in a packed column. 9:621-28.
- Rochard, E. (1969). - Isotope exchange between hydrogen and amines catalysed by alkali alkylamides. CEA-R-3835.

- Rostaing, M. (1968). - A pilot plant for dual temperature exchange for developmental studies of the  $\text{NH}_3\text{-H}_2$  process. Bull. Inf. Sci. Tech. (Paris). No. 123:27-30. (Translation: AAEC Report Lib/Trans. 171).
- Roth, E. (1968). - The isotopic exchange of deuterium between ammonia and hydrogen. A new process for the production of heavy water. Bull. Inf. Sci. Tech. (Paris) No. 123:3-10. (Translation: AAEC Report Lib/Trans. 163).
- Roth, E., Stouls, L., Dirian, G., Lazard, B. and Nief, G. (1958). - Production of heavy water in France, Proc. 2nd Int. Conf. on Peaceful Uses of Atomic Energy, 4:499-521.
- Ryan, R. K. (1967). - A brief survey of processes for heavy water production. AAEC/TM368.
- Saito, T., Sonoda, S., Kurihara, Y., Takamatsu, T. and Morita, T. (1964). - Commercial technical methods for reconcentration and purification of downgraded and contaminated heavy water for nuclear reactors. Proc. 3rd Int. Conf. on Peaceful Uses of Atomic Energy, 12:389-95.
- Schindewolf, U. (1963). - The homogeneous catalysis of the isotope exchange between hydrogen and liquid water. J. Chim. Phys. 60:124-129.
- Schindewolf, U. and Hornke, J. (1968). - Sodium hydroxide solutions as catalysts for the isotopic exchange between hydrogen and water in a transfer column for deuterium enrichment. Chem. Ingr. Tech. 40:29-30. (Translation: AAEC Report Lib/Trans. 212).
- Sherwood, T. K. and Pigford, R. L. (1952). - Absorption and Extraction. McGraw-Hill. N.Y.
- Smith, H. A. and Hunt, P. P. (1960). - Separation of  $\text{H}_2$ , HD and  $\text{D}_2$  by gas chromatography. J. Phys. Chem. 64:383-4.
- Spevack, J. S. (1957). - Method of isotope separation. U.S. patent 2,787,526.
- Spevack, J. S. (1959). - Isotope concentration system. U.S. patent 2,895,803.
- Stephen, H. and Stephen, T. (1963). - Solubilities of inorganic and organic compounds, Vol. 1. Binary Systems, Part 1. Pergamon Press, London.
- Syrett, P. J. (1961). - Biological processes, in Separation of Isotopes. (London, H. - Ed.) Newnes Ltd., London.
- Thayer, V. R. and De Long, W. B. (1962). - Materials of construction for the dual temperature exchange process for producing heavy water. Chem. Eng. Progr. Symposium Series, 58(39):86-93.
- Thomas, C. O. and Smith, H. A. (1959). - Gas chromatography with hydrogen and deuterium. J. Phys. Chem. 63:427-32.
- Thompson, D. W. (1961). - A continuous chromatographic separation process. Trans. Instn. Chem. Engrs. 39:289-298.
- Timmins, R. S. and Ryan, J. M. (1969). - Large scale chromatography: new separation tool. Chem. Eng. 76(11):170-77.

- Urey, H. C. (1947). - The thermodynamic properties of isotopic substances. *J. Chem. Soc.* 562-581.
- USAEC (1969). - AEC to increase price of heavy water. Press release No. M-272, Dec. 10, 1969.
- Vaisberg, S. E. and Varshavskii, M. (1963). - Dual temperature exchange of deuterium in the system water-hydrochloric acid. *Zh. Fiz. Khim.* 37:307-309.
- Varshavskii, M. and Vaisberg, S. E. (1955). - On the distribution of deuterium during isotopic exchange with hydrogen. *J. Chemical Physics. USSR* 29(3):523-32.
- Venugopalan, M. and Kutschke, K. O. (1963). - Gas chromatographic separation of hydrogen isotopes on activated alumina. *Can. J. Chem.* 41:548-9.
- Voyer, R. D. and Miller, A. I. (1967). - Improved gas-liquid contacting in co-current flow, AECL-2765. See also *Can. J. Chem. Eng.* 46:335-41(1968).
- Walker, P. T. (1961). - Electrolysis, in *Separation of Isotopes* (London, H. - Ed.) Newnes Ltd., London.
- Walter, S., Nitschke, E. and Bode, C. (1962). - The enrichment of heavy water by high pressure exchange between hydrogen and an aqueous suspension of a catalyst, Part 2: Construction and operation of a pilot plant. *Chem. Ingr. Tech.* 34(1):7-10. (Translation: AAEC Report Lib/Trans. 216).
- Walter, S. and Schindewolf, U. (1965). - Enrichment of deuterium by high pressure isotopic exchange between hydrogen and liquid ammonia in a dual temperature plant. *Chem. Ingr. Tech.* 37:1185-91. (Translation: AAEC Report Lib/Trans. 225).
- West, D. L. (1965). - Process scale separation of hydrogen isotopes by gas chromatography. DP-979.
- Weston, R. E. and Bigeleisen, J. (1952). - Equilibrium in the exchange of hydrogen between phosphine and water. *J. Chem. Phys.* 20(9):1400-1402.
- Weston, R. E. and Bigeleisen, J. (1954). - Kinetics of the exchange of hydrogen between phosphine and water: A kinetic estimate of the acid and base strengths of phosphine. *J. Am. Chem. Soc.* 76:3074-78.
- Wilmarth, W. K. and Dayton, J. C. (1953). - The mechanism of the exchange of hydrogen gas with solutions of potassium amide in liquid ammonia. *J. Am. Chem. Soc.* 75:4553-56.
- Wilmarth, W. K., Dayton, J. C. and Flournoy, J. M. (1953). - The mechanism of the exchange of hydrogen gas and aqueous alkali. *J. Am. Chem. Soc.* 75:4549-53.
- Winsel, A. (1963). - Physical and technical aspects of reducing the energy required for the electrochemical production of deuterium. *Chem. Ingr. Tech.* 35:379-85.
- Wirtz, K. and Bonhoeffer, K. F. (1936). - Liberation of protons from molecular hydrogen. *Z. Physik Chem.* 177A:1.

TABLE 1

## FEED REQUIREMENTS TO PRODUCE 100 TONNES HEAVY WATER/YEAR

| Feed Material | Deuterium Concentration in Feed | % Deuterium Recovered | Feed Volume Required  |
|---------------|---------------------------------|-----------------------|---|
| Water         | 140 ppm                         | 20%                   | 0.10 m <sup>3</sup> /s<br>(1,350 Imp. gal/min)                  |
| Synthesis gas | 130 ppm                         | 80%                   | 17 kg NH <sub>3</sub> /s<br>(1,500 tonnes NH <sub>3</sub> /day) |
| Hydrogen      | 130 ppm                         | 80%                   | 34 m <sup>3</sup> /s (STP)<br>(72,000 ft <sup>3</sup> /min)     |

TABLE 2

## HEAVY WATER PRODUCTION PLANTS

| Process                                      | Location                            | Capacity (tonnes/year) | Start-up  | Reference                           |
|--|-------------------------------------|------------------------|-----------|-------------------------------------|
| H <sub>2</sub> /steam exchange               | Rjukan and Glam Fjord, Norway       | 20                     | producing | Becker (1962)                       |
| H <sub>2</sub> distillation and electrolysis | Nangal, India                       | 14                     | "         | Becker (1962)                       |
| NH <sub>3</sub> /H <sub>2</sub> exchange     | Mazingarbe, France                  | 25                     | "         | Ellwood (1968)                      |
|  | India                               | 65                     | 1972      | Prakash - BARC private comm. (1969) |
| H <sub>2</sub> S/H <sub>2</sub> O exchange   | Savannah River U.S.A.               | 160                    | producing | Bebington and Thayer (1959)         |
|  | Port Hawkesbury Nova Scotia, Canada | 380                    | 1970      | Law (1968)                          |
|  | Glace Bay, Nova Scotia, Canada      | 360                    | 1972      | Nuclear Canada (1969a)              |
|  | Bruce Point Ontario, Canada         | 720                    | 1972      | Nuclear Canada (1969b)              |
|  | Rajasthan, India                    | 100                    | 1972      | Nuclear Canada (1968)               |

TABLE 3

## OVERALL SEPARATION FACTORS FOR DUAL TEMPERATURE EXCHANGE

| Exchange Reaction  | Cold Tower |          | Hot Tower |          | $\frac{\alpha_{\text{cold}}}{\alpha_{\text{hot}}}$ |
|--|------------|----------|-----------|----------|--|
|  | T°C        | $\alpha$ | T°C       | $\alpha$ |  |
| HD(g) + H <sub>2</sub> O(l) = HDO(l) + H <sub>2</sub> (g)  | 20         | 4.11     | 200       | 2.01     | 2.04   |
| HD(g) + NH <sub>3</sub> (l) = NH <sub>2</sub> D(l) + H <sub>2</sub> (g)                                  | -40        | 5.79     | 70        | 2.85     | 2.03   |
| DI(g) + H <sub>2</sub> O(l) = HDO(l) + HI(g)   | 10         | 4.18     | 150       | 2.42     | 1.73   |
| DBr(g) + H <sub>2</sub> O(l) = HDO(l) + HBr(g)   | 10         | 3.32     | 150       | 2.08     | 1.60   |
| DCl(g) + H <sub>2</sub> O(l) = HDO(l) + HCl(g)   | 10         | 2.72     | 150       | 1.82     | 1.49   |
| PH <sub>2</sub> D(g) + H <sub>2</sub> O(l) = HDO(l) + PH <sub>3</sub> (g)                                | 10         | 2.57     | 150       | 1.88     | 1.37   |
| HDS(g) + H <sub>2</sub> O(l) = HDO(l) + H <sub>2</sub> S(g)  | 30         | 2.22     | 130       | 1.76     | 1.26   |
| C <sub>3</sub> H <sub>7</sub> SD(l) + H <sub>2</sub> O(l) = HDO(l) + C <sub>3</sub> H <sub>7</sub> SH(l) | 10         | 2.10     | 90        | 1.77     | 1.19   |

TABLE 4

TEMPERATURES OF HYDRATE FORMATION  
AND LIQUEFACTION FOR HYDROGEN SULPHIDE

(Bebbington et al. 1959)

| Pressure          |      | Temperature °C    |                               |
|-------------------|------|-------------------|-------------------------------|
| MN/m <sup>2</sup> | psia | Hydrate formation | H <sub>2</sub> S liquefaction |
| 0.10              | 15   | 1.1               |                               |
| 0.34              | 50   | 12.2              |                               |
| 0.69              | 100  | 18.6              |                               |
| 1.38              | 200  | 25.0              |                               |
| 2.07              | 300  | 28.9              |                               |
| 2.24              | 325  | 29.5              | 29.5                          |
| 2.76              | 400  |                   | 38.6                          |
| 4.13              | 600  |                   | 56.1                          |

TABLE 5

## COSTS OF HEAVY WATER PRODUCTION (GS PROCESS)

| Capacity Basis   | Savannah River<br>450 tonnes/year<br>\$US - 1952 | Proctor-Thayer (1962)<br>180 tonnes/year<br>\$US - 1960 |
|--|--|---|
| <u>OPERATING COSTS (US DOLLARS/kg D<sub>2</sub>O)</u>                  |  |   |
| <u>MATERIALS</u>   |  |   |
| Feedwater  | 0.88   | 1.21  |
| H <sub>2</sub> S make-up   | <u>0.66</u>                                      | <u>0.11</u>   |
| Total materials  | \$ 1.54  | \$ 1.32   |
| <u>SALARIES AND LABOUR</u>   |  |   |
|  | 2.86   | 2.20  |
| <u>MAINTENANCE</u>   |  |   |
| Labour   | 2.93   | 2.86  |
| Materials  | <u>1.14</u>                                      | <u>0.55</u>   |
| Total maintenance  | \$ 4.07  | \$ 3.41   |
| <u>UTILITIES</u>   |  |   |
| Steam or natural gas   | 9.57   | 4.07  |
| Electric power   | 2.97   | 1.87  |
| Cooling water  | <u>0.44</u>                                      | <u>0.33</u>   |
| Total utilities  | \$12.98  | \$ 6.27   |
| <u>MISCELLANEOUS</u>   |  |   |
|  | 0.33   | 0.33  |
| <u>ADMINISTRATIVE AND GENERAL EXPENSE</u>                              |  |   |
|  | <u>7.92</u>                                      | <u>3.85</u>   |
| <u>TOTAL OPERATING COST</u>  | <u>\$39.70</u>                                   | <u>\$17.38</u>  |
| <u>CAPITAL CHARGES AT 14% PER ANNUM (US DOLLARS/kg D<sub>2</sub>O)</u> |  |   |
| <u>GS Process</u>  |  |   |
| Piping   | 11.44  | 3.63  |
| Towers   | 8.91   | 4.18  |
| Heat exchangers  | 4.29   | 4.29  |
| Structures   | 3.41   | 0.44  |
| Instrumentation  | 1.87   | 1.21  |
| Other  | <u>3.96</u>                                      | <u>2.20</u>   |
| Total GS process   | \$33.88  | \$15.95   |
| Distillation plant   | 0.77   | 1.21  |
| Electrolytic plant   | 0.45   | -   |
| Steam and electric power plant   | 4.62   | 0.66  |
| Water treatment and distribution                                       | 2.20   | 0.77  |
| H <sub>2</sub> S inventory   | 0.33   | 0.22  |
| General facilities   | <u>2.42</u>                                      | <u>1.98</u>   |
| Total capital charge at 14%  | <u>\$44.67</u>                                   | <u>\$20.79</u>  |
| <u>TOTAL PRODUCTION COST/kg D<sub>2</sub>O</u>                         |  |   |
| Operating cost + capital charges at 14%                                | \$74.37  | \$38.17   |
| Operating cost + capital charges at 10%                                | \$61.60  | \$32.34   |

TABLE 6

MURPHREE PLATE EFFICIENCIES FOR NH<sub>3</sub>/H<sub>2</sub> EXCHANGE

(Lefrancois et al. 1962)

| Conditions  | NH <sub>2</sub> K | NH <sub>2</sub> Rb | NH <sub>2</sub> Cs |
|---|-------------------|--------------------|--------------------|
| (a) pressure 36.8 MN/m <sup>2</sup> (375 atm.)<br>amide concentration 0.18 moles/litre<br>temperature -50°C | 4.5%              | 24%                | 22%                |
| (b) pressure 49.1 MN/m <sup>2</sup> (500 atm.)<br>amide concentration 0.68 moles/litre<br>temperature -65°C | 1.8%              | 17%                | 18%                |

TABLE 7

COMPARISON OF COSTS FOR GS AND NH<sub>3</sub>/H<sub>2</sub> PLANTS

|  | GS plant                  | NH <sub>3</sub> /H <sub>2</sub> plant |
|--|---------------------------|---------------------------------------|
| Capacity                                     | 180 tonnes/year           | 100 tonnes/year                       |
| Reference                                    | Proctor and Thayer (1962) | Becker et al. (1969)                  |
| Exchange rate                                | 1.11 \$US/\$A             | 4.09 DM/\$A                           |
| Dollars                                      | \$A 1960                  | \$A 1968                              |
| Capital cost                                 | \$A24.1 million           | \$A13 million                         |
| <u>Production cost per kg D<sub>2</sub>O</u> |                           |                                       |
| Capital charge (14%)                         | 18.70                     | 18.10                                 |
| Steam at 55 cents/tonne                      | 6.05                      | 1.20                                  |
| Power at 4 mills/kWh                         | 0.93                      | 2.24                                  |
| Labour                                       | 4.55                      | 1.46                                  |
| Materials                                    | 1.68                      | 3.18                                  |
| Cooling water                                | 0.30                      | 1.22                                  |
| Overheads and finishing                      | 3.76                      | 1.96                                  |
|  | <u>\$A35.97</u>           | <u>\$A29.36</u>                       |

TABLE 8

## BREAKDOWN OF COSTS FOR 360 TONNES/YEAR HEAVY WATER PLANTS -

WATER-BASED NH<sub>3</sub>/H<sub>2</sub> DUAL TEMPERATURE EXCHANGE

(Bancroft 1968)

| Plant Costs   | %            |                                     |
|---|--------------|-------------------------------------|
| Water treatment                                     | 4.7          |                                     |
| Hydrogen-water exchange                             | 33.3         |                                     |
| Catalyst preparation                                | 1.9          |                                     |
| Hydrogen plant                                      | 1.3          |                                     |
| Ammonia-hydrogen exchange - 1st stage               | 44.5         |                                     |
| - 2nd stage   | 4.7          |                                     |
| Final purification                                  | 2.6          |                                     |
| Utilities   | 7.0          |                                     |
|   | <u>100.0</u> |                                     |
| <u>Operating Costs - Comparison with GS Process</u> |              |                                     |
| <u>Basis GS process 100%</u>                        |              |                                     |
|   | <u>GS</u>    | <u>NH<sub>3</sub>/H<sub>2</sub></u> |
| Utilities   |              |                                     |
| Steam   | 41.6         | 16.7                                |
| Electricity   | 8.5          | 5.2                                 |
| Fuel gas  | -            | 1.8                                 |
| Materials   | 5.6          | 7.1                                 |
| Direct labour                                       | 6.2          | 6.2                                 |
| Overhead and administration                         | 5.0          | 5.0                                 |
| Maintenance   | 23.6         | 17.1                                |
| Taxes and insurance                                 | 9.5          | 11.5                                |
|   | <u>100.0</u> | <u>70.6</u>                         |

TABLE 9

## PROPERTIES OF ALIPHATIC AMINES

(Lange 1956, Delmas 1968, Rochard 1969)

| Amine         | Melting pt. °C | Normal Boiling Pt. °C | Critical Properties |                     | Hydrogen Solubility gram atom/cm <sup>3</sup> /atm. x 10 <sup>-6</sup> (-60°C) | Exchange Rate Constant k(min <sup>-1</sup> )* |
|---------------|----------------|-----------------------|---------------------|---------------------|--|---|
|               |                |                       | T <sub>c</sub> °C   | P <sub>c</sub> atm. |  |   |
| Ammonia       | -77            | -33                   | 132                 | 111                 | 1.1  | 2.2   |
| Methylamine   | -93            | -7                    | 157                 | 74                  | 3.8  | 56  |
| Dimethylamine | -96            | 7                     | 165                 | 52                  | 6.2  | 115   |
| Ethylamine    | -80            | 17                    | 183                 | 56                  |  |   |
| Diethylamine  | -50            | 56                    | 223                 | 37                  |  |   |
| n-Propylamine | -83            | 50                    | 234                 | 47                  |  |   |
| i-Propylamine | -101           | 34                    |                     |                     | 4.4  | 4.6   |

\* k is the rate constant based on the concentration of dissolved hydrogen at a temperature of -60°C and an amide catalyst concentration of 10<sup>-2</sup> moles/litre

TABLE 10

## RATE OF HYDROGEN - WATER EXCHANGE WITH VARIOUS CATALYSTS

Hydrogen pressure 1 atm. 1 litre of solution

with 0.01 mole of catalyst in all cases

(Schindewolf 1963)

| Catalyst                   | Temperature | Rate (mole/litre.sec)  | Activation Energy kcal/mole |
|----------------------------|-------------|------------------------|-----------------------------|
| Ru-chloride in 4 M HCl     | 85°C        | 8 x 10 <sup>-6</sup>   | 23.8                        |
| Co-cyanide in 0.5 M KCN    | 30°C        | 9 x 10 <sup>-8</sup>   | 7                           |
| Sodium hydroxide in water  | 115°C       | 1.5 x 10 <sup>-7</sup> | 24                          |
| Potassium amide in ammonia | -53°C       | ~ 2 x 10 <sup>-5</sup> | ~ 10                        |
| Pt on charcoal in water    | 30°C        | 1 x 10 <sup>-4</sup>   | 5.8                         |

TABLE 11

## PROPERTIES OF METHANE, ETHANE, AMMONIA AND WATER

|                               | α for H <sub>2</sub> Exchange (25°C)<br>(Varshavskii and Vaisberg 1955) | Normal Boiling Point °C | Critical Properties |                |
|-------------------------------|---|-------------------------|---------------------|----------------|
|                               |   |                         | T <sub>c</sub>      | P <sub>c</sub> |
| CH <sub>4</sub>               | 3.04  | -183                    | -83°C               | 46 atm.        |
| C <sub>2</sub> H <sub>6</sub> | 3.20  | -89                     | 32°C                | 49 atm.        |
| NH <sub>3</sub>               | 3.30  | -78                     | 133°C               | 111 atm.       |
| H <sub>2</sub> O              | 3.28  | 100                     | 374°C               | 218 atm.       |



TABLE 12

## COMPARISON OF CHEMICAL EXCHANGE PROCESSES FOR HEAVY WATER PRODUCTION

|   | H <sub>2</sub> S/H <sub>2</sub> O |                  | NH <sub>3</sub> /H <sub>2</sub> |                              | H <sub>2</sub> O/H <sub>2</sub> |                              |
|---|-----------------------------------|------------------|---------------------------------|------------------------------|---------------------------------|------------------------------|
|   | Bithermal                         |                  | Bithermal                       |                              | Monothermal                     |                              |
| Deuterium source                            | water                             |                  | synthesis gas                   |                              | synthesis gas                   |                              |
| Recovery                                    | 21%                               | 80%              | 85%                             |                              | 51%                             |                              |
| Typical Operating Conditions                |                                   |                  |                                 |                              |                                 |                              |
| Pressure atm.                               | 20                                | 200              | 200                             | 200                          | 200                             | 200                          |
| Cold tower temperature °C                   | 30°C                              | -40°C            | -40°C                           | 30°C                         | 30°C                            | 30°C                         |
| Hot tower temperature °C                    | 130°C                             | 70°C             | -                               | 200°C                        | 200°C                           | 200°C                        |
| Separation Factors                          |                                   |                  |                                 |                              |                                 |                              |
| Cold tower                                  | 2.22                              | 5.79             | 5.79                            | 4.11                         | 4.11                            | 4.11                         |
| Hot tower                                   | 1.76                              | 2.85             | -                               | 2.01                         | 2.01                            | 2.01                         |
| overall                                     | 1.26                              | 2.03             | 5.79                            | 2.04                         | 2.04                            | 2.04                         |
| Catalyst                                    | none required                     | KNH <sub>2</sub> | KNH <sub>2</sub>                | none completely satisfactory | none completely satisfactory    | none completely satisfactory |
| Energy requirement* kWh kg D <sub>2</sub> O | 7,500                             | 3,400            | 5,300                           | 2,100                        | 2,100                           | 2,100                        |

\* Energy requirement is the total heat load which must be supplied to provide steam and power

TABLE 13

## APPROXIMATE SEPARATION FACTORS FOR DISTILLATION

(Benedict and Pigford 1957, Lange 1956)

| Substance | Latent Heat at Normal Boiling Point Cal/mole Hydrogen | Normal Boiling Point |        | Triple Point |          |        |
|-----------|---|----------------------|--------|--------------|----------|--------|
|           |   | $\alpha$             | T      | $\alpha$     | P (mmHg) | T      |
| Hydrogen  | 216   | 1.81                 | -253°C | 3.60         | 54       | -260°C |
| Water     | 9,700   | 1.026                | 100°C  | 1.12         | 4.6      | 0°C    |
| Ammonia   | 3,720   | 1.036                | -34°C  | 1.08         | 45.6     | -78°C  |
| Methane   | 980   | 0.997                | -162°C | 1.0016       | 87.5     | -183°C |

TABLE 14

## COMPARISON OF SULZER PACKED COLUMN WITH SIEVE-PLATE COLUMN AT SAVANNAH RIVER

(Huber 1960)

|   | Savannah River Column | Sulzer Packed Column |
|---|-----------------------|----------------------|
| Head pressure                                   | 100 mmHg              | 100 mmHg             |
| Boil-up rate g cm <sup>-2</sup> h <sup>-1</sup> | 120                   | 100                  |
| Number of theoretical plates per metre          | 3                     | 50                   |
| Pressure drop per plate                         | 2.8 mmHg              | 0.4 mmHg             |
| Hold-up per cm <sup>2</sup> plate               | 4.8 cm <sup>3</sup>   | 0.34 cm <sup>3</sup> |

TABLE 15

## ECONOMICS OF AMMONIA DISTILLATION

|  | Drews (1955)       |                 |                            | Gami et al. (1958)            |
|--|--------------------|-----------------|----------------------------|-------------------------------|
|  | Feed Equilibration | Parasitic Plant | Parasitic Plant Optimistic | Parasitic Plant 9 tonnes/year |
| Investment \$US/kg D <sub>2</sub> O year | 400                | 320             | 275                        | 337                           |
| Production cost \$US/kg D <sub>2</sub> O | 138                | 90              | 66                         | 81                            |

TABLE 16

VAPOUR PRESSURES OF METHANES ABOVE ONE ATMOSPHERE

| T<br>°K | (Armstrong et al. 1955)<br>Vapour Pressure<br>$P_{CH_4}$ (atm.) | Grigor and Steel (1968)                                     |                     | Pogorski (1968)  |                      |
|---------|---|---|---------------------|--|----------------------|
|         |   | Vapour Pressure<br>Difference<br>$P_{CD_4} - P_{CH_4}$ atm. | $P_{CD_4}/P_{CH_4}$ | Vapour Pressure<br>Difference<br>$P_{CH_3D} - P_{CH_4}$ atm. | $P_{CH_3D}/P_{CH_4}$ |
| 120     | 1.90  | 0.06  | 1.031               |  |                      |
| 130     | 3.67  | 0.14  | 1.038               |  |                      |
| 140     | 6.38  | 0.18  | 1.028               | 1.43   | 1.22                 |
| 150     | 10.5  | 0.34  | 1.034               | 1.77   | 1.17                 |
| 160     | 15.7  | 0.59  | 1.037               | 2.04   | 1.13                 |
| 170     | 23.1  | 0.88  | 1.038               | 2.18   | 1.11                 |
| 180     | 32.4  | 1.14  | 1.035               | 1.77   | 1.05                 |
| 190     | 44.3  | 1.92  | 1.044               | 1.70   | 1.04                 |

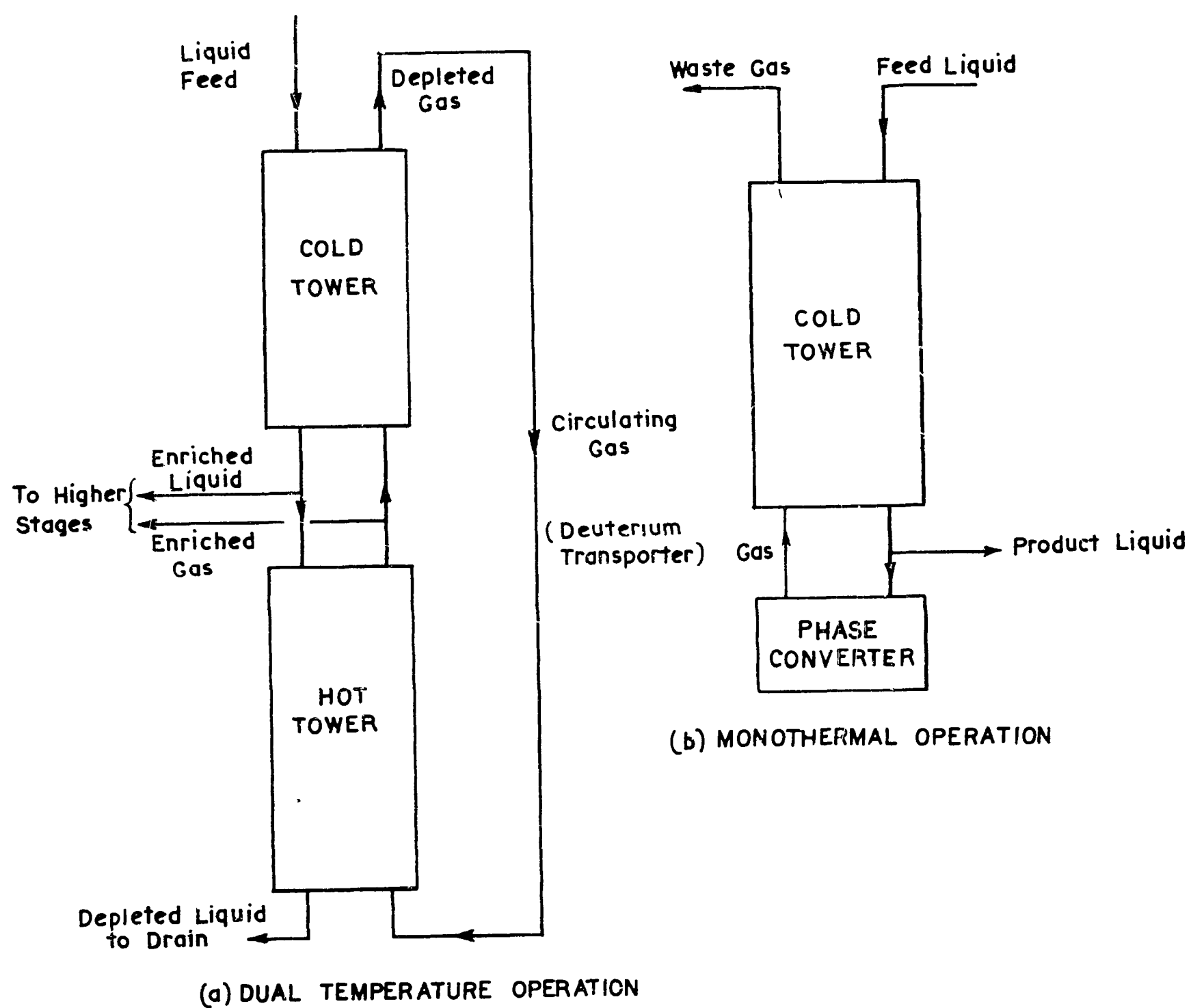

FIGURE 1. CHEMICAL EXCHANGE PROCESSES FOR HEAVY WATER PRODUCTION

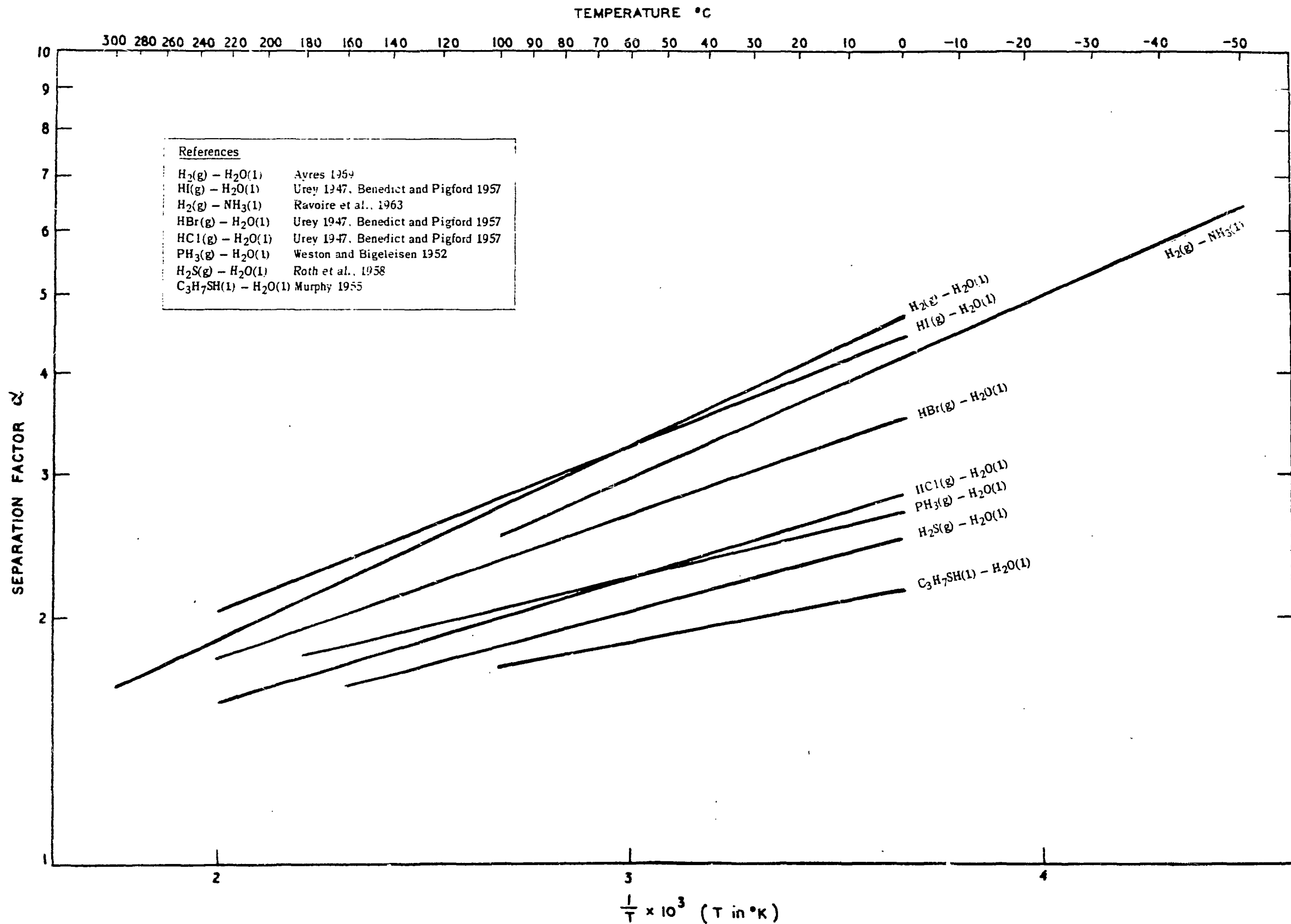

FIGURE 2. EFFECT OF TEMPERATURE ON SEPARATION FACTOR FOR CHEMICAL EXCHANGE REACTIONS

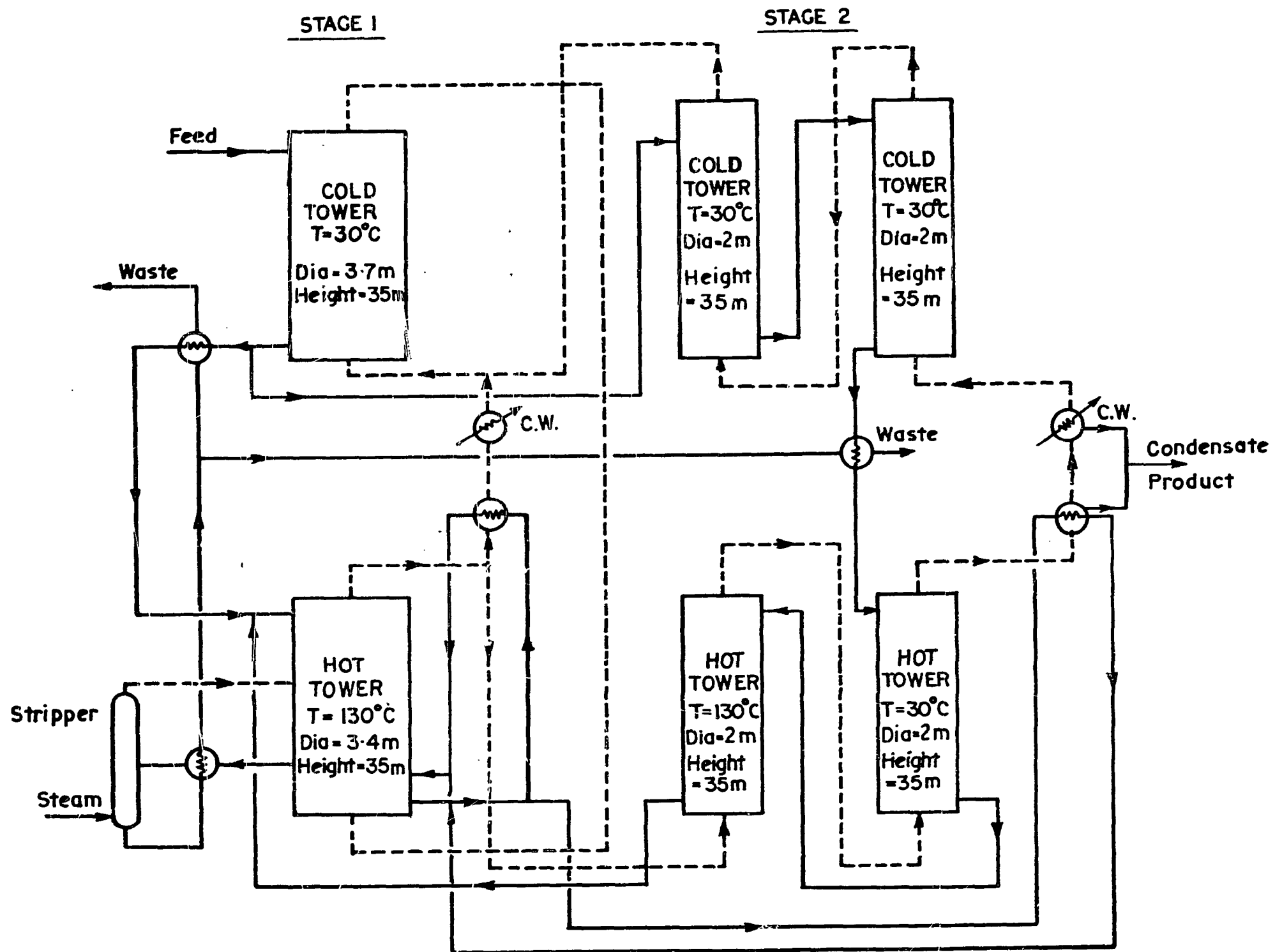

FIGURE 2 SAVANNAH RIVER CS UNIT

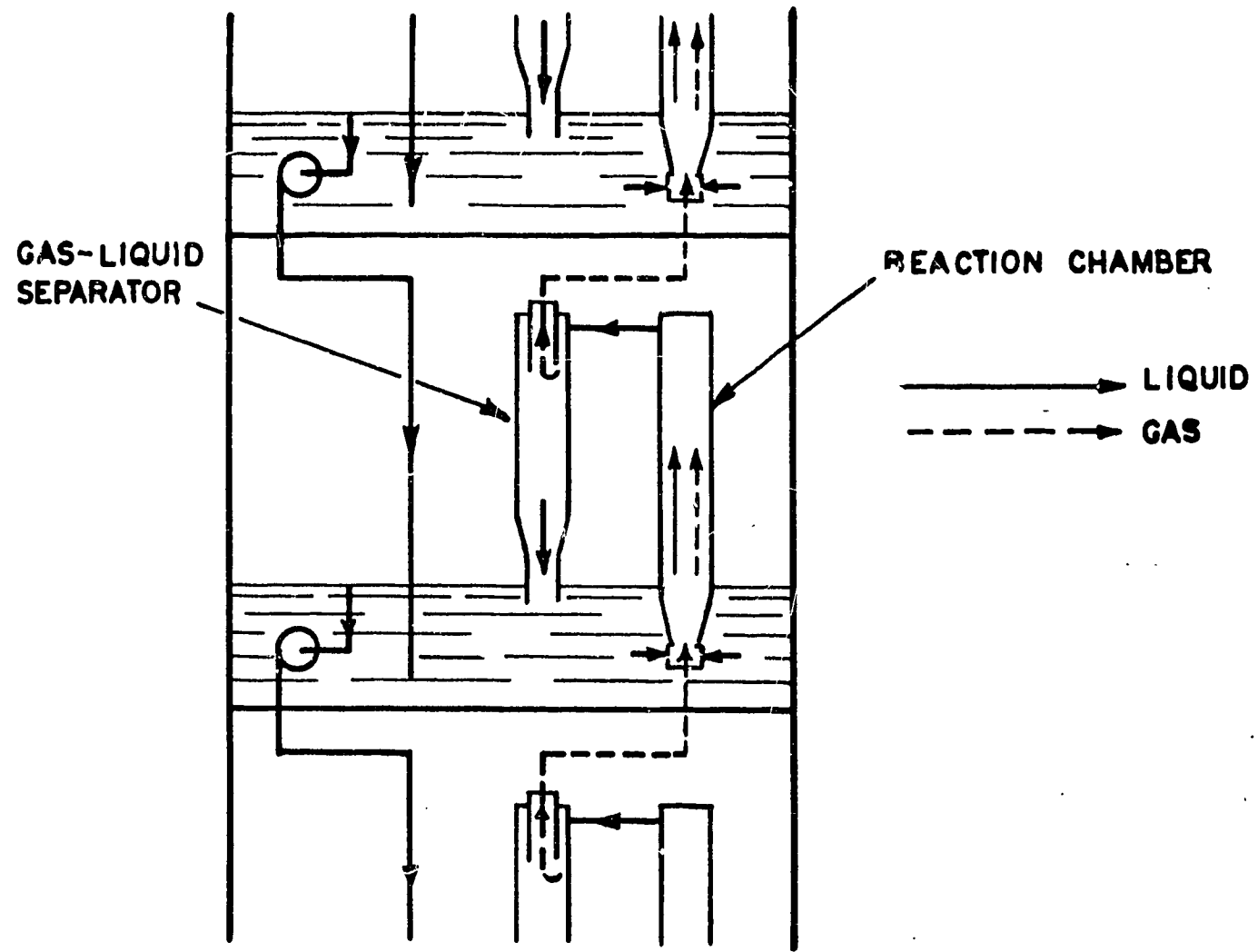

FIGURE 4. SCHEMATIC DIAGRAM OF EJECTOR ARRANGEMENT USED TO IMPROVE CONTACT EFFICIENCY (Le Chatelier 1968)

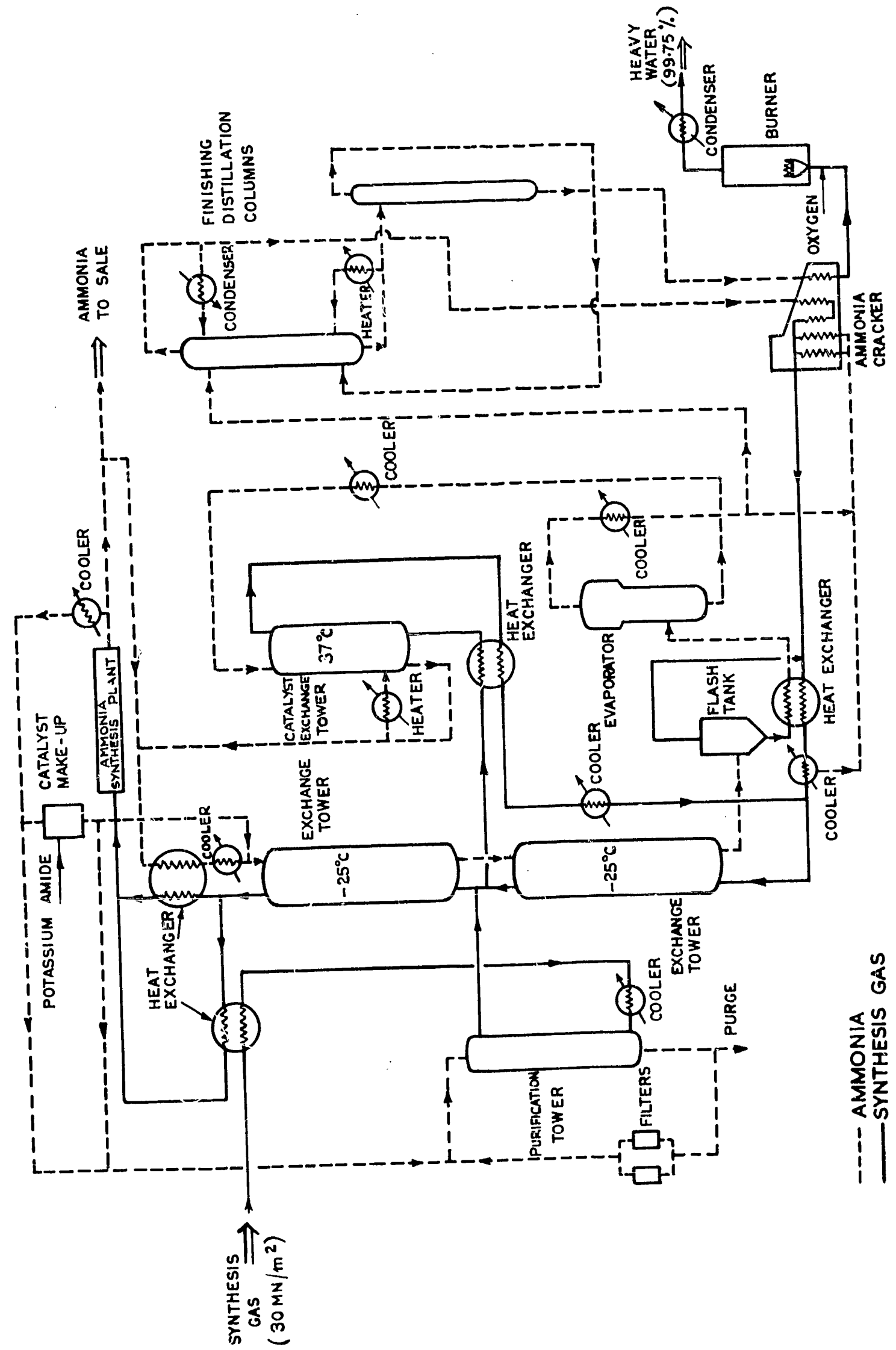

FIGURE 5. MAZINGARBE HEAVY WATER PLANT

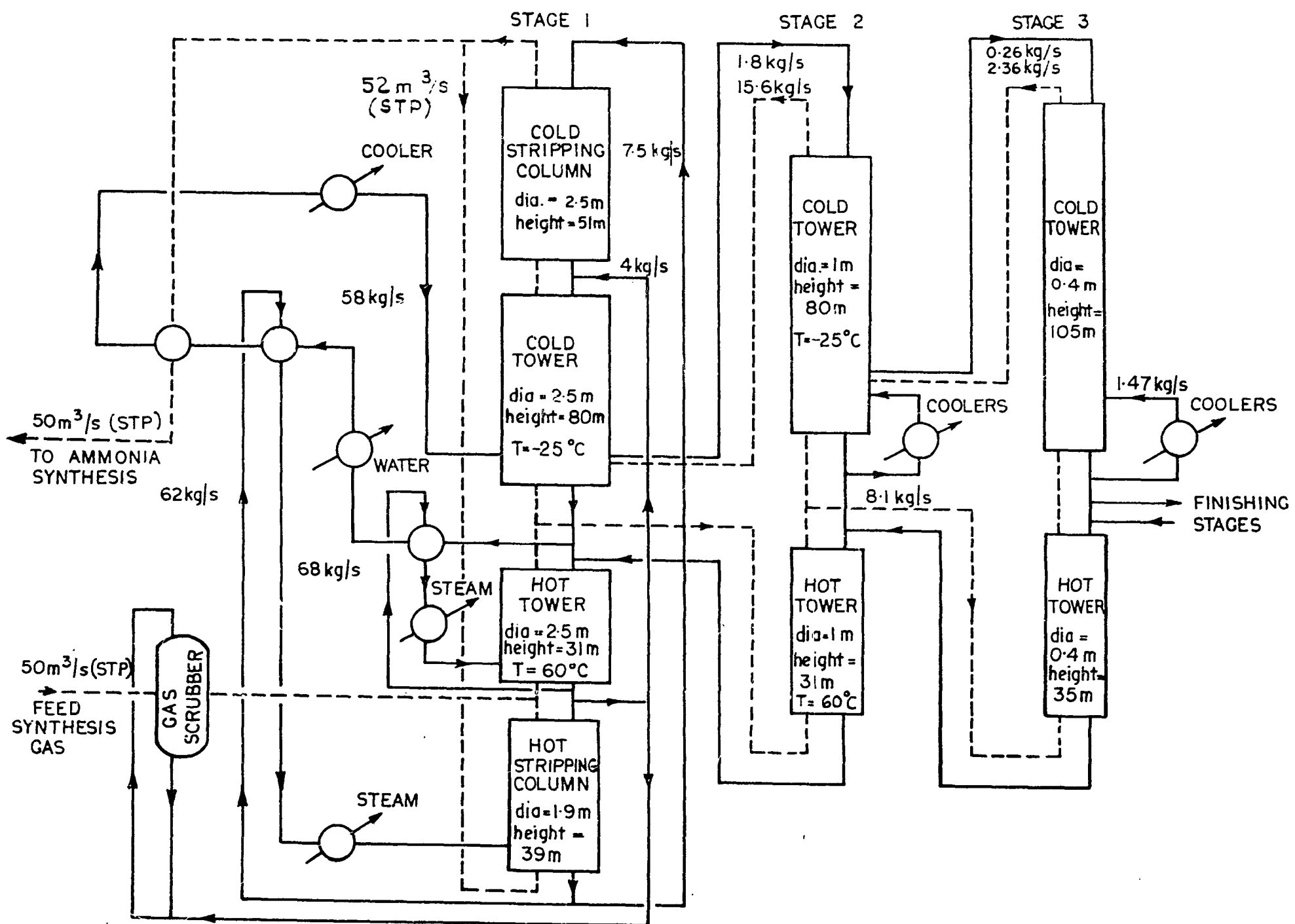

FIGURE 6. GERMAN DESIGN FOR DUAL TEMPERATURE  $\text{NH}_3/\text{H}_2$  EXCHANGE-  
CAPACITY 100 TONNES/YEAR  $\text{D}_2\text{O}$  (Becker et al 1969)

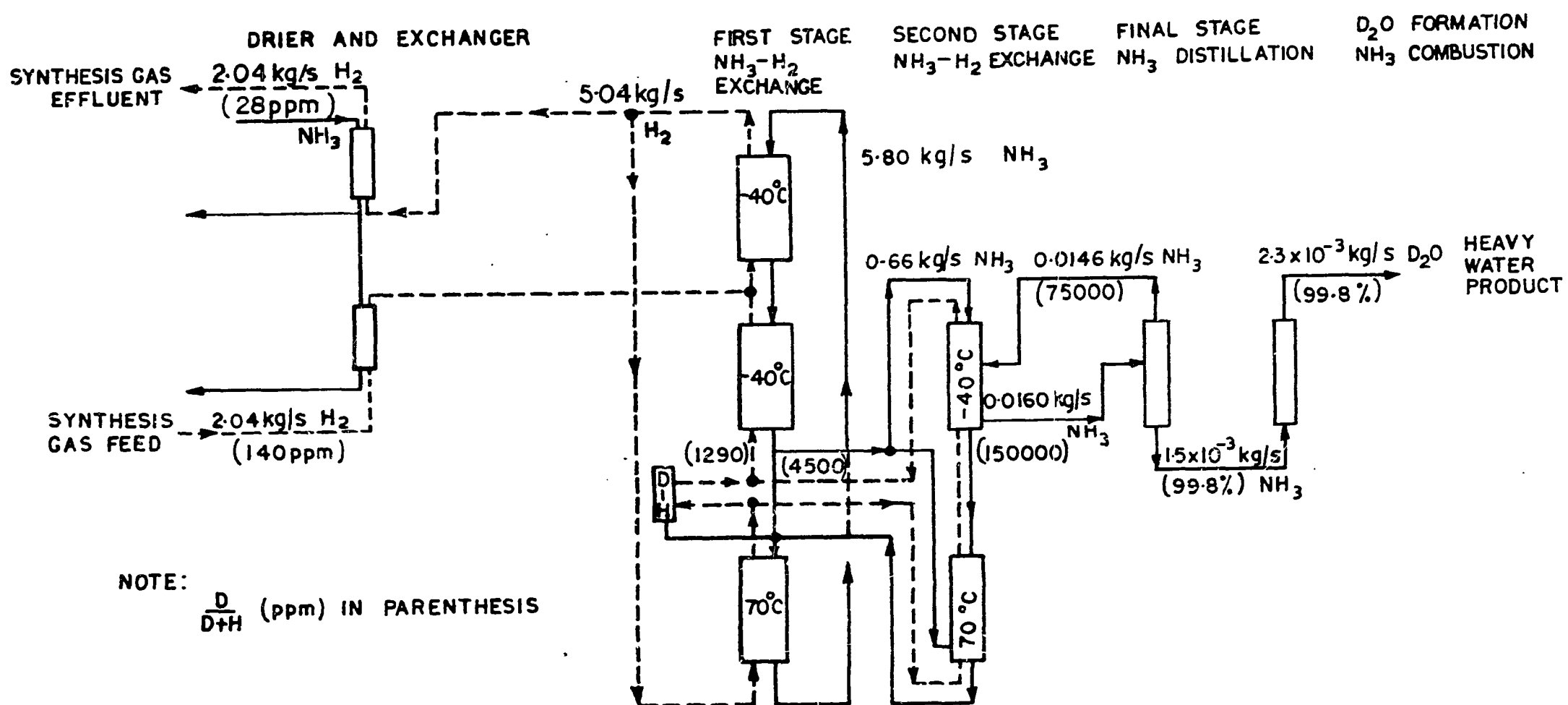

FIGURE 7. CANADIAN FLOWSHEET FOR DUAL TEMPERATURE  $\text{NH}_3/\text{H}_2$  EXCHANGE-  
SYNTHESIS GAS FEED 63 TONNES  $\text{D}_2\text{O}$ /YEAR (Bancroft 1968)



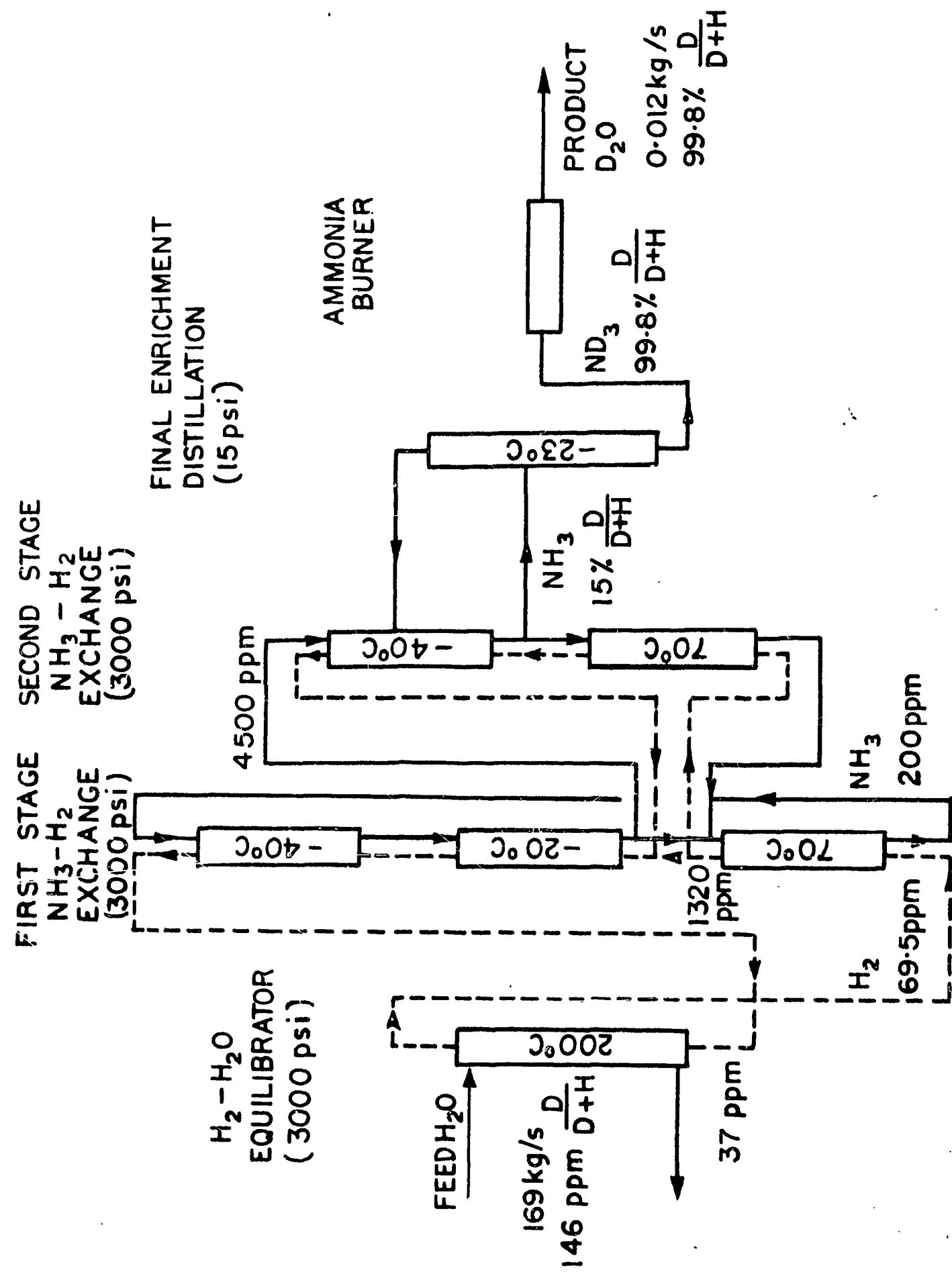

FIGURE 8. CANADIAN FLOWSHEET FOR DUAL TEMPERATURE NH<sub>3</sub> / H<sub>2</sub> EXCHANGE WITH WATER-BASED FEED EQUILIBRATION 360 TONNES/YEAR (Bancroft 1968)

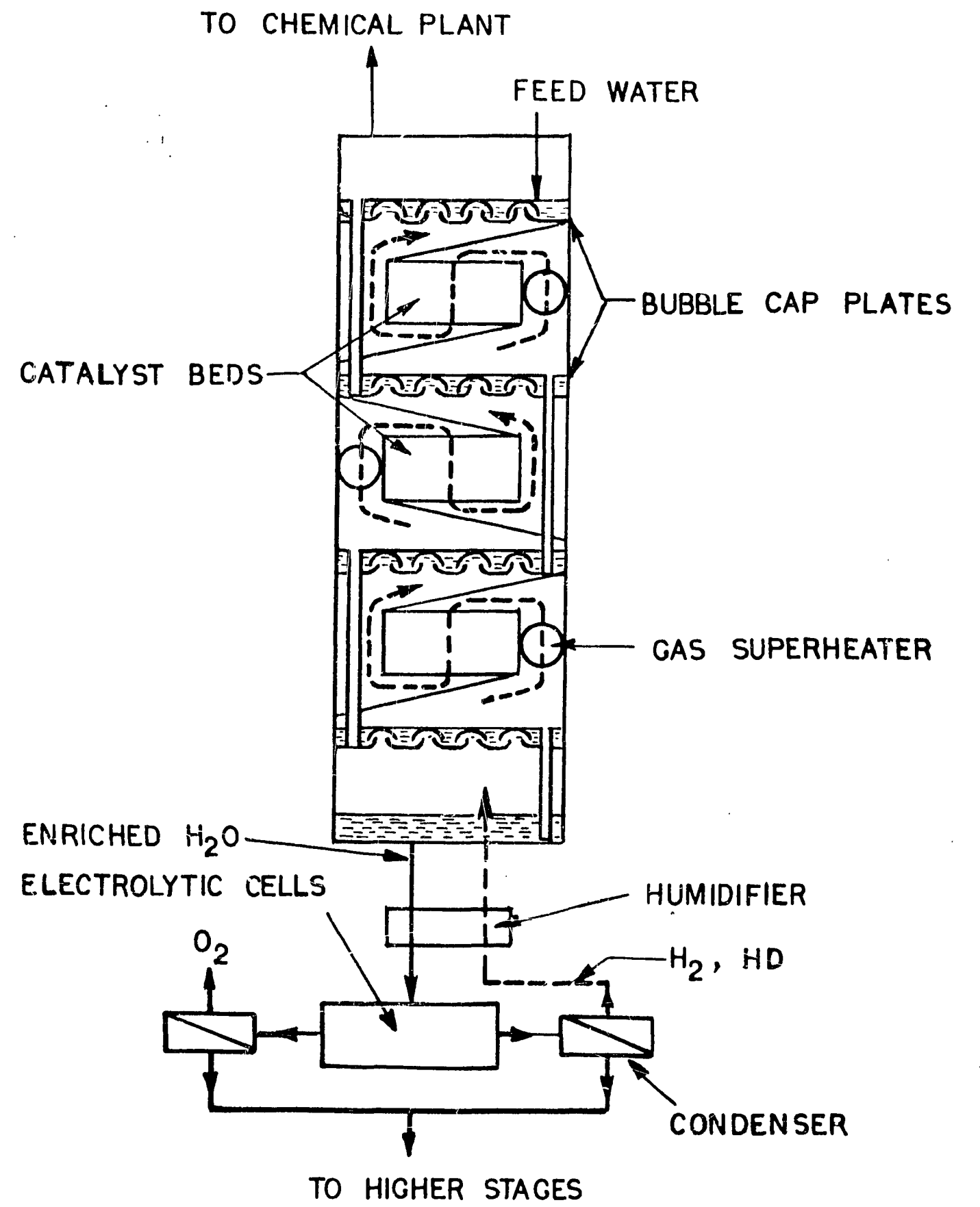

FIGURE 9. SCHEMATIC DIAGRAM OF TRAIL PLANT (Benedict and Pigford 1955, Ayres 1969)

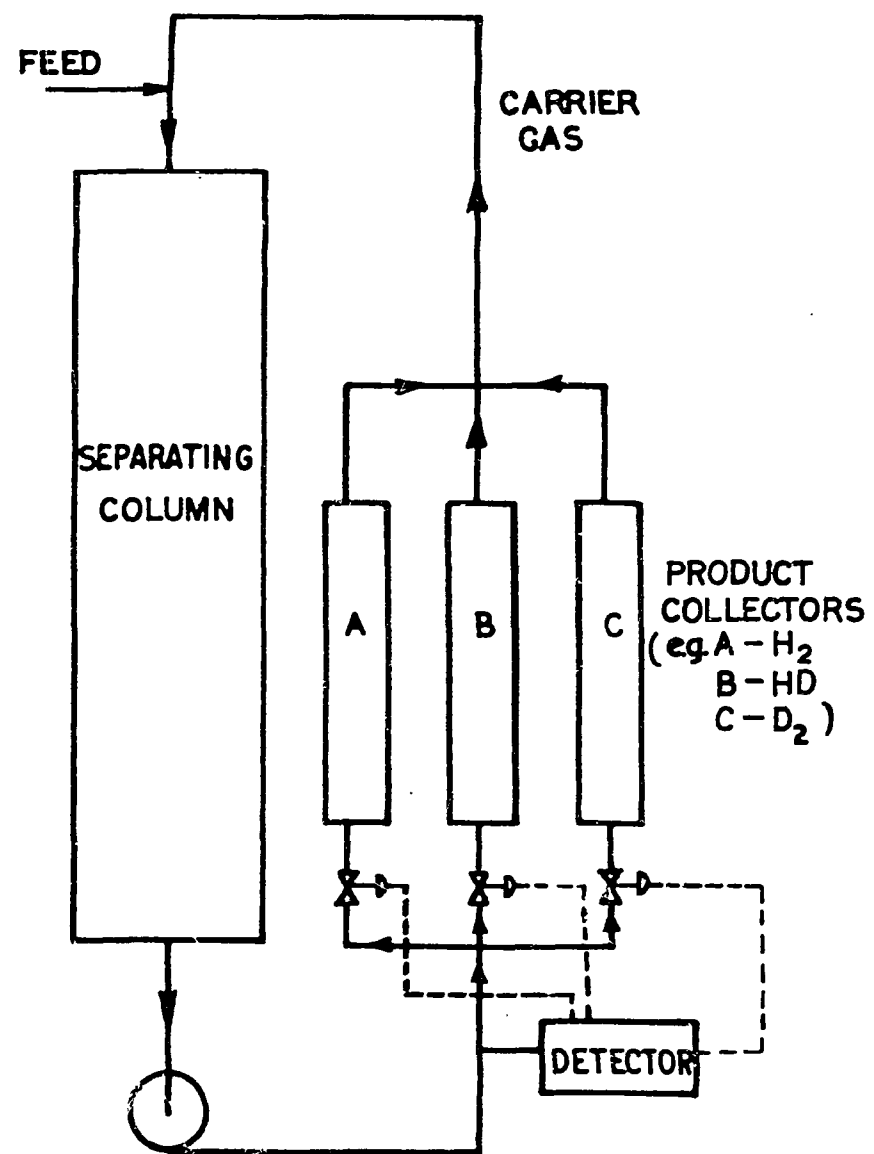

FIGURE 10A. FIXED BED CHROMATOGRAPHY  
(Timmins and Ryan 1969)

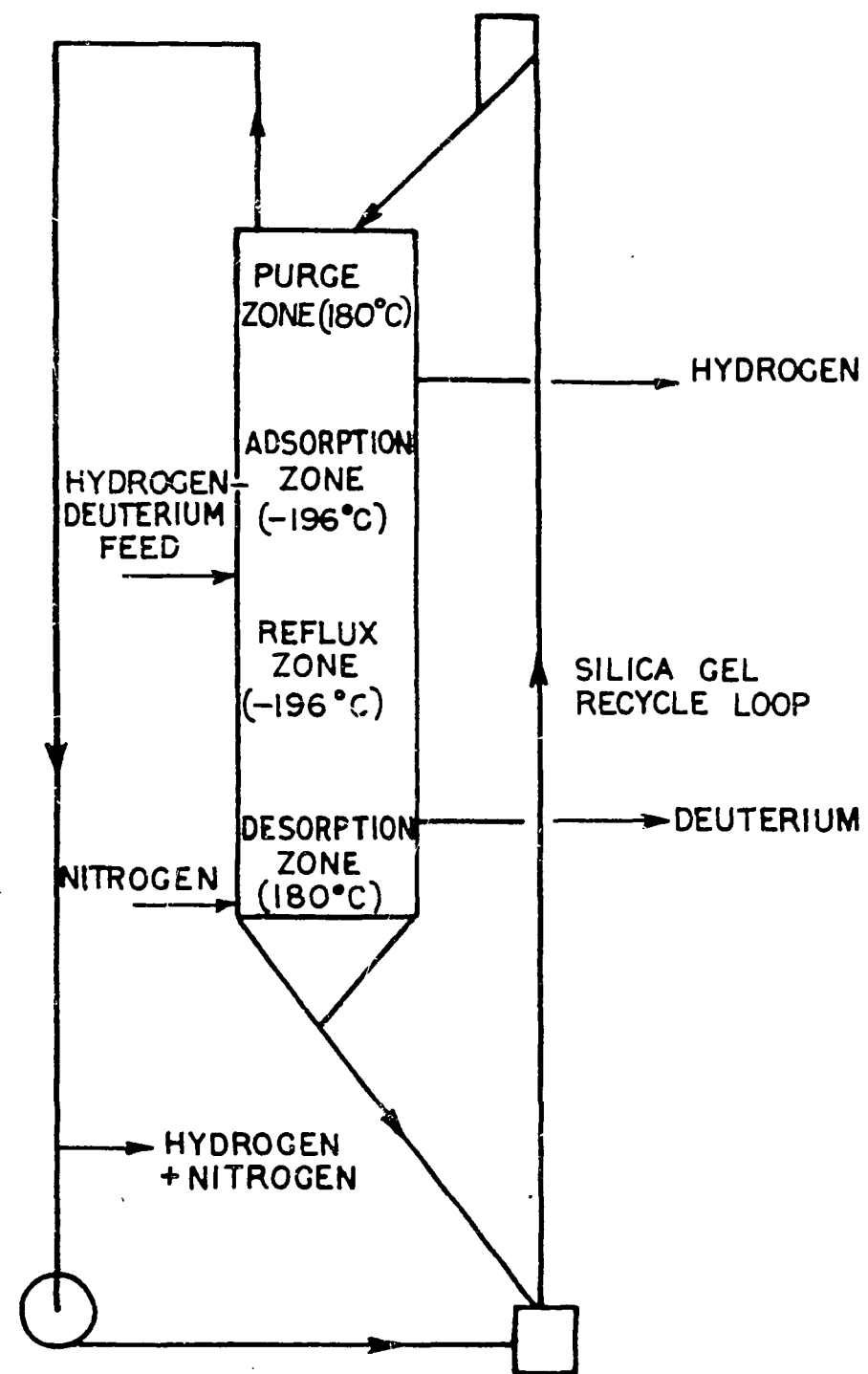

FIGURE 10B. MOVING BED CHROMATOGRAPHY  
(Clayer et al 1968)