

NOTICE

This report was prepared as an account of work sponsored by the United States Government. Neither the United States nor the United States Atomic Energy Commission, nor any of their employees, nor any of their contractors, subcontractors, or their employees, makes any warranty, express or implied, or assumes any legal liability or responsibility for the accuracy, completeness, or usefulness of any information, apparatus, product or process disclosed, or represents that its use would not infringe privately owned rights.

SUPERCONDUCTING SYNCHROTRON-STORAGE RING (ESCAR)*

R. Byrns, T. Elioff, W. Gilbert, M. Green, E. Hartwig,
G. Lambertson, K. Lou, R. Meuser, W. Pope, J. Staples,
J. Tanabe, D. Wolgast

Lawrence Berkeley Laboratory
University of California
Berkeley, California

INTRODUCTION

The ESCAR¹ (Experimental Superconducting Accelerator Ring) was conceived and authorized primarily as a development project whose main goal would be to develop design and operational experience with a complete accelerator and storage ring system utilizing superconducting magnets. ESCAR will not only provide the experience of fabricating and operating an extensive cryogenic magnet system but it will also provide a comprehensive accelerator system from which can be learned the realities of the interaction between the new cryogenic elements and the many other components of an accelerator. These components (e.g., r.f., injection, vacuum, controls, instrumentation, etc.) are now undergoing design studies and their compatibility with the cryogenic features of the accelerator is scrutinized rigorously. There is no doubt that there will be many deviations from the conventional and normal accelerator technology.

Full scale design effort began in July 1974 and operation is planned in 1977. Superconducting magnet development work at Lawrence Berkeley Laboratory has been a continuing effort in recent years; since late 1973 that effort has been expanded and directed toward the ESCAR magnet system.

The magnet system is designed for both pulsed and d.c. operation. The steady-state operation will permit experimentation with relatively high-current stored proton beams. In this area, there remain a number of issues whose resolution is vital to future storage rings. The flexibility to conduct a program of beam experiments is an important concept in the total design criteria for the various accelerator systems. Finally, the ESCAR system may prove suitable for an experimental program with high energy heavy ions or as a booster-injector for future high energy proton systems.

DESIGN GOALS AND DESCRIPTIONS

The following general parameters describe the scope of ESCAR:

Max. energy:	4.2 GeV
Intensity:	4×10^{12} p ⁺ /pulse
Pulse Rate:	6/minute
Vacuum Pressure:	10^{-11} torr
Number of Quadrupoles:	32
Number of Dipoles:	24
Dipole - Central field (max.):	4.6 T
- Effective Length:	.95 m
- Clear Aperture (radius):	7.0 cm

MASTER

The energy is chosen to permit a realistic test of high field magnets at a reasonable cost. The intensity evolves from the characteristics of the existing injector, the desire to avoid excessive apertures in the main ring magnets, and the desire to investigate high-current beam effects.

The pulse rate is determined (initially) by power supply and refrigerator capabilities. The magnet system will be capable of faster pulse rates; additional refrigeration capability can be added if higher pulse rates are desired. Of course, d.c. operation will be provided, and the low pressure expected from extensive cryogenic pumping will permit beam storage times of several hours.

PHYSICAL LOCATION

The overall layout is shown in Figure 1. ESCAR will utilize the existing 50 MeV linac which is used also as a proton injector for the Bevatron. A pulsed magnet will direct the 50 MeV beam either to ESCAR or to the Bevatron. ESCAR is located at the north of the existing Bevatron experimental hall which provides roof coverage, 30-ton crane facilities, and heavy duty floor and foundation. Adequate power and water distribution systems are located in tunnels below the experimental hall where provisions for northward extension of these services presently exist. The ESCAR and the Bevatron/Bevatron programs are expected to be compatible.

MACHINE GEOMETRY

The ring, of 15 m average radius, has 4 long straight sections, each 6 meters in length. The South straight section is occupied by the injection system with inflection from below the circulating beam. The injection transport will be .9 m below ring centerline.² The West straight section contains the normal accelerating r.f. system, and the other straight sections are available for experiments, monitoring, and diagnostics.

The magnet layout in a quadrant or cell of the lattice (Figure 2) is a separated function structure with focusing provided by the groups of four quadrupoles. Six dipoles, each ~ 1 meter long, form the 90° arc of each quadrant. This arrangement provides adequate straight sections and a loosely packed lattice structure which is desired for diagnostics and general flexibility. The lattice structure³ allows arbitrary values for the transition energy. The nominal value chosen, $\gamma_t \approx 8$, is well above the peak energy - as it would be difficult at best to cross transition with 4×10^{12} protons. The high value of γ_t has been achieved by the action of the strong Q-4 lenses that reduce the excursion of off-momentum particles in the curved regions. Independent variations of v_x , v_y , and γ_t may be obtained by adjustments of the quadrupoles. γ_t can be brought within the machine energy range if experimentation on crossing γ_t is desired.

INJECTION AND EJECTION

To obtain the intensity of 4×10^{12} protons, one must use multiturn injection and stack about 11 effective turns, of which about 90% will be captured by the accelerating r.f. The stacking will be done in vertical betatron space using four programed kicker-magnets.⁴ If needed for additional intensity and to make the beam cross-section more round, the beam from the linac may be split vertically and recombined radially before injection to reduce the vertical emittance.

For an experimental accelerator, it is particularly desirable to minimize radioactivation by the accelerated beam. Normal operation will include deceleration of the beam and controlled internal dumping at an energy below 150 MeV. The primary goal of the project and studies of single-particle dynamics can be done with reduced intensity. For emergency beam dumping at high intensity, a pulsed magnetic ejector system with bump magnets and internal copper blocks is planned to protect the cryogenic magnets.

ACCELERATING RADIOFREQUENCY SYSTEM

For the greatest flexibility in beam experiments, the particles shall be accelerated in one bunch at the first harmonic frequency. After acceleration, if desired, the beam can be more tightly bunched or divided into multipole bunches by a second, higher frequency system. It is possible that a single drift tube may serve for both frequencies: that is, it will act as an accelerating drift tube at the fundamental frequency and also act as a half-wave resonator at the 11th harmonic. For experiments with extremely short bunched beams, it will be possible to add other high frequency cavities. A preliminary design study on a drift tube concept has been completed and a single-gap cavity design is now under study.⁵

SUPERCONDUCTOR

The dipole coil uses "Rutherford" cable, made of many round composite wires with the finished cable being heavily compacted to a rectangular shape. The aspect ratio of the rectangular cable increases with the number of composite strands in the cable. A 7 wire cable with an aspect ratio of 2.3:1 (2.88 mm x 1.23 mm) has been tested and we are awaiting delivery of 18 wire cable with an aspect ratio of 5:1 (5 mm x 1 mm).

Pulsed service in ESCAR requires a cable containing NbTi filaments of 5 to 10 micron diameter and a doubling dB/dt greater than 20 kG/sec. Determinations of short-sample characteristics (greater than 50 cm sample lengths) are made at fields up to 100 kG. Hysteresis losses and rate-dependent coupling losses in the cables are measured in magnetization tests. A final test of the cable's stability in a magnet winding is made by winding the test conductor into a small (approx. 6 x 10 cm) solenoid.

A most successful conductor, produced for us by Supercon, is a flattened cable of seven wires; each wire is 0.75 mm diameter and contains 3000 filaments, each of 10 μ diameter. This cable is

flattened and compacted, without being soldered, to an aspect ratio of 2.3:1. In the solenoid test, this material reached its short-sample current (defined by 10^{-11} ohm cm resistivity) which corresponds to the exceedingly high overall current density of 35,000 A/cm² in the coil at a field of 64 kG. For ESCAR, the design current densities are 20,000 to 30,000 A/cm² at a maximum field of 55 kG.

MAGNETS AND CRYOSTATS

A preliminary design for the dipole magnets is shown in Figure 3. The coil is wound in layers. In each layer the conductors are grouped in sectors, the positions and widths of which are adjusted to minimize aberrations in the magnetic field. The number of layers required will depend on the current density and the aspect ratio of the conductor to be used. The cable is wrapped with an open spiral of epoxy-impregnated fiberglass tape, which acts as a spacer to permit permeation of the coil bundles by liquid helium. The resin is cured after each layer is wound. A cold beam tube encloses the evacuated bore and is the inner structural member that supports the coil. Spacers between the coil sectors and an outer clamp rigidly position the magnet conductors. Circular cylindrical structures are used in the coil region for their convenience in analysis and in fabrication.

Alternate design studies having the iron outside or inside the cryostat are being considered. With the iron outside, structural rings are shrink fitted onto the magnet coil, and the helium cryostat wall also gives stiffness to the coil package. With iron inside, the iron can provide the mechanical support but magnetic saturation becomes a troublesome factor in the magnet's performance. The final choice between these design alternates will be made following further study. The winding of full-size dipole coils has begun and prototype magnets are scheduled for early 1975. The quadrupoles, in comparison, have lower field at the windings and simplified coil construction.

CRYOGENIC SYSTEM

The basic helium refrigeration needs⁶ of ESCAR will be supplied by a 1500 watt (4.2°K) cold box and helium screw compressor system. The 1500 W is seen as a static load of 895 W to the magnets (including distribution), 225 W to the cryopumps and a dynamic load of 400 W.

The distribution system is divided into two series circuits each fed through its own control pot. One circuit supplies the magnets, whose cryostats are interconnected at the top in series. In effect, the two-phase helium flows with minimum pressure drop from one magnet to another in a channel over a series of weirs with the liquid completely covering the magnets. A by-pass circuit is provided to permit the warming-up of individual quadrants. The other circuit supplies the cryopumping panels in series without any by-pass circuit since the heat capacity involved is small.

VACUUM

The vacuum system will be designed for 10^{-11} Torr in the main ring. It is believed that this can be economically obtained via distributed cryopumps at 4.4°K. This is the operating temperature of the cold-bore superconducting magnets and provides practically unlimited pumping capacity for all gases except helium and hydrogen. Hydrogen can be pumped effectively by bare surface cryopumps up to a coverage of eight tenths of a monolayer. The only helium gas loads which would arise come from leaks from the refrigeration system. Helium is pumped by bare-surface cryopumps at a pressure of 10^{-11} Torr to only 1/1000 of a monolayer before saturation. Because of the large area of cold surface available, the bore is expected to provide pumping for weeks of operation before saturation from cryodeposit accumulation.

While a cold bore through most of the system provides excellent cryopumping, the surfaces surrounding a high intensity beam are a concern with respect to gas desorption, the electrical impedances presented to the beam, and the potential need for ion clearing electrodes. Consequently, various liners for the bore are being considered.⁷ These vacuum system questions are an important part of the ESCAR mission.

RESEARCH POTENTIALS

In addition to the primary goal of obtaining a workable superconducting accelerator system, it is expected that ESCAR can be effectively utilized to investigate phenomena related to high current stored proton beams. The relatively long straight sections would permit the addition of special diagnostic components, low- β insertions, or r.f. systems to accomplish strong bunching, as required, for example, in the PEP device. A number of potential beam studies for ESCAR have been suggested.⁸ ESCAR could provide also unique physics research facilities for ultra-heavy ions.

* Work supported by the U.S. Atomic Energy Commission.

REFERENCES

1. R. Avery, et al., Proceedings of the IXth International Conference on High Energy Accelerators, Stanford, Calif., May 2-7, 1974.
2. J. Staples, "ESCAR Injection Line", LBL Internal Note EDG-10.
3. This lattice was designed by A.A. Garren and involves techniques utilized by V.V. Vladimirov and E.K. Tarasov, "Problems of Cyclic Accelerators", USSR Academy of Sciences, Moscow, 1955.
4. G. Lambertson, "Injection Process and Intensity Estimate", LBL Internal Note EDG-10.
5. D. Hopkins, "ESCAR RF Acceleration Beam Storage", LBL Internal Note EDG-60.
6. M. Green, "The Cold Helium Refrigeration Distribution System for ESCAR", LBL Internal Note EDG-51.
7. R. Wolgast, "Preliminary Design of the ESCAR Vacuum System", LBL Internal Note EDG-30.
8. 1973 PEP Summer Study Report, LBL-SLAC Study Group, PEP Note #66, March, 1974.

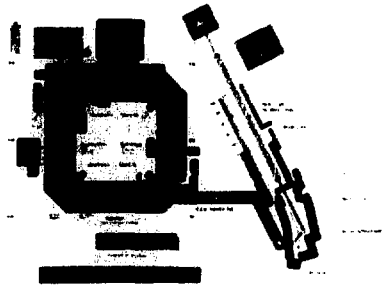

Figure 1



Radius (Circ./2 π)	R 15.29 m	Drift Lengths (Effective):	
Magnetic Radius	ρ 3.6287 m	LL	300m
Cell Length	L_c 24.0 m	O	0.20m
Quadrupole Effective Length	L_q 0.6 m	A	0.70m
Dipole Effective Length	L_d 0.85 m	L	1.56m
		S	0.43 m

Figure 2 - ESCAR Quadrant Schematic

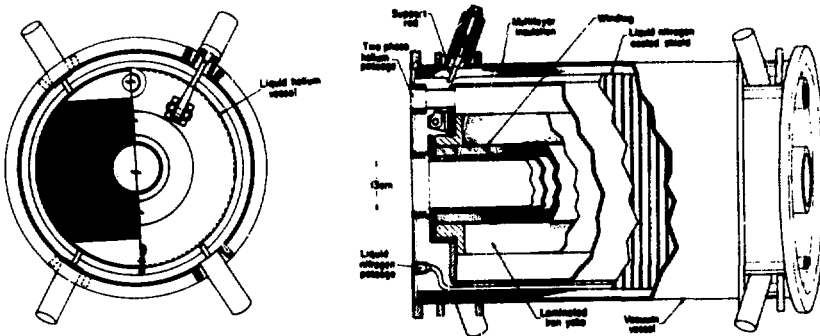

Figure 3 - Dipole magnet with iron inside cryostat (elevation)