

OPERATION OF KEK PREINJECTOR

S. Fukumoto, H. Ishimaru, K. Ito, C. Kubota, T. Sakaue, A. Takagi and S. Takano
National Laboratory for High Energy Physics
Oho, Tsukuba, Ibaraki 300-32, Japan

Abstract

High voltage apparatus of the KEK preinjector are briefly reviewed. Intensity modulation or noise of the accelerated beam was eliminated by biasing negatively the plasma cup of the duoplasmatron ion source. Ion beam of 600 mA is accelerated routinely to 750 keV with accelerating gap of 22 cm and 230 mA is injected into the proton linac. Normalized beam emittances are $0.3 \sim 0.5 \pi$ cm mrad at the entrance of the linac. Beam loading of the accelerating voltage is more than 15 kV without bouncer and it is compensated to less than 2 kV with bouncer. There is no appreciable change in the energy spread of the linac beam for $\pm 0.5\%$ of injection energies.

Introduction

In October 1971, a half year after the establishment of National Laboratory for High Energy Physics (KEK), an 800 kV Cockcroft-Walton generator was moved from the Institute of Nuclear Study, Tokyo University, to KEK at Tsukuba. On July 23, 1974, the first ion beam was accelerated to 700 keV. A design

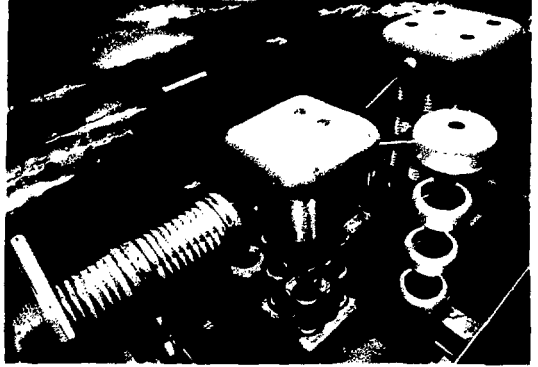

Fig.1. Bird's-eye view of KEK preinjector.

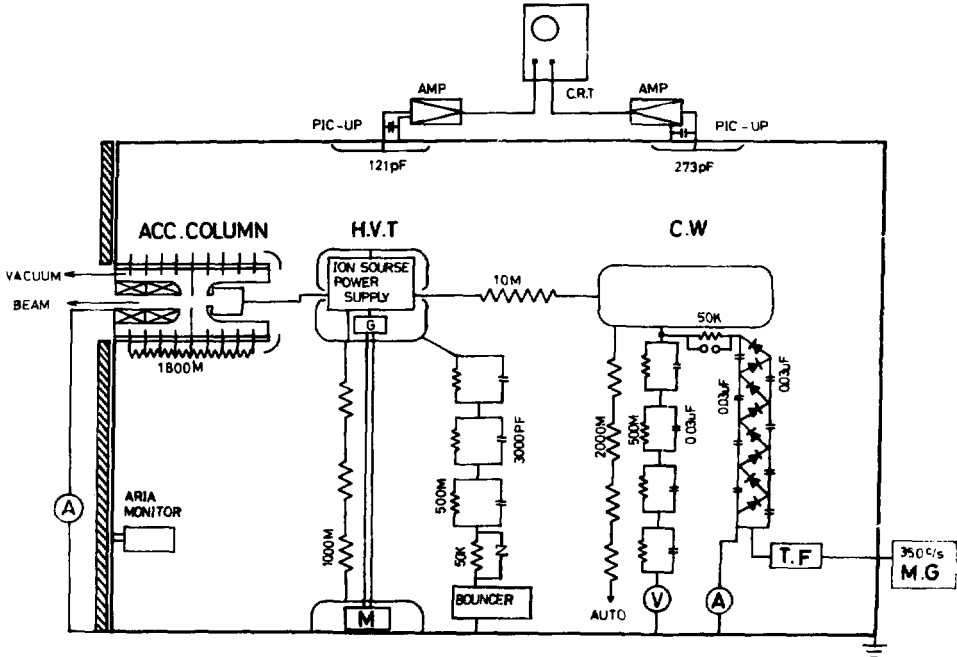

Fig.2 Schematic diagram of high voltage apparatus.

energy of 750 keV was achieved immediately with beam intensity of 100 mA on July 24. Since then, the preinjector has accelerated ions to inject them into a 20 MeV proton linac. The maximum repetition rate is 20 pps. Also efforts have been done to improve its operating characteristics.

High Voltage Apparatus

The Cockcroft-Walton generator was made in 1967. It is an open type with voltage stability of $\pm 0.2\%$ including drift and ripple. It is equipped with eight selenium rectifiers and its frequency is 350 Hz. The maximum rating of continuous current is 5 mA. It has a filtering capacitor of 0.0075 μF and a resistor of 500 $\text{k}\Omega$ to reduce ripple voltage. It may be used as an unstabilized power supply and this mode of operation is convenient for conditioning of the accelerating column. Its output voltage is fed to a high voltage terminal with a long resistor of 10 $\text{M}\Omega$.

Electric power for the ion source is supplied by a generator of 5 kVA (100 volts, 50 Hz) in the high voltage terminal. It is driven by a motor with a shaft which consists of three fiber-reinforced plastic bars of one meter long. The generator is mounted directly on the high voltage terminal, so the accelerating column is separated mechanically from the high voltage terminal to prevent vibrations caused by the generator.

Beam loading in accelerating voltage is compensated by an open loop bouncer. It is a hard tube pulse generator with the maximum rating of 50 kV for 30 μs pulse duration. Its output voltage is fed to 1000 pF capacitor with a 50 $\text{k}\Omega$ resistor, whereas the capacitor is connected directly to the high voltage terminal as shown in Fig.2. Ions are accelerated by a high gradient accelerating column which consists of two big porcelain tubes!

Duoplasmatron Ion Source

A cut-away view and a cross-sectional drawing of the duoplasmatron are shown in Fig.3. Until March 1976, a nozzle type plasma cup² was attached to it in the accelerating column with overall accelerating gap length of 31 cm. The cup is now removed and the 50 keV extracting electrode is connected to the duoplasmatron anode with an 1 $\text{k}\Omega$ resistor, so that the extractor serves as a big plasma cup³ as shown in Fig.4. The accelerated beam was intensity-modulated by noise during the first eight months of the operation. The modulation was eliminated by biasing negatively the plasma cup as shown in Fig.5. It suggests some kind of instability is generated or at least amplified in the large plasma cup⁴. The negative voltage can be supplied by auto-bias. This method is adopted for simplicity. Strictly speaking, however, the effect of the negative bias is somewhat different for individual duoplasmatron.

The cathode is replaced according to schedule, and no deterioration occurs until 800 hours. The diameter of the anode hole is 1.5 mm and the distance between the anode and the intermediate electrode is 8 mm. Arc current and voltage are 60 A and 90 volts under the hydrogen pressure of 0.25 Torr. Ion source parameters, such as arc current, cathode

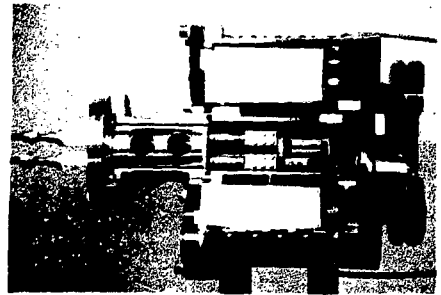

(a)

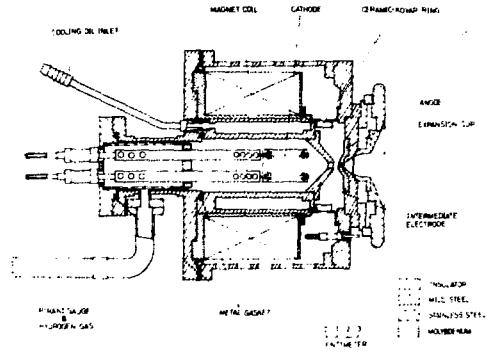

(b)

Fig.3 Duoplasmatron ion source, (a) cut-away view, and (b) cross-sectional drawing.

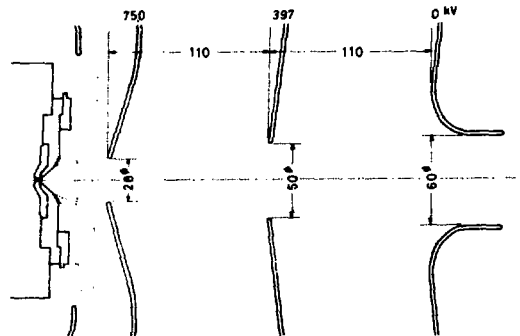

Fig.4 Schematic diagram of accelerating electrodes and duoplasmatron anode.

Operational Results

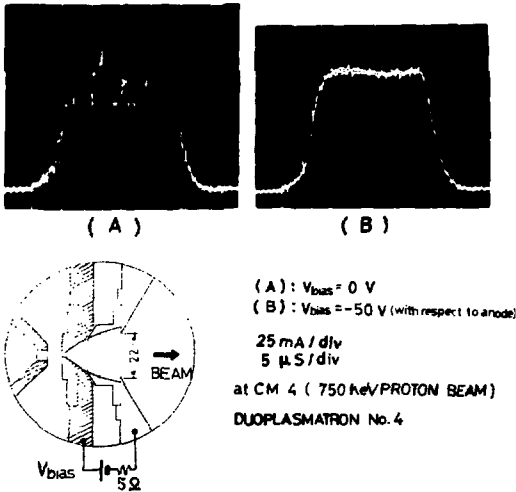

Fig.5 Negative bias eliminates noise or intensity modulation of beam.

power, magnetic field and hydrogen flow, are controlled by an infrared light telemeter system. It has a pair of light channels, from the ground to the high voltage terminal and vice versa. Triggering pulses of the arc are also transmitted by the same system. Interlock and reset signals are transmitted by another pair of simpler infrared light channels.

The aperture of a focusing quadruplet, which is immediately after the accelerating gap, is as large as 9.08 cm. Somewhat divergent beams are focused by this optical system so that the beam intensity increases.

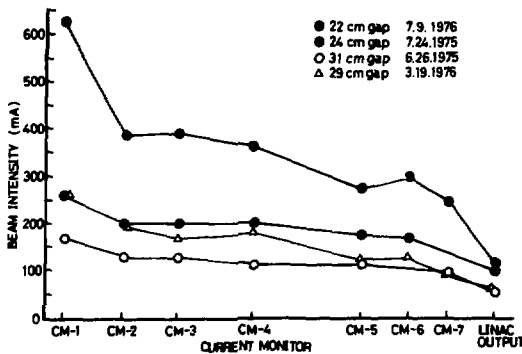

Fig.6 Beam intensities along 750 keV beam line. Intensity of the linac beam is also included.

Beam intensities are measured by seven toroid current transformers⁵ from just after the accelerating gap to the entrance of the linac. Typical examples are shown in Fig.6. The 6-th toroid, CM-6, which is just upstream of a buncher, is always affected by secondary electrons, because the beam size is somewhat larger than the aperture of the buncher. When the beam intensity was 200 mA at the CM-1 with the accelerating gap of 31 cm, the maximum beam intensity was achieved at the exit of the linac. The intensities of more than 200 mA gave lower intensities of the linac beam. And the beam became so divergent that ions impinged upon an electrode, which is denoted by 0 kV in Fig.4 and grounded with an ammeter⁶. The ammeter also indicates microdischarges before they grow into big breakdowns. Molecular ions might be mainly responsible for decrease in beam intensity at CM-1 and CM-2 for longer gap.

Beam intensities are increased from 200 mA of 31 cm gap to 600 mA of 22 cm gap by a factor of 3, whereas a ratio of the squares of the gap lengths is $(31/22)^2 = 1.99$. This discrepancy is due to the fact that more divergent beam can enter into the focusing channel for shorter gap, because the apertures of the accelerating electrodes are unchanged. Too divergent ions also might be lost in the channel between CM-1 and CM-2.

During the ion beam is accelerated, a droop of the column voltage is observed by a capacitor pick up. It is more than 15 kV without bouncer and is compensated to less than 2 kV with bouncer as shown in Fig.7. If the bouncer is turned on without beam, the column voltage is raised as shown in Fig.7. However, no breakdown takes place. Energy spread of the linac beam was measured as a function of injection energies (Fig.8). There is no appreciable change in the energy spread for injection energies of 742 keV to 754 keV. Then, 0.5 % of injection energies is tolerable. The buncher is installed 80 cm upstream from the first linac gap.

At the beginning of the operation, the system was evacuated by three 1000 U/s sputter ion pumps.

The pressure was about 1×10^{-5} Torr with beam. Although the column was carefully conditioned under the pressure of less than 1×10^{-6} Torr, frequent breakdowns took place during the operation. Then, the pressure was raised to 1×10^{-4} Torr and no breakdown occurred for 12 hours after conditioning. However, the column suffered breakdowns later and it should be conditioned again. Since the sputter ion pump does not work under the pressure of 1×10^{-4} Torr, the system is evacuated by a 650 U/s turbo molecular pump which was ordinary prepared as a rough vacuum pump. The pressure in the column was raised again to prevent breakdowns from 1×10^{-4} Torr to $2\text{-}3 \times 10^{-4}$ Torr. Little conditioning is necessary. The sparking rate becomes less than one per day. The column pressure can be adjusted by the rough vacuum of the turbo molecular pump.

During acceleration of the ion beam of 4 pps with 15 μs duration, X-ray radiation is 2 mR/hour

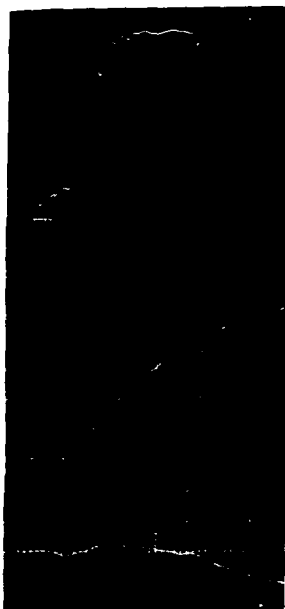

Fig.7 Beam loading compensation oscillograms. Abscissa: 5 μ s/div., ordinate: 5 kV/div.

at 5 m from the column, and it reduce to 0.05 mR/hour without beam. The X-ray radiation is nearly proportional to the average beam current.

Recently, computer controlled emittance probes came into operation.⁵ Normalized beam emittances, ϵ_{yA} , are 0.3 ~ 0.5 π cm mrad for 90 % of beam intensity at the entrance of the linac. They are consistent with the values which were measured previously by the pepper-pot method.

Total operating time from June 8 to August 7 of this year was 477.9 hours. Down time due to accelerator failure was 35.2 hours or 7.3 % of total operating time. Down time due to preinjector failure was 0.9 hours or 0.2 % of total operating time. It was caused by breakdowns in the column and failure in interlock system in the high voltage terminal.

Concluding Remarks

The KEK preinjector accelerates ions of 600 mA to 750 keV in routine operation, thus the linac beam intensity of 120 mA is achieved. Measurements with the computer controlled emittance probes are being continued to tune the ion source and the focusing magnets. If higher beam intensity is achieved, then a bouncer with fast feed back loop should be included, because the accelerating voltage will be affected by pulse-to-pulse change in beam intensities.

beam current
560 mA

with beam
without
compensation

without beam
with
compensation

with beam
with
compensation

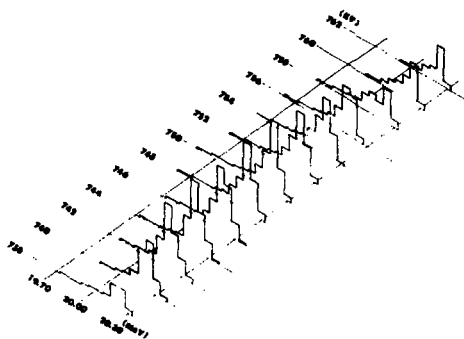

Fig.8 Injection energies vs. energy spread of linac beam.

Acknowledgment

The authors would like to express their gratitude to Dr. S. Suwa and Prof. T. Nishikawa of KEK for their interests and encouragements and Dr. Th. Sloyters of BNL for his collaboration at KEK and for his valuable comments. They are indebted to Prof. Tanaka and his crew for linac operation.

References

1. S. Fukumoto and S. Takano, KEK Preinjector Accelerating Column, Proc. this Conf.
2. M. Kobayashi, T. Nishikawa and A. Takagi, A Duoplasmatron with a Nozzle Type Plasma Expansion Cup, Proc. 2-nd Symposium on Ion Sources and Formation of Ion Beams, II-5, 1974.
3. C.D. Curtis, R.W. Goodwin, E.R. Gray, P.V. Livdahl, C.W. Owen, M.R. Shea and D.E. Young, The Operation of the First Section of the MBL Linear Accelerator, Particle Accelerators 1, 93 (1970).
4. M.D. Gabovich, L.L. Pasechnik and L.I. Romanyuk, Plasma Penetration Boundary and Plasma Focusing, Soviet Physics-Technical Physics 6 61, 1961.
5. H. Ishimaru, T. Sakaue, K. Ito, K. Muto and S. Fukumoto, 750 keV Beam Monitoring at the KEK, Proc. this Conf.
6. C.R. Emigh, E.A. Meyer, D.W. Mueller, Test of LASL Ion Source with 750 kV Accelerating Column, Proc. 1970 Proton Linear Accelerator Conf., p.1007, Sept. 1970.

DISCUSSION

C.D. Curtis, FNAL: When you operated the column at 600 mA, you showed a loss down to \sim 200 mA at the end of the transport line. Did you find this transmission to improve after a long period of operation because of increase in the proton percentage of the beam?

Ishimaru: We did not observe an improvement.