

## 750 KEV BEAM MONITORING AT THE KEK

H. Ishimaru, T. Sakaue, K. Itoh, K. Muto and S. Fukumoto  
National Laboratory for High Energy Physics  
Oho-machi, Tsukuba-gun, Ibaraki, 300-32, Japan

### Abstract

Various diagnostic devices have been built and used to measure the properties of the KEK preinjector beams. The mechanical and electrical design and characteristics of the current transformers, Faraday cups, fluorescent screen and three kind of emittance probes are described.

### Introduction

First 750 keV ion beam had been monitored by seven current monitors from the column to the linac on 24 July 1974. Beam size and position were measured by a fluorescent screen on 4 Aug. 1974. Beam emittance was obtained with pepper pot method on 12 Feb. 1975.

To improve the monitor system efforts have been continued. Recently, computer controlled beam current measurements and beam emittance measurements have been operated routinely.

The design of the mechanical and electrical components of the monitoring and the beam measurements will be presented.

### Current Transformers and Faraday Cups

The beam parameters to be measured are 10 mA ~ 600 mA beam currents, 0.5  $\mu$ sec ~ 30  $\mu$ sec pulse width and 1 ~ 20 pps repetitions. Beam intensity is measured using 7 toroidal current transformers. The transformer is 72 mm in diameter and 15 mm thick with a core of Mn-Zn ferrite of  $14 \times 9$  mm cross section. The winding is a single layer of 245 turns with 0.5 mm in diameter holmal wire. After winding, the core is placed in stainless steel electrostatic shielding case, 0.1 mm in thickness. The transformer is located within the vacuum chamber. The shielding case is filled with epoxy and is welded by electron beam vacuum tightly as shown in Fig.1. The small holes for the lead wire extension are only exposed epoxy to vacuum. Measurements of the inductance and the resistance of the transformer give values of 0.12  $\Omega$  and 1.6  $\Omega$  respectively. A single turn loop is also wound around the transformer, with termination of 50  $\Omega$ . This is used for calibration purpose. The 50  $\Omega$  impedance allows the remote placement of the electronic circuits from the transformer by matching the coaxial cable impedance. Signal rise time of about 100 nsec can be observed. A sensitivity of 13 mV/ 100 mA, with a droop of 1 % per 30  $\mu$ sec has been achieved. The output signals of the monitor are reduced to 65 % of a monitor which is not completely enclosed with a metal plate. Fig.2 shows the oscillogram for the output signal vs. the calibration pulse. The output signal from the beam is shown in Fig.3.

The beam current information is displayed as follows. Each signal conditioner which consists of an amplifier, a sample/hold circuit and a buffer amplifier is interfaced to the mini-computer to provide the operator with digital readout and the (x,t) record. An analog multiplexer and an analog/digital

converter are interfaced to the mini-computer. This electronic diagram is shown in Fig.4. The output signal of the sample/hold circuit corresponding to the linac beam is displayed on the (x,t) recorder as is shown in Fig.5. It shows the continuous current variation of linac output. The digital readout on the printer is shown in Fig.6. For computer system, the output connector of the current transformer should be isolated from the vacuum chamber to reduce the loop noise. Then insulated BNC-vacuum feedthrough was developed<sup>1)</sup> as shown in Fig.7.

Current transformers are checked by a biased Faraday cup in combination with a calorimetric detector. To suppress the secondary electron emission the suppressor electrode and the deep Faraday cup is employed. Negative bias voltage of 2 kV is applied. Output waveform of the Faraday cup is shown in Fig.8, which agrees with the magnitude of the current from the toroidal current transformer within  $\pm 10$  %. A calorimetric measurement also agrees within  $\pm 10$  % to the value of the toroidal transformer.

### Fluorescent Screen

The fluorescent screen of aluminum coated quartz plate has been used for observing the size and shape of an ion beam. The beam image is displayed on the picture monitor by TV camera.

### Emittance Probes

The first stage, the beam emittance was measured by a photographic pepper pot method at the entrance of the linac. The head of the emittance monitor is shown in Fig.9. The detector consists of a multi-hole disk made of copper and aluminum coated quartz prism. A pepper pot pattern is shown in Fig.10. The normalized emittance is estimated to be less than  $0.4 \pi$  cm m in both directions. Although this method is troublesome and time consuming, the accuracy of the result is not satisfactory.

The second stage, beam emittances were measured by analog electronic method at two points. 1.5 m upstream and the just front of the linac. Emittance probes used to obtain the beam of the density profile, and the phase space shape consists of a single slit, a drift space, and a 24-segment detector. A positive voltage of 200 volts is applied to the single slit to suppress the secondary electron produced by proton beam impinging on the slit and ionizing the residual gases. Each ion collector is separated by the intermediate grounded plates. A drift space and ion collector are covered with stainless steel box to shield electrostatically. This assembly is then scanned across the beam. Density profile and focal condition are displayed on the storage scope. Emittance data is acquired in 31 beam pulses. There is only one emittance probe at each position, so the polarity of the all quadrupole magnets is changed quickly. Then emittance of x-x' and y-y' plane can be measured. The dimensions and characteristic parameters are shown in Table I. A schematic diagram of the electronic emittance probe is shown in Fig.11. A photo of the emittance monitor

head is shown in Fig.12. The signal processing and display are performed without computer. The output signal from the sample/hold circuit with 24-ch analog multiplexer is fed to z-axis of a storage scope through a level comparator, a gated pulse train generator and a pulse amplifier. The signal of the 31 steps staircase generator which is triggered by sampling pulse of the sample/hold circuit is fed to y-axis of the scope. Zero level drift of the output signal from analog multiplexer is the order of 5 mV, and S/N ratio corresponds to more than 100. Two-dimensional emittance diagram is shown in Fig.13. A dot corresponds to  $0.016 \pi \text{ cm mr}$  which is normalized value. To display a three dimensional emittance diagram on the scope, mixed signal of the output of the analog multiplexer and the staircase output is fed to y-axis of the scope. A photo of the three-dimensional display is shown in Fig.14.

The scanning mechanism consists of dynamic bellows, ball screw, ball bush and external triggered pulse motor as shown in Fig.15. The position is monitored by a linear potentiometer with accuracy of  $\pm 0.1 \text{ mm}$ . This probe is useful for adjustment of the beam line, because it gives quick displays of the emittances.

The third stage, a case of computer controlled emittance measurements, the signal from the sample/hold circuits is fed to the computer through the differential buffer amplifiers, the gain of which is about 10. Because these emittance probes give destructive measurement, signals from two probes are locally sub-multiplexed to send to the computer. The data collection time for 30 steps is about 15 seconds. The emittance display on the large storage scope requires about 3 minutes. A block-diagram of the computer controlled emittance measurements is shown in Fig.16. The digital printout of the output from the sample/hold circuits is shown in Fig.17. This printout shows the three dimensional phase space emittance diagram. Abscissa is the radial distribution and ordinate is the angular distribution. At present, a mini-computer Melcom 70 with a 8 bits 48 Kwords memory is being used. The emittance display represents the beam profile, the phase space shape, the intensity distribution and the emittance area v.s. beam intensity. The contours refer to beam properties as dotted area; one-dot is 100 % emittance, two-dots is 80 % emittance, three dots is 60 % emittance and so on. Most one-dot contour is estimated for noise in digital printout. Emittance area of a 750 keV beam line is seemed to be  $0.3 \sim 0.4 \pi \text{ cm mr}$  in the horizontal and vertical planes for 80 % of beam intensity of 230 mA.

To improve the angular resolution of the emittance probe, the ion collector will increase 24 channel to 32 channel and the spacing of the ion collector will decrease.

#### Future Development

As future development of the fourth stage emittance probe, the fast measuring emittance probes will be installed. This fast probe consists of a fast scanning mechanism, and a single slit, a single collector, a electronic sweeper and the fast transient recorder-computer assembly.

We would like to thank Prof. T. Nishikawa for his encouragement.

The authors acknowledge the advice for the electronics of Dr. S. Shibata. The authors would like to thank Dr. K. Uchino for his work in the soft and hardware of interface to computer.

#### Reference:

- 1) H. Ishimaru, Vacuum 26, No.6, (1976)
- 2) R.W. Goodwin, et.al., LCO-058, 1970 Proton Linear Accelerator Conference

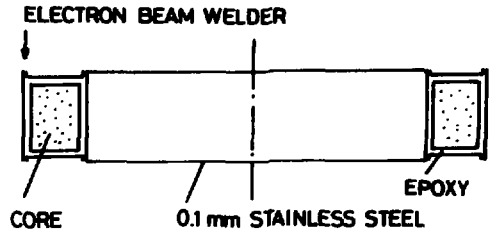

Fig.1 The cross section of the completely shielded current monitor.



Fig.2 upper: output signal 5 mV/div. lower: calibration pulse 2 V/div. sweep: 5  $\mu\text{sec/div}$ .



Fig.3 Signal from the current transformer for direct measurement in 750 keV line. sweep: 5  $\mu\text{sec/div}$ . range: 10 mV/div.

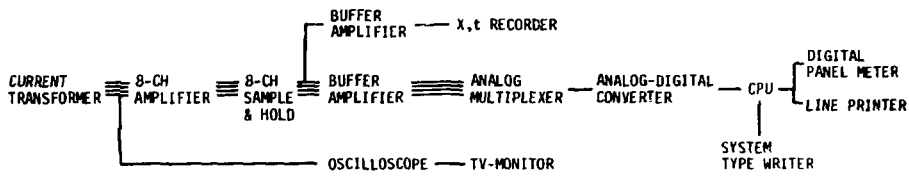

Fig.4 Electronic diagram for digital display.

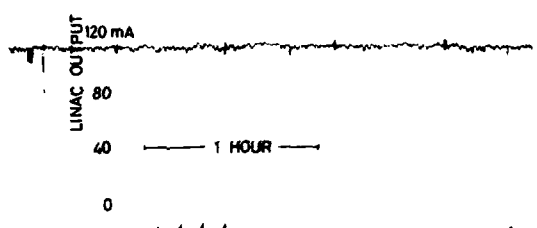

Fig.5 Continuous current variation for linac output.

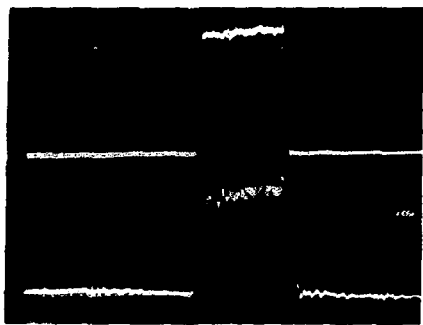

Fig.8 a) Output from the current transformer.  
b) Output from the biased Faraday cup.

BEAM CURRENT CM-1	598 MA	750 KEV, BEFORE LBT
BEAM CURRENT CM-2	341 MA	AFTER STEERING
BEAM CURRENT CM-3	336 MA	"DRUM EXIT
BEAM CURRENT CM-4	345 MA	BEFORE E. S. CHOPPER
BEAM CURRENT CM-5	302 MA	AFTER COLLIMATOR
BEAM CURRENT CM-6	337 MA	BEFORE BUNCHER
BEAM CURRENT CM-7	255 MA	AFTER BUNCHER, LINAC INPUT
BEAM CURRENT IM-1	148 MA	LINAC OUTPUT

Fig.6 Digital printout for beam current by mini-computer.

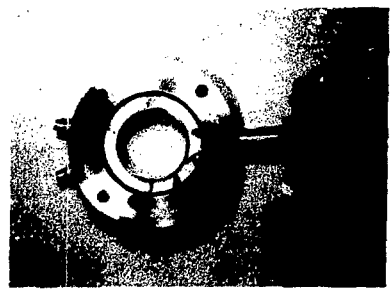

Fig.7 Vacuum tight shielded current monitor installed in monitor unit, the insulated BNC-vacuum feedthrough and small ion pump for vacuum gauge.

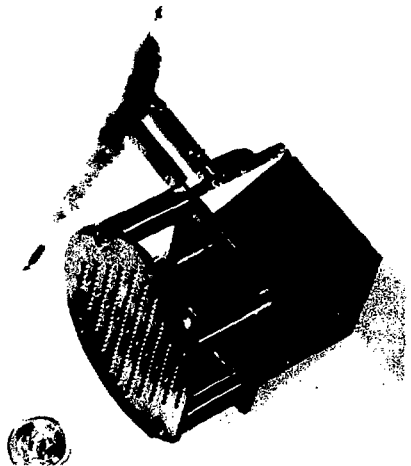

Fig.9 First stage emittance probe.

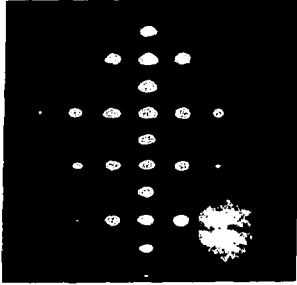

Fig.10 Pepper pot pattern.

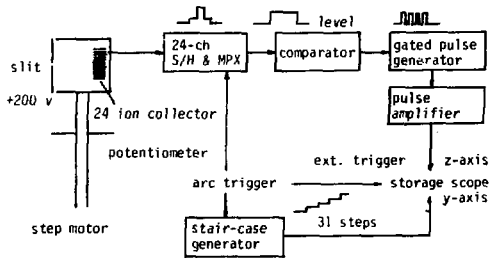
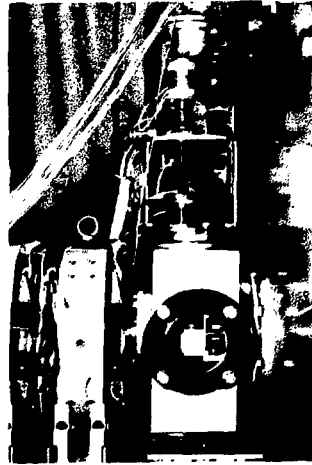
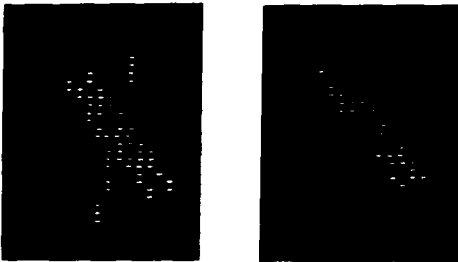

Fig.11 A schematic diagram of the electronic emittance probe, a case of two-dimensional emittance measurement.



a b

Fig.13 Two-dimensional emittance diagram. a) comparator level is low, b) is high.

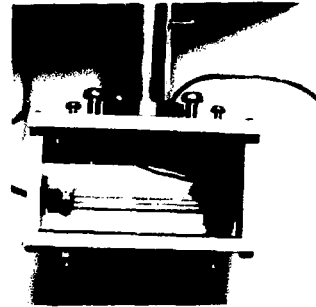

Fig.12 A head of the emittance monitor and a driving mechanism.

	slit width	drift space	coll. width	coll. spacing	$\Delta\theta$	$\Delta X, \Delta Y$	$\frac{\delta Y}{\pi} \Delta\theta \Delta X(Y)$
probe I	0.2 mm	111 mm	0.3 mm	0.3 mm	5 mr	0.14 cm	0.0089 cm·mr
probe II	0.2	54.5	0.1	0.18	5.7	0.22	0.016

Table I The dimension and characteristic parameters of the emittance probes.

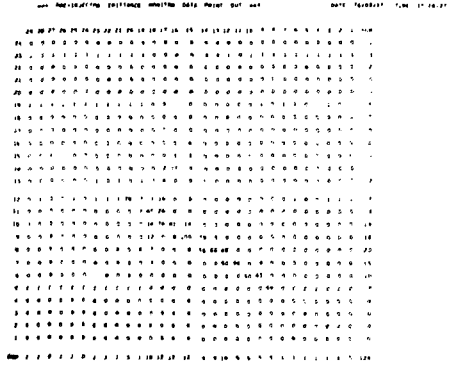
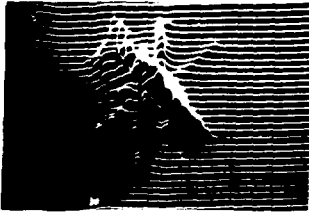

Fig.16 Digital printout shows the three-dimensional phase space emittance diagram.

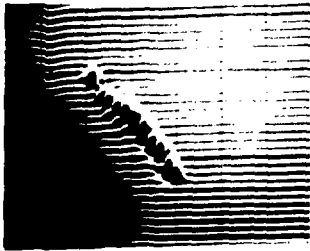

Fig.14 Three-dimensional phase space diagram.

Fig.17 Emittance display in KEK pre-injector.

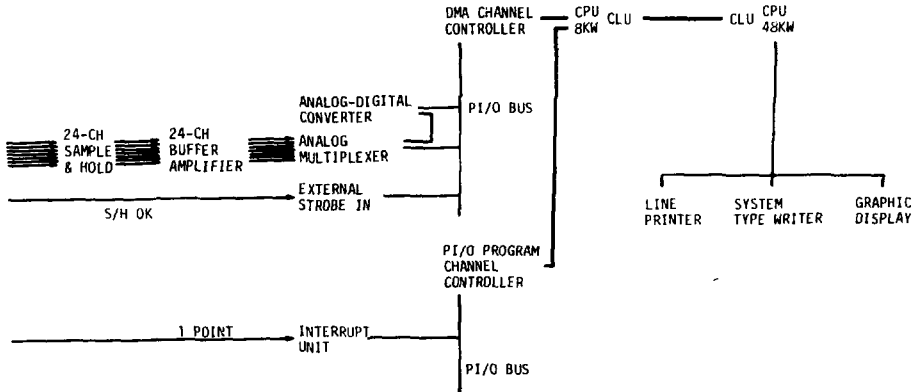

Fig.15 A block-diagram of the computer controlled emittance measurement.

## DISCUSSION

M.R. Shubaly, CRNL: What was the proton percentage in the beam and are your emittance measurements taken only on the proton component of the beam or are they on all species?

Ishimaru: The proton percentage in the beam is estimated at 85% from measurement in the test ion source. In the illustration of the two-dimensional emittance display (Fig. 13) at low comparator level the small percentage contributions from  $H^{++}$  and  $H^{3+}$  can be seen.

R.L. Witkover, BNL: I noticed that the slit of the emittance probe had a bias voltage. Have you observed any effect of this voltage upon the measurement?

Ishimaru: Yes, there was a 5% offset which was eliminated by the bias. No rotation of the emittance was seen.