



**A MONTE CARLO CODE (PHOEL) FOR
GENERATING INITIAL ENERGIES OF PHOTOELECTRONS
AND COMPTON ELECTRONS PRODUCED BY PHOTONS IN WATER**

**J. E. Turner, J. T. Módolo, G. M. A. A. Sordi,
R. N. Hamm and H. A. Wright**

**INFORMAÇÃO IEA 068
IEA - Inf - 068**

FEVEREIRO/1979

CONSELHO DELIBERATIVO

MEMBROS

Klaus Reinach -- Presidente
Roberto D'Utra Vaz
Helcio Modesto da Costa
Ivano Humbert Marchesi
Admar Cervellini

PARTICIPANTES

Regina Elisabete Azevedo Beretta
Flávio Gori

SUPERINTENDENTE

Rômulo Ribeiro Pieroni

**A MONTE CARLO CODE (PHOEL) FOR
GENERATING INITIAL ENERGIES OF PHOTOELECTRONS
AND COMPTON ELECTRONS PRODUCED BY PHOTONS IN WATER**

J. E. Turner, J. T. Mòdolo, G. M. A. A. Sordi,
R. N. Hamm and H. A. Wright

CENTRO DE PROTEÇÃO RADIOLÓGICA E DOSIMETRIA
CPRD - AMD 002

INSTITUTO DE ENERGIA ATÔMICA
SÃO PAULO - BRASIL

CONTENTS

	<u>Page</u>
Abstract	1
1. Introduction	1
2. Treatment of Compton Electrons	2
3. Treatment of Photoelectrons	4
4. Input Photon Spectrum	5
5. Operation of the Code	6
6. Numerical Checks of PHOEL	10

A MONTE CARLO CODE (PHOEL) FOR GENERATING INITIAL ENERGIES
OF PHOTOELECTRONS AND COMPTON ELECTRONS PRODUCED BY PHOTONS IN WATER

J. E. Turner, J. T. Modolo,* G. M. A. Sordi,* R. N. Hamm and A. Wright

ABSTRACT

A Monte Carlo Code, PHOEL, is described for generating the initial energies of Compton and photoelectrons in water irradiated by photons with an arbitrary energy spectrum. An infinite, homogeneous water phantom is assumed in which the photon spectrum is uniform throughout. The neglect of pair production does not represent a significant omission for photons with energies below about 10,000 keV. The code PHOEL was written specifically to provide a source term for a Monte Carlo electron energy degradation and transport code for liquid water being used to study the relative biological effectiveness (RBE) of low-LET radiations at low doses. The basic numerical data used in PHOEL and their mathematical treatment are described as well as the operation of the code. Copies of the program are available from the Radiation Shielding Information Center at Oak Ridge National Laboratory. Some numerical computations which have been made for verification of the code are briefly described. The code processes 1000 photons at 200 keV in less than 2 sec on the IBM 360/91. Because of multiple Compton scattering, the processing of higher-energy photons takes somewhat longer. The code has options for printing the electron energies and/or writing them on tape or disc.

1. INTRODUCTION

The Monte Carlo code PHOEL was written to generate the initial energies of electrons produced in water by photons having a specified energy spectrum. PHOEL produces a source term for a detailed Monte Carlo code for calculating electron transport and energy degradation in liquid water.¹ The latter code has been used to calculate electron slowing-down spectra, secondary-electron dose distributions, and yields (G values) for various products in liquid water. Such calculations have been applied to study relative biological effectiveness (RBE) for low-LET radiations at low doses.² Most recently, PHOEL has been incorporated into the electron code to study RBE for photons of different energies.³ It is the purpose

Published in Oak Ridge National Laboratory in September/1978. Contract No. W-7405-eng-26.

- HEALTH AND SAFETY RESEARCH DIVISION.

ORNL/TM-6515

Dist. Category UC-41.

* Instituto de Energia Atômica, São Paulo, Brazil

of this report to document the information in PHOEL and explain how the code can be used. Copies of the code are available from the Radiation Shielding Information Center, Oak Ridge National Laboratory, Oak Ridge, Tennessee.

The code applies to an infinite, homogeneous water phantom irradiated uniformly with photons of a specified energy spectrum. Pair production is neglected.

Energies are specified in kilo-electron volts (keV) throughout.

2. TREATMENT OF COMPTON ELECTRONS

The cross section $d\sigma/dT$ for producing Compton electrons of kinetic energy T is given by Eq. (26.7) of Evans' review⁴:

$$\frac{d\sigma}{dT} = \frac{\pi r_0^2}{\alpha^2 m_0 c^2} \left\{ 2 + \left(\frac{T}{E-T} \right)^2 \left[\frac{1}{\alpha^2} + \frac{E-T}{E} - \frac{2}{\alpha} \frac{E-T}{T} \right] \right\} \frac{\text{cm}^2}{\text{keV electron}} \quad (1)$$

Here

$$r_0 = \frac{e^2}{m_0 c^2} = 2.18 \times 10^{-13} \text{ cm} = \text{"classical electron radius"},$$

$$m_0 c^2 = 511 \text{ keV} = \text{electron rest energy},$$

$$E = \text{photon energy in keV},$$

$$\alpha = \frac{E}{m_0 c^2}$$

$$T = \text{kinetic energy of Compton electron in keV}.$$

The cumulative distribution for producing a Compton electron of energy T or less can be found by integrating Eq. (1). We find for the (unnormalized) cumulative distribution

$$S(E, T) = \int_0^T \left(\frac{d\sigma}{dT} \right) dT = \frac{\pi r_0^2 T}{\alpha^2 m_0 c^2} \left[\frac{2E-T}{2E} + \frac{2}{\alpha} + \frac{2E-T}{\alpha^2 (E-T)} - \frac{E}{T} \right. \\ \left. \left(1 - \frac{2}{\alpha} - \frac{2}{\alpha^2} \right) \ln \left(1 - \frac{T}{E} \right) \right] \quad (2)$$

The kinetic energy of the Compton electron can vary from zero to a maximum value given by⁴

$$T_{\max} = \frac{2\alpha E}{1 + 2\alpha} \quad (3)$$

The normalized cumulative electron distribution, therefore, is given by

$$P(E, T) = \frac{S(E, T)}{S(E, T_{\max})} \quad (4)$$

To obtain the energy of a Compton electron produced by a given photon of energy E , the quantity $S(E, T_{\max})$ is first calculated in PHOEL. A random number between 0 and 1 is chosen for P , and the equation

$$S(E, T) - PS(E, T_{\max}) = 0 \quad (5)$$

is solved to obtain T . The method of solution is as follows. By definition, the distribution $S(E, T)$ is a monotonically increasing function of T . Therefore, whenever $0 < P < 1$, the difference $S(E, T) - PS(E, T_{\max})$ will be the positive for T near T_{\max} and negative for T near zero, and it will change sign once in the interval (namely, at the root implied by Eq. (5)). Starting at $T = T_{\max}$, the code calculates $S(E, T) - PS(E, T_{\max})$ at successive values

$$T = T_{\max} (1 - 0.1 J) \quad \text{with } J = 0, 1, \dots, 10 \quad (6)$$

until it changes sign or is zero. When the sign change occurs, say, between values T_1 and T_2 , PHOEL next steps through the interval $T_1 - T_2$ in steps of $\Delta T = 0.1 (T_1 - T_2)$, starting at T_1 and finds where $S(E, T) - PS(E, T_{\max})$ again changes sign or vanishes. The new interval thus determined is further subdivided into tenths for finding a third approximation to the root, which is taken to be the arithmetic mean of the endpoints of this third interval. If, during this procedure, $S(E, T) - PS(E, T_{\max})$ vanishes, then the corresponding value of T is the root.

3. TREATMENT OF PHOTOELECTRONS

The mass attenuation coefficients for K-shell photoelectron production by photons of different energies in water have been given by Evans.⁵ At a photon energy $E = 10$ keV the photoelectric effect dominates, the Compton mass attenuation coefficient being less than 5% of the total. PHOEL allows Compton electrons to be produced when $E > 8$ keV. Only photoelectrons are produced at lower energies.

When the photon has an energy E below 8 keV but greater than the binding energy of the K electron in oxygen (0.532 keV), it is assumed that it produces an oxygen K-shell photoelectron with energy $T = E - 0.532$ keV. Since the fluorescent yield for oxygen is essentially zero, it is assumed that the K vacancy is filled by an L electron with emission of an Auger electron of energy $T = 0.508$ keV, 0.024 keV being used as an average value for the binding energy of the L electron in oxygen. Thus, two electrons of the stated energies are produced as a result of K-shell photoelectric ionization.

Below the K-shell ionization threshold, it is assumed that a photon of energy E produces an L photoelectron from oxygen with energy $T = E - 0.024$ keV as long as $E > 0.024$ keV. If the photon energy is less than this amount, it produces no further interactions. The number and total energy of such low-energy photons are tabulated and printed by PHOEL.

The following summarizes the treatment of the lowest energy photons in PHOEL (all energies in keV):

$E \leq 0.024$	number of photons and total energy tabulated
$0.024 < E \leq 0.532$	L-shell photoelectrons produced from oxygen with $T = E - 0.024$
$0.532 < E \leq 8$	K-shell photoelectrons produced from oxygen with $T = E - 0.532$ followed by Auger electron with $T = 0.508$.

Above 8 keV, the photoelectric and Compton processes begin to compete. Whereas the photoelectric effect accounts for more than 95% of the mass attenuation coefficient in water at 10 keV, it accounts for less than 5% at 70 keV, where the photoelectric effect is cut off in PHOEL. The ratio of the photoelectric and photoelectric-plus-Compton mass

attenuation coefficients between 8 and 70 keV is fit approximately by two line segments intersecting at $E = 37$ keV. The equations of the line segments are (energies in keV):

$$X(E) = 1.218 - 0.0272E \quad \text{for} \quad 8 < E \leq 37 \quad (7)$$

$$X(E) = 0.445 - 0.00636E \quad \text{for} \quad 37 < E \leq 70 \quad (8)$$

The value of $X(E)$ thus gives the fraction of events that produce photoelectrons at photon energy E , with $X(8) = 1$ and $X(70) = 0$.

When a photon with energy E between 8 and 70 keV occurs in PHOEL, a random number R between 0 and 1 is chosen. The difference $R - X$ is formed, Eq. (7) being used if $8 < E \leq 37$ and Eq. (8) if $37 < E \leq 70$. If $R - X \geq 0$, then a Compton electron is produced by the photon; otherwise, it produces a photoelectron from the oxygen K shell.

4. INPUT PHOTON SPECTRUM

PHOEL is written to read a continuous photon spectrum described by pairs of values of energy $ER(J)$ and cumulative probability $D(J)$ of having a photon with energy less than $ER(J)$. Table 1 illustrates an example of a cumulative photon spectrum for 200-kvp x rays based on data given by Cormack and Johns⁶ for a spectrum of Greening.⁷ The spectrum is represented here by picking nine pairs of values $ER(J)$ and $D(J)$ as indicated. The number N of pairs of values is an input parameter in PHOEL, $N \leq 30$ being allowed. The first pair always gives the end of the distribution, so that $D(1) = 1.00$, and the points run successively to lower values of $ER(J)$ and $D(J)$. The last point is chosen such that $D(N) = 0.00$.

To pick the energy $E(I)$ of a photon from the distribution, a random number $R1$ between 0 and 1 is chosen in the code ($0 < R1 < 1$). The difference $R1 - D(J)$ is tested sequentially for $J = 2, \dots, N$ to see when it first goes negative. (Since $D(1) = 1$ always, the test begins with $J = 2$.) When $R1 - D(J)$ first goes negative, the photon energy $E(I)$ is chosen from the interval $ER(J-1) - ER(J)$ as follows:

$$E(I) = ER(J) + (ER(J-1) - ER(J)) (R1 - D(J)) / (D(J-1) - D(J)). \quad (9)$$

The number of photons to be used is specified by an input integer $NPHOT$.

Table 1. An example of 200-kvp x-ray spectrum^a

Photon energy (keV) ER(J)	Cumulative probability D(J)
170	1.00
150	0.99
140	0.98
115	0.95
85	0.74
70	0.57
50	0.22
36	0.03
22	0.00

^aBased on refs. 6 and 7.

The procedure just described applies to continuous photon spectra. Two special cases of line spectra are also handled by PHOEL. Cobalt-60 emits equal numbers of photons at two energies, 1170 and 1330 keV. If ⁶⁰Co is to be studied, then an input parameter MG is given a value different from zero. If $MG \neq 0$, then PHOEL selects $0.5 \cdot NPHOT$ photons with energy 1170 keV and the rest with energy 1330 keV. (In this special case, NPHOT must be an even integer.)

A monoenergetic spectrum of photons with energy ER(1) represents the second special case. Such a spectrum is specified in PHOEL by the single pair ($N = 1$) of values ER(1) and $D(1) = 1.00$. To assign the proper photon energy, PHOEL tests whether $N = 1$. If so, then the energy of every photon is taken to be ER(1). If $MG = 0$ and if $N \neq 1$, then PHOEL chooses photon energies by the method described for the continuous distribution.

5. OPERATION OF THE CODE

A flow chart of PHOEL is shown in Fig. 1 and a summary of the input cards in Table 2. The first card gives the title of the problem being run. The second card gives the number of photons NPHOT; the option

ORNL - ORG 70-14991

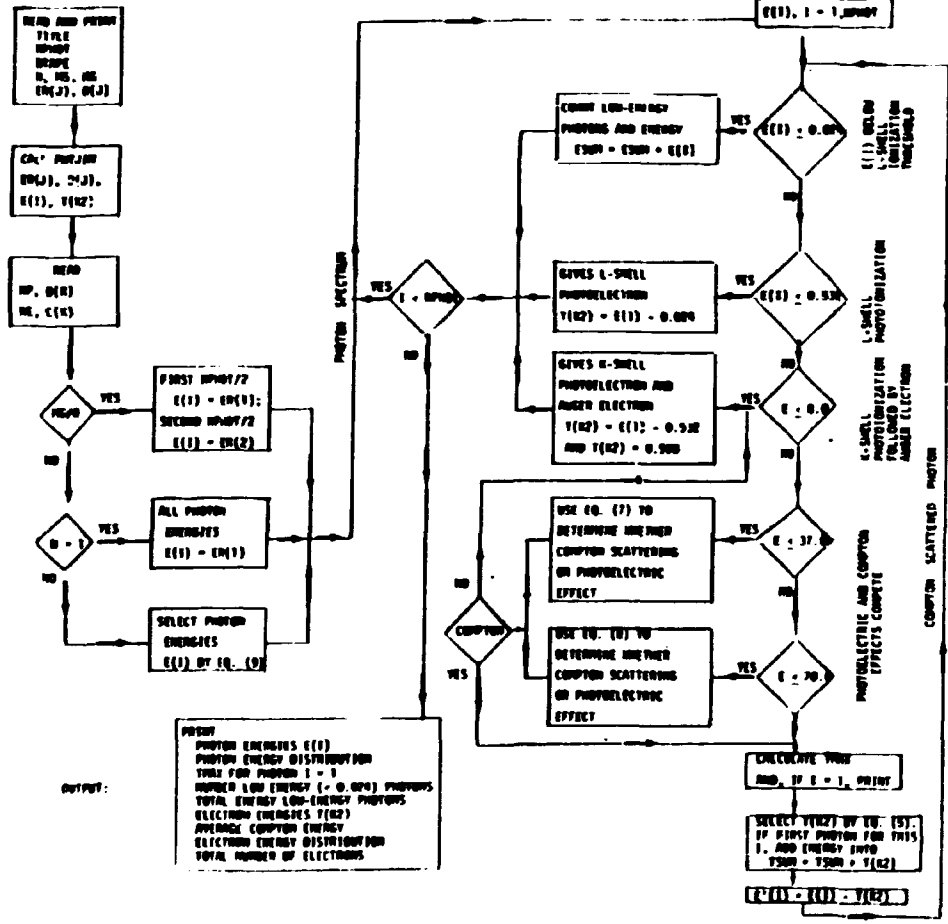

Fig. 1. Flow chart of PHOEL.

Card	Contents	Format
1	Title	(20A4)
2	NPHØT, NTAPE, N, M5, MG	(5I10)
3+	(ER(J), D(J), J = 1,N)	(10E8.2)
4+	NP, (B(K), K = 1, NP)	(15/16F5.0)
5+	NE, (C(K), K = 1, NE)	(15/16F5.0)
Explanations (also see text)		
NPHØT	=	Number of photons to be used
NTAPE	=	{ 0, ignored 1, write on disc
N	=	Number of points on cumulative photon spectrum ($N \leq 30$)
M5	=	Ratio of T(K2) to E(I) dimensions
MG	=	{ 0, not cobalt-60 1, cobalt-60 spectrum (NPHØT must be even integer)
ER(J), D(J)	=	Energies and cumulative probability for photon spectrum, $D(1) = 1.0$ and $D(N) = 0.0$
NP	=	Number of energy boundaries of bins for tabulating photons generated in PHOEL spectrum ($NP \leq 51$). Does not include Compton scattered photons.
B(K)	=	Energy boundaries for same.
NE	=	Number of energy boundaries of bins for tabulating electrons generated in PHOEL ($NE \leq 51$). Includes all electrons.
C(K)	=	Energy boundaries for same.

whether PHOEL prints the electron energies T on disc (NTAPE \neq 0) or does not (NTAPE = 0); the number N of pairs of values [ER(J), D(J)] that describe the photon spectrum ($N \leq 30$); the relative dimension M5 of the array for storing electron energies T(K2) compared with the array for photon energies E(I); and the option MG \neq 0 to generate the photon spectrum of ^{60}Co . The third and successive cards, if needed, give the [ER(J), D(J)]. The fourth and fifth cards are explained below.

The code first selects a photon energy E(I) from the input spectrum as described in Sect. 4. A series of tests of E(I) is then made, starting with the lowest energies as shown in Fig. 1, to determine the range in which the photon's energy lies. If $E(I) \leq 0.024$ or if a photoelectron is produced, then the photon disappears from the calculation and the program returns to the top to process a new photon. If a Compton scattering occurs, then the program calculates the Compton electron energy T by solving Eq. (5). Following the Compton scattering, a photon of reduced energy $E(I) = E(I) - T$ is recycled as indicated in Fig. 1. Photons from Compton scattering must eventually become degraded in energy and will disappear in the calculations through the photoelectric effect or through the low-energy exit $E \leq 0.024$. After processing the Ith photon from the original photon spectrum, if $I = \text{NPHOT}$, then the program goes to the output stage and ends.

Within the Compton scattering computation, a monitor has been set up to note the energy of the first Compton electron produced by a given photon. Subsequent Compton electrons produced by that photon ($I = \text{constant}$) after being degraded in energy are ignored in this monitor. The total energy TSUM of these first electrons for different values of I is computed and the average value TAVG = TSUM/NPHOT calculated at the end of the program. For a monoenergetic photon spectrum, TAVG gives the average Compton electron recoil energy, a value that can be checked by independent tables (e.g., refs. 4 and 5).

Finally, the output is arranged with self-explanatory legends for optional transfer to disc, printer, and/or tape. The spectrum of photons used is compiled in energy bins specified by the energy boundaries B(K) and their $\text{NP} \leq 51$ on the 4+ card(s). The spectrum of electrons is also compiled in bins specified by energy boundaries C(K) and their number $\text{NE} \leq 51$ on the 5+ card(s).

6. NUMERICAL CHECKS OF PHOEL

Values of TAVG with monoenergetic photons were computed for $E = 40, 100, 500, 1000, \text{ and } 5000$ keV with $NPHOT = 1000$. The numbers agree to within statistical expectations with values given in Table 8 of ref. 4 and Table III of ref. 5. As described above, TAVG gives the average energy of the first electron scattered by each new photon. It is thus equal to the average Compton electron recoil energy computed in refs. 4 and 5.

In addition, the distributions of electron energies that enter TAVG were calculated for $E = 100$ and 220 keV. The distributions agreed well with those given by Cormack and Johns in Table 2 of ref. 6, although PHOEL appears to give several percent more electrons at the lowest and the highest energies. The distribution of initial electron energies for ^{60}Co calculated with PHOEL is in agreement with that given by Cormack and Johns in Table 4 of ref. 6.

Finally, the routine for generating photon energies $E(I)$ from a continuous spectrum was checked by using a 200-kvp x-ray spectrum given by Greening⁷ and analyzed by Cormack and Johns.⁶

REFERENCES

1. R. N. Hamm, H. A. Wright, R. H. Ritchie, J. E. Turner and T. P. Turner, Proc. Fifth Symp. Microdosimetry, Verbania Pallanza, Italy, Sept. 22-26, 1975 (Commission of the European Communities, Luxembourg, March 1976), vol. II, p. 1037.
2. R. N. Hamm, H. A. Wright, R. Katz, J. E. Turner and R. H. Ritchie, Phys. Med. Biol. 23, 235 (1978).
3. J. E. Turner, R. N. Hamm, H. A. Wright, R. P. Ritchie and R. Katz, Proc. Sixth Symp. Microdosimetry, Brussels, Belgium, May 22-26, 1978, to be published.
4. R. D. Evans, Encyclopedia of Physics, S. Flügge, ed. (Springer, Berlin, 1958), vol. 34, pp. 218-298.
5. R. D. Evans, Radiation Dosimetry, F. H. Attix and W. C. Roesch, eds. (Academic, New York, 1968), 2nd ed., pp. 93-155. Similar information for water is included in Ref. 4.
6. D. V. Cormack and H. E. Johns, Brit. J. Radiol. 25, 369 (1952).
7. J. R. Greening, Brit. J. Radiol. 24, 204 (1951).

ORNL/TM-6515
Dist. Category UC-41

INTERNAL DISTRIBUTION

- | | | | |
|-------|----------------|--------|--|
| 1. | R. N. Hamm | 17-18. | C. R. Library |
| 2. | R. F. Hibbs | 19. | Document Reference Section |
| 3. | S. V. Kaye | 20-21. | Laboratory Records Department |
| 4. | H. Postma | 22. | Laboratory Records, ORNL RC |
| 5. | C. R. Richmond | 23. | ORNL Patent Office |
| 6-15. | J. E. Turner | 24-33. | Radiation Shielding Information Center |
| 16. | H. A. Wright | | |

EXTERNAL DISTRIBUTION

- 34-38. J. T. Módolo, Instituto de Energia Atômica, Cx. Postal: 11.049-Pinheiros, São Paulo, Brazil.
- 39-48. J. T. Módolo, Rua Prof. F. A. Madeira 190, 18530-Tietê, São Paulo, Brazil.
- 49-53. G. M. A. A. Sordi, Instituto de Energia Atômica, Cx. Postal: 11.049-Pinheiros, São Paulo, Brazil.
54. Director, Research and Technical Support, DOE-ORO, Oak Ridge, TN 37830.
55. G. Venkataramen, Division of Radiological Protection, Bhabha Atomic Research Centre, Trombay-Bombay 400085, India.
- 56-306. Given distribution as shown in TID-4500.



INSTITUTO DE ENERGIA ATÔMICA
Caixa Postal, 11049 – Pinheiros
CEP 05508
01000 – São Paulo – SP

Telefone: 211-6011
Endereço Telegráfico – IEATOMICA
Telex – 011-23592 IENA BR