

- (21) Application No 7827229
- (22) Date of filing 19 Jun 1978
- (23) Claims filed 19 Jun 1978
- (43) Application published  
3 Jan 1980
- (51) INT CL<sup>3</sup>  
H01J 35/18 // 35/30 35/32
- (52) Domestic classification  
H1D 10 2A 2X 32 9C2 9CY  
9G 9Y
- (56) Documents cited  
GB 1312039  
GB 530458  
GB 472296  
GB 365609
- (58) Field of search  
H1D  
H5R
- (71) Applicant  
Thoro-Ray Inc.  
Fort Worth,  
Texas,  
United States of America
- (72) Inventor  
Mortimer E. Weiss
- (74) Agents  
D. Young & Co.,

(54) Dental X-ray apparatus

(57) Intra-oral dental X-ray apparatus for panoramic radiography comprises a tubular target carrier 331 supporting at its distal end a target 338 having an inclined forward face. Image definition is improved by positioning in the path of the X-rays a window 313 of X-ray transmitting ceramic material, e.g. 90% oxide of Be, or Al, 7% SiO<sub>2</sub>. The target carrier forms a probe which can be positioned in the patient's mouth. X-rays are directed forwardly and laterally of the target to an X-ray film positioned externally. Optionally the probe is provided with a detachable sleeve having V-form arms of X-ray opaque material which serve to depress the tongue out of the radiation path and also shield the roof of the mouth and other regions of the head from the X-ray pattern. A part cylindrical lead shield 339 defines the X-ray beam angle.

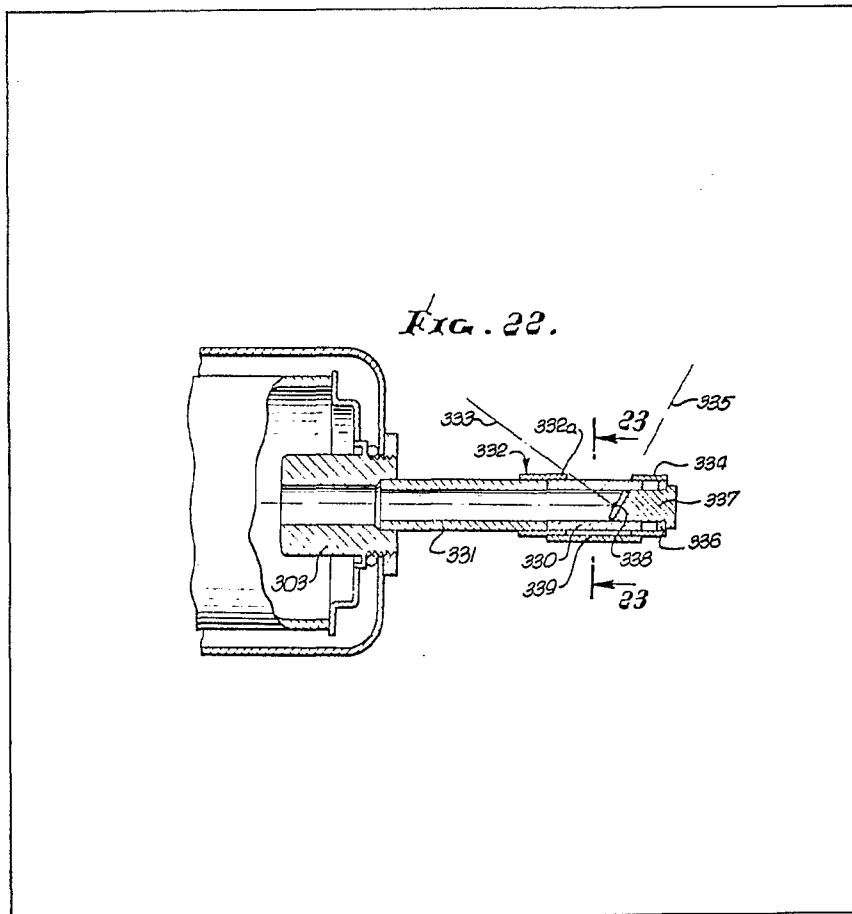

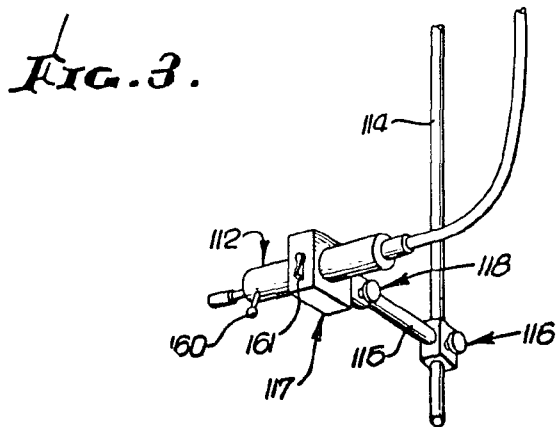
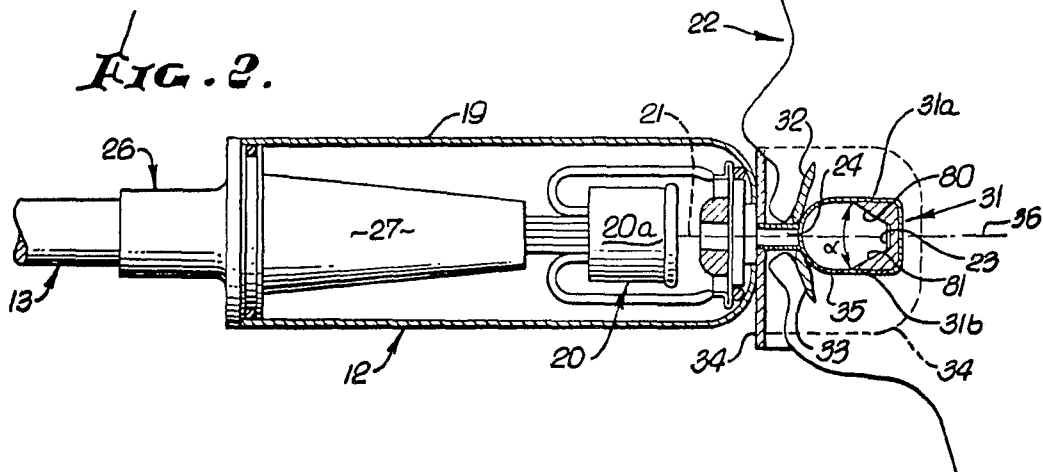
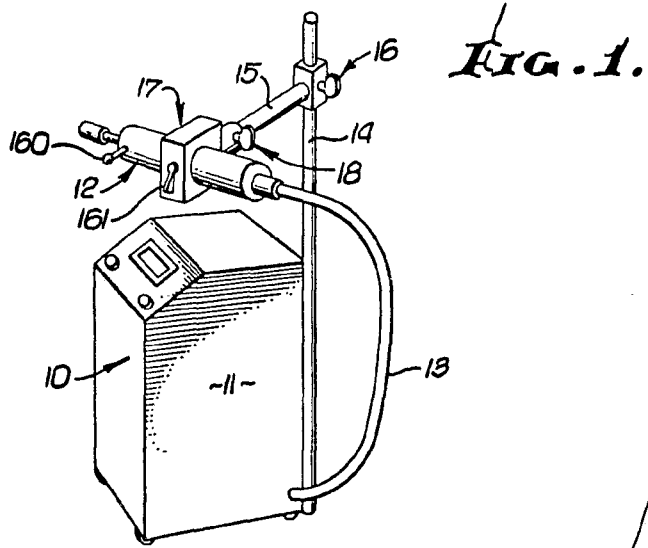

FIG. 8.

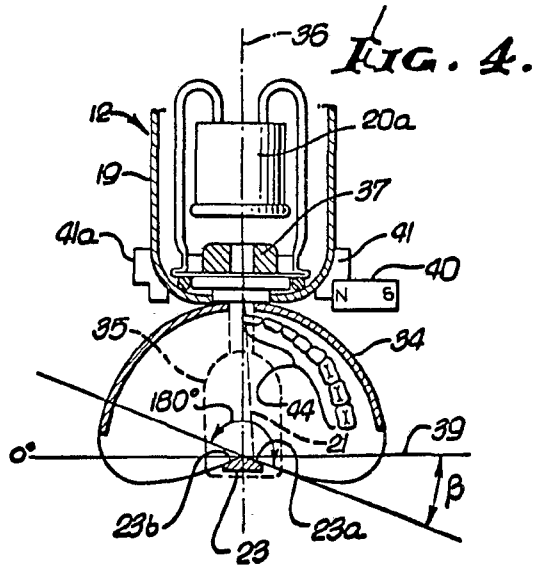
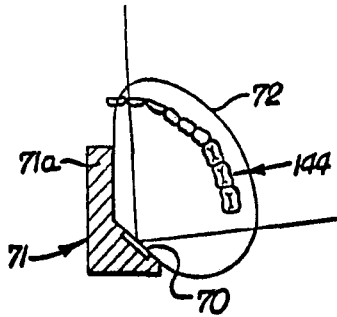

FIG. 5.

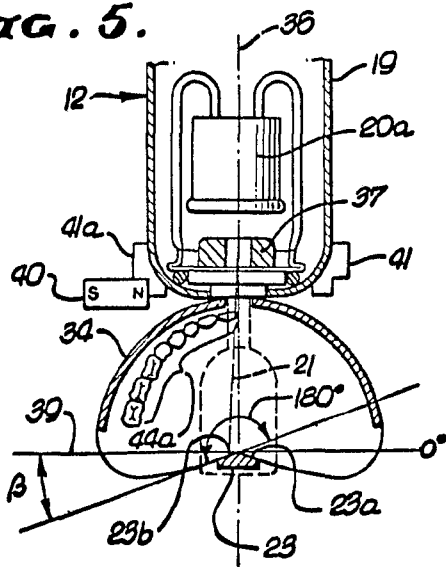

FIG. 7.

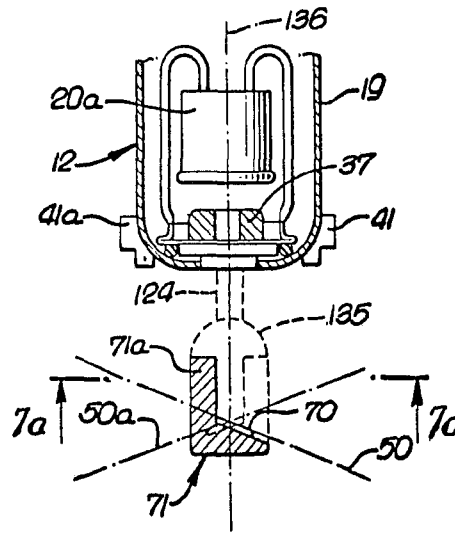

FIG. 6.

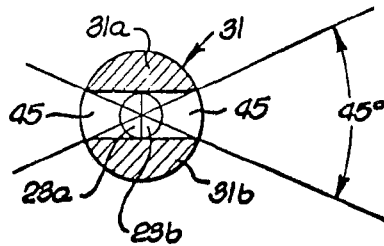

FIG. 7a.

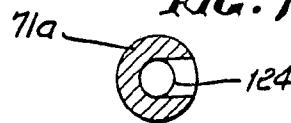

FIG. 9.

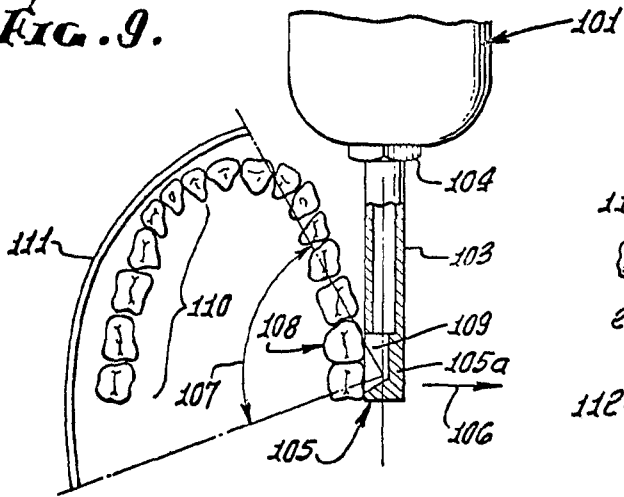

FIG. 10.

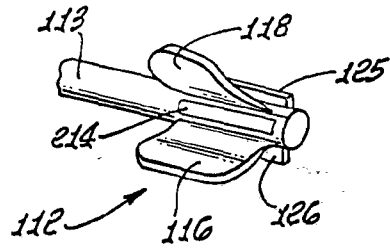

FIG. 12.

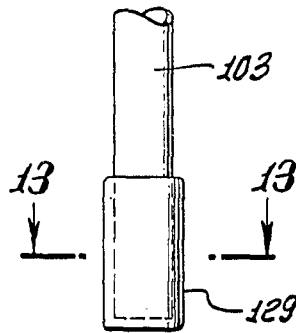

FIG. 11.

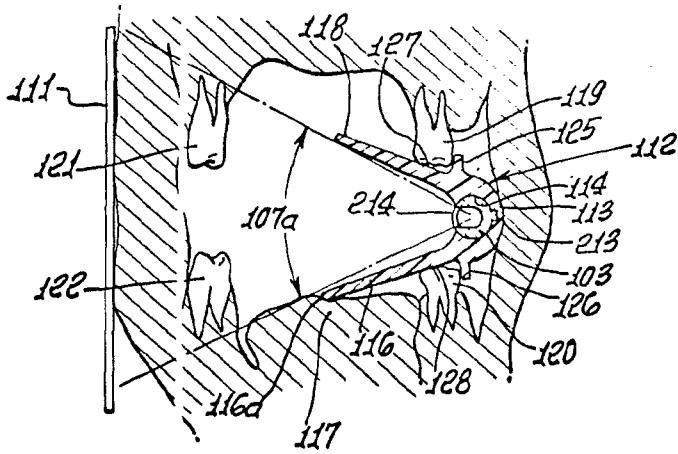
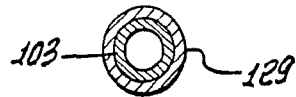
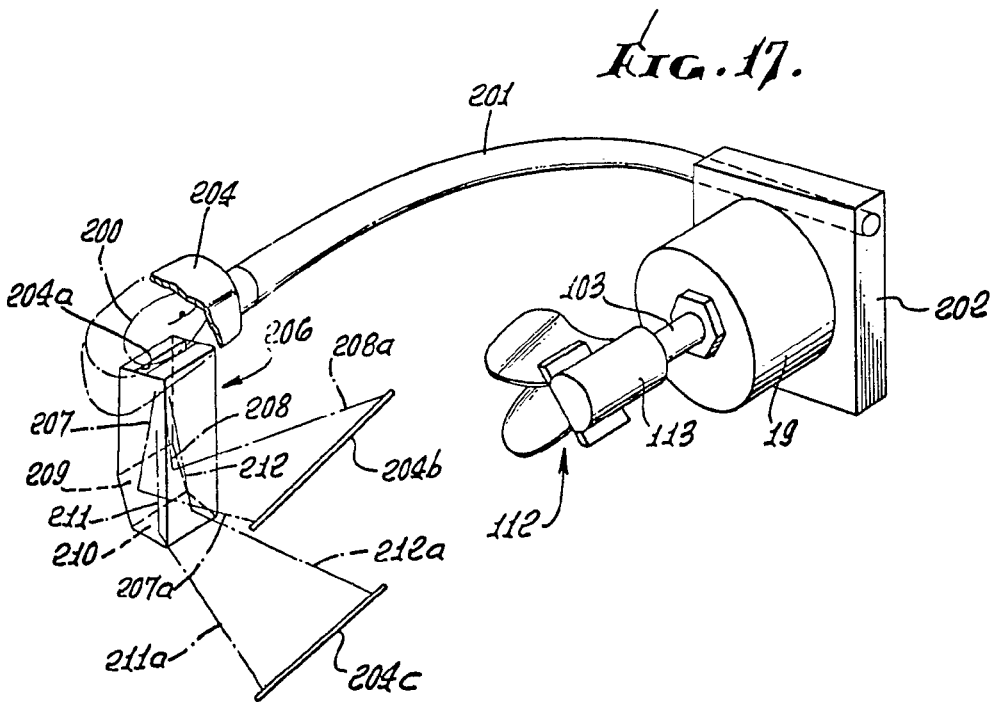
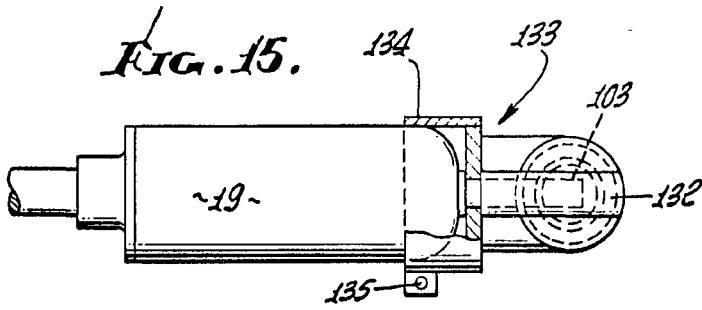
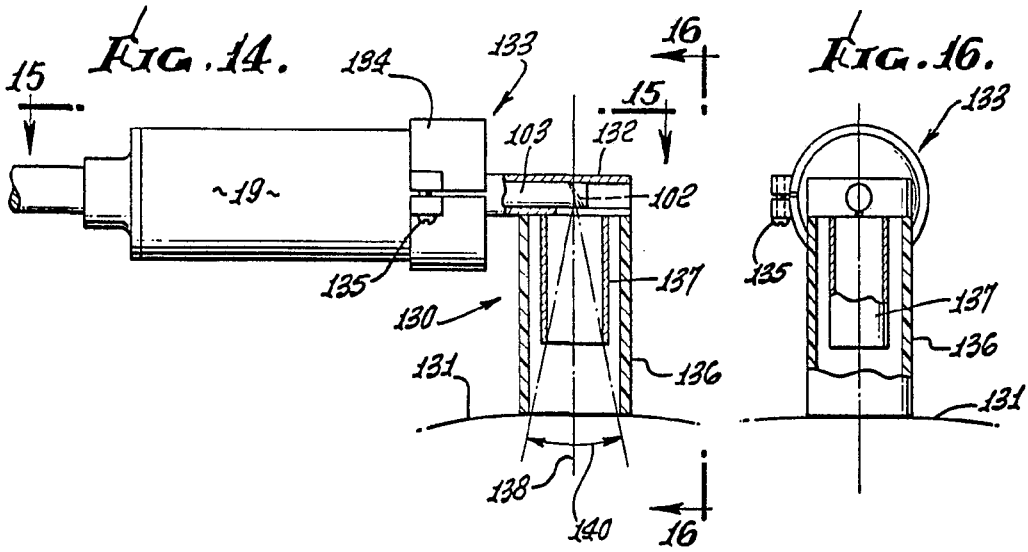
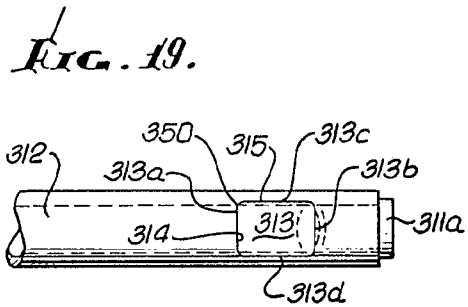
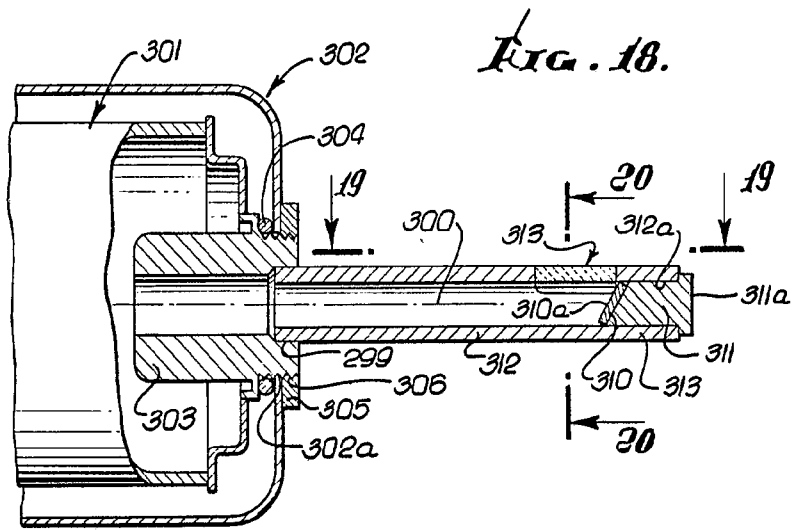

FIG. 13.







**FIG. 20.**

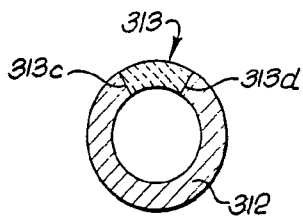

**FIG. 21.**

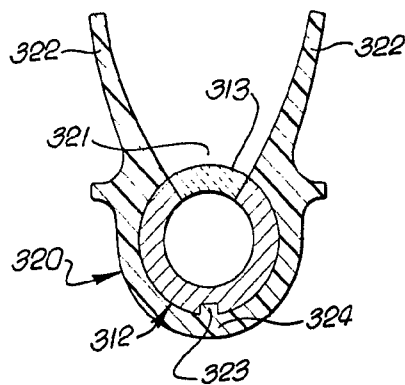

FIG. 22.

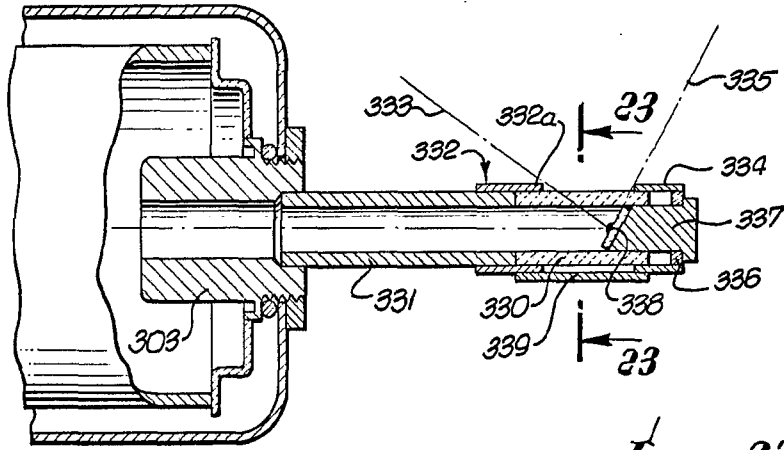

FIG. 23.

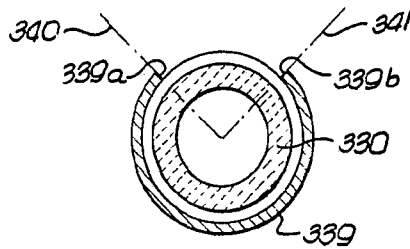

FIG. 24.

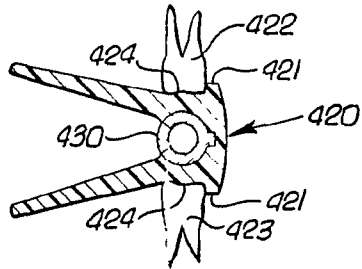

FIG. 26.

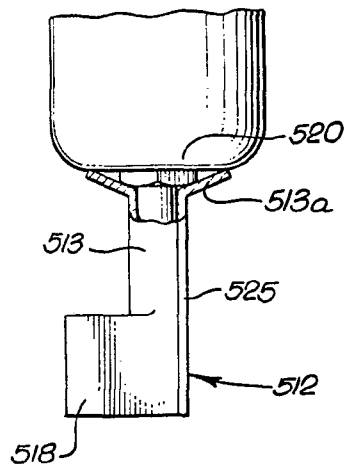
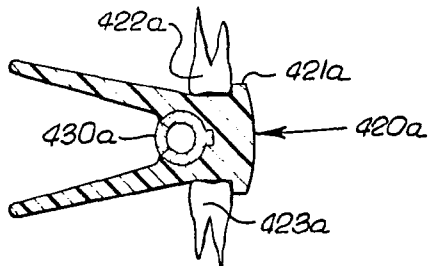

FIG. 25.



## SPECIFICATION

**Dental X-ray apparatus**

- 5 This invention relates to dental X-ray apparatus. 5
- Present systems of X-ray examination of human teeth require twelve to fourteen exposures, accompanied by objectionably excessive amounts of side radiation to sensitive areas of the brain, cortex, sinus, throat, optic and auditory nerve centres. Recently, a technique has been proposed according to which an X-ray target is introduced into the mouth, and radiation is directed from the target back through the teeth to film
- 10 supported outside the mouth, thereby to produce a so-called high resolution, panoramic radiograph. One problem encountered with that type of equipment concerns the tendency to produce gagging of the patient, due to the necessity of locating the target sufficiently close to the throat that back teeth will be exposed to produced X-rays. Another problem has to do with the requirement that the upper and lower teeth be alternately exposed to radiation, which in turn requires that the shield associated with the target be
- 15 re-arranged. This means that the target is removed from the oral cavity after the first exposure (as for example irradiation of the upper teeth), after which the target is re-introduced to enable the second exposure (of the lower teeth) which increases the risk of gagging and otherwise discomforts the patient. 15
- The present invention seeks to provide an improved dental X-ray apparatus for intra-oral X-ray and in particular one which provides on film improved, high clarity tooth images.
- 20 Basically, the apparatus of the present invention comprises an electron gun operable to direct an electron beam along an axis, a target carrier extending from said gun along said axis and having a distal end shaped to be received in a patient's mouth, a target carried by said carrier at said distal end and inclined with respect to the beam axis, a tubular X-ray shield positioned about said target coaxial with the beam axis, and a ceramic X-ray window located in said shield adjacent the inclined forward face of the target to pass X-rays
- 25 emanating from the target sideways from the beam axis to an X-ray film positioned externally of the patient's mouth. 25
- As will be seen, the ceramic X-ray window co-operates with the X-ray shield defined by the carrier, and in one form of the invention the window and shield are tubular and coaxial. In addition, an auxiliary semi-cylindrical X-ray shield may be located to extend around the ceramic element and to define certain
- 30 boundaries for X-rays passing through the window. Another such boundary may be defined by a sleeve extending about and positioning a portion of the ceramic element and carrier. 30
- In accordance with a preferred feature the invention also provides dental X-ray apparatus as above-defined in which the ceramic window co-operates with an X-ray shielding and tongue suppressor means so that when the target is located at one side of the mouth to direct an X-ray beam passing through
- 35 the ceramic window and toward teeth at the opposite side of the mouth, the shielding and tongue suppressor means will protect portions of the head from the X-ray beam and the patient's tongue will be suppressed relative to the X-ray beam. As will appear, the apparatus may include a tubular carrier for the target projecting rearwardly of the X-ray tube itself, and the shielding and tongue suppressor means may advantageously comprise a component having a base defining an opening removably receiving the tubular
- 40 carrier and ceramic element; further, that component may have arms which project sidewardly of the base with V-shaped configuration, the lower arm extending sufficiently downwardly and sidewardly as to suppress the patient's tongue when the base is received between the patient's upper and lower molars. In this regard, the referenced component may consist of plastic material containing X-ray shielding substance, as for example barium; and it may carry upper and lower projections to fit adjacent the outsides of the
- 45 patient's upper and lower molars for positioning purposes, and so that the molars may clench the component to position it for tongue suppression and shielding orientation relative to the mouth and head of the patient; also a longer source to film distance is enabled. 45
- The invention will be further described with reference to the accompanying drawings, particularly Figures 18-26 which illustrate the specific novel features of this invention. Figures 1 to 17 are provided to aid an
- 50 understanding of the subsequent Figures and to illustrate various embodiments of dental X-ray apparatus into which the novel features of the present invention can be incorporated. In the drawings: 50
- Figure 1* is a perspective showing of high voltage generator equipment and X-ray tube mobile or floor mount associated with the invention;
- Figure 2* is a cross-sectional view of gun and target apparatus embodying the invention;
- 55 *Figure 3* is a perspective showing of an alternative X-ray tube ceiling or wall mounting; 55
- Figures 4 and 5* are top plan views of gun and target relationships, in schematic form;
- Figure 6* is an enlarged frontal view of the target and shield;
- Figure 7* is a view like *Figure 4* in *Figure 5*, but showing an alternative target; and *Figure 8* shows another target;
- 60 *Figure 7a* is a section taken on lines *7a-7a* of *Figure 7*; 60
- Figure 9* is a view like *Figure 5*, showing modified apparatus wherein the target is located at one side of the patient's mouth;
- Figure 10* is a perspective view of an X-ray shield and tube positioning tongue suppressor attachment;
- Figure 11* is a vertical section taken through a patient's mouth showing use of the *Figure 10* attachment in
- 65 conjunction with an X-ray tube, target and carrier as for example is shown in *Figure 9*; 65



*Figure 12* is a plan view of a carrier for an X-ray producing target, and showing a filter on the carrier;

*Figure 13* is a cross-section taken on lines 13-13 of *Figure 12*;

*Figure 14* is a side elevation showing an attachment for the *Figure 9* apparatus, enabling its use externally of the patient's mouth;

5 *Figure 15* is a plan view taken on lines 15-15 of *Figure 14*;

5

*Figure 16* is an elevation taken on lines 16-16 of *Figure 14*;

*Figure 17* is a perspective view of means to delineate a head zone to be irradiated;

*Figure 18* is a side elevation view of further modified intra-oral X-ray tube apparatus;

*Figure 19* is a top plan view on lines 19-19 of *Figure 18*;

10 *Figure 20* is an end view on lines 20-20 of *Figure 18*;

10

*Figure 21* is a view like *Figure 20*, with a shield and tongue suppressor attachment;

*Figure 22* is a side elevation showing still further modified intra-oral X-ray tube apparatus;

*Figure 23* is a section on lines 23-23 of *Figure 22*;

*Figures 24* and *25* are views like *Figure 11*, showing modified attachments, and

15 *Figure 26* is a view like *Figure 12*, showing another modified attachment.

15

Referring first to *Figure 1*, X-ray apparatus 10 includes a high voltage generator console 11 to which X-ray tube 12 is electrically connected, as via cable 13. A suitable adjustable support for the tube 12 includes upright post 14 carried by the console; an arm 15 adjustably attached at 16 to the post to rotate about a vertical axis; and a mount 17 for the tube apparatus and adjustably attached at 18 to the arm 15 to rotate or

20 swivel about a horizontal axis.

20

Extending the description to *Figure 2*, the tube means 12 includes a housing 19 containing the micro-focus X-ray tube 20 which produces an electron beam 21. A beam target 23 is carried by the tube means and is located axially rearwardly thereof (relative to the patient's head 22) to be inserted or received relatively rearwardly into the patient's mouth. The forward and rearward axis appears at 36. In the example shown, the

25 target 23 is carried by the rearward end portion of a rearwardly axially elongated tubular element 24

projecting into the patient's mouth. The cable 13 is attached to the housing at 26, and passes through an insulator 27 to the gun 20a. The inner conductor of the cable is at high potential while the outer cable sheath is at ground potential and is solidly connected to the tube housing. The tube anode is also at ground potential and only the electron gun 20a is at high potential, insulated by gas or oil inside the tube housing.

30 This provides the necessary electrically shock-proof mounting for intra-oral radiography.

30

An alternative ceiling mount for the tube 112 in *Figure 3* includes an upright post 114 affixed to or carried by the ceiling of a room. Elements 115-118 correspond to elements 15-18 in *Figure 1*.

The target 23 may consist of tungsten embedded in a copper shield 31, the latter having upper and lower rearwardly tapering surfaces 80 and 81 which define an angle  $\alpha$  therebetween. That angle subtends a zone

35 which encompasses the patient's upper and lower teeth (including root areas) indicated at 32 and 33, but not including the brain or sinus area, the latter as well as the throat being protected from radiation impingement.

In this regard, an X-ray film holder 34 is carried by the apparatus 12 to extend at the front of the patient's mouth, and to overlap his cheeks at opposite sides of the mouth. The film holder is also substantially subtended by the angle  $\alpha$ . Alternatively, the film may be held in place against the patient's face as by an

40 elastic strap wrapped around his head, or the strap may incorporate VELCRO (Registered Trade Mark)

holding means. The target and shield are carried by the anode envelope 35 which is in turn carried by the tubular element 24. The anode envelope material is a low X-ray absorption material such as beryllium, titanium or aluminium, and forms the window for radiation emission.

Extending the description to *Figure 4*, the tube anode 37 is shown axially rearwardly of the gun 20a. The

45 target 23, located axially rearwardly of the anode, has surfaces 23a and 23b angled rearwardly and

transversely (i.e. sidewardly) relative to the axis 36. Surfaces 23a and 23b are transversely symmetrical relative to axis 36, and taper axially forwardly, as shown, at angles  $\beta$  relative to an upright plane 39 normal to axis 36; angle  $\beta$  may for example be about 20°.

In accordance with an important aspect of the invention, means is provided to effect transverse shifting of

50 the radiation pattern produced in response to beam incidence on the target. Such means may comprise a

magnet supported to be shifted transversely to deflect the beam transversely relative to the target; for example, *Figure 4* shows the magnet 40 suitably supported at 41 by the tube at the right side of the axis 36, and rearwardly of the anode 37, the magnet acting to deflect the beam 21 transversely rightwardly so that it impinges on surface 23a. As a result, X-rays are produced to travel forwardly through the upper and lower

55 teeth at the right side of the patient's mouth and to the film in holder 34, such teeth indicated at 44. Actually,

radiation may extend transversely over the 180° angle indicated, and defined by the plane of surface 23a, and the shield does not interrupt such sideward radiation. See in this regard the shield openings 45 at opposite sides of the target, in *Figure 6*. Accordingly, the shield has sections 31a and 31b above and below the target.

Upon completion of exposure of the right side teeth 44 to X-radiation, the magnet 40 is transversely shifted

60 to the left side of axis 36, i.e. to a position as for example appears in *Figure 5*. In that position, suitably

supported at 41a by the tube, the magnet acts to deflect the beam 21 transversely leftwardly, so that it impinges on target left surface 23b. As a result, X-rays are produced to travel forwardly through the patient's upper and lower teeth to the left side of the mouth, and to the film in the holder 34, such teeth indicated at

65 surface 23b. The shield does not interrupt such sideward radiation, but does limit radiation in upper and

65

lower directions, to remain within the angle  $\alpha$  previously described.

Holders 41 and 41a may suitably releasably retain the magnet, as by detents. If desired, the magnet 40 may be rotatably carried to swing about axis 36 between the positions seen in Figures 4 and 5.

Figure 7 shows an alternative means to effect transverse shifting of the X-ray pattern with a fixed target, 5 seen in Figure 8. In this view, the tube 12 and supported target 170 are rotatable about axis 136 between the solid line and broken line target surface positions shown at 50 and 50a. For example, in Figure 1 the mount 17 may incorporate means to rotatably support the tube 12 to rotate about axis 136. A sidewardly projecting handle to rotate the tube 180° outside the mouth appears at 160. A tube position locking toggle appears at 161. In target position 50, the operation corresponds to that described in Figure 4; whereas in target position 10 50a, the operation corresponds to that described in connection with Figure 5. Envelope 135 and support element 124 correspond to items 35 and 24 in Figure 2. 10

Figure 8 shows the modified tungsten target 70 supported by shield 71, the latter projecting forwardly at 71a sidewardly of the target to block X-ray sideward travel and confine same to the region 72. The latter is related to teeth 144 at one side of the mouth as shown. Portions of the copper shield 71 not shown extend 15 above and below the target and forwardly as in Figure 6, so that a side opening is formed at only one side of the target. Target 70 and shield 71 rotate with the tube, as explained above. 15

Finally, it should be pointed out that since the X-ray intensity necessary for the required film density is proportional to the square of the focus-to-film distance, the radiation output of the X-ray source at 5 cm need be only 1/25 or 4% of that required at 25 cm with the conventional extra-oral X-ray tube distance.

20 The wide-angle radiation pattern of the present tube can expose a panoramic view of half the mouth including upper and lower teeth in one exposure, so that only two X-ray pictures are necessary instead of 12 with conventional extra-oral tubes. When this correction 1/6 is included in the 4% noted above, the total reduction in radiation amounts to only .66% of that required with conventional dental radiography for the same visual information. This is a very significant reduction in radiation dosage which is less than 1% of the 25 present radiation level for whole-mouth dental radiography. 25

Referring to Figure 9, the modified apparatus 100 includes an X-ray tube means 101, and a target 102 spaced from the tube to be received rearwardly into a patient's mouth. A tubular carrier element 103 for the target is attached to the tube means as at 104 and projects rearwardly. The target may be supported by a shield 105 similar to shield 71 described above. It is carried by the carrier tube 103 and projects forwardly at 30 105a sidewardly of the target to block X-ray sideward travel in the direction 106 and confine X-ray travel to the region designated at 107. The latter is related to teeth 108 at one side of the mouth, as shown. Portions of the shield extend above and below the target (as in Figure 7a) and forwardly of the target as at 105b, so that a side opening is formed at only one side of the target. The target and shield rotate with the carrier probe or tube 103, and a window 109 is formed in the latter to pass X-rays. With the 30° target oriented as shown, and 35 between upper and lower molars at one side of the mouth, the sidewardly directed wide angle X-ray beam at 107 traverses all the upper and lower teeth 110 at the opposite side of the mouth, a film 111 being located outside or inside the mouth and proximate teeth 110 for exposure to the X-radiation and recordation of tooth and gum images. Accordingly, only two exposures are needed to record images of all teeth, one exposure as illustrated, and an opposite side (mirror image) exposure with the target located between the molars at the 40 opposite side of the mouth and directing X-rays rightwardly. 40

Referring to Figures 10 and 11, the elements 100-105 and 109 remain as in Figure 9; however, additional and very important structure is provided, namely, X-ray shielding and tongue suppressor means carried by the apparatus to be received into the patient's mouth and characterised in that when the target is located at one side of the mouth to direct an X-ray beam toward teeth at the opposite side of the mouth the shield will 45 protect portions of the mouth from the X-ray beam and the patient's tongue will be suppressed relative to the X-ray beam. While such apparatus may take various forms, that form as illustrated by component 112 in Figures 10 and 11 is of unusual advantage. It includes a base 113 which is rearwardly lengthwise elongated and forms an elongated opening or semi-circular bore 114 sized to snugly receive the tube 103, i.e. with frictional or other (such as tongue and groove at 213) interfit resisting relative rotation of the component 112 50 and tube 103. Preferably, the component 112 has removable attachment to the tube 103, for ready replacement by another component for use with a different patient. Thus, component 112 may be dispensable, and provides a new, sterile hygienic cover for the tube 103 for each use. Tube 103 may consist of copper or Monel (Registered Trade Mark), and have a titanium window 214 to pass radiation. 50

The component 112 also typically includes arms projecting sidewardly from the C-shaped base 113 with 55 V-shaped relative configuration, the radiation passing between the arms. As illustrated, the lower arm 116 extends downwardly and sidewardly sufficiently to extent centrally over the patient's tongue 117 to forcibly suppress same out of the main path of the radiation beam, the vertical path of which may sweep an arc such as at 107a in Figure 11. Note the edge 116a of arm 116 over the centre of the tongue, with base 113 clenched between the patient's upper and lower molars 119 and 120 at one side of the mouth (the right side, as also 60 related to Figure 9). The upper arm 118 typically extends upwardly and sidewardly toward the root area of the upper molars 121 at the opposite side of the mouth, and in this regard, arm 116 typically extends toward the root area of molars 122. The two arms also function as shields to prevent X-ray travel outside the path or arc 107a, i.e. protecting the palate and below tongue areas of the head, containing sensitive gland, sinus and brain zones. The X-ray paths 107 and 107a may include the temporo-mandibular joint. 60

65 The component 112 may advantageously consist of plastic material (such as polyethylene) containing 65

X-ray shielding material, as for example barium particles dispersed throughout the plastic in as-moulded or formed condition. Other shield substances and component compositions may be utilized.

In the mode of use as illustrated in Figures 9 and 11, with a substantially longer source-to-image distance than is characteristic of Figure 4 use, the magnification, distortion and geometric unsharpness are all  
5 reduced to improve the overall resolution of the X-ray beam.

Figure 11 also illustrates the provision of upper and lower integral projections or tabs 125 and 126 on the component 112, to engage the outsides of the posterior molars as shown. They aid in positioning the component relative to the molars when the patient bites down onto the outer surfaces 127 and 128 of the component. Pockets are formed between the lengthwise extending tabs 125 and 126 and arms 116 and 118,  
10 to receive and locate the molars, during bite-down, firmly locating the arms 116 and 118.

Figures 12 and 13 show the provision of an additional X-ray filter 129 extending over the tube 103. Tubular filter 129 may consist of aluminium or other shielding material. The filter may form a window to register with window 109.

Figures 14-16 illustrate the use of an extra-oral source adapter removably carried by the tube 103. The  
15 adapter structure 130 typically projects sidewardly of the carrier tube 103 and target 102, and is located to pass an X-ray beam sidewardly from the target toward a patient's anatomy, and exteriorly thereof. For example the structure may be placed against the cheek area 131 adjacent the teeth, the X-ray film then being located inside the mouth in a conventional manner. The structure 130 may include a support cylinder 132 removably slipped onto or over the tube 103, and suitably secured to the X-ray tube housing, as at 133. The  
20 latter may include a bracket 134 which encompasses the housing 19 and may be clamped thereto as by tightening screw 135.

The structure 130 includes beam collimator means defined by plastic cylinder 136 and internal metallic tubular shield 137. These elements extend generally coaxially with respect to the axis 138 of the X-ray beam embraced by arc 140. Element 136 projects further from the cylinder 132 than element 137, and both tend to  
25 limit the beam to a narrow cone circumscribing the rectangular periapical X-ray film used in conventional extra-oral radiography.

Among the advantages of the above apparatus are the following:

1. Increased magnification of the tooth area facilitates diagnosis; for example, detection of pulp in the root area is made easier, and the results of grinding of teeth show up more clearly. Thus, the dentist can  
30 more accurately inform the patient of grinding and the deleterious results of same including possible injury to the jaw hinge joint. Splintering of teeth is also more easily detectable, and sinus areas can be X-rayed to show up more clearly.

2. The depression of the tongue prevents obscuration of the film.

3. The aluminium filter on the tubular carrier tends to even out the beam intensity over the film area,  
35 producing a better picture.

4. The side-to-side interior X-ray technique enabled by the invention facilitates rapid taking of full mouth X-rays, using only two exposures, which in turn facilitates accurate charting of teeth by the dentist. Also, the patient can be shown the full X-ray picture, and can easily see what dental work needs to be done, so that communication between dentist and patient is improved.

40 5. The invention used for panoramic radiographs removes need for conventional bite-wings and their holders inserted into the mouth, obviating discomfort and injury that can result from these items.

6. The probe itself (target and carrier) can be used in emergencies such as accidents wherein patients undergo severe facial injury, so as to secure pictures of the extent of that injury. Also, information highly useful for plastic surgery can be easily obtained.

45 7. Irradiation of sensitive areas of the brain, optic nerve, thalamus and thyroid glands is avoided.

8. Full X-ray data, obtainable through use of the invention, is easily obtained for use as best evidence in legal proceedings.

Finally, Figure 17 illustrates the provision of support operatively connected to the above-described X-ray tube means, together with other means carried by the support at a location to project toward the patient's  
50 head an image delineating an area within the main path of the X-ray beam. As illustrated, such other means typically includes a light source 200 carried by the support arm 201, the latter extending from a mount 202 attached to the X-ray tube housing 19. The light source 200 may be suitably shielded at 204.

Light refracting structure is located in the path of light transmitted from the source 200, such structure advantageously taking the form of a double prism 206 attached to the shield 204, for example, and extending  
55 in openly spaced confronting relation to the component 112. Light projected downwardly via iris 204a and in the prism, as rays 207 and 208 is reflected by prism face 209 as rays 207a and 208a, and an upper image 204b of the iris 204a in the shield may be formed between the rays 207a and 208a as for example on a patient's face. Similarly, light projected downwardly via the iris as rays 211 and 212 is reflected by prism face 210 as rays 211a and 212a and a lower image 204c of the iris may be formed between the rays 211a and 212a as on a  
60 patient's face. Images 204b and 204c delineate the upper and lower limits of a facial area in the main path 107 of the X-rays from the target. Accordingly, the technician will know precisely where to locate the X-ray film adjacent the patient's face.

Referring now to Figures 18-20, the illustrated X-ray tube means for providing an electron beam along axis 300 includes an X-ray tube 301 contained within housing 302. The tube anode appears at 303, and the  
65 housing is attached to the anode as via O-ring 304 and nut 305 threaded on the anode at 306 to retain the

housing bore portion 302a thereto.

A target for the beam is indicated at 310, and may consist of tungsten. Its surface 310a is angled to face forwardly and sidewardly, as shown, and it is supported by an electrically conductive part 311 located rearwardly thereof. Part 311 and the target are located within an elongated carrier 312 adapted to be received 5 in the patient's mouth. The carrier defines a tubular X-ray shield, and for that purpose the tubular carrier may consist of copper. Part 311 is in electrical contact with the carrier at 313 for grounding of the target; thus, the part may fill carrier bore 312a. Head 311a fits against the end of the carrier to accurately position the target, axially. The carrier is connected to the anode 303 at 299.

A ceramic element is provided to define an X-ray window carried by the carrier and positioned to 10 sidewardly laterally pass X-rays emanating from the target in response to electron beam impingement on the target.

In that form of the invention shown in Figures 18-20, the ceramic window 313 is located in a side-opening or cut-out 314 formed in tubular shield or carrier 312, and it may be peripherally brazed in position as shown at 315. The window is laterally arcuately curved to match the curvature of the tubular shield, and it has 15 longitudinally spaced, laterally extending edges at 313a and 313b, as well as circularly spaced, longitudinally extending edges 313c and 313d. Such edges or boundaries define the shape of the cone of X-radiation passed by the window. Edge 313b laterally overlaps the target, as shown in Figure 19. The use of a ceramic window is found to result in very clear, X-ray produced images of teeth, on film located as previously described. The window may be of uniform radial thickness.

Figure 21 shows the X-ray shielding and tongue suppressor means 320 (corresponding to that described 20 earlier at 112) carried by the shield 312, with a side opening 321 in lateral registration with window 313. Side opening 321 is formed between laterally diverging arms 322 having laterally diverging interior surfaces as shown. A keyway or other guide shoulders at 323 provide a longitudinal interfit between the carrier 312 and the base 324 of the attachable means 320 to assure proper lateral registration of opening 321 with the 25 ceramic window. The ceramic window is thus a cylindrical segment having rounded corners at 350.

Turning to Figures 22 and 23, the modified ceramic element 330 forms a complete cylinder and is held in coaxial end-to-end relation with the tubular shield or carrier 331, which may likewise consist of copper. For example, a thin metallic (nickel) sleeve 332 may extend closely about and position tubular portions of the shield 331 and ceramic element 330. In this case, the sleeve portion 332a overlapping the ceramic element 30 defines an X-ray shield and a boundary of the window to limit the X-ray cone at locus 333. Another and like 30 sleeve 334 fits over the opposite end portion of the ceramic element to limit the X-ray cone at 335. A metallic ring 336, as for example copper, fits within the sleeve 334 and is joined thereto in spaced relation to the ceramic element, and the electrically conducting support 337 for the target 338 is received within the ring 336 and the ceramic tube, as shown.

An auxiliary, semi-cylindrical X-ray shield 339 extends partly about ceramic element 330 and about the 35 sleeves 332 and 334 to establish an electrically conductive grounding path between the target, part 337, sleeves 334 and 332, carrier tube 331 and the anode 303. Shield 339 has longitudinal edges 339a and 339b which establish boundaries 340 and 341 for X-rays passing through the window. The cone angle between the boundaries 340 and 341 is typically about 45°, whereas the cone angle between boundaries 333 and 335 is 40 typically about 75°.

The shield 339 may consist of lead, and usable ceramic compositions for tube 330 and window 313 include the following examples, others being possible:

45	I		45
	beryllium oxide	about 90% by weight	
	silicon dioxide	about 7% by weight	
	impurities		
	(clays, magnesium etc.)	balance by weight	
50			50
	II		
	aluminium oxide	about 90% by weight	
55	silicon dioxide	about 7% by weight	55
	impurities (see above)	Balance by weight	

Referring to Figure 24, it shows a ceramic tubular element 430, like element 330 in Figure 22, onto which an element positioning, X-ray shielding, tongue suppressing means 420 is received. The means 420 60 corresponds to that described at 320 in Figure 21, excepting that the ears or tabs 421 are located out of alignment with the tubular element 430. Molars 422 and 423 are in alignment with the tube, and are received in pockets 424 formed by the means 420. Figure 25 is similar, excepting in this case, the tabs 421a on modified means 420a are sufficiently spaced from and at the outer side of the tube 430a that the latter is positioned at the inner sides of the molars 422a and 423a. Positioning of the tubes by the means 420 and 65 420a eliminates need for repetitive re-taking of radiographs, reducing or eliminating aggravations and

irritation of the patient.

In Figure 26 the tube positioning, X-ray shielding, tongue suppressing means 512 corresponds to means 112 of Figure 10; however, stem 513 is annularly flared at its end 513a to fit over the end 520 of the tube housing. As a result, a patient's mouth does not come into contact with the tube or its housing, and the stem 513 acts as a sterile cover for the tube and housing. Elements 518 and 525 correspond to elements 118 and 125 in Figure 10. 5

## CLAIMS

- 10 1. A dental X-ray apparatus comprising an electron gun operable to direct an electron beam along an axis, a target carrier extending from said gun along said axis and having a distal end shaped to be received in a patient's mouth, a target carried by said carrier at said distal end and inclined with respect to the beam axis, a tubular X-ray shield positioned about said target coaxial with the beam axis, and a ceramic X-ray window located in said shield adjacent the inclined forward face of the target to pass X-rays emanating from the 15 target sideways from the beam axis to an X-ray film positioned externally of the patient's mouth. 15
2. Apparatus according to claim 1, wherein the target carrier comprises a tubular member of X-ray opaque material projecting from the electron gun coaxially along the beam axis, and wherein the target is mounted in the distal end of the tubular carrier, said carrier having a slot formed therein adjacent the inclined forward face of the target and having an X-ray transmitting ceramic element located in said slot.
- 20 3. Apparatus according to claim 2, wherein the target carrier is of metal and the target is mounted in the distal end of the tube by means of an electrically conductive mount in electrical contact with the carrier. 20
4. Apparatus according to claim 2 or 3, wherein said ceramic element is brazed into said slot.
5. Apparatus according to claim 2, 3 or 4, wherein the ceramic element is curved on the same radius as the tubular carrier thereby to form a flush uninterrupted curved surface with said tube.
- 25 6. Apparatus according to claim 2, 3, 4 or 5, wherein the longitudinal edges of said ceramic element and said slot extend radially from the tube axis. 25
7. Apparatus according to claim 1, comprising a tubular target carrier of X-ray opaque material projecting from the electron gun coaxially along the beam axis, a tubular element of X-ray transmitting ceramic material coaxial with said tubular member at its distal end, the target being positioned internally 30 within said tubular ceramic element, and a sleeve member of X-ray opaque material fitting around said ceramic element, said sleeve member having a longitudinal slot or split therein exposing a section of the ceramic element to form an X-ray window adjacent the inclined forward face of the target. 30
8. Apparatus according to claim 7, comprising two further sleeves of X-ray opaque material positioned about said tubular ceramic element, said further sleeves being spaced from one another along the length of 35 the tubular ceramic element and serving to define the longitudinal limits of the X-ray window. 35
9. Apparatus according to claim 7 or 8, wherein the tubular target carrier is of metal and the target is mounted in the ceramic element by means of an electrically conductive mount, and an electrical connection is provided between said mount and the tubular target carrier.
10. Apparatus according to claim 9, wherein the electrical connection between said mount and said 40 carrier is provided by said sleeve or sleeves being of an electrically conductive, X-ray opaque material. 40
11. Apparatus according to claim 10, wherein the first-mentioned sleeve defining the lateral edges of the X-ray window is of lead.
12. Apparatus according to claim 10, as dependent on claims 8 and 9, wherein said further sleeves are of nickel.
- 45 13. Apparatus according to any one of claims 2-12, wherein the tubular target carrier is of copper. 45
14. Apparatus according to any one of the preceding claims, wherein the target carrier additionally mounts a tongue depressing means and X-ray shield which, when the target carrier is positioned in the mouth, serve to depress the patient's tongue substantially out of the path of radiation passing through the X-ray window and to shield the roof of the patient's mouth from said radiation.
- 50 15. Apparatus according to claim 14, wherein the tongue depressing means and shield are detachably mounted on said target carrier. 50
16. Apparatus according to claim 15, wherein the target carrier is tubular and the tongue depressing means and shield comprise a sleeve of X-ray opaque material slidably receivable on said carrier and having a longitudinal slot alignable with the ceramic X-ray window to permit the radiation to pass from the window 55 through said sleeve, said sleeve further having two integrally formed arms of X-ray opaque material diverging therefrom in substantially V-form on opposite sides of said slot, the lower of said arms serving, in use, to depress the patient's tongue and the other serving to shield the roof of the patient's mouth.
17. Apparatus according to claim 16, wherein said sleeve and integrally formed arms are of plastics material containing an X-ray opaque substance.
- 60 18. Apparatus according to claim 17, wherein said X-ray opaque substance is barium. 60
19. Apparatus according to claim 16, 17 or 18, wherein the sleeve forming part of the tongue depressing means and shield extends the length of the carrier and has a terminal flange embracing the end face of the X-ray gun to prevent contact with the mouth of the patient by said gun.
20. Apparatus according to any one of claims 16-19, wherein the external surface of said sleeve, forming 65 part of the tongue depressing means and shield, is provided with one or more tooth locating abutments, 65

which abutment(s), when the target carrier with said sleeve thereon, is inverted into the patient's mouth between the molars on one side of the mouth, is or are engaged by one or more molars, thereby to locate the target carrier accurately in the patient's mouth.

21. Apparatus according to any one of the preceding claims, including an X-ray film support positioned 5 to hold an X-ray film in the path of the radiation passing through the ceramic X-ray window but externally of the patient's face. 5

22. Apparatus according to any one of the preceding claims, including means selectively operable to rotate the target, and the tubular shield comprising the ceramic X-ray window, at will through 180°.

23. Apparatus according to claim 1, substantially as hereinbefore described with reference to Figures 10 18-26 of the accompanying drawings. 10