

EQUIPMENT CALIBRATION WITH A MICROPROCESSOR CONNECTED
TO A TIME-SHARING SYSTEM.

G. FONTAINE, L. GUGLIELMI, J.J. JAEGER and S. SZAFRAN.

(Laboratoire de Physique Corpusculaire, Collège de France, PARIS).

ABSTRACT

In H.E.P., it is common practice to test and calibrate equipment at different stages (design, construction checks, setting up and running periods) with a dedicated mini or micro-computer (such as CERN CAVIAR).

An alternative solution has been developed in which such tasks are split between a microprocessor (Motorola 6800), and a host computer; this allows an easy and cheap multiplication of independent testing set-ups. The local processor is limited to CAMAC data acquisition, histogramming and simple processing, but its computing power is enhanced by a connection to a host time-sharing system via a MUMM multiplexor described in a separate paper. It is thus possible to perform sophisticated computations (fits etc...) and to use the host disk space to store calibration results for later use.

In spite of the use of assembly language, a software structure has been devised to ease the constitution of an application program. This is achieved by the interplay of three levels of facilities: macro-instructions, library of subroutines, and Patchy controlled pieces of programs. A comprehensive collection of these is kept in the form of PAM files on the host computer.

This system has been used to test calorimeter modules for the UA 1 experiment.

1. WORKING METHODS

1.1 Introduction.

Present-day equipment used in High Energy Physics (H.E.P.) experiments requires constant supervision of its behaviour or of the quality of the collected data. This need can be related either to its intrinsic complexity, its large number or the "high" degree of precision aimed at.

These problems, relatively new by their scale, can be solved by the use of digital computers integrated in the experimental set up and running in real-time in parallel with data acquisition. This task can be carried out by a dedicated mini or by a distributed set of microprocessors (μ . P.). This last solution has the advantage of allowing independent processing of distinct parts of the apparatus. In addition, the μ . P. developed for this scheme can be used on the electronics work-bench in the early stages of the experiment (design and construction) for evaluation, testing and checking detector components or sub-assemblies. Their use as an investigation tool is becoming almost as common as that of oscilloscopes and allows measurements in conditions closer to the final ones (using integrating ADC, etc...).

1.2 General operating conditions.

Since μ . P.s are relatively new devices, one has to think about different ways of using them in H E P, where their applications can range from data reduction or decision making to equipment control and monitoring, all of these requiring different types of pro-

cessors. Even by restricting the goal to the last points, there is still a broad choice open concerning processor configuration and operating conditions :

- A μ . P. can be used as a stand-alone computer¹⁾ with a large memory and many peripherals : terminal (VDU), line printer, floppy or even fixed disk. It is then compulsory to have a high level language and a good resident operating system available. This situation is not far from that of a mini and in these conditions, the number of processors is limited to a few units.

- On the other hand, a processor can be considered as a black box, performing simple but repetitive operations with EPROM firmware requiring no classical peripheral and dealing only with interfaces to the experiment. This is above all the new domain opened by μ . P.s, since they allow drastic cuts on the cost per unit, and hence an important multiplication of the number of units. The ideal for a μ . P. is then that everybody forgets about its presence as in a Silent 745 terminal or in a 4032 H.V. supply.

1.3 Particularities of our system.

This automaton approach has been our starting point (see Appendix A for a hardware description), and since a H.E.P. experiment is not pure routine work we had to allow a progressive interaction with the processor :

- It has to be able, once started, to run without any peripheral.

- It includes a RS 232 C serial port interface, where a VDU can be plugged in :
 - . to start the processor, or stop it and get back some status or collected information
 - . in case of trouble, to fix the bug with the help of a standard monitor.

- If the trouble is severe, or at development stage, the VDU is replaced by a MUMM multiplexor²⁾ which allows a connection to a host computer which can be one of the experiment on-line computer, or any remote large-size machine with a time sharing network. The automaton is then given all the possibilities of a complete stand-alone system :

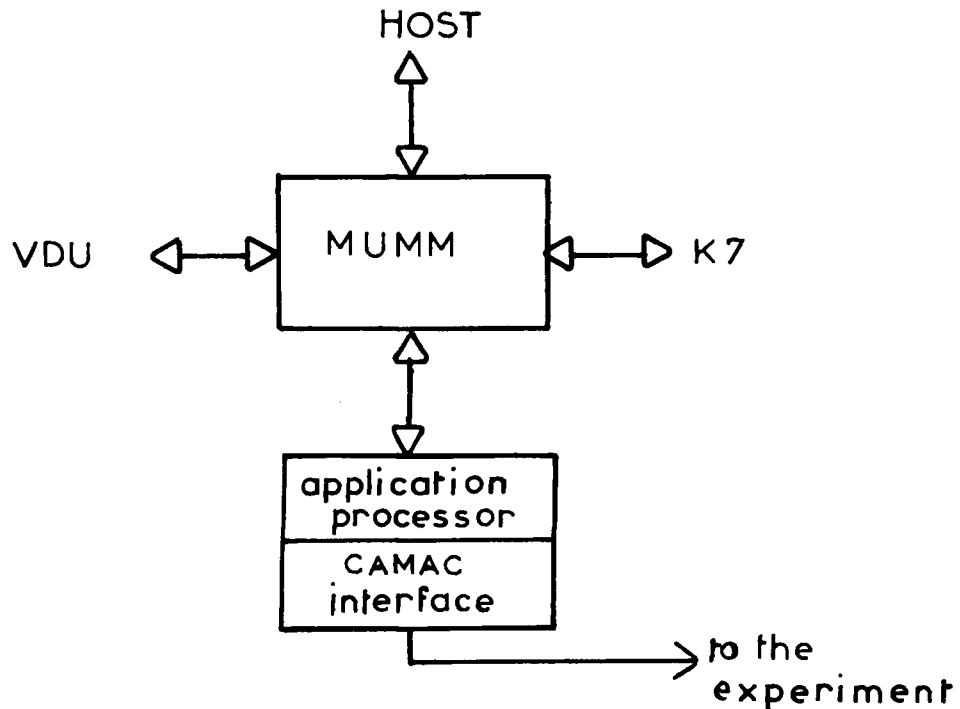

After some experience in this connected configuration, it became obvious that this connection was able to provide much more than occasional support. By enabling easy transfers of information in both directions between the host and the application μ . P., it allows splitting of data processing between both machines, and hence to move a large fraction of the workload to the large machine with which all physicists are familiar and where a lot of experience and utilities are available. The microprocessor task is then limited to CAMAC data acquisition, histogramming and simple processing, the results of which are sent to the host where more sophisticated computations (fits, etc...) can be performed and results kept on disk for later use. Since the host can take complete control of the μ . P., the latter can be considered as an "intelligent" CAMAC interface of the time-sharing network.

2. APPLICATION SOFTWARE GENERAL DESCRIPTION.

2.1 Software structure.

Any typical μ . P. application can be divided into three stages :

- Interactive initialisation phase,
- Data acquisition and processing phase,
- Interactive termination phase.

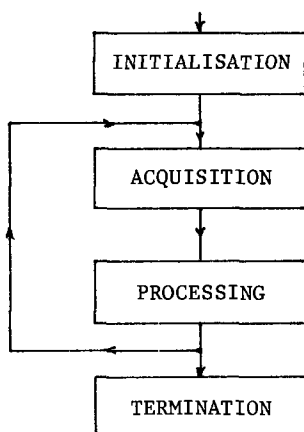

Data acquisition is done through the CAMAC interface and local processing is mainly histogramming, computation of mean values and standard deviations, or any simple data reduction technique which limits the amount of information to be kept in memory until the final phase. All these operations are usually application-dependent and run without external intervention.

Each of the initialisation and termination phases can be split in two parts : one specific to an application, the other being more general and consisting of histograms booking, editing, display or transfer to the host for postprocessing. All of these operations require a strong interaction with the user, either directly from his VDU or indirectly through the host running program.

Despite the lack of local resources (no mass storage, no resident assembler on the μ . P.) and the use of assembly language (no cross compiler yet installed), the users are helped in their task of writing specific application software by a set of facilities either resident or available through the host connection. Our "system" therefore consists of two parts :

- a target-resident interactive monitor,
- a package of host-based facilities.

2.2 The target-resident interactive monitor.

This monitor processes alphanumeric commands obtained from a RS 232 C serial port, according to a unique syntax :

Keyword, P_1, P_2, \dots, P_n .

where the parameters P_i , separated by a comma, can be either numbers (decimal, octal or hexadecimal) or alphanumeric strings, according to the keyword.

The standard available commands are listed in appendix B and concern :

- Histogram booking and display,
- CAMAC interface,
- Some debugging facilities.

Command decoding is readily accessible from an application program. Hence new interactive commands following the same syntax rules can be added without effort.

The commands can be supplied one by one from the user VDU, or for a long sequence they can be sent by a host utility taking them from a disk "exec file".

The monitor makes use of three resident subroutine libraries (in EPROM) which are also accessible from the user written software. These routines are classed under the following library headings : histogram, CAMAC, and general purpose, of which an almost complete list can be found in appendix C.

2.3 Host based facilities.

The first of these facilities is, of course, the cross software run on the host for source-to-binary program translation³⁾. Connected to it are the use of disk space, line printers, text editor, down-line loader, etc... as described elsewhere²⁾.

In addition a large library of Macro-instructions has been developed to ease the coding of programs written in assembly language. This library, kept as a separate disk file on the host, contains macros for calling and passing arguments to the resident library routines. It also contains general purpose macros such as multi-byte manipulation or arithmetics, or character string handling, etc...

Numerous sections of source code that could be of some general interest for an application program are also kept on the host disk. They include complete subroutines or just open instruction sequences and are maintained, by the use of the CERN PATCHY⁴⁾ source code management program, in the form of a PAM file called MAINPAM. This file contains all the code usefull to link a user program with the resident monitor, and a collection of application-dependent code, such as for instance routines to use some specific CAMAC devices.

The use of these host-based facilities extensively reduces the amount of time needed to write any application program for our microprocessor.

3. A SPECIFIC TEST BENCH APPLICATION.

As an illustration, we describe one of the first applications of our μ . P. system. The aim was to study some design parameters' action on the attenuation length of electromagnetic calorimeters built for the forward detector of the UA 1 experiment.

In the test set-up shown in fig. 1, a lead scintillator sandwich module of the calori-

meter is placed in between 5 pairs of trigger counters in coincidence which give a measurement of the position of incoming cosmic ray muons. The calorimeter PM signal amplitude and the triggering pattern are measured via CAMAC, and the influence on the position dependence of the calorimeter output signal can be studied as a function of various parameters such as : scintillating medium quality, surface polishing, wrapping material and stack pressure.

The μ . P. program task was to perform CAMAC acquisition, to compute mean values and standard deviations, and to accumulate the collected signals in five histograms, one for each possible position of the incident muon. Due to flux and solid angle limitations, only a single run could be performed overnight to provide statistics of about 5 000 entries per location.

Every morning, a connection to the host (a time sharing CDC Cyber 172 of the CCPN in Paris) was established via a MUMM multiplexor²⁾ and the content of the five histograms were transmitted to the large machine for a detailed analysis which included fits by a scaled Poisson distribution. This would not have been possible to do on the μ . P. itself and allowed an absolute determination of the mean number of produced photo electrons on the PM photo cathode and a measurement of the attenuation length. The results were saved on disk and sent back to the VDU as shown in fig. 2 which displays a typical histogram with a super imposed fit result. The user was thus enabled to interpret the data and take decisions about the following runs.

The tests took about three weeks to be completed. Considering the computer equipment of our laboratory, it would have been impossible to freeze one of our mini-computers for such a long time. For this application, the user had to write 350 bytes of specific code which were added to the 4 K of the monitor firmware, and 1.5 K byte of RAM were used to store variables and 6 histograms of 100 bins each.

4. FUTURE AND CONCLUSION.

The UA 1 experiment is now being set up and will soon be in operation. The on-line computer complex includes a NORD 100 machine devoted to monitoring, control and calibration. But since it can service only one user at a time, and since the detector is made of many independant parts built by eleven different institutes, it is useful to also have some kind of possible local control. This is achieved as shown in fig. 3 by the use of REMUS Data Routers placed just below the REMUS Data Buffers which allow a parallel reading and a "fast clear" of the CAMAC Crates. The RDR allow to spy the data flowing in the main acquisition path and to store them in a separate buffer where they can be read by the microprocessor via a normal CAMAC Branch, a Crate Controller and a REMUS Read Write Branch Driver.⁵⁾

General NORD 100 control functions will include :

- Power supplies and data channels monitoring,
- Electronics calibration by the use of programmable test-pulse generations,
- Physics calibration by the use of excitations such as muons, U.V. light or X ray sources (mapping will be done only during shut-down periods).

Some of these will also be available on the local microprocessors, either to decrease the ND 100 load, to escape the excitement around it, or to be able to make fully independent tests in any occasions such as initial starting up. As shown in fig. 3, the interconnections between the possible hosts are dense enough to provide a real choice, and they allow working in the same environment either in C.E.R.N. or in Paris.

REFERENCES

- 1) S. CITTOLIN and B.G. TAYLOR, "Caviar : interactive microcomputer control and monitoring of multi-crate CAMAC systems", CERN-EP report, March 1978.
- 2) G. FONTAINE, L. GUGLIELMI, J.J. JAEGER and S. SZAFRAN, "M.U.M.M. a Micro-controlled Universal Message Multiplexor". Contributed paper to the Topical Conference on the Application of Microprocessors to High-Energy Physics Experiments, CERN, 4-6 May 1981.
- 3) C. ADAMS and I. WILLERS, "CERN Motorola 6800 Microprocessor Support", CERN-DD/US/48, June 1978.
- 4) H. KLEIN and J. ZOLL, "Patchy Reference Manual", CERN. See also simplified guide Ref. CERN-DD/US/60.
- 5) M. DEMOULIN, private communication.
- 6) "Notice d'utilisation de la carte multifonction CMF 6800 C/E", Ets GROS SA, 5 rue Pascal, F-94800 Villejuif.

* * *

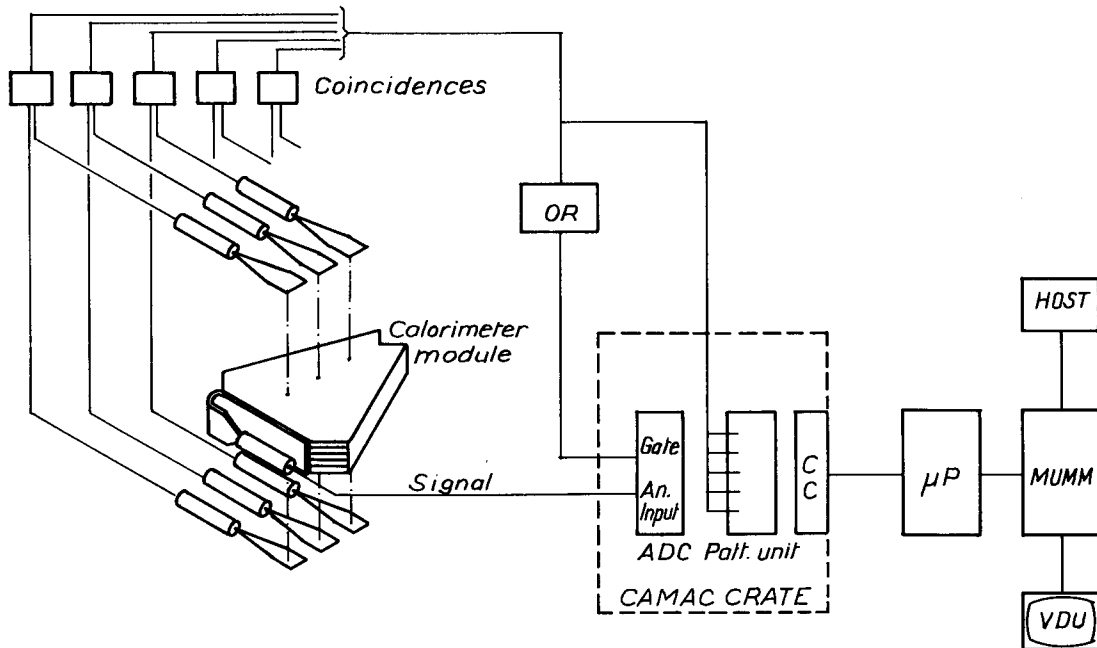

Fig. 1 Typical test-bench application set-up

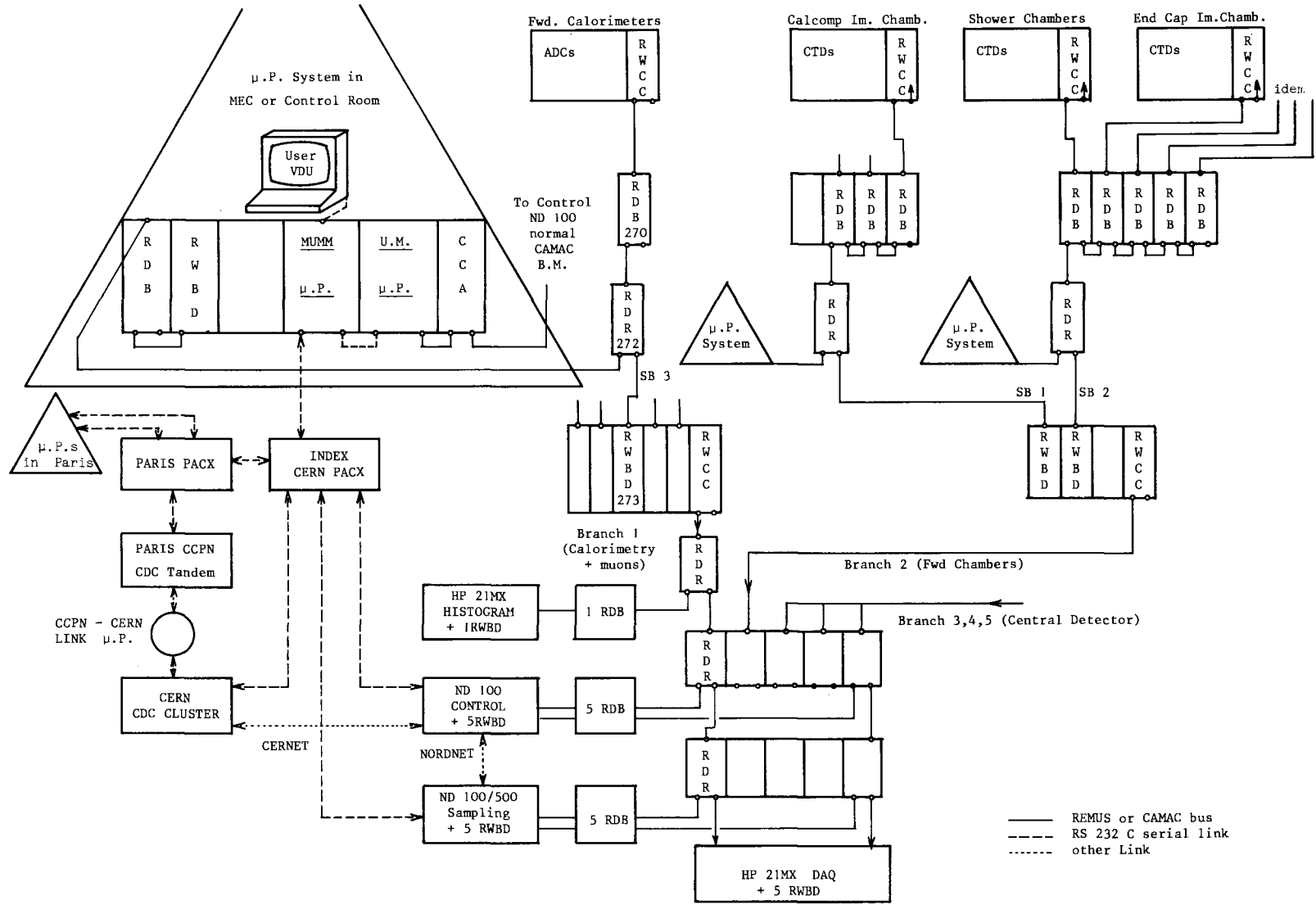

Fig. 3 Control microprocessors implantation in UA1 experiment

APPENDIX A : Hardware description.

The μ . P. is a Motorola 6800 housed in a 8/25 CAMAC module mechanics. It uses the crate power supplies, has no direct connection to the dataway but acts as a full branch controller (7 crates, 24 bits) with a front panel connector.

The internal cards are Exorciser compatible with 4 slots available for :

- a CPU card⁶⁾ with 4 Kbytes of RAM, up to 16 K of EPROM, 1 real time clock, 1 ACIA and 2 PIA used for CNAF control.
- Two CAMAC interface cards, identical for maintenance reasons with those of CERN CAVIAR¹⁾. They use 2 additional PIA (3 bytes) for data I/O.
- An optional RAM extension depending on the application and whose size can presently be of 4 or 16 K bytes.

APPENDIX B : Resident Monitor commands.

- Histogramming.

HINI , NHMAX , SPACE
HBK1 , NHISTO , NBIN , LOWEDGE , WIDTH , TITLE
HCLR , NHISTO
HDEL , NHISTO
HPRT , NHISTO
HPLO , NHISTO , FIRST , LAST
HOUT , NHISTO , FIRST , LAST
HSEN , NHISTO

- CAMAC.

CCINIT
CBZ
CDREG , NAME , C , N , A
.....

- Other

PR , ADDRESS , NBYTES , STEP
PRD , ADDRESS , NBYTES
MOV , EMETEUR , RECEPTEUR , NBYTES
FIL , ADDRESS , NWORDS , VALUE
HELP
QUIT (returns to Minibug)
USER , ON
USER , OFF

- The user program is supposed to provide its own commands, at least the "RUN" command !

APPENDIX C : List of the Resident Library Routines.

- Histogram

HINI , HBK1 , HCLR , HDEL , HFIL , HPRT , HPLO , HOUT , HSEN , HPAK , HSTAT

- CAMAC

CCINIT , CBZ , CDREG , CSSA , CSMAD , CSUBR

- General purpose

- . I/O : GETNB , GETSTR , HXDEC , OUTC , OUTND , OUTN, ...
- . Arithmetics : MUL10 , MULT , DIV , DIV32 , ...
- . Others : RMOVE , UZERO , UFILL , WCOMP, ...