

(21) Application No 8324733

(22) Date of filing 26 Mar 1981
Date lodged 15 Sep 1983

(30) Priority data

(31) 135026 (32) 28 Mar 1980 (33) US

(60) Derived from application No. 8109591 under section 15(4) of the Patents Act 1977.

(51) INT CL³
B01L 5/00 G01N 33/24

(52) Domestic classification
G1B CC CE
U1S 1252 G1B

(56) Documents cited
GB 0585322

(58) Field of search
G1B

(71) Applicants
Chevron Research Company (USA-Delaware)
525 Market Street, San Francisco, California 94105, United States of America

(72) Inventors
Gerard J. Demaison
Issac R. Kaplan

(74) Agent and/or Address for Service
Haseltine Lake & Co, Hazlitt House, 28 Southampton Buildings, Chancery Lane, London, WC2A 1AT

(54) Apparatus for use in predicting hydrocarbon potential of an earth formation underlying a body of water

(57) In a relatively quick, convenient and highly accurate technique for the determination of a carbonaceous gas, normally methane, contained in water samples collected at depth from a body of water overlying an earth formation to predict the hydrocarbon-containing potential of the earth formation, carbonaceous gaseous constituents liberated from the water are carried via an air stream to flow into and through an isotope trapping network where collection in microlitre amounts occurs. The isotope capture apparatus comprises a box-like structure formed from a series of panel members 50, 52 etc, front panel member 50 intersecting the bottom panel member near the centre of the latter and carrying interconnected gas trapping and stripping sections 35 to 40, the structure also comprising a detachable lid 54 connectable by means 56, 57 etc., for protection of sections 35 to 40.

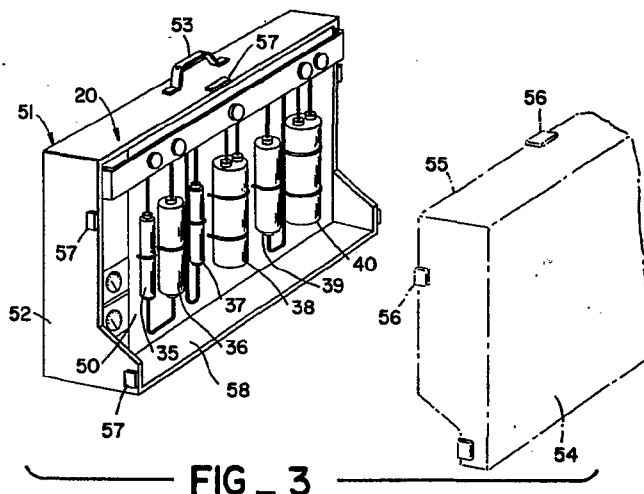

1/4

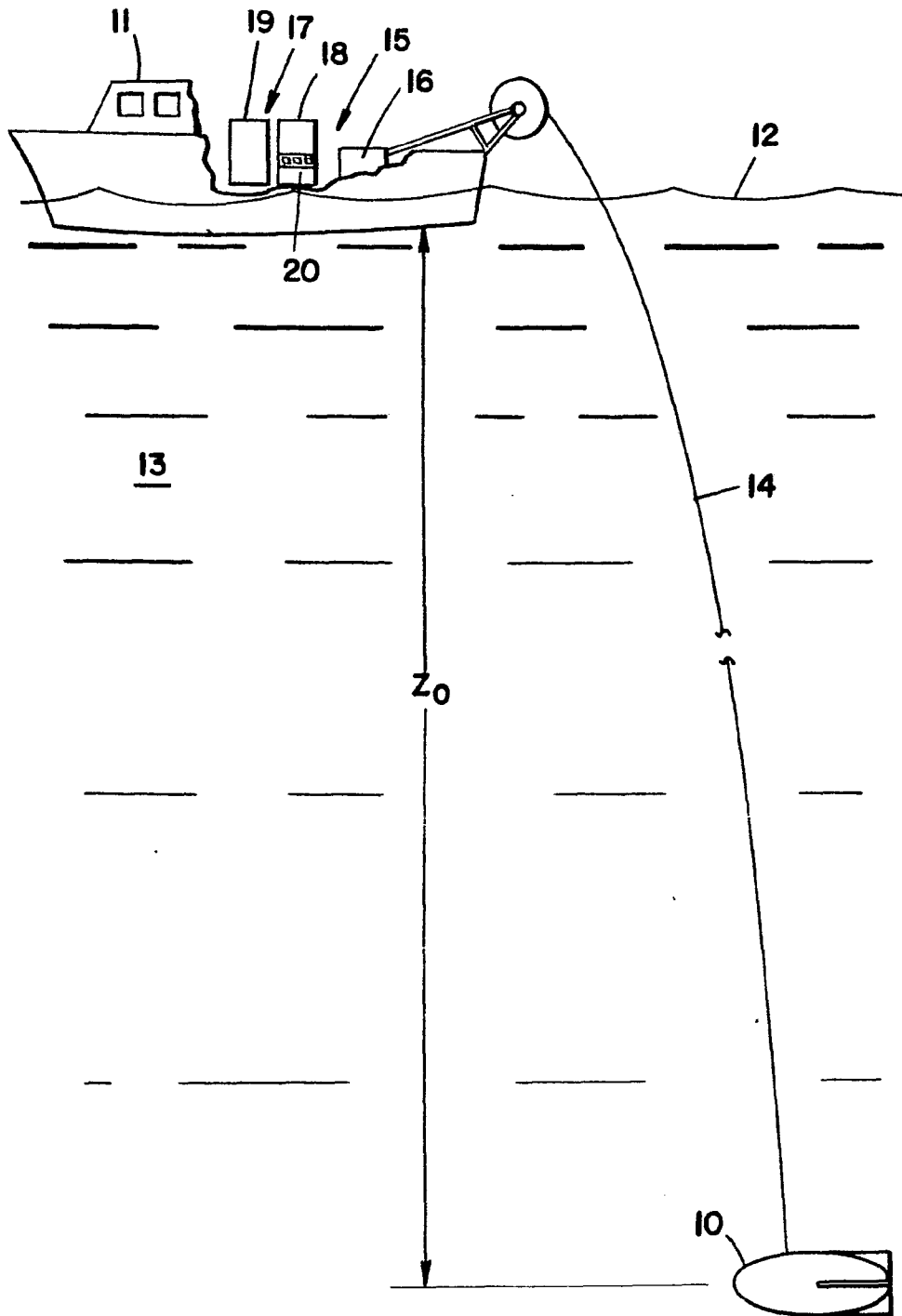

FIG _ 1

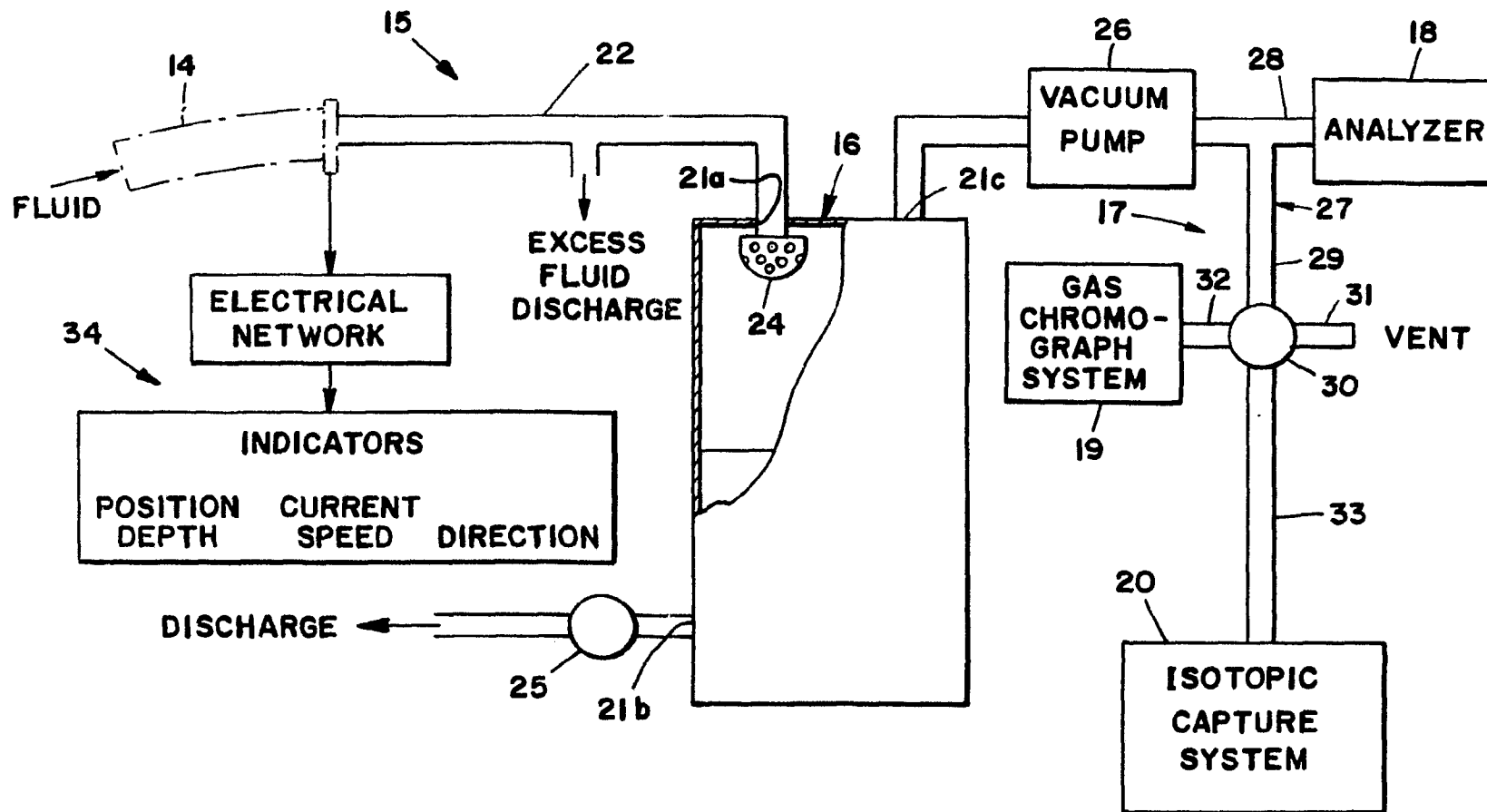

FIG - 2

2137339

47

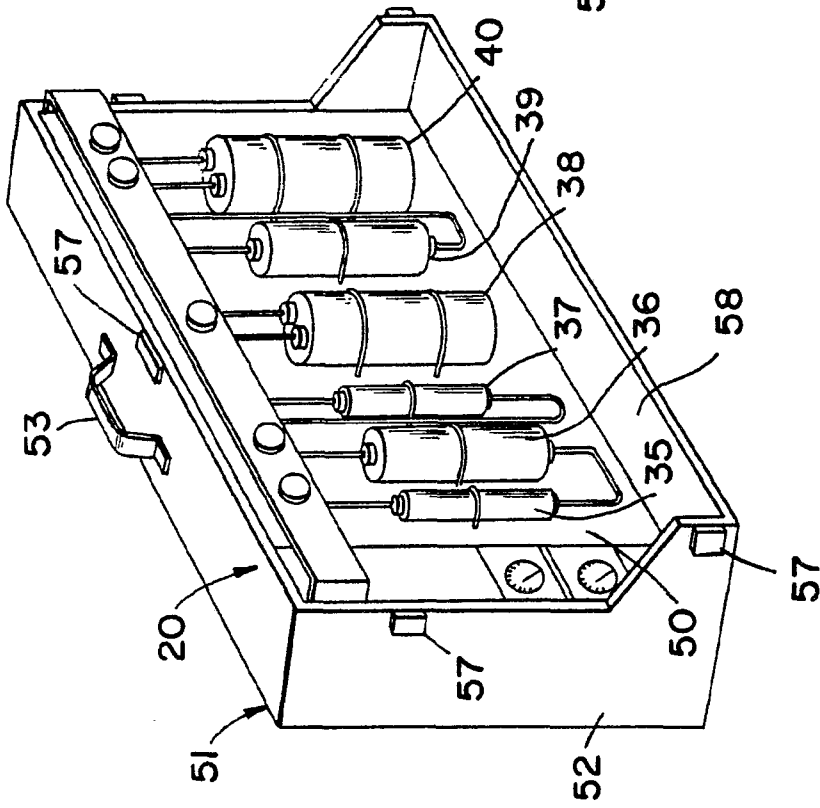

FIG - 3

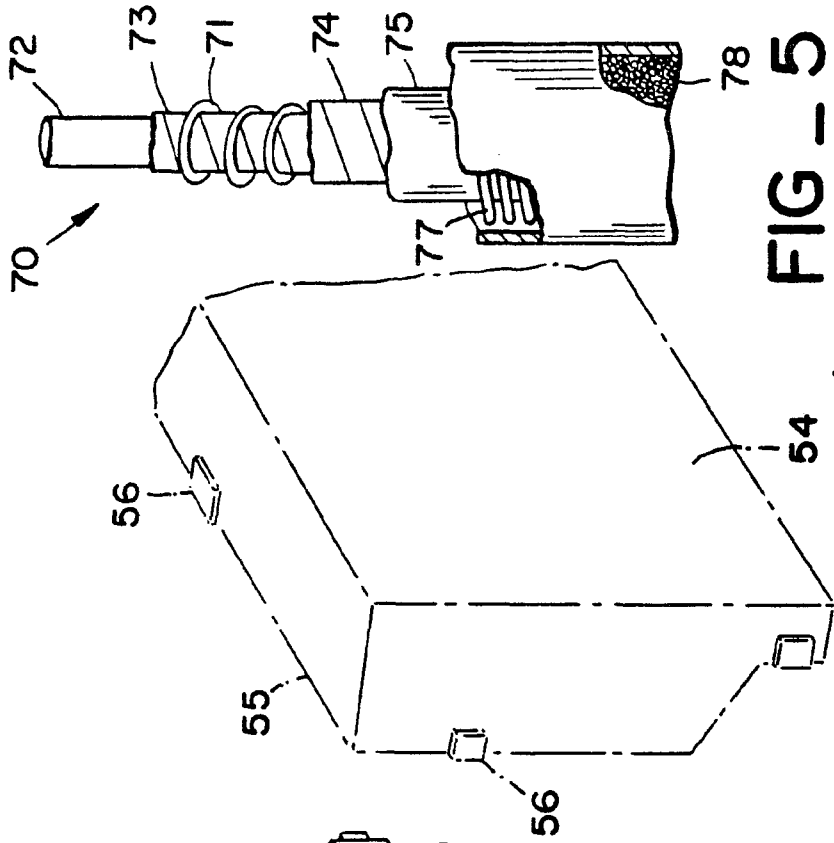

FIG - 5

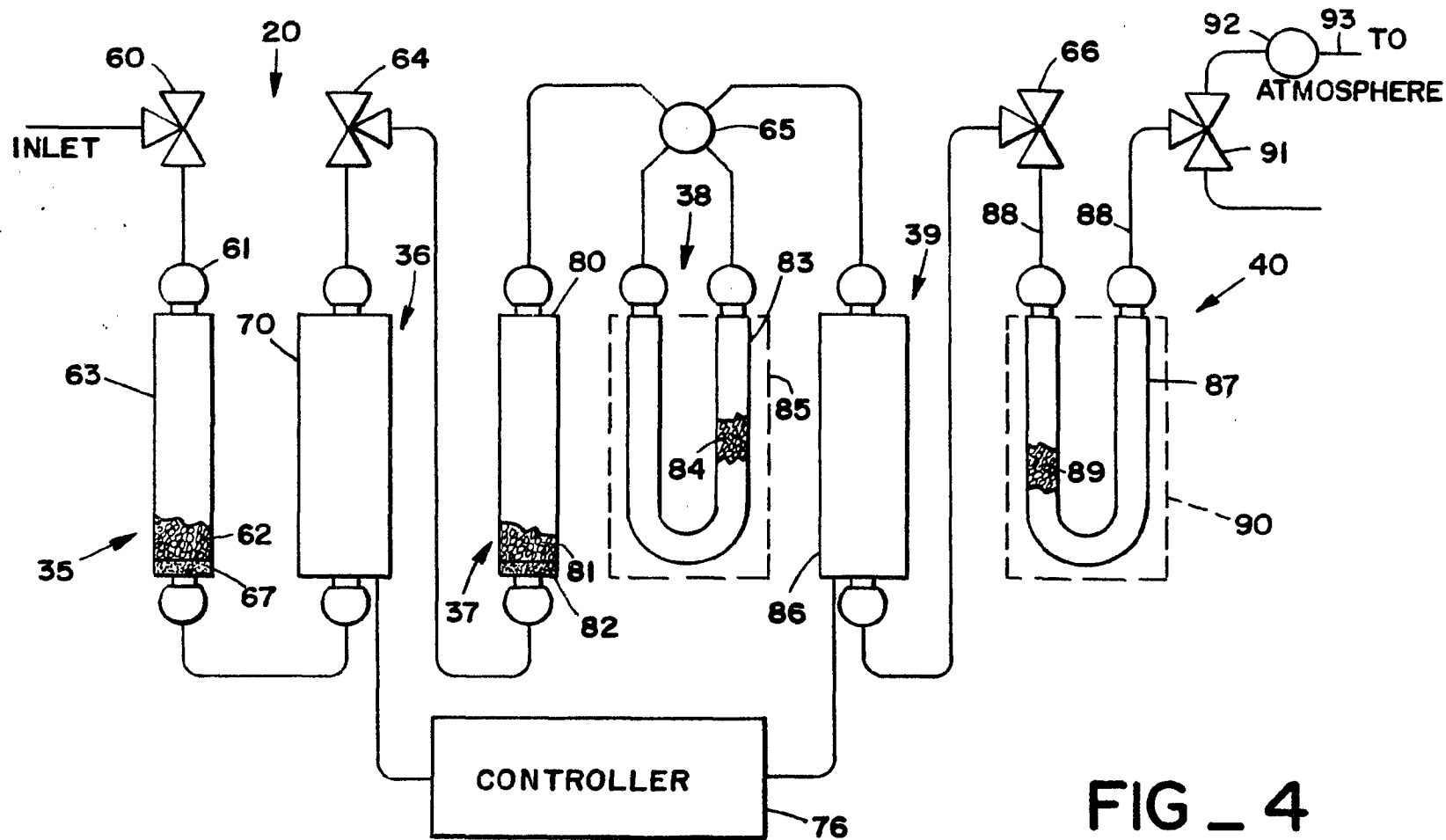

FIG. 4

7/77

SPECIFICATION

Apparatus for use in predicting hydrocarbon potential of an earth formation underlying a body of water

5 This invention relates to an apparatus for use in providing isotopic chemical analysis of carbonaceous fluids from a hydrocarbon pool or other source of organic matter associated with an earth formation underlying a body of water, whereby indications of their biogenic and/or thermogenic origin can be accurately forecasted.

10 While marine exploration systems are presently available for continuously sampling water seeps so as to analyze for presence of carbonaceous fluids such as methane, none have the capability of providing a compositional parameter that is uniquely diagnostic of seep origin, and hence allowing the user/operator to distinguish the biogenically derived sample from a sample associated with a thermogenic source. The reason for this is that other interpretative tests were thought to be sufficient from a cost/result standpoint. Also, the lengthy and complexed nature of the steps involved in collecting, isolating and tagging sufficient amounts of the samples for such analysis were thought to be beyond the capability of present on-site collection and analytical systems.

20 In accordance with the present invention, a quick, convenient and highly accurate technique for the acquisition of sufficient amounts of one or more carbonaceous constituents dissolved in seep water is provided. Thus indications of the carbon isotopic character in the collected samples and their biogenically-and/or thermogenically-derived origin can be easily and surprisingly accurately determined.

25 According to the invention, there is provided portable isotopic capture apparatus suitable for use in a method of on-site collection and examination of small concentrations of a carbonaceous gas dissolved in a body of water under there is an earth formation so as to predict hydrocarbon potential of the earth formation underlying said body of water, said formation being a source of said carbonaceous gas. Such a method comprises:

- 30 (i) at a known geographic location continuously sampling said water at a selected flow rate and at a selected depth;
- (ii) continuously vacuum separating said water into liquid and gas phases;
- 35 (iii) quantitatively separating a selected carbonaceous gas from interfering gas species in the presence of an air carrier vented to atmosphere at a known flow rate and;
- 40 (iv) quantitatively oxidizing said selected gas and then cryogenically trapping an oxidation product thereof in the presence of said air carrier so as to provide for accurate isotopic examination.

The foregoing method forms the subject of our copending Application No. 8 109 591 (Serial No. 2 074 726).

The portable isotopic capture apparatus of the invention comprises:
a series of panel members, including front, top, and bottom panel members mounted together to form a

box-like structure including a storage zone interior of said panel members, said front panel member intersecting said bottom panel member near a mid-portion thereof, and being fitted with a series of interconnected trapping and stripping stations for performing selected capture of a carbonaceous gas at an on-site location such as aboard a vessel at the surface of a body of water; and

70 a series of disconnectable connectable attaching means mounted adjacent to said trapping and stripping stations on said panel members, whereby a separate covering lid having extending top and side wall members of a reverse orientation with respect to those of said associated panel members, can be attached, so that said trapping and stripping stations can be protected from breakage during a transport.

The present invention provides for the acquisition of highly accurate data related to the isotopic chemistry — and the biogenic and/or thermogenic origin — of extremely small concentrations of carbonaceous gases and oils, say 100 to 1000 microliter per litre of the sea water, being constantly collected at depth.

85 Dissolved carbonaceous fluids including natural gases and oils are collectable in sufficient amounts utilizing vacuum separation and selective capture of natural gases utilizing an air carrier mixture. The sequence of steps includes: The fluids are first separated from the water collected at depth; then the methane present is quantitatively converted to carbon dioxide in the presence of a continuous air carrier vented to the atmosphere. Basis of later analysis is the isotopic composition of the ¹⁴C or ¹³C of the collected sample. Further, since the normalized variation of ¹³C to ¹²C (i.e., the delta ¹³C measurement) requires less amounts of methane to be collected, such analytical method is preferred. The delta ¹³C measurement is defined in *Petroleum Formation and Occurrence*, B. P. Tissot, D. H. Welte, Springer-Verlag, N.Y., (1978) at p. 88 as:

$$^{13}\text{C}^0_{/00} = \frac{(^{13}\text{C}/^{12}\text{C}) \text{ sample} - (^{13}\text{C}/^{12}\text{C}) \text{ standard}}{(^{13}\text{C}/^{12}\text{C}) \text{ standard}} \times 1000.$$

In more detail, sea water is first collected via an electro-hydraulic cable, at depth by a drone trailing from a sea-going vessel, the water being pumped at a substantially constant flow rate in a range from about 3 to 7 litres/minute up to a vacuum chamber aboard the vessel where the water is broken into droplets under a slight vacuum (27-28 inches of mercury) and the carbonaceous gaseous constituents, liberated. These constituents are carried via an air stream to a continuous hydrocarbon flame monitor where, if the flame monitor response is positive, more complexed analytical equipment is brought into play; e.g., a multi-port valve can be energized so as to allow the dissolved gases to be analyzed chromatographically. Or still another of the ports of the valve can be activated to allow the same constituents to flow into and through an isotopic trapping network where collection in microliter amounts occurs. Within the isotopic network, use is made of the flowing air stream (flow rate being preferably about 30 milliliters

per minute in a range of 20-120 milliliters per minute). Gases of interest pass, in seriate, from station-to-station: Methane is isolated (by removing all interfering species), and finally converted to carbon dioxide (in a catalytically-aided oxidation reaction) and cryogenically trapped in a U-shaped trapping chamber. Next, the ends of the trapping chamber are heated and collapsed, sealing them from the atmosphere.

After being transported to a mass spectrometer, the chamber is re-opened so that isotopic analysis can occur. Using the latter results (along with geographic address data) allows for accurate biogeographically- and thermogenically-associated predictions to be made, based on the delta ¹³C values of each collected sample as a function of location.

For a better understanding of the invention and to show how the same may be carried into effect, reference will now be made, by way of example, to the accompanying drawings in which:

Fig. 1 illustrates operation of the present invention, utilizing a vessel positioned on a body of water overlying an earth formation that collects and analyzes, continuously, samples of water at depth;

FIG. 2 is a schematic diagram of collection and analytical operations attendant on-site collection of water samples by the vessel of FIG. 1; and

FIGS. 3-5 are detailed drawings of an isotopic capture network of the associated on-site collection and analytical operations of FIG. 2.

Referring to Fig. 1, a drone 10 is positioned at a depth Z_0 below a vessel 11 floating at the surface 12 of the body of water 13. Within the drone 10, is a pump (not shown). The purpose of the pump is to draw water samples into the interior of the drone 10 and pump them up cable (via electrohydraulic cable 14) to a diagnostic system 15 aboard the vessel 11.

In addition to pumping equipment, the drone 10 is fitted with various oceanographic devices, including a depth sensor; a current monitor is also provided that includes a bottom-oriented sonar device in combination with an electromagnetic sensor for measuring the speed and direction of the ocean currents relative to the bottom. Signals from these devices pass via conductors in the side walls of the cable 14 so as to provide annotation (both visual and on tape), associated with geographical position (of the drone and/or the vessel), depth of the drone, etc., as shown. In that way, accurate geographic addresses for the samples as a function of drone and/or vessel location, is assured.

Diagnostic system 15 also provides for a series of geochemical tests, and includes vacuum separation system 16 and a gas phase analysis network 17. Key to diagnostic results using network 17: determination that hydrocarbon gases are present and what types (using hydrocarbon analyzer system 18) in combination with a gas chromatograph 19, and then isotopic examination via isotopic capture network 20.

FIG. 2 illustrates operation of diagnostic system 15 in still more detail.

As shown, vacuum separation system 16 includes an air-tight chamber 21 for separating the water into liquid and gas phases. Entry and egress from the chamber 21 via a series of inlets and outlets 21A-21C.

Inlet 21A receives the water samples via cable 14 and associated manifold 22. A nozzle 24 breaks water into droplets. Note that even though the flow rate of the water can be as high as 7 liters per minute, usual flow rate is usually about 3.7 liters per minute. The separated liquid phase is discharged from the chamber via outlet 21B and pump 25. The separated gas phase exits the chamber via outlet 21C through vacuum pump 26 and then passes through outlet 27 for eventual testing by isotopic capture system 20.

Also of importance in the operation of diagnostic system 15 is the storage and display of all annotation data via the electrical network/display 34 to allow for determination of geographic addresses of all samples taken by the drone, as previously explained. Manifold 27 includes an arm 28 which terminates in a continuously operating hydrogen flame ionization analyzer 18. Remaining arm 29 of the manifold 27 terminates at multi-port valve 30.

One port 31 of the valve 30 is open to the atmosphere. Another port 32 is disconnectably connected to gas chromatograph 19 which, when operating, providing gas chromatograms. Yet another port 33 of the valve 30 is disconnectably connected to isotopic capture system 20 of the present invention.

Since the gas chromatograph 19 as used in association with operations of the present invention is usual, that is, the gas chromatograph 19 provides chromatograms of hydrocarbon components in the water, emphasis of description is placed on isotopic analysis system 20 of the present invention.

FIG. 3 illustrates how easily isotopic capture system 20 can be transported aboard a vessel 11 in either an assembled or unassembled state and be effectively operated in any type of environment. And since all functions associated with the isotopic capture system 20 occur aboard a sea-going vessel often in a hostile environment, constructional aspects related to portability, reliability and ruggedness are of some importance.

As shown, the capture system 20 includes a series of trapping and stripping stations 35-40 mounted to upright front panel 50 of carry-on capture box 51. The box 51 includes side, top and back panels 52, which form an enclosure interior thereof, wherein equipment associated with operations can be stowed either temporarily as during transport (or permanently as required). Carry handle 53 facilitates hand-transport of the box 51 to and from the vessel. Note also that the front panel 50 intersects bottom panel 58 near its center. Hence, not only can the operator use bottom panel 55 as a floor for equipment associated with stations 35-40, but also he can place a separate cover 54 (shown in phantom line) in attachment with the panels 52, 58 as when transport of the box is required. In that way, the equipment comprising the stations 35-40 can be protected against breakage during transport. Note that the cover 54 has extending side and top panels 55 of reverse orientation with respect to the shape provided the side, top and bottom panels. Result: Disconnectably connecting hinges 56 can be aligned with mounts 57 to releasably attach the cover 54 with respect to the panels 50, 52 and 58.

FIG. 4 illustrates operation of stages 35-40 of

system 20 in more detail.

Assume the operator has allowed dissolved gases to enter the system 20 via valve 60 to station 35 to begin operations.

5 The key to isotopic operation of system 20 lies in quantitative oxidation of the dissolved gases as within oxidation station 39 and subsequent collection at station 40. These operations occur after sinusoidal travel of the dissolved gases via the intermediate stations 35-38 as set forth below. The usual flow rate of the dissolved gases within system 20 is about 30 microliters per minute. The amount of collection at station 40 is dependent on the methane concentration in the sample sea water, the flow rate of the air carrier system, and the separation efficiency of the vacuum separation system aboard the vessel. If the normal methane concentration is 100 microliters per liter of water, and the extraction rate of the drone is 7 liters per minute at depth, then 40 minutes will be needed to collect 20 microliters of the gas of interest at station 40, assuming extraction efficiency at the vacuum system of 75%. In the vicinity of modest gas seeps, the concentration of methane can easily approach 1000 microliters per liter of water (STP) particularly in deep water.

Briefly with reference to FIG. 4, the wet air carrier and the dissolved gases from the vacuum separation center enters station 35 at inlet 61. At the station 35, the gases percolate downwardly through the series of absorbent materials 62 supported in upright tube 63. Materials 62 remove both water vapor and molecular carbon dioxide. Next, the carbon monoxide which also occurs in variable abundance in water, is removed at station 36 by oxidation to carbon dioxide; the latter is subsequently removed from the carrier system after passing via valve 64 to station 37. The carrier gas stream containing both air gases and low molecular weight alkanes is then directed to stage 38 after passage through valve 65.

At the station 38, the lower, mid- and higher-range molecular weight hydrocarbons are removed, that is, all hydrocarbons above C_1 . The remaining methane then enters station 39 where it is oxidized to carbon dioxide. After passage through valve 66 the latter is subsequently retained at station 40. The details of operation of stages 35-40 will now be presented in more detail below.

STATION 35.

Purpose: To trap water vapor and molecular carbon dioxide in the gas phase of the separated sample. The station 35 is constructed of the tube 62 attached to the front panel 50 of capture box 51 upright position, see FIG. 3, the tube 63 usually being constructed of standard wall Pyrex (registered Trade Mark) tubing. A bed of absorbent materials 62 is held in place by small wads of glass wool 67 placed at the ends of the tube 63. The absorbent materials 62 are conventional and are available in the industry for removing water vapor (viz calcium chloride, $CaCl_2$) and for absorbing molecular carbon dioxide (namely, sodium hydroxide, $Na(OH)$). Mixture ratio 1:1.

STATION 36.

Purpose: To remove carbon monoxide which occurs in variable amounts in sea water using a flow-through furnace system 70.

As shown in detail FIG. 5, furnace 70 consists of a helix 71 wound about a quartz tube 72, the tube being previously wrapped with a single layer of asbestos tape 73. The helix 71 is then covered with additional asbestos tape 74 as well as with a glass wool matting 75 forming a sidewall into which a thermocouple (not shown) can be inserted. The ends of the helix 71 and the thermocouple are electrically connected to thermal controller 76 of FIG. 4. The controller 76 supplies regulated power to the furnace as a function of temperature. At the remaining annular space between the sidewall of the wool matting 75 and the glass wall of the tube 70 are positioned cupric oxide wire 77 along with platinized alumina pellets 78. The pellets 78 are placed at the downstream end of the tube 70, and held by quartz wool, not shown. The furnace operates about $125^\circ C$ whereby the carbon monoxide is oxidized to carbon dioxide.

STATION 37.

Purpose: To remove carbon dioxide previously generated at station 36. Station 37 is constructed of a glass tube 80 filled with an absorbent material 81 such as sodium hydroxide, $NaOH$, held in place with glass wads 82, and is similar in construction to station 35 previously described.

STATION 38.

Purpose: To remove lower-, mid- and high-range molecular weight hydrocarbons. Station 38 is constructed of a metallic tube 83 filled with inert chromatographic glass beads 84 in a size range of 60-80 mesh held in place by glass wool wads (not shown). When removal of low- mid- and high-range hydrocarbons is desired (removal of all hydrocarbons above C_1) a bath 85 consisting of liquid argon ($-180^\circ C$) or isopentane-liquid nitrogen slush ($-160^\circ C$) is placed circumferentially about the bed of beads 84.

If desired, station 38 can be by-passed via valve 65. Hence, clean-up of the tube 83 can be facilitated, i.e., a clean gas can be passed via valve 65 through the tube 83 while the bed of beads 84 is heated to a temperature of about $200-300^\circ C$ for several minutes. Note that at temperatures above $400^\circ C$ however, the beads 84 will soften.

STATION 39.

Purpose: To oxidize the methane of interest to carbon dioxide. The station 39 includes a furnace 86. It is similar in design and construction to the furnace 70 of station 36 shown in detail in FIG. 5, except that furnace 86 operates at temperatures in excess $600^\circ C$ in a catalytically aided reaction. The temperature preferred is about $650^\circ C$. Result: methane is quantitatively converted to carbon dioxide at a lower operating temperature than would be normal, due in part to the effect of the cupric oxide helix and platinized alumina beads used as catalysts within the furnace 86. In this regard, it should be noted the combustion efficiency of the furnace 86 at different ranges and temperatures has been tested. A standard hydrocarbon mixture consisting of say 66 parts per million methane, 10 parts per million C_2H_6 , 10 parts per million C_3H_8 , and 10 parts per million C_4H_{10} in a helium carrier, was passed through furnace 86 at 30 milliliters per minute. The test was repeated at 20 milliliters per minute. The vent of the furnace 86 was connected to a gas chromatograph equipped with a

flame ionization detector. At the maximum sensitivity of the detector (approximately .5 parts per million CH₄ equivalent) with the above mixture flowing through the furnace 86 at the above rates, no methane was detected at the detector. The condition continued as long as combustion furnace 86 was above 600°C, say preferably 650°C. Larger amounts of methane were syringe-injected (say up to 400 microliters of methane) into the furnace with similar results. Thus, it is concluded that furnace 86 will quantitatively oxidize all methane concentrations that are likely to be obtained in the field.

STATION 40.

Purpose: To trap microliter quantities of carbon dioxide oxidized at station 39.

Station 40 is constructed of a glass tube 87 bent into a U-shape. Its arms connect to transfer tubes 88 (and its inlet and outlet, respectively) which facilitate gas passage through the tube 87. The tube 87 is also filled with inert chromatographic grade glass beads 89 of average size, say 60-80 mesh forming a trapping bed. Beads 89 are held in place by wads of glass wool (not shown). Collection of the carbon dioxide is effected by immersing the tube 87 and beads 89 in a bath 90 of either liquid argon at -180°C or an isopentane-liquid nitrogen slush at -160°C. Note that at the outlet of the station 40, the transfer tube 88 connects via valve 91 to either (i) flow meter 92 and vent 93 or (ii) to a vacuum pump (not shown). During collection, item (i), above, is connected to the tube 87. After the collection is complete, the valve 91 is operated to connect the interior of the tube 87 to the vacuum pump and the latter is turned on. The transfer tubes 88 are then sealed by heating them with a small

oxy-propane torch. At a mass spectrometer site, the contents of the tube 87 (carbon dioxide) and impurities, if they exist, (air gases, water vapor primarily) are introduced into a vacuum line where the carbon dioxide is purified prior to isotopic analysis. Prior to reusing the tube 87 and beads 89, both are heated to 200-300°C in the stream of clean air to remove organic contaminants. Note that cryogenic trapping by bath 90 can present some problems if the bath temperatures are not maintained within a range of -160 to -180°C. For example, it has been found that at higher temperatures (say -125°C) using an isopentane-liquid nitrogen slush, the carbon dioxide can breakthrough the tube 87 to vent 93 at modest flow rates, say 16 milliliters per minute. At lower temperatures, say -196°C, oxygen can condense on the beads 89 interrupting the carrier flow. Carbon dioxide has been found quantitatively to be retained on the beads 89 at -160°C using an isopentane-liquid nitrogen slush, for 25 minutes at flow rates of about 100 milliliters per minute.

Thus, at air carrier flow rates of 20-30 milliliters per minute, the carbon dioxide will be retained for periods of two hours or more. Moreover, at -180°C, the retention time of carbon dioxide will undoubtedly increase if liquid argon (-180°C) is used.

EXPERIMENTAL DATA

An investigation of isotopic fractionation associated with system 20 of FIG. 4, has been undertaken, such investigation utilizing standard 5% methane-argon and 10% methane-nitrogen mixtures. Results of isotopic examination are as set forth below in Table I.

TABLE I

Sample No.	Std.	Vol. Inj.	Recovery %	Delta ¹³ C (PDB) ‰
HC-11	5% CH ₄ /Ar	50	100	-39.31
HC-12	5% CH ₄ /Ar	50	100	-39.27
HC-13	5% CH ₄ /Ar	100	100	-36.36
HC-14	5% CH ₄ /Ar	100	100	-39.57
HC-23	10% CH ₄ /N ₂	100	100	-26.07
HC-24	10% CH ₄ /N ₂	100	100	-25.45
HC-25	10% CH ₄ /N ₂	100	100	-25.53
HC-26	10% CH ₄ /N ₂	100	100	-26.73
Ref-1	10% CH ₄ /N ₂	—	100	-30.50
Ref-2	10% CH ₄ /N ₂	—	100	-28.11
Ref-3	10% CH ₄ /N ₂	—	100	-29.13

Samples HC-11 through HC-14 show good agreement and demonstrate a high level of precision at two concentration levels of 50 microliters and 100 microliters of the carbon dioxide (STP). Mean and standard deviations of the delta¹³C composition were -39.38 ± .13. reference samples have not yet been analyzed.

Samples HC-23 through HC-26 and reference samples 1-3, provide similar results except the delta¹³C distributions were systematically "lighter" by a value of -3.57 ‰. There is, at present, no explanation for

the systematic bias noted above.

In a parallel study, sea water saturated with a methane/argon mixture at two temperatures (18°C and 2°C) was stripped of its dissolved methane. The dissolved methane was then condensed to carbon dioxide at an air carrier flow rate of 30 milliliters per minute. Approximately 30% of the methane was removed from solution in 10 minutes. Results of isotopic examination are set forth below with reference to Table II.

TABLE II

Sample No.	Std	Vol. Inj.	Recovery %	Delta ¹³ C(PDB) ‰
HC-15	5% CH ₄ /Ar	1495 ^a	32	-40.16
HC-19	5% CH ₄ /Ar	2180 ^a	30	-39.17

a=saturation concentrations in 1 liter sea water at 18° and 2°C.

Note that samples HC-15 and HC-19 represent partially stripped sea water previously equilibrated with the 5% methane/argon mixture, the same mixture used to obtain the results in table I. But also note that the results of Table II are not significantly different than those obtained for samples HC-11 through HC-14 of Table I which were achieved using the same source tank of methane/argon. Of particular interest in Tables I and II, is the fact that the fractionation associated with incomplete stripping of the samples HC-15 and HC-19 in Table II is less than 1‰. This is expected since the fractionation factor is about 1.03 (or the square root of 17/16). That is to say, for small methane stripping efficiencies (less than 1%), the resulting carbon dioxide will be 3‰ lighter than the parent methane. At 30% recoveries, the fractionation is within experimental error.

Isotopic fractionation is dependent on vapor pressures of C₁₂H₄ and C₁₃H₄, each of which being temperature dependent. At temperature extremes likely to be encountered at the surface of the earth (-2°C to 45°C), isotopic fractionation associated with gas extraction should be within experimental error. It is also worth noting that success of the present invention does not depend on the absolute delta C¹³ values provided for either the biogenic or thermogenic methane fractions. Relative changes in a local region are the focus of interest.

CLAIMS

1. A portable isotopic capture apparatus comprising:
 a series of panel members, including front, top, and bottom panel members mounted together to form a box-like structure including a storage zone interior of said panel members, said front panel member intersecting said bottom panel member near a mid-portion thereof, and being fitted with a series of interconnected trapping and stripping stations for performing selected capture of a carbonaceous gas at an on-site location such as aboard a vessel at the surface of a body of water; and
 a series of disconnectable connectable attaching means mounted adjacent to said trapping and stripping stations on said panel members, whereby a separate covering lid having extending top and side wall members of a reverse orientation with respect to those of said associated panel members, can be attached, so that said trapping and stripping stations can be protected from breakage during transport.

2. An apparatus as claimed in Claim 1, in which said stripping and trapping stations include a series of tubes attached to said front panel member including at least one pair of glass tubes packed with absorbent materials, an oxidation furnace supported on a cylindrical support, and a glass capture tube

filled with glass beads interconnected with said oxidation furnace.

3. An apparatus as claimed in Claim 2, in which said pair of glass tubes, said oxidation furnace, and said capture tube are interconnected by glass tubing.

4. An apparatus as claimed in Claim 2 or 3, in which said capture tube is U-shaped and has ends capable of being heat sealed after capture of an oxidation product of said carbonaceous gas for later isotopic examination.

5. A portable isotopic capture apparatus substantially as hereinbefore described with reference to, and as shown in, Figures 3, 4 and 5 of the accompanying drawings.

Application No. 83/24733

New or amended claims 1-5 on pp 18-20 (attached).

1. A portable gaseous isotope capture apparatus for isolating a carbonaceous gas entrained in a water stream taken from a body of water at a known on-site location and passed thereto, the capture apparatus being capable of being positioned aboard a floatable vessel so that accurate indications of hydrocarbon potential of an earth formation underlying the body of water from which said carbonaceous gas was collected can be made, said apparatus comprising:

a series of panel members, including front, top, and bottom panel members mounted together to form a box-like structure including a storage zone interior of said panel members, said front panel member intersecting said bottom panel member near a mid-portion of the latter, and being fitted with a series of interconnected trapping and stripping stations for initially stripping away interfering contaminants of the carbonaceous gas of interest, in a gas stream that has been previously separated from the water stream, and then for performing selective capture of the carbonaceous gas at the on-site location such as aboard the floating vessel at the surface of the body of water; and

a series of disconnectable connectable attaching means mounted adjacent to said trapping and stripping stations on said panel members, whereby a separate covering lid having extending top and side wall members of a reverse orientation with respect to those of said associated panel members, can be attached, so that said trapping and stripping stations can be protected from breakage during transport.

2. An apparatus as claimed in Claim 1, in which said stripping and trapping stations include a series of tubes attached to said front panel member including at least one pair of glass tubes packed with absorbent materials, an oxidation furnace supported on a cylindrical support, and a glass capture tube

filled with glass beads interconnected with said oxidation furnace.

3. An apparatus as claimed in Claim 2, in which said pair of glass tubes, said oxidation furnace, and
5 said capture tube are interconnected by glass tubing.

4. An apparatus as claimed in Claim 2 or 3, in which said capture tube is U-shaped and has ends capable of being heat sealed after capture of an oxidation product of said carbonaceous gas for later
10 isotopic examination.

5. A portable gaseous isotope capture apparatus substantially as hereinbefore described with reference to, and as shown in, Figures 3, 4 and 5 of the accompanying drawings.

Printed in the United Kingdom for Her Majesty's Stationery Office, 8818935, 9/84, 18996. Published at the Patent Office, 25 Southampton Buildings, London WC2A 1AY, from which copies may be obtained.