

Fermilab

TM-1157
7550.537

E-537 MWPC AMPLIFIER

R. Kephart and C. Kerns

September 17, 1979

E-537 MWPC AMPLIFIER

R. Kephart/C. Kerns

September 17, 1979

GENERAL

The design of a fast MWPC amplifier for the beam chambers and the absorber chamber is completed and all parts are on order. A prototype 16 channel board has been built and satisfactorily tested. Artwork is completed for the board and out to be photographed. The board fabrication contract has been let. Listed below is a summary of the amplifier characteristics as well as test results obtained with the prototype.

DESIGN

The amplifier is a version of the E-288 fast amplifier designed by Bill Sippach, modified and improved by C. Kerns in consultation with me. A circuit diagram is shown in Fig. 1. The amplifier is a "time over threshold" type consisting of a fast amplifier and pulse shaper followed by a $\mu\text{A}-685$ comparator with ECL differential outputs. The amplifier is consequently "dead-time-less" and capable of operation at very high rates (i.e., at high rates its simply stays "ON" continually). Although the original Sippach design was used successfully in E-288, its design had several short comings. The most serious was a tendency to oscillate unless very close attention was paid to the amplifier and output cable grounding and output cable geometry. This problem was traced to unbalanced currents flowing in the amplifier ground plane, and to stray capacitance

-2-

feeding fast rise time ($\leq 1/2$ ns) output signals back to the input. Thus in our amplifier design, Cordon took great care in reducing and balancing the currents flowing in the amplifier ground plane. In addition, since we are driving long flat line cables whose dispersion limits the fastest rise time one can obtain at the receiver to ~ 7 ns, it did not make sense to drive them with $1/2$ ns rise time signals. Thus the outputs of the μ A-685 were slowed down with inductors to ~ 5 ns rise time. The ECL "differential" outputs were balanced using a multifilar wound toroidal transformer to insure that they were truly differential. Finally extensive geometry changes and a bypass capacitor were added to reduce output to input coupling, and the original μ A-687 dual comparator was replaced by 2 μ A 685's to eliminate adjacent channel cross talk induced by the original chip.

PROTOTYPE TEST RESULTS AND SPECIFICATIONS

Test Setup

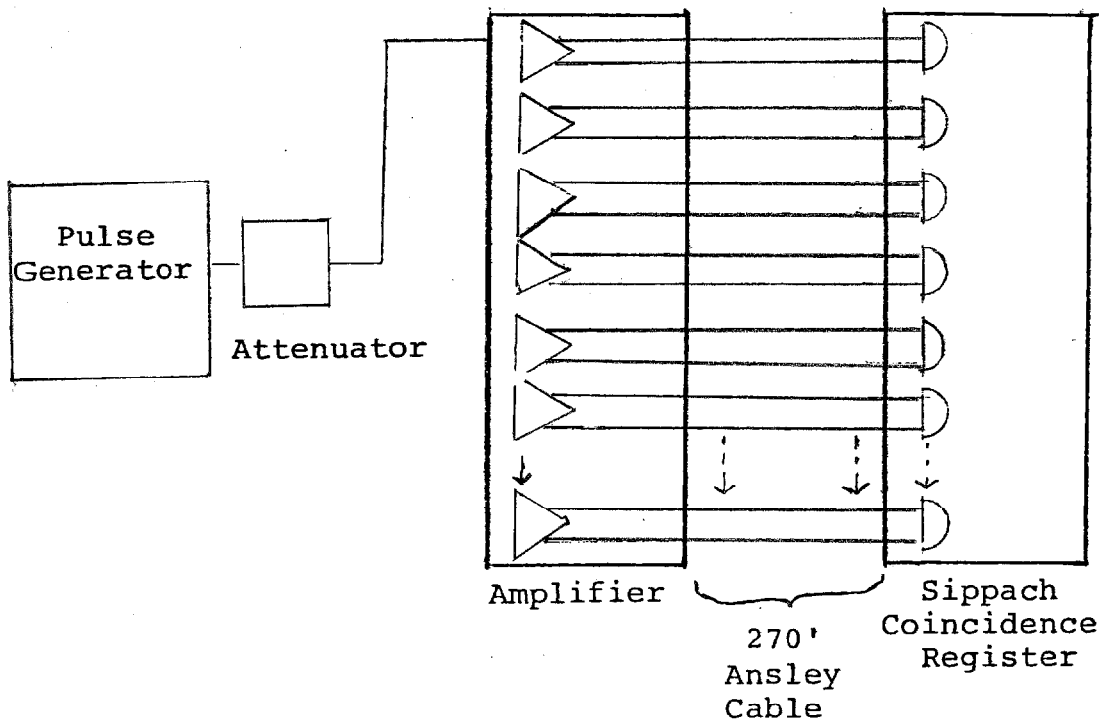

-3-

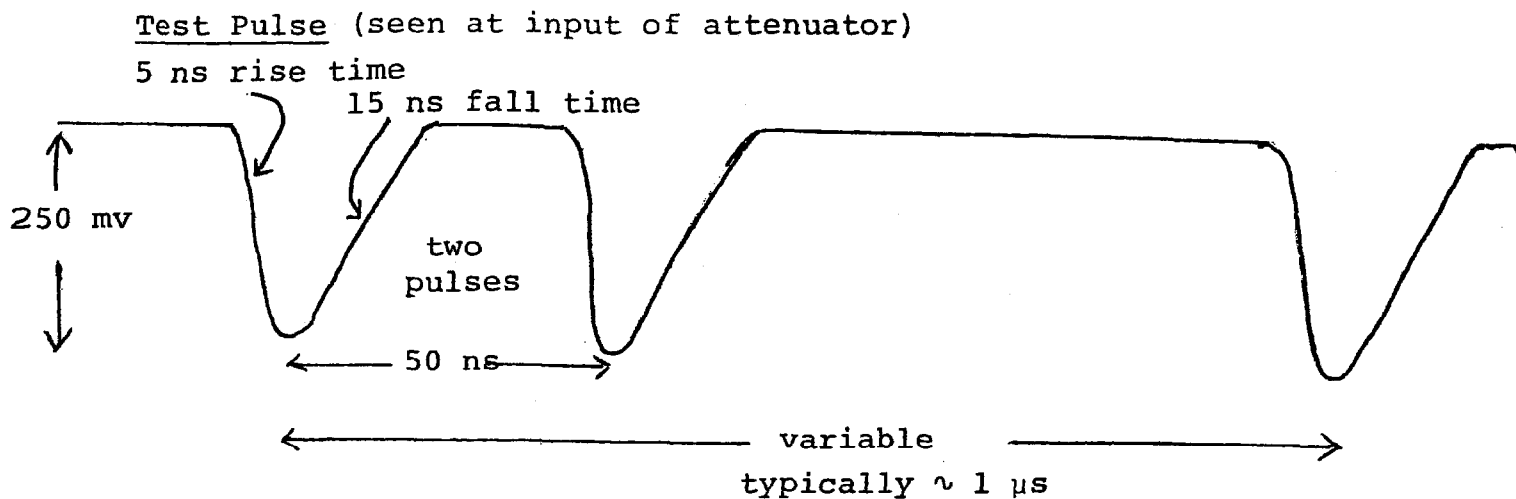

Pulse shape was chosen to simulate that expected from chambers.
Repetition rate was typically 1 MHz.

Results

Power Requirements	+ 6 V	875 ma	} ~ 10.5 watts/card
	- 6 V	862 ma	

Sensitivity

Minimum Threshold:	Oscillation occurs at threshold corresponding to $\sim 100 \mu\text{v}$.
Stable Operation Threshold:	For 60 db attenuation $\Rightarrow 250 \mu\text{v}$ input signals stable operation well above oscillation with full efficiency is easily obtained (Threshold voltage applied 2.8 V).

Time Slewing Test

(5 ns rise time test signal shown above)

(Threshold set at 3V $\Rightarrow 125 \mu\text{v}$).

<u>Signal Size</u>	<u>Time</u>	
250 μ v	t = 0	} consistent with signal rise time
2.5 mv	t = 5 ns	
2.5 mv	t = 6 ns	

(Change to 1 ns rise time signal)

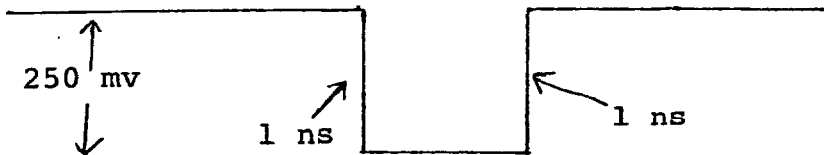

(Threshold at 3v = 180 μ v for this rise time)

<u>Signal Size</u>	<u>Time</u>
360 μ v	t = 0
3.6 mv	t = 4ns (2 ns to 1/2 height)
36 mv	t = 6 ns (4 ns to 1/2 height)

Conclusion: Amplifier
time slewing < 5 ns.

Cross Talk (typical test)
Observe Channel #1 output
with input floating,
threshold = 3v \Rightarrow 125 μ v
sensitivity, inject signal
into channel #2

Conclusion: Channel #1
Fires when signal into #2 exceeds
30 mV \Rightarrow dynamic range = $\frac{30}{0.125} \sim \frac{240}{1}$

Same, but threshold =
5V \Rightarrow 180 μ v

Channel #1 fires when signal into
#2 exceeds 80 mV $\Rightarrow \frac{80}{0.2} = \frac{400}{1}$

Numerous other similar cross talk
tests were performed all looked
quite reasonable.

Magnetic Field Test

Since amplifier contains ferrite inductors and toroid a test was made of the effects of fringe field etc.

Conclusion: a 1.5 Kg field lowers output pulse by $< 15\%$ in "worst" orientation \Rightarrow fringe fields are no problem. NOTE: Amplifier can be operated without toroids or inductor with reduced performance for operation in high magnetic fields.

REV.	DESCRIPTION	DRAWN	DATE
		APP.	DATE

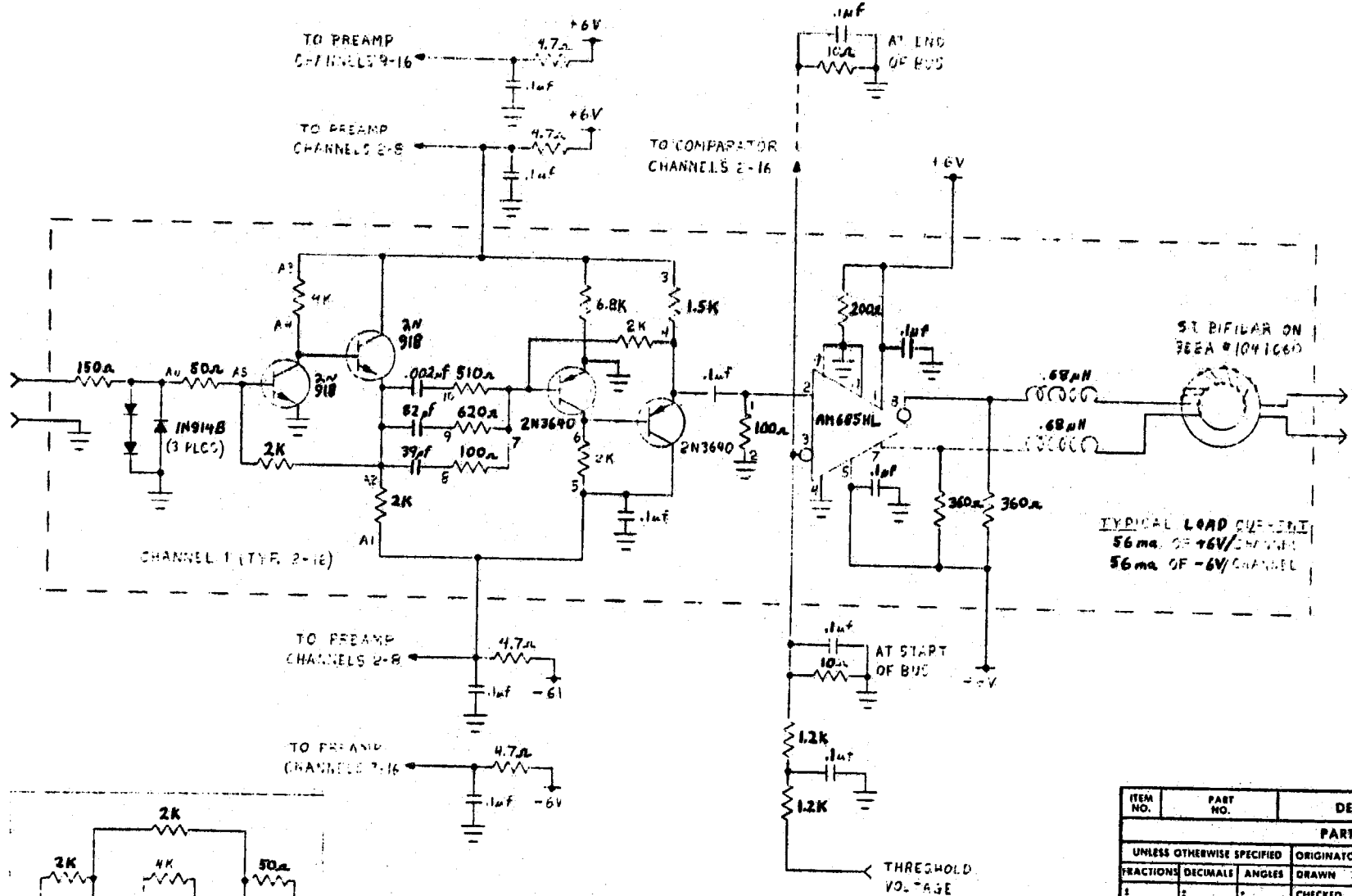

TYPICAL LOAD CURRENT
56 ma. OF +6V/CHANNEL
56 ma. OF -6V/CHANNEL

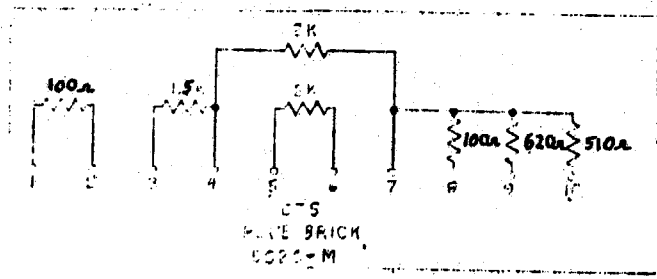
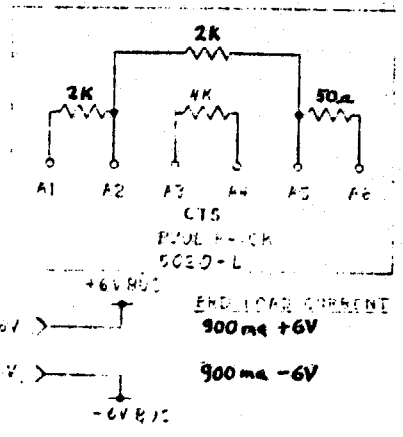

ITEM NO.	PART NO.	DESCRIPTION OR SIZE	QTY. REQ.
PARTS LIST			
UNLESS OTHERWISE SPECIFIED		ORIGINATOR	1145/C KEH/1
FRACTIONS	DECIMALS	ANGLES	DRAWN
1	2	3	5/25/79
1. BREAK ALL SHARP EDGES 1:64 MAX.		CHECKED	
2. DO NOT SCALE DWG.		APPROVED	
3. DIMENSIONING IN ACCORD WITH ANSI Y14.5 STD'S.		USED ON	
✓ MAX. ALL MACHINED SURFACES		MATERIAL-	
FERMI NATIONAL ACCELERATOR LABORATORY UNITED STATES DEPARTMENT OF ENERGY			
E-537 16 CHANNEL FAST MWPC AMP			
SCALE	FILMED	DRAWING NUMBER	REV.
		5537-EG-114333	