

Salvatore Giordano and Mario Puglisi
Brookhaven National Laboratory
Upton, New York 11973

DE83 010061

CONF-830311-30

Summary

In circular accelerators and particularly in storage rings it is essential that the total impedance, as seen by the beam, be kept below some critical value. A model of the accelerating system was built using a single-ended cathode-follower amplifier driving a ferrite-loaded cavity. The system operated at 234.5 KHz with a peak output voltage of ± 10 kV on the gap. The dynamic output impedance, as measured on the gap, was < 15 ohms.

Introduction

High intensity beams in circular accelerators and storage rings require that the gap coupling impedance of the vacuum chamber and associated equipment be very small over a wide frequency range. For the case of the accelerating cavity and RF amplifier there are two methods that can be used for lowering the impedance: 1) shunting the cavity with a resistor and 2) using an amplifier with negative feedback. For the Colliding Beam Accelerator (CBA) it would be desirable to have a gap coupling impedance of 15Ω per gap or less. With a peak gap voltage of 12 kV it is obvious that resistive loading would require a prohibitive amount of RF power.

The use of an amplifier with negative feedback is the best choice from an economic point of view, but there are some technical problems that must be considered. There are three basic amplifier circuits: grounded cathode, grounded grid and grounded anode (cathode follower). The first two circuits have been extensively used in the past; both with and without feedback. The feedback loop for use with the above two circuits must, by the very nature of the circuits, contain two or more phase lag elements; consequently, to insure stability, severe restrictions must be placed on the gain bandwidth. It should also be noted that by the very nature of the physically large components used, parasitic reactances associated with these components will adversely affect the amplifier.

The big advantage of a cathode follower is that no external feedback network is required to achieve a feedback ratio of $\beta \gg 1$. The disadvantage is that a cathode follower can become unstable under certain conditions when the load is reactive, but it will be shown that it can be easily stabilized with a damping resistor and essentially not effect its bandwidth and low output impedance.

Amplifier Considerations

If we are to maintain a low dynamic output impedance over a wide frequency range it is important that the tube or tubes be conducting over the whole of the RF cycle; moreover, the concept of impedance implies a linear circuit. The effect of beam loading will influence the selection of both the amplifier circuit and operating conditions of the tubes to satisfy the above requirements.

It has been shown that amplifiers with resonant loads can be operated in a nonlinear fashion (where

the tube cuts off) and still effectively reduce beam loading effects. The concept of impedance becomes meaningless, but an effective, conservative design is possible. This paper will not deal with this concept or design; a more detailed study of non linear beam loading effects will be found in the Reference.

Push Pull vs. Single Ended

In addition to an output impedance of 15 ohms or less for each amplifier, the CBA amplifier must meet the following requirements: peak voltage ± 12 kV and a peak (I_p) and average (I_a) beam current of 40 amps and 8 amps respectively (see Fig. 1). It should be noted that in order to maintain a low output impedance the peak beam current becomes almost equal to the instantaneous dynamic tube current; therefore, the amplifier tube must be capable of conducting the peak beam current without going into saturation. For a push pull amplifier as one tube is being driven into saturation, it is also necessary to keep the second tube from being cut off.

The single ended amplifier to be described in this paper, that was constructed and tested, was limited to an output voltage of ± 10 kV. For economic reasons we used an existing power supply and filter capacitors, which limited the system from operating above this level. We feel that operation of the amplifier at ± 12 kV will be no different than what was observed at ± 10 kV.

Let us consider the simplified push pull amplifier and cavity system as shown in Figure 2A. Figure 2B is the equivalent circuit, where I_b is the beam current as shown in Figure 1, and I_1 and I_2 is the instantaneous current in each tube when $I_b \neq 0$. With I_b not equal to zero, the instantaneous currents through tube 1 (T1) and tube 2 (T2) are $I_1 = I_{Q1} - I_p$ and $I_2 = I_{Q2} + I_p$ respectively, where I_{Q1} and I_{Q2} are the quiescent tube currents. To prevent T1 from cutting off, I_{Q1} must be sufficiently high to keep I_1 from going negative. Allowing a 3 amp margin we get $I_{Q1} = I_1 + I_p = 43$ amps. On the other hand, I_{Q2} can be 3 amps and not have T2 cut off. If the amplifier is to deliver ± 10 kV peak then the DC voltage to the amplifier would be about 6 kV, resulting in a total quiescent DC power input to the amplifier of 276 KW. Note that the push pull amplifier is being operated in an asymmetrical fashion, otherwise the DC power would have been much higher.

Let us now consider the simplified single ended amplifier and cavity system as shown in Figure 2C and its equivalent circuit as shown in Figure 2D. To prevent the tube from cutting off, there are a number of factors that must be considered for determining the quiescent tube current, I_Q ; the beam current shape, the amplifier-cavity time constant, and the stable phase angle. The required value of I_Q , for the beam current shown in Fig. 1, can have a value between 1 to 8 amps. To develop a gap voltage of ± 10 kV, we need a DC voltage of 11 kV; therefore, the maximum quiescent DC power input to the single ended amplifier is 88 KW. The operating DC power input could be greater than 88 KW, but generally it will be considerably less than the 276 KW for a push pull amplifier.

From the above, it is obvious that the best choice from the point of view of DC power requirements is the single-ended amplifier. Based on the

*Work performed under the auspices of the U.S. Department of Energy.

MASTER

above consideration of linear operation it should be noted that the large difference in DC power requirements is due primarily to the large ratio of I_p to I_a ; as this ratio approaches a value 2, the DC power input for the push pull and single ended amplifier become equal.

The Single Ended Cathode Follower As An Amplifier

Figure 3A is a simplified diagram of a single-ended cathode follower driving a resonant cavity having a resonant frequency of f_0 , and Figure 3B is its equivalent circuit. It can be shown that at certain frequencies above f_0 , where the cavity has a negative reactance, the input impedance can have a negative real part, and, depending on the associated circuitry, may result in an instability of the amplifier. A more detailed analysis appears in the Reference.

To prevent oscillation the negative resistance must be compensated for by adding a sufficiently large positive resistance in series with the input circuit. Figure 4A shows a cathode follower with its damping resistor R_g and a resonant driver transformer. As previously noted, the possibility of an instability occurring will be at a frequency above f_0 ; a simplified equivalent circuit at these frequencies is shown in Figure 4B, where R_d and $C'd$ is the equivalent impedance of the driver tube and resonant coupling transformer, respectively. The negative resistance, responsible for an instability, can be compensated for by the proper selection of R_g , R_d , and $C'd$. This circuit does result in a small reduction in the feedback ratio of the cathode follower and a corresponding small increase in the output impedance.

In the amplifier to be described that was constructed and tested, the grid to anode (ground) capacity, C_{gp} , was deliberately increased by adding an external capacitor so as to maintain a low output impedance over a wide frequency range. By making C_{gp} equal to the internal tube grid to cathode capacitance, C_{gk} , the feedback ratio was reduced to 0.5, and the corresponding output impedance of the cathode follower is $2/G_m$, where G_m is the transconductance of the tube.

Model Of a Single-Ended Cathode Follower Amplifier

Shown in Figure 5 is a schematic of a model amplifier that was constructed and tested. A more detailed study of the circuit, as previously noted, appears in the Reference. Figure 6 is a photograph showing the ferrite cavity, output cathode follower, coupling transformer and driver amplifier. The cavity and coupling transformer will be described in some future reports, but these items follow some conventional construction practices. The only comment to be made at this time is that the coupling transformers should be designed with a high coupling coefficient (k), otherwise both the output impedance and stability will be adversely affected. In our case k was greater than 0.95.

An interesting feature of the system is the ripple suppression circuit; this will be discussed later on in this paper.

An important advantage of the circuit shown in Figure 5 is that the output of the cathode follower amplifier is connected directly to the gap of the cavity. In a conventional grounded grid or grounded cathode amplifier a coupling network is required to isolate the tube anode voltage from the cavity. This network adds an additional series impedance between

the output of the amplifier and the cavity; which, obviously, increases the impedance as seen across the gap of the cavity.

Measurements

The resonant frequency of the system is 235.4 kHz (the third harmonic of the CBA revolution frequency), and the measurements were made under the following operating conditions: anode voltage 11 kV, and various quiescent tube currents from 1 to 5 amps. Measurements were made both with and without a coaxial load resistor of 2000 ohms across the cavity gap. The dynamic output impedance (without any RF drive to the cathode follower) was measured using a transmission line (this system will be described in a future paper).

The system was found to be very stable under all operating conditions of load and drive levels. The dynamic output impedance, as measured across the gap was 13 ohms or less up to a frequency of 10 MHz.

It is important to point out the difference between the measured impedance across the gap, 13 ohms, and the calculated cathode follower impedance of 7 ohms. This difference is due to the impedances transformations that are associated with the physical length of the tube and the connecting transmission line (which is approximately 12 inches long) between the output of the tube and the cavity. Although it was not possible to make a valid impedance measurement directly at the output of the cathode follower, a cold (tube off) substitution method was used. It was found that a 10 ohm resistance at the tube terminal was transformed, due to the connecting transmission line, to 13 ohms at the gap of the cavity. It is reasonable to assume that the physical length of the tube accounts for the calculated 7 ohm impedance of the tube being transformed to 10 ohms at the output terminals of the tube. Clearly, this dictates that the tube should be mounted directly on the cavity.

Ripple Suppression

Due to the filament of the cathode follower being directly heated from the AC line some 60 cycle and higher harmonic amplitude modulations was observed. Preliminary tests of the dynamic and passive ripple suppression feedback system showed great promise. Our instrumentation, at this time, did not permit very accurate measurements, but it appeared that the total ripple was less than 1% at the full output voltage of ± 10 kV. By making use of a simple passive 60 cycle humbucking signal, it was possible to reduce essentially all of the 60 cycle components of modulation of the output signal. The design of the dynamic system is relatively simple since the bandwidth is only 60 Hz to 2 kHz which is far removed from the RF frequency of 235.4 kHz.

Some thought was given to a DC filament supply using either a transformer and rectifier or a dynamo generator, but neither of these seemed to be a practical solution. Since the filament swings up and down with the peak RF voltage, either of the above solutions would have resulted in capacitive loading due to the large physical components that would have to be mounted directly on the filament.

Future Work

As was noted in this paper, the DC power input efficiency of a single-ended or push pull amplifier depends on the peak beam current. For the CBA accelerating amplifier, where the peak current is 40

amps, the single-ended cathode follower is almost mandatory.

The stacking RF system for CBA, operating at a frequency of 4.45 MHz, has a much lower peak beam current. Presently the design of a push pull cathode follower is being studied. It is felt that such a design has the advantage that it can be neutralized; consequently, the dependence of the driver impedance on the stability requirements is greatly reduced. Concern for push push modes will have to be addressed, but the circuitry for push push mode suppression is independent of the push pull mode.

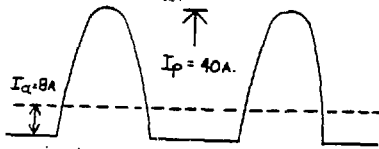

Fig. 1 Typical Beam Current

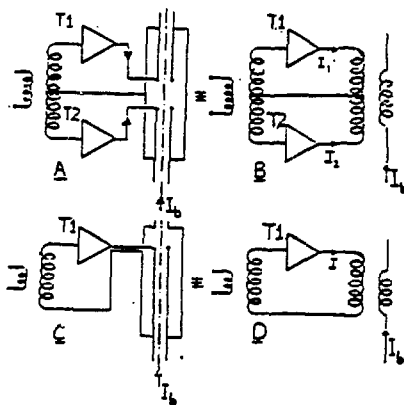

Fig. 2 Push-Pull And Single Ended Amplifiers

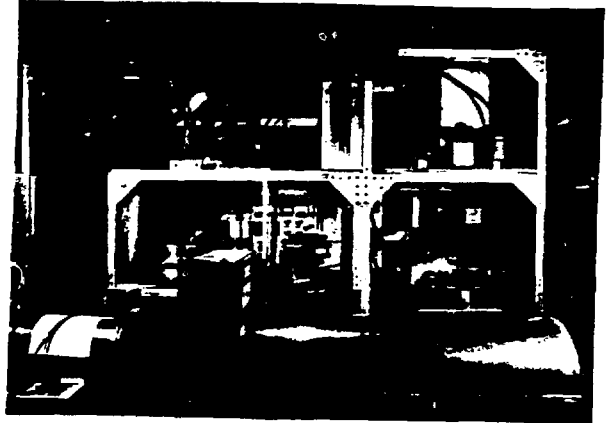

Fig. 6 Model Amplifier And Cavity

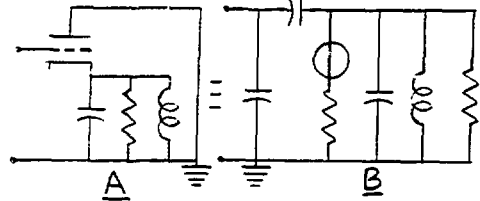

Fig. 3 Cathode Follower Driving A Resonant Cavity

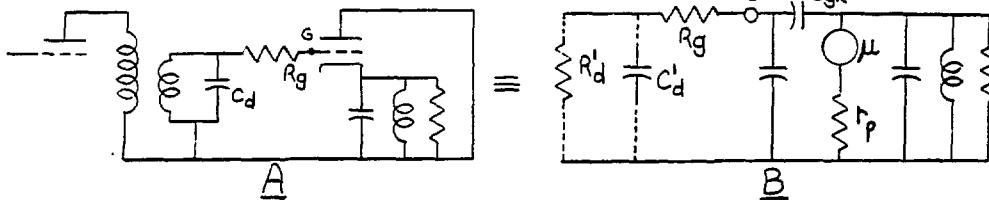

Fig. 4 Driver Amplifier, Cathode Follower and Cavity

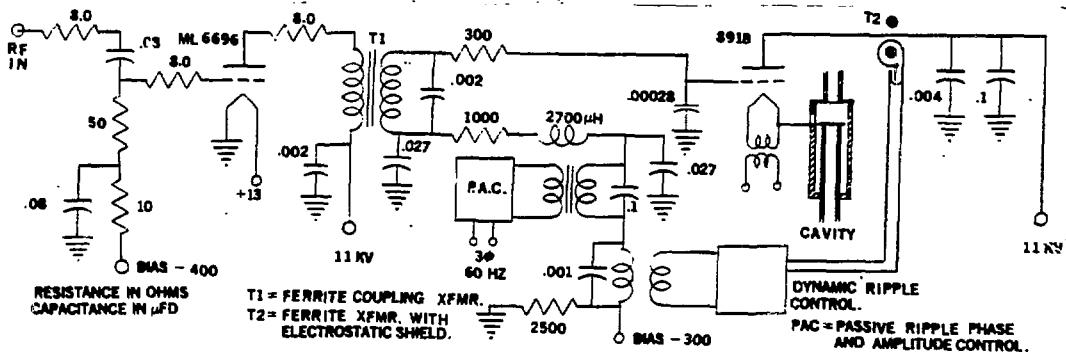

Fig. 5 Circuit Diagram of System

Acknowledgment

We would like to thank Lou Mazarakis, Frank Dicrescio and Phil Warner for constructing and testing the cathode follower amplifier.

Reference

A Linear and Non-Linear Analysis of High Power RF Amplifiers by M. Puglisi. 1983 Particle Accelerator Conference.

S. Giordano: Proceedings of the 1975 Isabelle Summer Study, BNL 20550, pgs. 500 to 514.

DISCLAIMER

This report was prepared as an account of work sponsored by an agency of the United States Government. Neither the United States Government nor any agency thereof, nor any of their employees, makes any warranty, express or implied, or assumes any legal liability or responsibility for the accuracy, completeness, or usefulness of any information, apparatus, product, or process disclosed, or represents that its use would not infringe privately owned rights. Reference herein to any specific commercial product, process, or service by trade name, trademark, manufacturer, or otherwise does not necessarily constitute or imply its endorsement, recommendation, or favoring by the United States Government or any agency thereof. The views and opinions of authors expressed herein do not necessarily state or reflect those of the United States Government or any agency thereof.