

CIVIL ENGINEERING for a JAPANESE SUPERCOLLIDER

F. Takasaki, Y. Watanabe and Y. Watase

Department of Physics, KEK, Oho-machi, Ibaraki-ken, Japan

Abstract

We searched for a land in Japan where an accelerator complex with a diameter of 30 km is to be built. We found some places where we can build tunnels for such machines with a cost of about hundred billion yen in four years.

1) Introduction

1-1) Why hadron collider?

The progress in the high energy physics in the last decade was remarkable. People have acquired a good knowledge on the fundamental structures of the particles and their interactions and people have built a standard model of particles and their interactions which is believed to work at energy regime accessible by the present accelerator.

In the standard model, there are two energy scales, M_w and M_p , the mass of the weak boson and the Planck mass. There is not any other measure of energy scale between the two masses. Some people argues that there is only a 'desert' in between (S. Glashow ; HUTP-79/A059) while other people speculate that there should be some new phenomena, for example, the existence of supersymmetric particles (foe example, J. Ellis; CERN TH 3802) or the onset of the thaw of fermions into their substructure. As far as the energy of new anticipated phenomena are concerned, theoretical predictions are not so definitive as was the case for the W and Z . Therefore it is required to explore experimentally the energy regime well larger than the M_w .

The present highest energy machine, the hadron collider at the Fermi national laboratory, will cover the energy of about 2 TeV in the CMS. The useful energy is, however, about 1/10 of that, about 200 GeV, which is only twice of M_w . This energy is also covered by the LEP. The energy regime to be explored in the next decade should be at least 10 times larger than the energy accessible by the present machines, or a few TeV effective energy. It means to have a hadron collider of a few times 10 TeV or a electron-positron collider of a few TeV.

It is true that the most exciting and valuable discoveries are some time not what are anticipated or predicted. However, the following subjects will be among the most interesting topics in the new generation accelerators.

- 1) Search for the Higgs particle,
- 2) Search for the fermions of fourth or higher generations,
- 3) Search for the substructure of quarks and leptons,
- 4) Search for the supersymmetric particles.

Generally speaking, the cross sections of producing heavy particles drop usually inversely proportional to the mass square. For example, the cross section of producing one TeV particle is 10^{-4} of that of 10 GeV particle. Therefore it is required that the new machine should have quite high luminosity.

It is said that the hadron collider and the electron collider are complementary. As a well known example, following facts are reminded;

The discovery of the charmed quark and the bottom quark was made by the hadron machine first but their identification as quarks was made by electron colliders. The discovery of tau lepton was possible only by a electron-positron collider.

The hadron collider can cover higher and wider energy range but the center of mass energy of the produced heavy objects are not known well, whereas the electron-positron collider provides well known center of mass energy of the reaction but the accessible energy with the present technology is quite limited. It is desirable to have both electron and hadron colliders with equal effective center of masses.

The discovery of W and Z and possibly t-quark at the pp collider at CERN convinced people that the hadron collider is not so dirty machine as to obscure all of the sweet events with large mass production and encouraged people to think about higher energy hadron colliders as the next generation machine. Furthermore the next accelerator is a first mission to the unknown world and their task is to explore the general feature of that world with the expectation of the subsequent missions with much more precise means of exploration. From this view point, the hadron collider is more suited as the first mission in the present situation of the high energy physics.

There are already proposals to build hadron colliders of about 10 TeV, namely, SSC in the USA and LHC at CERN. Especially 'R & D' project of SSC was approved officially by the USA government. On the other hand, the construction of multi-TeV electron-positron collider is to be proposed after years of R & D. (B. Richter - ICFA 84)

1-2) Japanese future high energy machine

The frontiers of high energy physics will arrive at the energy regime as high as 10 TeV in the next decade, as was mentioned above. It is a time for us Japanese high energy physicists to think about how to face with the present movement of physics.

To consider our own future project, it is instructive to look back the history of building up of the high energy physics activities in Japan. The Japanese high energy physics started quite late. The experimental physicists' potentiality in physics and the available machine energy have been always well behind the active frontier of high energy physics abroad. In the last decade the number of experimental and accelerator physicists has increased and they have had many experiences on the physics researches. We have gotten strong financial support from the government. With the construction of the TRISTAN, the Japanese high energy community will be counted as a member of a

high energy society of the world. We should keep this activity built by our precedents and by ourself forever. The TRISTAN will cost about 85 billion yen. It is quite a big amount of money. Can we plan our next generation machine on the assumption of the continuation of the same level of the financial support from the government?

Let us first consider how much will the next generation machine cost. It is estimated that for the SSC we need more than 750 billion yen. Even if it is divided by five years, we need annual 150 billion yen, which is about the total budget that the ministry of education and culture has spent yearly for the national laboratories in the last few years. Fig. 1 shows by the black circles annual budget for the national laboratories financed by the ministry of education and culture in the last two decades. By this money all of the buildings, large facilities and the running money for many researches are financed. It shows that the spending for the national laboratories has been leveling off since 1980. In the same figure, the annual KEK budget is plotted (crosses). It has been increasing sharply since the day of the foundation of KEK in spite of the leveling off of the total resources. But the budget of 1985 did not grow as it was. The monotonous increase of the budget for the high energy physics will not be expected in the coming years because it becomes more than 10 % of the total resource that the ministry of education and culture can supply. This suggests that to get the financial support for the SSC class machine from the government will be extremely difficult. The 300 GeV x 300 GeV electron-positron collider will also cost as much as about 300 billion yen. (I. Sato - High Energy News, Vol 2, No. 10, 1983) The reasonable next generation machine will cost several times more money than the TRISATN. So we are going to face the cold winter days in the near future. We have to think about how to keep the high energy activity in this winter day.

Nevertheless we will assume for the moment that our future prospect is bright and that the next generation machine be financed.....

There is a group of people who argue following way;

Since the hadron supercollider will be built in the near future in the USA or in Europe, we should have an electron-positron collider in Japan.

We can not agree with this arguement. Because as was discussed previously.

a) We believe that what to be made next is to know the general feature in the new world and may not be stressed on a precise study of restricted energy interval.

b) The technology to build a TeV class electron-positron collider is not yet established. It could be possible that it takes long time to get the desired energy and that the most important physics objects be studied by the hadron collider.

c) The electron-positron collider is suited for the detailed study at some specific objects at some energy region. So it can start after we know exactly where to go.

d) It could happen that the machine energy is out of the range of producing phenomena of current interest, as we have had in Japan. Then it will be quite difficult to let the tax payer convince the importance of the high energy machine even if we could not find anything new after spending huge amount of money.

e) There are groups of people in foreign countries, who would like to build the linear electron-positron collider. They have been working for some time on this subject. It is more likely that they will build machine much ahead of us and will survey most interesting parts of physics.

f) It will be quite difficult to have an international agreement to assign a kind of machines to be built at some region of the world, as to build the electron-positron collider only in Japan.

People would ask what we would like to do next.

Do we plan to build a hadron collider in Japan? " Why not! "

Do we plan to join the hadron colliders abroad? " Why not! "

Do we give up to have next generation machine in Japan?

" We would not like to do so. "

It is of course desirable to have our own machine in Japan. We believe that the high energy physics is one of the most fundamental researches and the challenge of human being to explore higher and higher energy will not stop forever. The desire to have the people's own high energy machine is quite strong as we have learned from the last ICFA meeting at KEK. To construct machines by the international collaboration will not be realized in the near future. Therefore, Japanese people will also never give up to have its own machine.

Meanwhile we know as a reality that the construction of the next generation hadron collider will start soon in the foreign countries. If we have enough money on right time, we will try to build our own collider. But if not, we should try to find ways to join the foreign projects so that we should keep the activity of the high energy physics and wait for some time to have its own machine until the time comes.

2) Japanese hadron collider

Although it is quite unlikely that such huge amount of money as high as 750 billion yen will be approved by the Japanese government in the near future as we have seen previously, we have studied a construction of a hadron collider of about 50 TeV on 50 TeV in Japan.

Among others, many people think apriori that there is no place in Japan large enough to accommodate an accelerator complex as large as 30 km phi. And also they think the land is too expensive to be able to buy an enough space. It is quite natural to think so, because the people around KEK know that the construction of the 3 km long TRISATN tunnel costs about 30 billion yen. If one extrapolate it to the 100 km long tunnel, the tunnel will cost about 1000 billion yen. This is twice as much as what the SSC is estimated to cost including every thing. If it is true, the construction of a collider with a

circumference of larger than 100 km is out of question.

Are there no land in Japan?

It is against our knowledge that Japan is a country mostly covered by the mountains and that the mountain area is quite poorly inhabited. So there should be some place large enough for the next machine.

Is the technology to dig tunnels not well developed in Japan?

This is against our knowledge that there are many subways and tunnels for the trains and the cars. Japanese companies have won international bids for digging tunnels many times.

There should be some reasons why the TRISATN tunnel is so expensive compare with the accelerator tunnels abroad. So we studied the construction of a tunnel as long as 100 km with the emphasis on the economical point of view. In the following, we report on the effort to find an appropriate land and on the cost estimation of the construction of a tunnel.

3) Parameters of the accelerator

We design a hadron collider with energy larger than that of the SSC, which is 20 TeV on 20 TeV. We take the energy to be 30 TeV on 30 TeV. We assume the field strength of the superconducting dipole magnets to be larger than 8T. The parameters of the collider are listed below;

Minimum beam energy	30 TeV
Field strength	8 T
Bending radius	12.5 km
Mean radius	15.0 km
Circumference	94.0 km
No. of Interaction points	4
No. of Service stations	20
Energy of the first stage booster	50 GeV
Energy of the second stage booster	1 TeV

We show a top view of a designed accelerator complex in Fig. 2.

4) Tunnel size, experimental halls and service stations

To protect peoples against radiation by energetic particles, the accelerators have to be shielded by the soil or rock walls. Usually the tunnel is constructed underground. It can be of course built in the sea or in the air. Since Japan is surrounded by the sea, it is quite attractive to have an accelerator in the sea water. Especially interesting fact is that if it is built in the sea, then it is quite easy to expand the scale than in the land. Unfortunately, we were informed by the expert that it will be much more expensive to have a tunnel in the sea water than in the ground with the present technology. It may change in the near future. But we consider to have an accelerator in the land in the present study.

To accommodate superconducting magnets with the cross section of about 0.5 m by 0.5 m and power supply lines and also

to have a space for a man to work beside the magnets, the working cross section of the tunnel is about 3 m in diameter. Fig. 3 shows a view of the cross section of the tunnel. It has a horse shoe shape to carry the rock pressure and it has a water drain beneath the floor. It keeps the tunnel dry. The wall is made of 50 cm thick concrete.

Drawings of the experimental hall are given in Fig. 4. The dimensions are about 40 m long and 20 m phi. It accommodates a detector $15 \times 15 \times 15 \text{ m}^3$. The service station is shown in Fig. 5. The devices to cool down the helium are installed in this space.

5) The selection of a land in Japan.

For the people to design the tunnel under the ground, it is a common knowledge that it is easier and cheaper to dig tunnels through the harder rocks. For the hard rock, one need not worry about the collapse of the digged tunnel. One can dig the tunnel by quite a simple way, namely, by using the explosion method, which is the cheapest way of digging the tunnel. The relation between the cost and the hardness of the rock is shown in Fig. 6. There is a minimum in cost, where the hardness of the rock is about 4 km/sec in the velocity of the sound through the rock. The hardness and the speed of the sound through the rock is related proportionally. These rocks are for example the granite. It is an igneous rock and it is quite abundant in Japan.

To dig a tunnel, it is preferable to have a land made of a homogenous material and no faults across the tunnel. As every people knows, Japan is a land lived by devils to produce earthquakes and it is difficult to find places without any fault for the space to accommodate a tunnel as large as 30 km in diameter. Fortunately, however, there are some places that satisfy that criterion.

The figure 7 shows a land map of Japan. One sees the black spots scattered evenly over the land. They are the land of the granite. If one sees it closely, however, they are severely interleaved by the other rocks. The homogeneous hard rock lands as large as 50 km by 50 km are only seen in the Fukushima and Iwate-prefectures. The former is made of granite and closer to Tokyo, a place of resource of labor and we examine the Abukuma area of Fukushima prefecture in the following section to fit the tunnel of a hadron collider.

6) Construction cost and time estimation

The tunnel fitting in the Abukuma area was made by the Pacific Consultant Ltd..(The detailed description of the estimation will be published elsewhere.) Fig. 8 shows the plan view of the tunnel site. Fig. 9 shows the elevation view of the land along the tunnel.

The construction cost was estimated by the same company. It is proportional to the amount of the rock to be removed. The cross section of the tunnel is about 12 m^2 . Roughly speaking, to remove one cubic meter of soil or rock, it costs about 50 k¥. So to dig a tunnel costs about 0.60 M¥/meter. Therefore it costs about $0.60 \times 100 \text{ billion¥} = 60 \text{ billion¥}$ for the main tunnel.

The construction of the approaching tunnels has to be included to the cost estimation. 20 approaching tunnels are planned to dig the main tunnel. They are horizontal, tilted or vertical tunnels depending on the land shapes. They amount to about 20 billion ¥. If one adds also the construction cost of the booster tunnels, the total cost will be about 90 billion ¥. This number is quite consistent with what the LEP tunnel will cost. The LEP tunnel goes through the hard rock and its circumference is about 30 km. It is estimated to cost about 30 B¥ or 1 B¥/km. (LEP-pink book -- 1980) It is about three times more money than the cost of the TRISTAN tunnel.

The construction can be finished in four years. The detailed estimation made by the company is given in the following table.

items	total length	cost/m	cost
main tunnel	94,200 m	631 k¥	59,440 M¥
vert. approach tunnels (10)	2,990 m	2835 k¥	8,477 M¥
tilt. approach tunnels (10)	6,070 m	1654 k¥	10,040 M¥
approch. roads	4,300 m	200 k¥	860 M¥
exp. halls (4)		363 M¥	1,452 M¥
service stations (16)		40 M¥	640 M¥
2nd booster tunnel	9,425 m	631 k¥	5,944 M¥
approach tunnel for 2nd booster	637 m	1654 K¥	1,053 M¥
1st booster tunnel	1,571 m	631 k¥	991 M¥
total cost			88,897 M¥

For comparison, we tried to fit the hadron collider at the Tsukuba area, because it will be quite advantageous to have machine around KEK. The Mt. Tsukuba is made of hard granite so it is favorable. However the rock is too small to fit the collider. The rock of the Mt. Tsukuba is quite steep and the rock runs about 500 m under the ground level at KEK. So in the Tsukuba option, the main part of the tunnel goes through the soft soil, the worst case. Nevertheless we examined the Tsukuba option. The figure 10 shows the plan view and the figure 11 shows the elevation view. As one sees the main part goes through the soil. To dig a tunnel through the soli, it is estimated to cost about 4 M¥/meter, six times more money than that through the hard rock. Although the approaching tunnels are shorter and cheaper than the Abukuma case, the total cost for the whole accelerator complex estimated by the Pacific Consultant Ltd. amounts to about 400 B¥, about four times more than the Abukuma case. So the KEK site is, unfortunately, the worst place from the view point of digging a tunnel.

7) Cost to buy the land and possible indemnity

People would ask how much it will cost to buy the land for the collider. In the Japanese civil law, it is only stated that

the people's right for the lands extends to the space under the surface. It can be extended in principle to the other side of the earth. However, tunnels for the cars and trains have been built with only permission of the land owner above the tunnel without any compensation for using land beneath, if the tunnel is deeper than 30 m from the surface. Of course if something wrong happen, such as the deformation of the surface land or the drying up of the land by sucking up all the water in the surface land into the tunnel, they have been compensated. For the usage of the space down the 30 m, it has to be compensated according to the depth and the feature of the surface status. Therefore in the present studies, it was planned to have the tunnel deeper than 50 m from the surface in the previous designs. For the details, see the reference ***.

8) Supply of the electricity

To have an accelerator, it is important to have the electricity available rather easily. For the Abukuma area, there are many nuclear power stations along the Pacific coast. So the expected electric power of about 150 MW can be supplied.

9) Water drainage and the radiation problem

It is important to keep the tunnel dry. From this view point, it is important to have tunnels through the homogenous hard rock. Because at the fault, there are tremendous amount of the water comeout. At the Shimizu tunnel of the Joetsu line in Gunma prefecture, tons of water come out per hour at the fault and beside the main tunnel people had to build a subsidiary large drainage.

In the present design, the small water drainage is equipped beneath the tunnel floor. The expected water oozed from the rock is estimated to be at most 0.5 ton/km/min. This water is pumped out at the service station.

In this study, careful examination of the radiation problems was not made but we believe that there will be no serious problems on the effects of the radiation to the human being because of the following arguments; The circulation particles are at most 10^{14} which are of the same order of magnitude as that for the Tevatron. Since the circumference is about 17 times larger than that of the Tevatron and the beam energy is about 30 times larger than that of the Tevatron, the amount of the energy lost per meter is only twice as large as that of the Tevatron. If the Tevatron is safe enough, so is the new collider. This argument is quite crude and this problem should be further studied.

10) Conclusion

We studied the construction of an accelerator complex of a hadron collider with the beam energy larger than 30 TeV. The collider is planned by lining about 10000 superconducting magnets through a tunnel under the ground to shield the radiation. The diameter of the tunnel for the main accelerator becomes as large as 30 km. The complex has a booster with the beam energy of one TeV. We found some places into which the accelerator complex can be fit. One possibility

is the area of the Abukuma district of the Fukushima prefecture. The construction cost and time of tunnels were estimated by the experts and it is about 90 B¥ for the whole complex including the approaching roads and tunnels and boosters. This is only three times more than that of the TRISTAN tunnel in spite of the 30 times larger circumference of the accelerator. This is consistent with the estimated cost of the LEP tunnel. The construction can be finished in four years.

国立学校特別会計

(研究所+施設整備費)

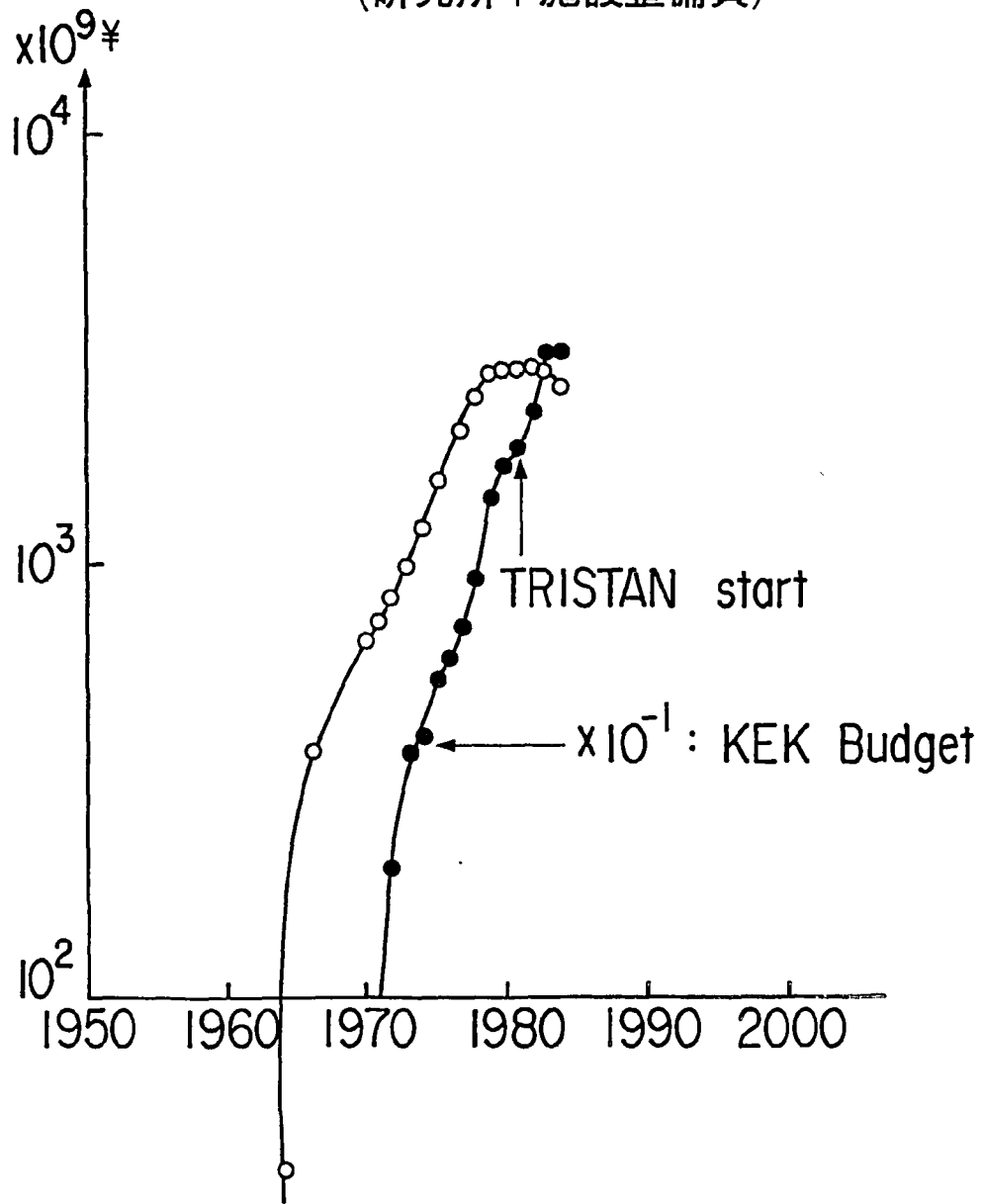

全体平面図

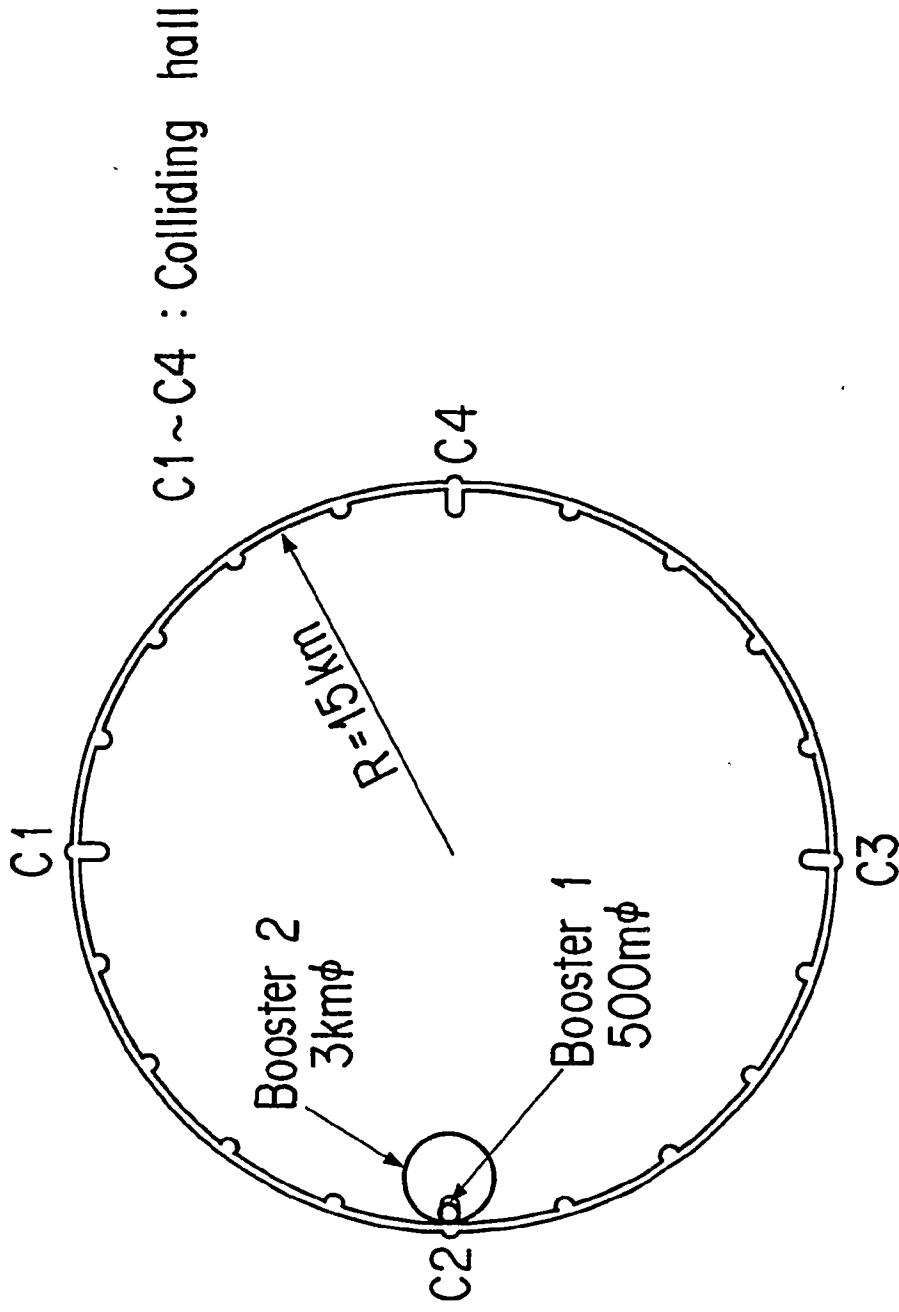



图- 本坑標準断面图

詳細 A



掘削代と土質の関係

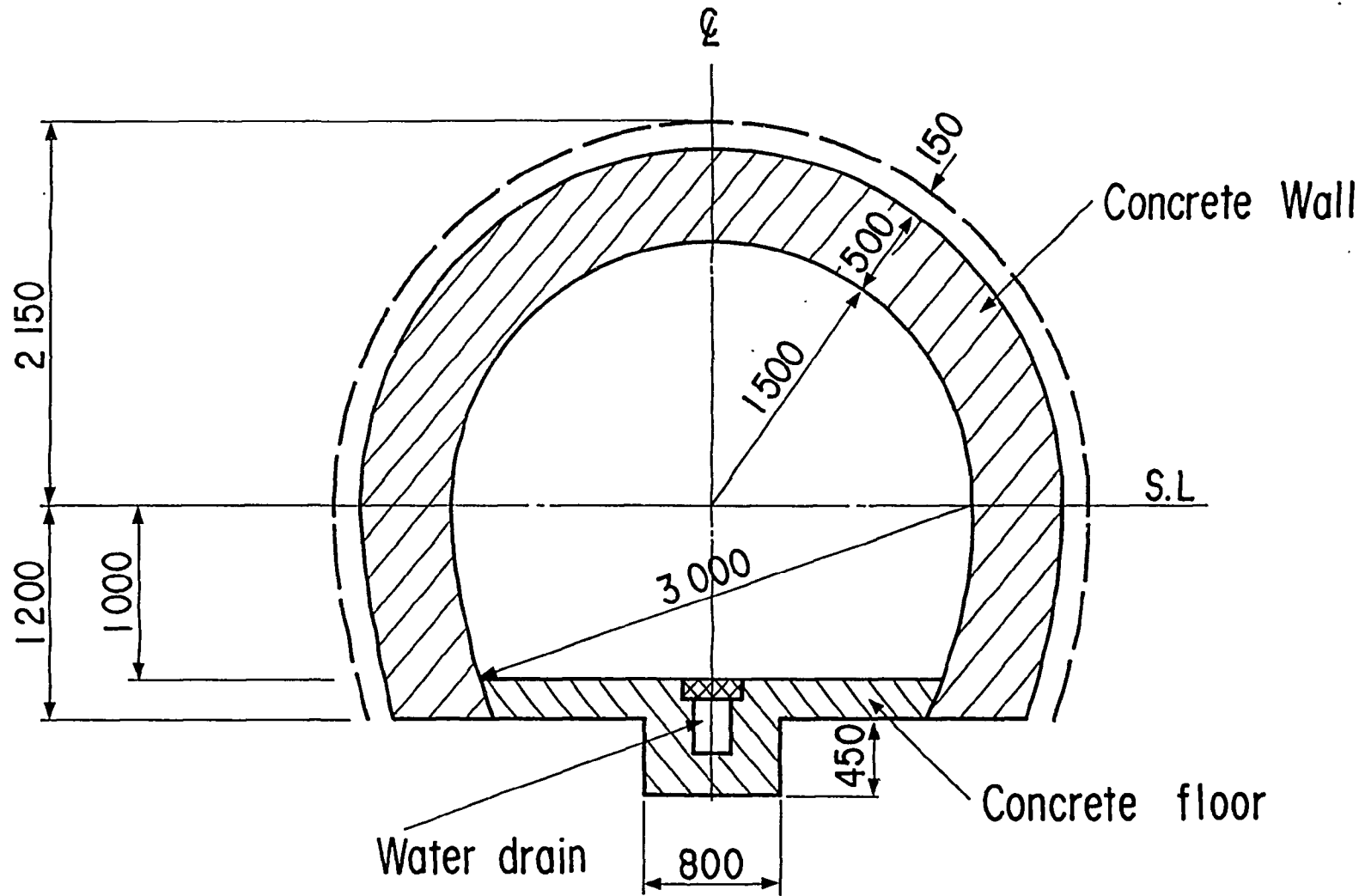
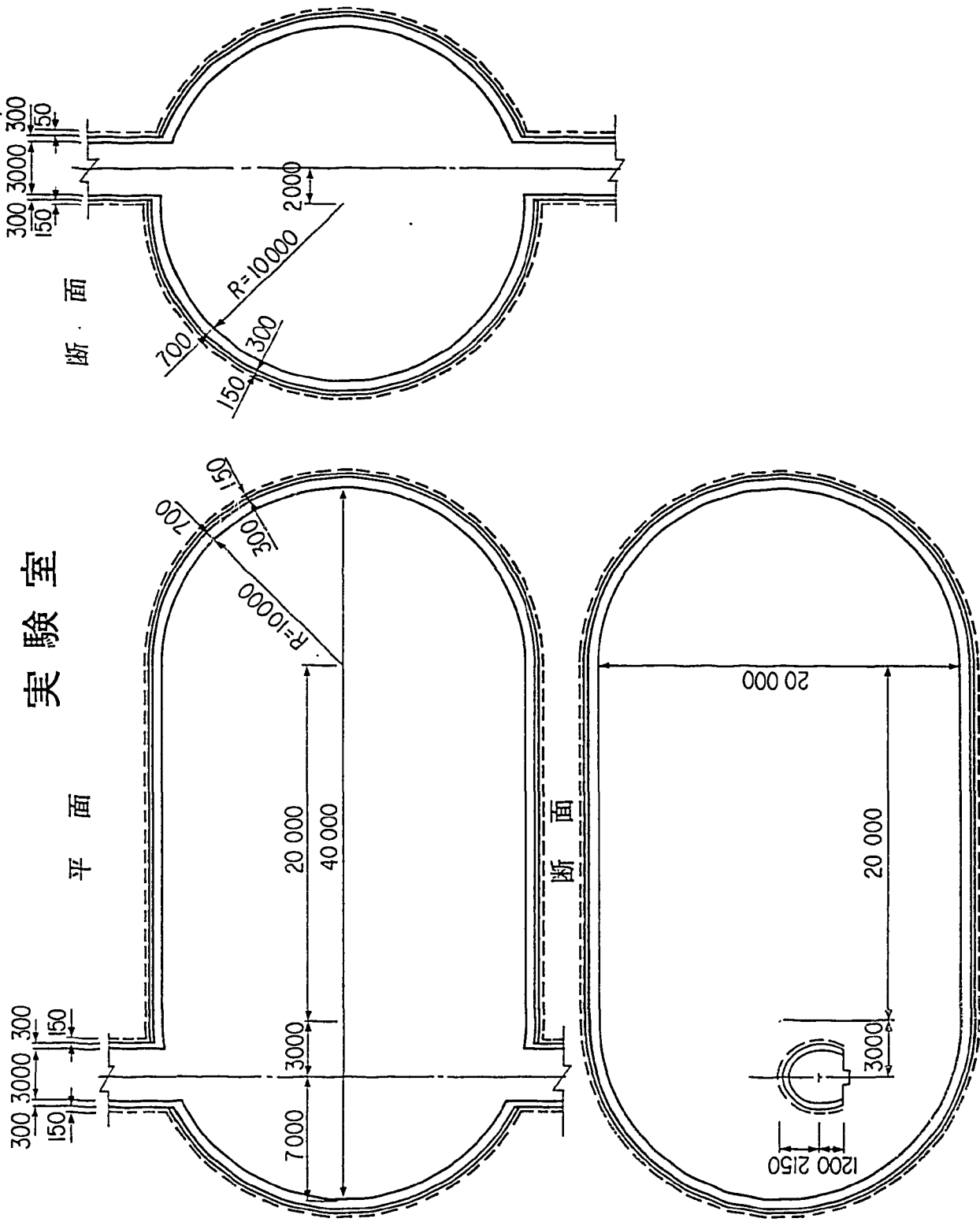
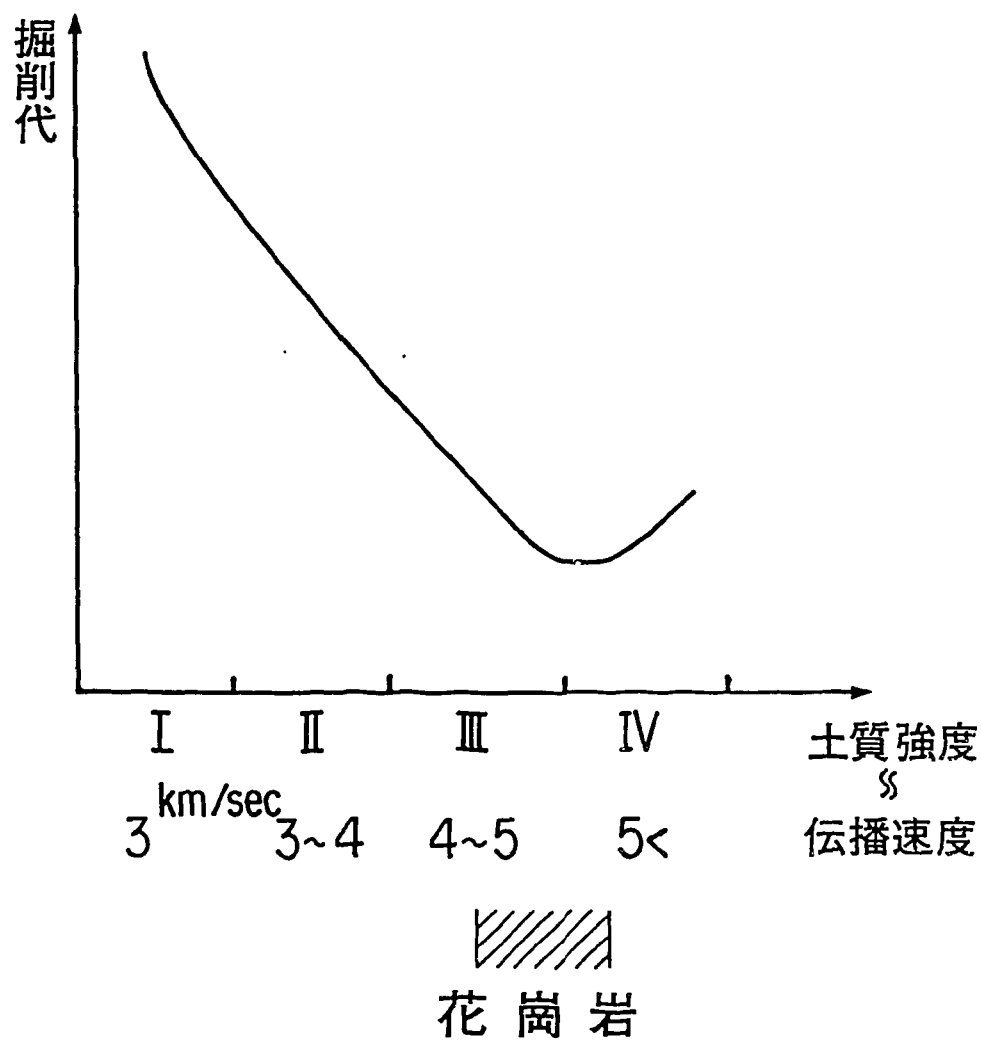

Provisional classification of granitic rocks in the main part of Japan

0 100 200
Kilometers

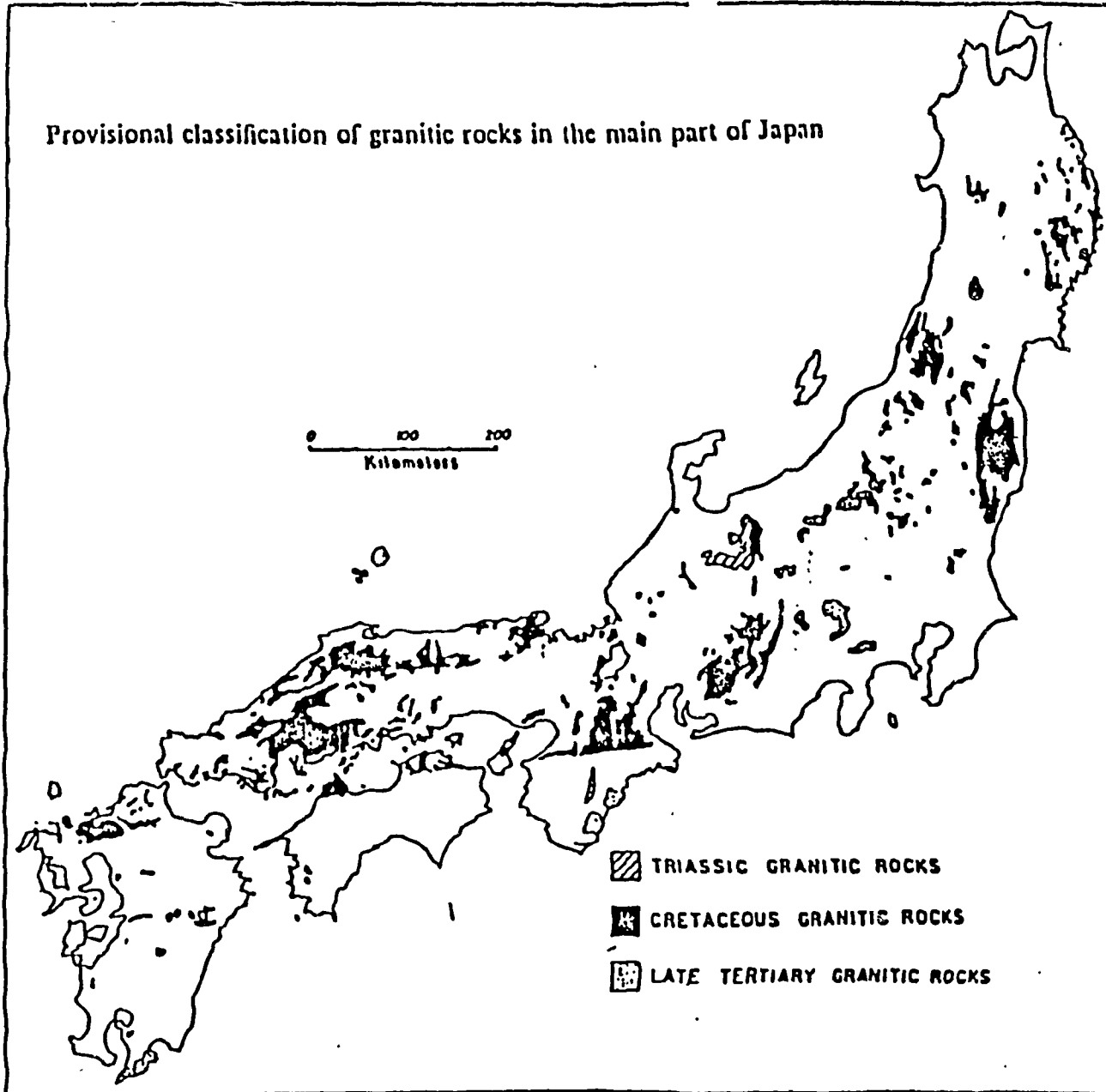

福島案平面図 S = 1 : 250,000

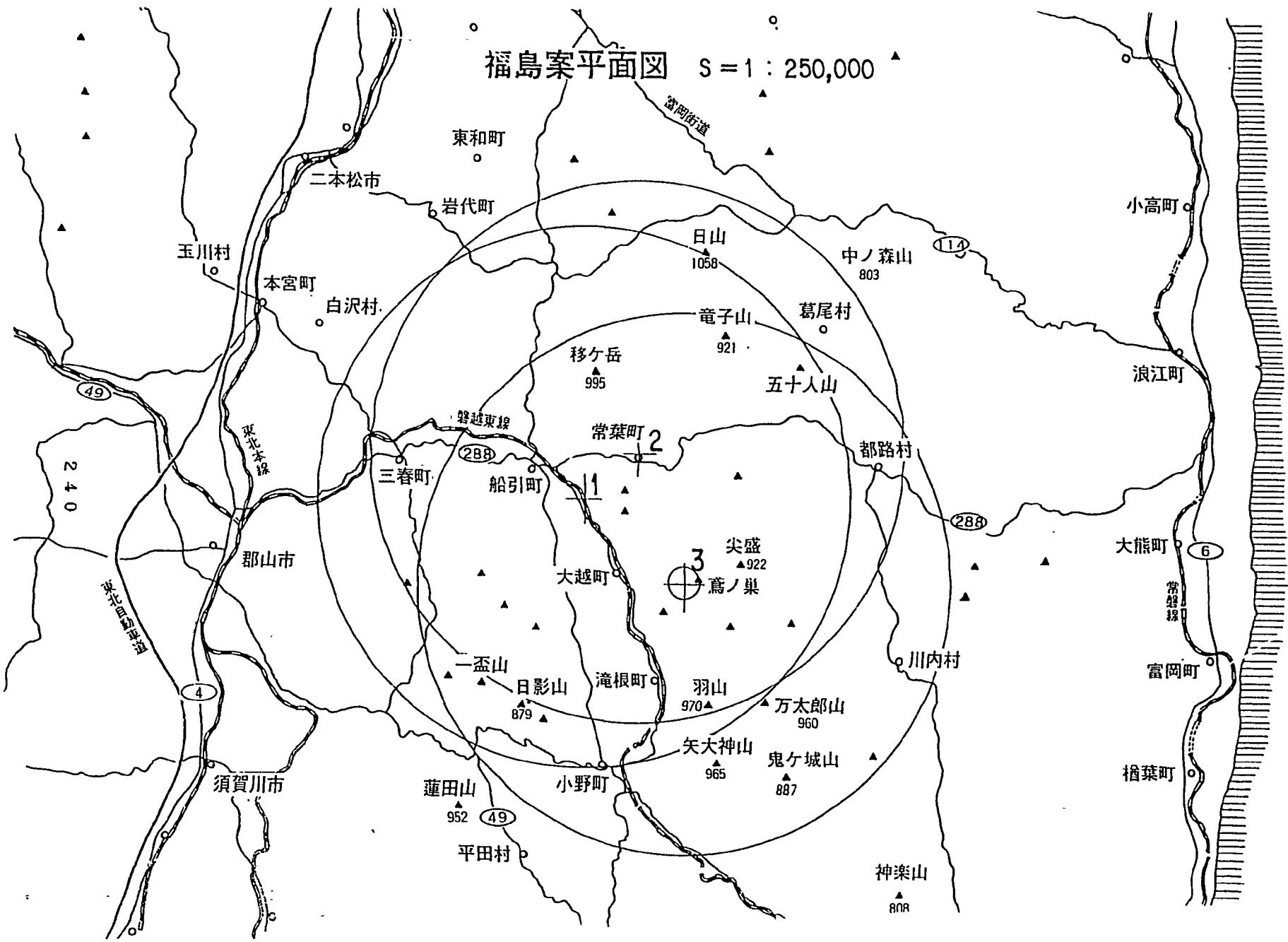

東和町

二本松市

岩代町

日山

中ノ森山

玉川村

本宮町

白沢村

竜子山

葛尾村

移ヶ岳

五十人山

小高町

浪江町

磐越東線

常葉町

都路村

三春町

船引町

大熊町

郡山市

大越町

尖盛

鷲ノ巢

富岡町

一盃山

日影山

滝根町

羽山

万太郎山

川内村

檜葉町

須賀川市

蓮田山

平田村

小野町

矢大神山

鬼ヶ城山

神楽山

240

4

49

288

2

3

288

6

114

富岡街道

阿賀野川

阿賀野川

常磐線

地質縦断図 (福島第3案)

本坑計画高 h=310m

地質分類記号
凡例

記号	名称
Gr(I)	花崗岩
Gr(II)	花崗閃緑岩(古期)
Gr(III)	花崗閃緑岩(新期)

----- 立坑

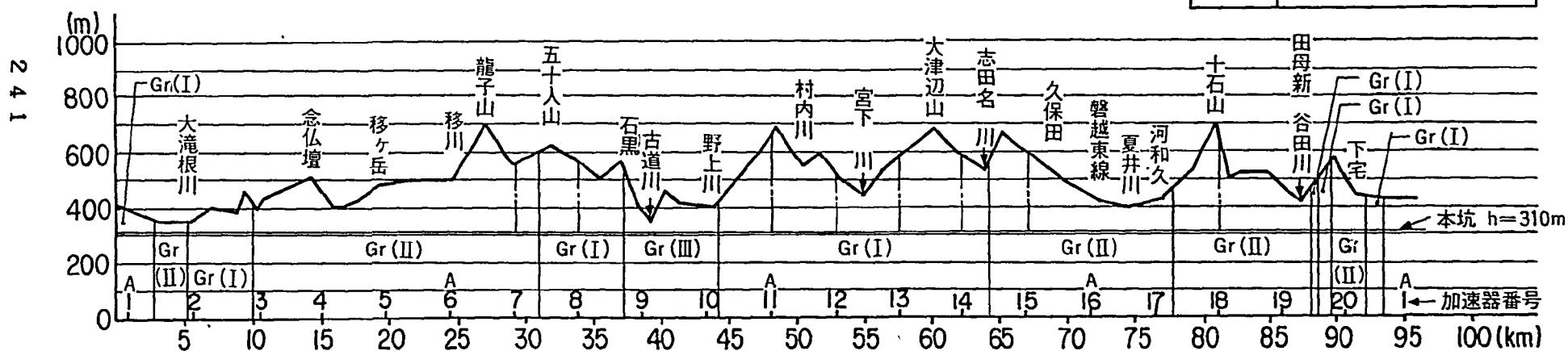

241

筑波案平面図 S=1:200,000

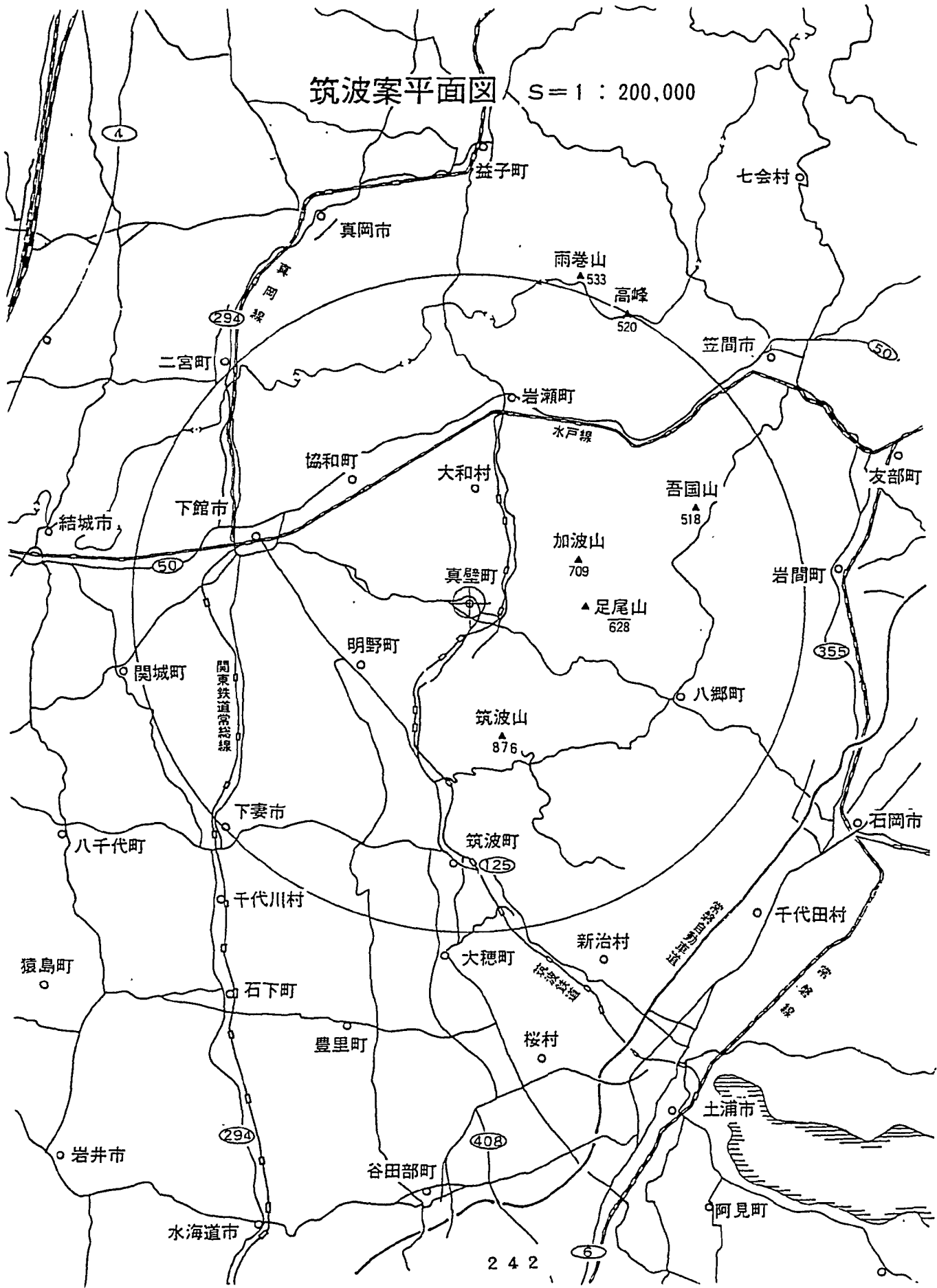

地質縦断図 (茨城案)

地質分類記号
凡例

記号	名称
S	砂
m	泥
mS	泥岩
SS	砂岩
Gr ₄	斑状黒雲母花崗岩 筑波型 両雲母花崗岩 花崗岩
Gr ₅	黒雲母花崗岩
Bs	黒色片岩
Hr	ホルンフェンス
So	片麻岩
L	ローム

