

UCRL--15809

DE86 010557

INSTRUMENTATION PROGRAM  
FOR  
ROCK MECHANICS AND SPENT FUEL TESTS  
AT THE NEVADA TEST SITE

By

H. R. Pratt  
W. H. Hustrulid  
R. Simonson

Submitted To

Lawrence Livermore Laboratory  
Livermore, California

Terra Tek, Inc.  
Salt Lake City, Utah  
August, 1978  
TR78-48

DISCLAIMER

This report was prepared as an account of work sponsored by an agency of the United States Government. Neither the United States Government nor any agency thereof, nor any of their employees, makes any warranty, express or implied, or assumes any legal liability or responsibility for the accuracy, completeness, or usefulness of any information, apparatus, product, or process disclosed, or represents that its use would not infringe privately owned rights. Reference herein to any specific commercial product, process, or service by trade name, trademark, manufacturer, or otherwise does not necessarily constitute or imply its endorsement, recommendation, or favoring by the United States Government or any agency thereof. The views and opinions of authors expressed herein do not necessarily state or reflect those of the United States Government or any agency thereof.

**MASTER**

DISTRIBUTION OF THIS DOCUMENT IS UNLIMITED

*Law*

TABLE OF CONTENTS

INTRODUCTION . . . . .	1
FULL SCALE HEATER TESTS. . . . .	4
Introduction. . . . .	4
Instrumentation Layout. . . . .	5
Testing Procedure . . . . .	.22
SPENT FUEL FACILITY. . . . .	.25
Introduction. . . . .	.25
Excavation Schedule . . . . .	.25
Rock Mass Instrumentation Program . . . . .	.29
Purpose of Measurements. . . . .	.29
Excavation Procedure . . . . .	.29
Types of Measurements. . . . .	.30
Location of Instrumentation. . . . .	.30
Spent Fuel Drift Instrumentation Program. . . . .	.37
Purpose of the Measurements. . . . .	.37
Instrumentation Layout . . . . .	.37
HEATED ROOM EVALUATION . . . . .	.45
Introduction. . . . .	.45
Room Stability Evaluation . . . . .	.45
Analysis of the Proposed Pillar Experiment. . . . .	.46
ROCK MECHANICS INVESTIGATIONS. . . . .	.49
<i>In Situ</i> Measurements. . . . .	.49
Laboratory Measurements . . . . .	.54
EXCAVATION TECHNIQUES. . . . .	.55
DRILLING SPECIFICATIONS FOR HEATER AND INSTRUMENT BOREHOLES. . . . .	.56

RECOMMENDED BOREHOLE AND DRIFT INSTRUMENTATION . . . . .	.57
Borehole Instrumentation . . . . .	.57
Thermocouples . . . . .	.57
Extensometer . . . . .	.57
USBM Borehole Deformation Gage . . . . .	.58
The Vibrating Wire Stressmeter . . . . .	.61
Drift Instrumentation . . . . .	.62
Delivery Schedule and Costs . . . . .	.63
DATA ACQUISITION AND REDUCTION REQUIREMENTS . . . . .	.65
Extensometer . . . . .	.65
USBM Gage . . . . .	.67
Vibrating Wire Stressmeters . . . . .	.69
Thermocouples . . . . .	.71

TABLES

Table 1. Summary of Hole and Instrumentation Requirements  
Per Experiment in Climax Stock Granodiorite. . . . .21

FIGURES

Figure 1. Plan View For Heater Experiment. . . . .	8
Figure 2. Heater and Thermocouple Gages and Hole Location. . . . .	9
Figure 3. Monitor/Geophysical Holes Location . . . . .	10
Figure 4. Plan Location of USBM/IRAD Holes and Gages From Heater Drift . .11	
Figure 5. USBM/IRAD Gages. . . . .	12
Figure 6. Extensometer Holes Locations . . . . .	13
Figure 7. Vertical Section Through Heater Drift Showing Extensometer . . .14	
Figure 8. Vertical Section Through Heater Drift Showing Extensometer Anchor Positions . . . . .	15
Figure 9. Hole Level From Extensometer Drift . . . . .	16
Figure 10. Location of USBM Gages Installed From Extensometer Drift . . . .17	
Figure 11. Location of IRAD Gages Installed From Extensometer Drift . . . .18	
Figure 12. Location of Horizontal Anchors, Level 1. . . . .	19
Figure 13. Location of Horizontal Anchors, Level 3. . . . .	20
Figure 14. Heater Tests, Power Level Versus Time. . . . .	23
Figure 15. Heater Tests, Power Level Versus Time. . . . .	24
Figure 16. Underground Layout of Spent Fuel Test. . . . .	26
Figure 17. Section View of the Heater/Canister Holes. . . . .	27
Figure 18. Section View Through the Spent Fuel Facility . . . . .	33
Figure 19. Section View Through the Spent Fuel Facility . . . . .	34
Figure 20. Section View Through the Spent Fuel Facility . . . . .	35
Figure 21. Section View Through the Spent Fuel Facility . . . . .	36
Figure 22. Underground Layout of Spent Fuel Test. . . . .	39
Figure 23. Representation of the Canister Holes in the Canister Drift . . .40	
Figure 24. Plan Location of Monitor/Thermocouple Holes. . . . .	41
Figure 25. Plan Location of Monitor/Thermocouple Holes. . . . .	42

Figure 26. Plan View of Monitor/Thermocouple Holes in the Canister Storage Drift. . . . .	.43
Figure 27. Location of the Extensometer Holes in the Canister Storage Drift. . . . .	.44
Figure 28. CSM Cell System. . . . .	.51
Figure 29. Flatjack Experiment. . . . .	.52
Figure 30. Schematic Drawing of Rod Extensometer. . . . .	.59
Figure 31. USBM Deformation Gage. . . . .	.60
Figure 32. Vibrating Wire Stressmeter . . . . .	.61
Figure 33. Cubic Spline Approximation to the Temperature Gradient as Determined by the Five Temperatures . . . . .	.66
Figure 34. Calibration Curves as a Function of Temperature for the USBM Gage. . . . .	.67
Figure 35. Displacements Measured by USBM Gages . . . . .	.68
Figure 36. Typical Calibration Curves for Vibrating Wire Stressmeters . . . . .	.69

## INTRODUCTION

This report contains a discussion of an instrumentation and rock mechanics program recommended for consideration as part of the overall Lawrence Livermore Laboratories nuclear waste storage program at NTS. It includes a discussion of (1) rationale for the heater tests, spent fuel facility evaluation, heated room tests, (2) recommended instrumentation types together with estimated delivery schedules, (3) recommended instrumentation layouts, (4) other proposed rock mechanics tests both laboratory and *in situ*, and (5) data acquisition and reduction requirements.

The basic objectives of the geotechnical evaluation of potential sites for the storing/disposal of radioactive waste is summed up in the word "containment." This means selecting a repository which will isolate the contained material from the biosphere for a period of time sufficiently long enough to prevent any adverse effects to man. This requires:

1. evaluating the site containment potential prior to major construction,
2. evaluating and minimizing the effect of construction on the containment,
3. evaluating and keeping to an acceptable level, the (short and long term) adverse effect of the emplaced waste on site containment.

Although it is understood that the present NTS site in granite is not being considered for an actual repository, the site evaluation techniques and procedures developed and applied would provide the basic understanding necessary for proper future site selection and monitoring.

It should be kept firmly in mind that the rock mass which is involved is extremely complex. It cannot, in general, be classified as a homogenous, isotropic body except perhaps for evaluating very large scale effects. Even then, the true "average" properties can differ greatly from those measured in the laboratory and even from moderately large *in situ* tests. The rock can be extremely variable in itself.

Superimposed upon this is the rock mass structure which includes joints, faults, and the *in situ* stress field. Finally, thermomechanical fields from radioactive source is added to the loading of the rock mass; hence, the types, numbers and locations of the instruments chosen depends upon a number of factors, some of which are:

1. computer simulation results,
2. practical operational considerations,
3. sensitivities, accuracies, and operating limitation of the instruments,
4. need for redundancy presuming some instrument failure, and
5. quality assurance of the generated data, keeping in mind the variability of the rock mass.

Although recommendations are given in this report, it must be emphasized that the generation of a final instrumentation layout requires a considerable amount of interaction between instrumentation specialists and modelers. Time limitations have not allowed for such interaction to take place at this point.

While there are certain similarities between this program and the geo-mechanics programs presently underway at Stripa and proposed for Hanford, Washington, there are some notable differences. The first and perhaps the most significant is that of performing multiple heater tests at a variety of



power levels at a well instrumented site. Another is that no time-scaled test is recommended since it is felt that such information will be forthcoming from the two other experiments. For the spent fuel facility, a site evaluation and monitoring program (based on the present state-of-the-art) similar to what might be practical for an actual repository is suggested. The instrumentation types recommended for use are those which are available and historically used for making the desired measurements. Although some tools have been extensively modified to withstand the severe environmental conditions, they remain in the basic form. It is hoped that time (and budget) will be such as to allow the design, development and evaluation of new instrumentation. Monitor holes and extra holes should be available for incorporating such instruments at later stages in the program.

It is the opinion of the writers that a minimum of two representative heater sites be chosen for these experiments and that they be fully instrumented. This is considered to be superior to performing more experiments, but with a fraction of the instrumentation. The variability of the rock and the probability of rock failure requires close-in measurement during the heating process. One requires a program which provides conclusive results, not one which raises more questions than it answers.

## FULL SCALE HEATER TESTS

### Introduction

The effect of thermal loading imposed by a waste canister in the surrounding rock can be studied over relatively short time periods using electrical heaters having geometries and heating capabilities similar to those expected in practice. The effects of the thermal loading are to alter (1) the stress, displacement and temperature fields, and (2) the strength and thermal properties of the rock. Pre-test site evaluation, test monitoring and post-test site evaluation programs should be designed to determine these effects and the rock response.

The measured temperature, displacement and stress fields can be compared with those predicted using thermomechanical models. The input parameters assumed for the model such as deformation modulus, conductivity, etc. can then be varied so that agreement is good over the time period of data collection. We would like to use these models to predict effects hundreds of thousands of years in the future. The validity of making such predictions is open to serious question, particularly if the experimental data base is small and considerable scatter exists. Even if the basic form of the time dependence is correct, a small error in the time constant could markedly effect the predictions. One way of extending the time period for data collection is to perform a time-scaled experiment. Such an experiment is being conducted in Sweden and is planned for Hanford. Both have time scaling factors of about 10, hence, tests run for two years would provide indications of what would occur during 20 years of operation. The time scaled results from Sweden and Hanford will hopefully be applicable to the NTS granite and therefore another such experiment is probably not required. Other than a time-scaled test, the only other way of obtaining long term data is from a long term test. It is obvious that time constraints will not allow an extended practice period before actual waste is employed. During the data

collection period (possibly 50 to 100 years), retrievability of the waste will be required. This restriction will have sufficient impact on the form of the container, the form and age of the waste, and the stability requirements for the openings.

### Instrumentation Layout

The full scale test has been laid out to allow for a three dimensional definition of the thermal, stress and deformation fields. A three dimensional view of the thermal field can be obtained by placing thermocouples at various depths in holes drilled parallel to the heater hole and at various radial distances from it. Unfortunately, the same does not apply for obtaining the stress and deformation fields. If the heater is assumed to be along the (z) (vertical) axis, then "stress" measuring devices placed in holes having a (z) orientation, would measure stress changes in the horizontal plane.

Displacement devices such as extensometers placed in (z) oriented holes would provide the vertical displacement component. To obtain the other components of the stress and deformation fields, it is proposed that both a heater drift from which the heater and a majority of instrumentation is installed and an extensometer drift (parallel to the heater drift, but at lower elevation) be driven. Instrumentation to monitor deformation in the plane normal to the axis of the heater and stress changes in the vertical plane would be installed from the extensometer drift. The advantages of the dual drift layout compared to the single are:

1. only vertical and horizontal (or near horizontal) holes be drilled, (simplified drilling),
2. simplified data interpretation,
3. simplified visualization of the measurement program,
4. provides an opportunity for geotechnical mapping of the rock volume,

5. provides much more experimental flexibility, and
6. provides an additional drift where *in situ* rock mechanics, roof tests, etc. could be conducted.

It has the disadvantage of increased excavation expense.

It is possible, in theory, to obtain such measurements without the use of the extensometer drift. Several such possibilities were evaluated during the design of the Stripa project. To obtain the required deformations, for example, deflectometers could be used. The cost per anchor point was high; the down hole electronics would not withstand high temperature, the instrument sensitivity was not sufficient, and calibration/thermal correction difficult. There are some stress change gages which purportedly will provide a three dimensional stress change picture using one hole. These devices consist of a large number of strain gages mounted at various orientations in an epoxy plug. This plug must be grouted into the hole. To date, there has been very little information available about this gage and no results reported of using this type of gage under thermal loading conditions. It is suspected that thermal creep of the epoxy as well as lack of temperature compensation of the strain gages will make meaningful interpretation difficult if not impossible without significant development.

Stress changes in the vertical (z) direction and displacement changes in the horizontal plane (x and y directions) can also be obtained by the use of usual instruments installed in holes drilled from the heater drift, but inclined at some angle to the (z) direction. For example, the total measurement has to be resolved into components. The value is a function of the sine of the angle between the hole axis and the vertical. Thus, the angle would have to be greater than  $45^{\circ}$  for the desired component to be the largest.

Interpretation of these measurements require the assumption of anisotropy which may or may not be valid. Furthermore, it is rather difficult to control the orientation of such angled holes. For these reasons, the best alternative is considered to be that of driving a horizontal drift parallel to the heater drift and at the elevation of the heater element. The instrumentation layout described on the following pages has been made on this basis (see Figures 1-13).

ZONE	LTR	DESCRIPTION	DATE	APPROVED
------	-----	-------------	------	----------

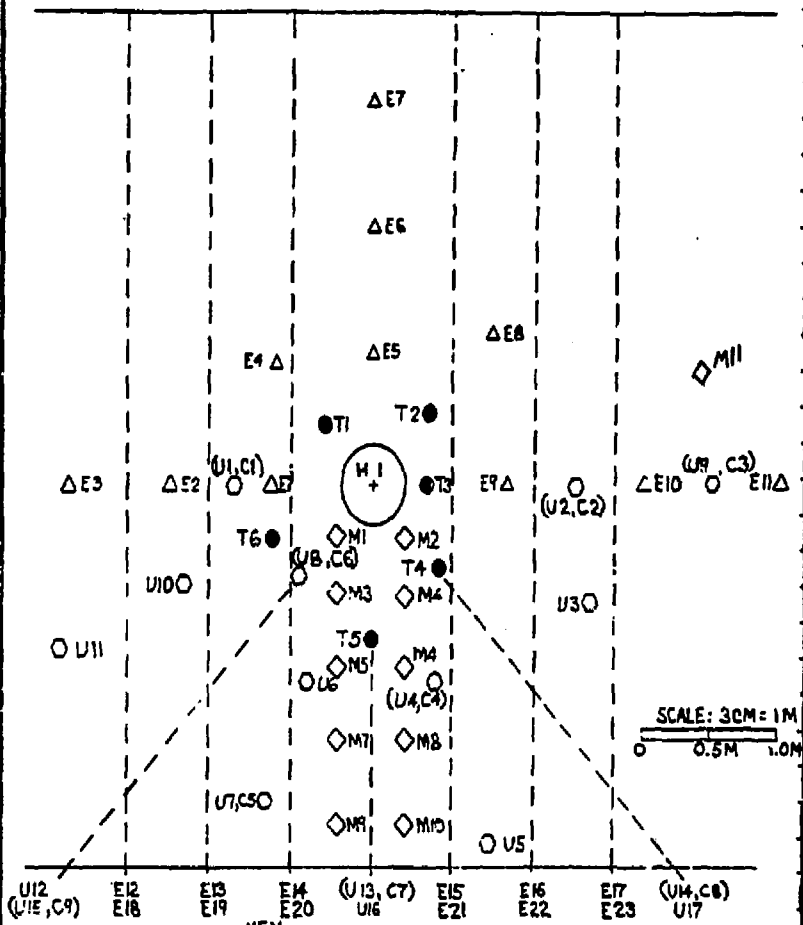

KEY:

○	H HEATER, 460 MM DIA.
●	T THERMOCOUPLE, 38 MM DIA.
◇	M MONITOR / GEOPHYSICAL, 56 MM DIA.
○	UC USEM, IRAD GAGE 38 MM DIA.
△	E EXTENSOMETER, 76MM DIA. REAMED TO 100MM DIA. 1M DEEP.
---	HORIZONTAL DRILLED HOLES

ITEM	QTY	NOMENCLATURE OR DESCRIPTION	PART OR IDENTIFYING NO.	SPECIFICATION	MATERIALS OR NOTES
------	-----	-----------------------------	-------------------------	---------------	--------------------

LIST OF MATERIALS OR PARTS LIST

APPROVED	DATE
ENGINEER <i>W. Huxford</i>	8-16-78
CHECKER <i>Richard Smith</i>	8-16-78
DRAWN <i>LARRY PHILLIPS</i>	8-7-78

**TerraTek**

UNLESS OTHERWISE SPECIFIED DIMENSIONS SHALL FALL WITHIN THE TOLERANCE LIMITS LISTED BELOW

FIG: 1 PLAN VIEW FOR HEATER EXPERIMENT

1-(U-C)-TWO GAGES IN SAME HOLE.

BASIC DIM	FRACTIONS	TWO DEC	BASIC DIM	DECIMALS	ANGLE	REV
UNDER 5"	1/16"	0.015"	UNDER 1/8"	0.001"	A	
5" TO 24"	1/32"	0.031"	1/8" TO 1/4"	0.002"	325048	
OVER 24"	1/16"	0.062"	1/4" TO 1/2"	0.003"		
ANGLES 90°			OVER 1/2"	0.005"		

NOTES:

SCALE	1/4" = 1 M	DATE	8-16-78	SHEET	1 OF 4
-------	------------	------	---------	-------	--------

3

2

1

ZONE	LTR	DESCRIPTION	DATE	APPROVED
------	-----	-------------	------	----------

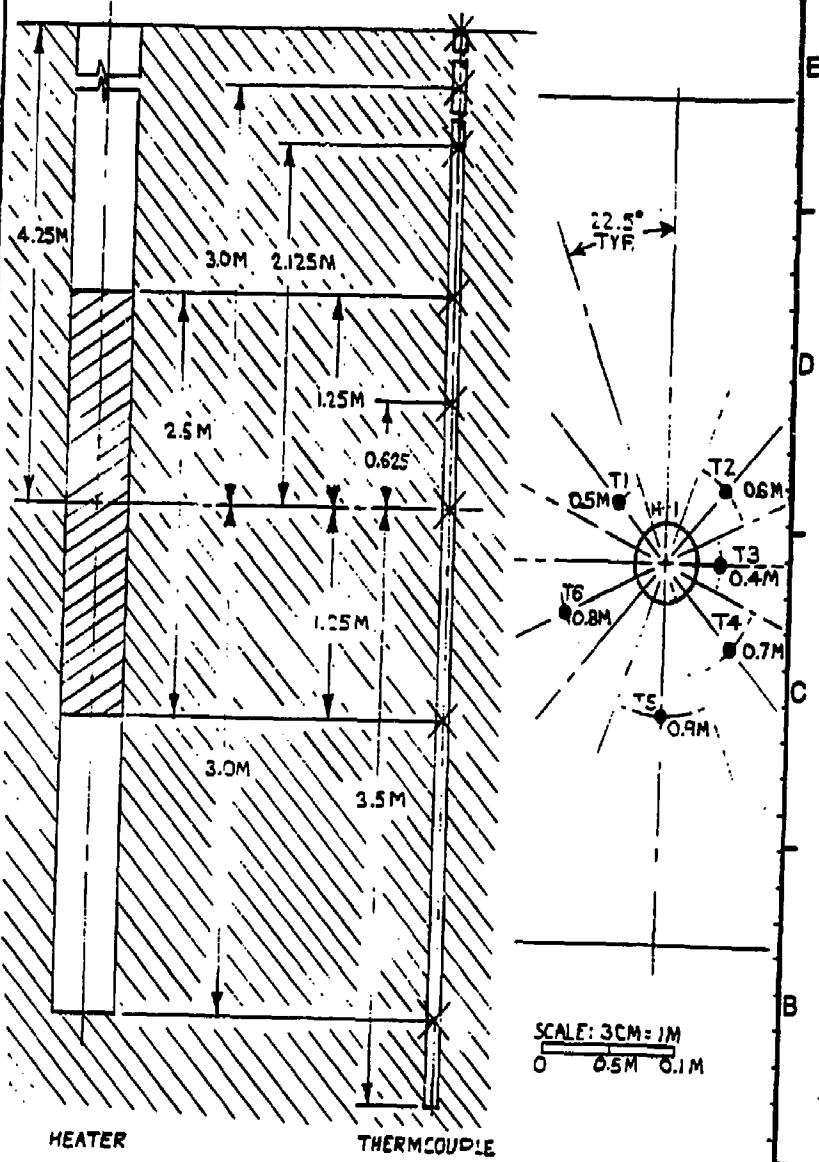

HEATER

THERMOCOUPLE

SCALE: 3CM = 1M  
0 0.5M 0.1M

APPROVED	DATE
ENGINEER <i>W. Huestwald</i>	8-16-78
CHECKED <i>R. Phillips</i>	8-8-78
DRAWN <i>Abby R. Phillips</i>	8-8-78
UNLESS OTHERWISE SPECIFIED DIMENSIONS SHALL FALL WITHIN THE TOLERANCE LIMITS LISTED BELOW	
BASIC DIM	DECIMAL
FRAC	FRACTION
FINISH	FINISH
AS-BUILT	AS-BUILT
1" TO 1/4"	± 0.005
1/4" TO 1"	± 0.002
OVER 1"	± 0.001
ANGLE 90°	± 1.0

**TerraTek**

FIG.2 HEATER & THERMOCOUPLE GAGES & HOLE LOCATION

SIZE **A** 325049

SCALE RA SHEET C







ZONE	LTR	DESCRIPTION	DATE	APPROVED
------	-----	-------------	------	----------

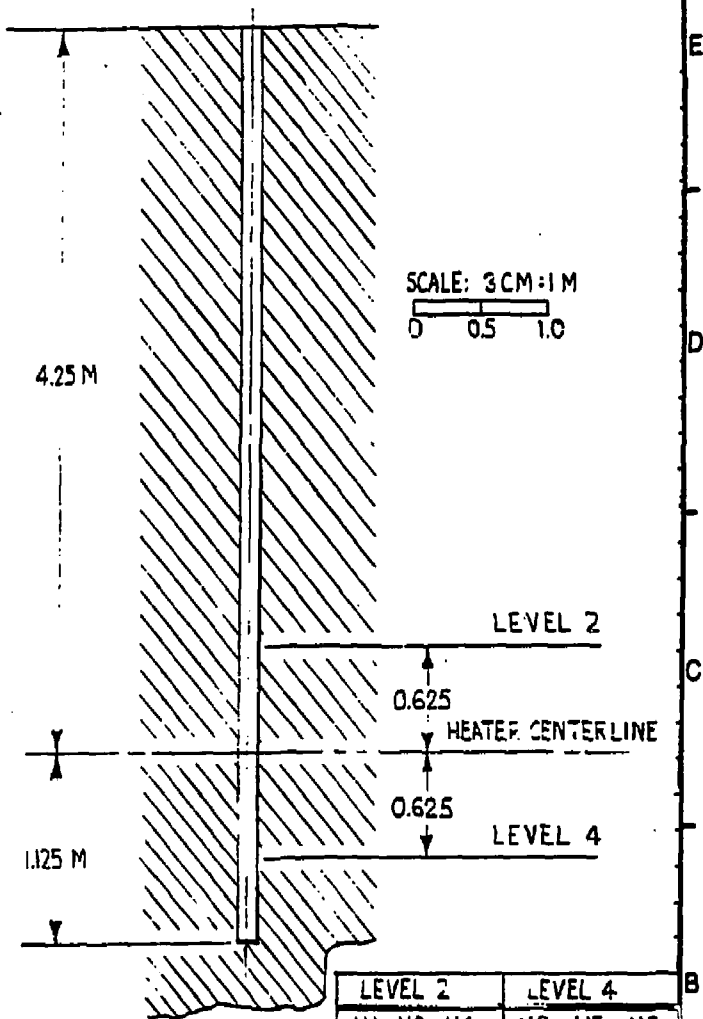

LEVEL 2	LEVEL 4
U1, U2, U4, U7, U8, U9	U3, U5, U6, U10, U11
	C1, C2, C3, C4, C5, C6

ITEM	QTY	NOMENCLATURE OR DESCRIPTION	PART OR IDENTIFYING NO	SPECIFICATION	MATERIALS OR NOTES
LIST OF MATERIALS OR PARTS LIST					
APPROVED		DATE			
DRAWN BY		DATE			
CHECKED BY		DATE			
DESIGNED BY		DATE			
UNLESS OTHERWISE SPECIFIED DIMENSIONS SHALL FALL WITHIN THE TOLERANCE LIMITS LISTED BELOW:					
BASIC DIM	PRECISION	FRACTION	TOLERANCE	BASIC DIM	TOLERANCE
LENGTH	± 0.13	1/32	± 0.0015	ANGLE	± 0.0015
WIDTH	± 0.13	1/32	± 0.0015	RADIUS	± 0.0015
DIAMETER	± 0.13	1/32	± 0.0015	DEPTH	± 0.0015
THICKNESS	± 0.13	1/32	± 0.0015	CHAMFER	± 0.0015
POSITION	± 0.13	1/32	± 0.0015	SPACING	± 0.0015
DRILL	± 0.13	1/32	± 0.0015	FINISH	± 0.0015
PLUG	± 0.13	1/32	± 0.0015	COATING	± 0.0015
WELD	± 0.13	1/32	± 0.0015	OTHER	± 0.0015
ASSEMBLY	± 0.13	1/32	± 0.0015		

**TomTek**

FIG. 5 USBM / IRAD GAGES

A	325052	REV

ZONE	LTR	DESCRIPTION	DATE	APPROVED
------	-----	-------------	------	----------

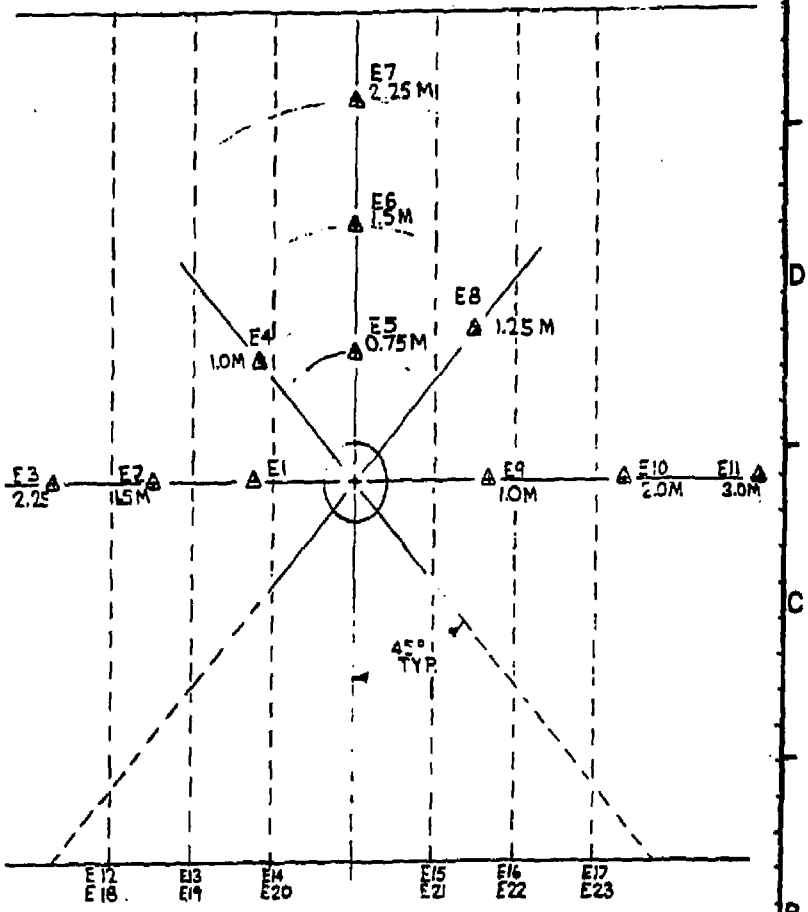

SCALE: 3CM=1M  
 0 0.5M 1.0M

ITEM	QTY	NOMENCLATURE OR DESCRIPTION	PART OR IDENTIFYING NO	SPECIFICATION	MATERIALS OR NOTES
LIST OF MATERIALS OR PARTS LIST					
APPROVED		DATE	<b>TerraTek</b>		
DESIGNED	<i>W. Huettenlo</i>	8-6-78			
CHECKED	<i>R. Lamb</i>	9-16-78			
DRAWN	<i>Larry R. Phillips</i>	8-8-78			
UNLESS OTHERWISE SPECIFIED DIMENSIONS SHALL FALL WITHIN THE TOLERANCE LIMITS LISTED BELOW					
BASIC DIM		±.00075	BASIC DIM		±.00075
FINISH DIM		±.0015	FINISH DIM		±.0015
LENGTH	±.001	±.001	±.001	±.001	±.001
WIDTH	±.001	±.001	±.001	±.001	±.001
DIAMETER	±.001	±.001	±.001	±.001	±.001
ANGLE	±.001	±.001	±.001	±.001	±.001
SCALE			A		325053
SHEET			OF		

ZONE	LTR	DESCRIPTION	DATE	APPROVED
------	-----	-------------	------	----------

HEATER DRIFT SHOWING EXTENSOMETER ANCHOR POSITIONS

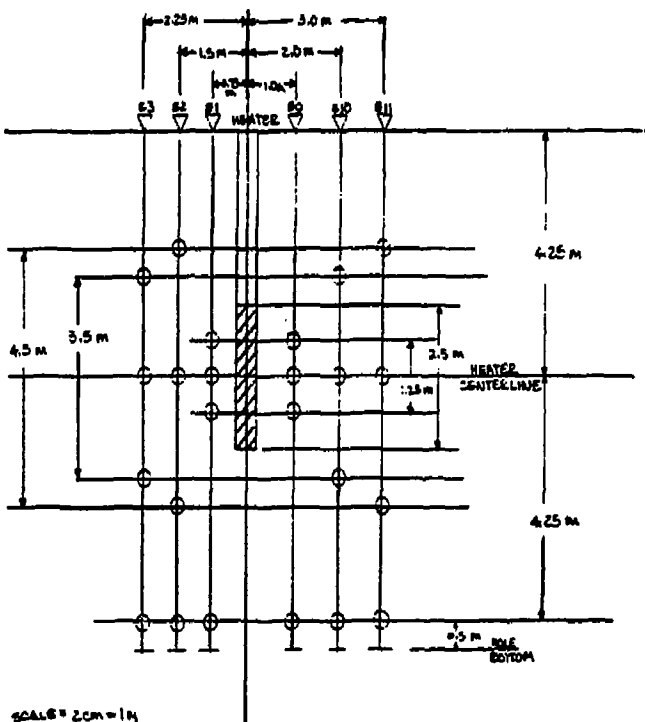

SCALE = 2 CM = 1 M

ITEM	QTY	NOMENCLATURE OR DESCRIPTION	PART OR IDENTIFYING NO	SPECIFICATION	MATERIALS OR NOTES
LIST OF MATERIALS OR PARTS LIST					
APPROVED		DATE			
ENGINEER		8-16-78			
CHECKED		9-16-78			
DRAWN		10/1/78			
UNLESS OTHERWISE SPECIFIED DIMENSIONS SHALL FOLLOW					
WITHIN THE TOLERANCE LIMITS LISTED BELOW					
BASIC DIM	PRECISION	FRACTION	DECIMAL	BASIC DIM	PRECISION
LENGTH	± .001	± .001	± .001	LENGTH	± .001
Ø TO 2"	± .001	± .001	± .001	Ø TO 2"	± .001
OVER 2"	± .001	± .001	± .001	OVER 2"	± .001
ANGLES	± .001	± .001	± .001	ANGLES	± .001
TERRATEK		Fig. 1 Vertical section through heater drift showing extensometer anchor positions.			
325054		REV			
SCALE		RA		SHEET OF	

ZONE	LTR	DESCRIPTION	DATE	APPROVED
------	-----	-------------	------	----------

HEATER DRIFT SHOWING EXTENSOMETER ANCHOR LOCATIONS

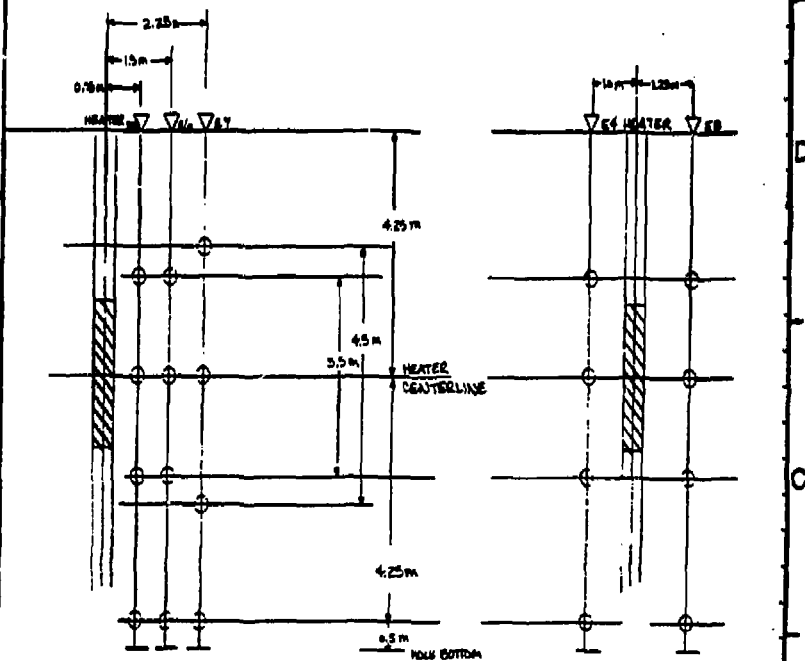

ITEM	QTY	NOMENCLATURE OR DESCRIPTION	PART OR IDENTIFYING NO	SPECIFICATION	MATERIALS OR NOTES
LIST OF MATERIALS OR PARTS LIST					
APPROVED			DATE		
ENGINEER <i>W. Husted</i>			8-16-78		
CHECKED <i>R. Singh</i>			8-16-78		
DRAWN <i>C. A.</i>			8/17/78		
UNLESS OTHERWISE SPECIFIED DIMENSIONS SHALL FALL WITHIN THE TOLERANCE LIMITS LISTED BELOW					
BASIC DIM	FRACTIONAL DECIMAL	FRACTIONAL TOL	BASIC DIM	DECIMAL TOL	SIZE
UNDER 1"	1/32	± 0.015	UNDER 1/8"	0.004	1/8"
1" TO 2"	1/16	± 0.010	1/8" TO 1/4"	0.005	1/4"
OVER 2"	1/8	± 0.010	OVER 1/4"	0.006	3/4"
ANGLES 90°					
TerraTek			Fig. 8 Vertical section through heater drift showing extensometer anchor positions.		
B			325055		
SCALE			R.A.		
SHEET			OF		

7m HEIGHT OVER THE HEATER SO THAT HEATER CAN BE REMOVED FROM THE HOLE ASSEMBLED

ZONE	LTR	DESCRIPTION	DATE	APPROVED
------	-----	-------------	------	----------

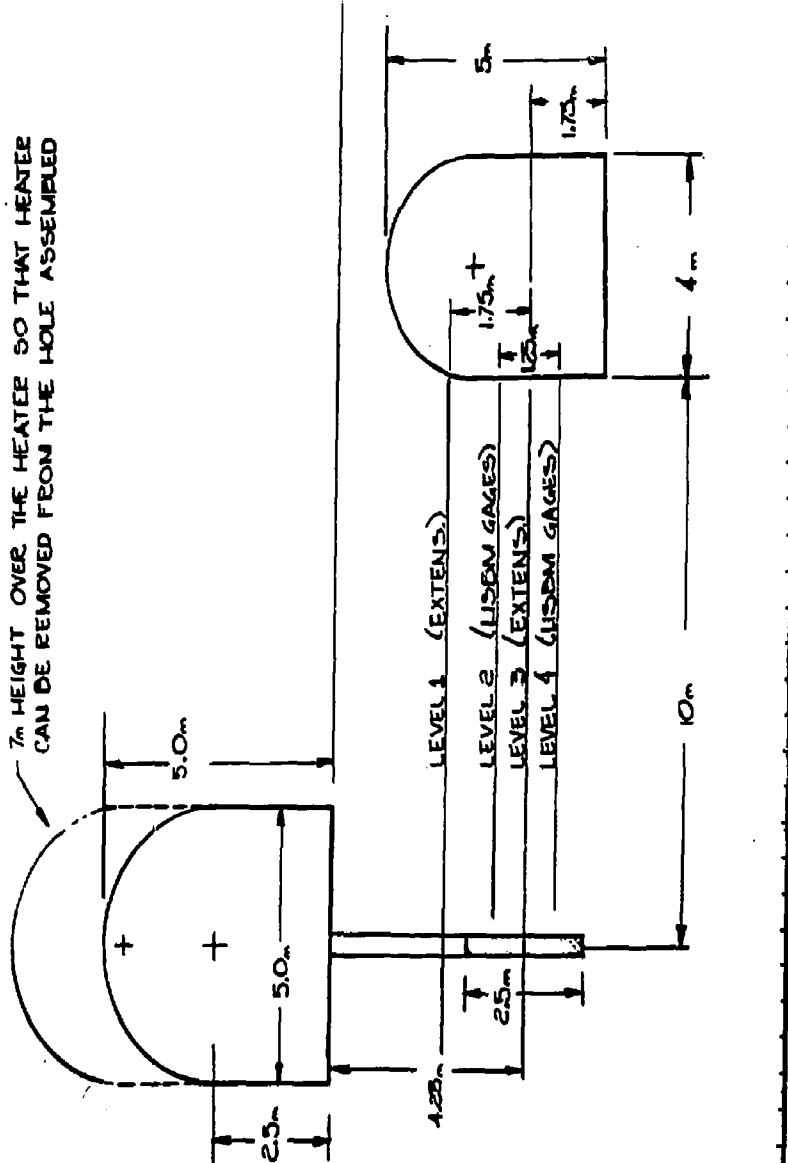

ITEM	QTY	NOMENCLATURE OR DESCRIPTION	PART OR IDENTIFYING NO	SPECIFICATION	MATERIALS OR NOTES
LIST OF MATERIALS OR PARTS LIST					
APPROVED		DATE			
DRAWN <i>W. Hueston</i>		8-16-78			
CHECKED <i>P. L. King</i>		9-16-78			
DRAWN <i>P. L. King</i>		8-8-78			
UNLESS OTHERWISE SPECIFIED DIMENSIONS SHALL FALL WITHIN THE TOLERANCE LIMITS LISTED BELOW					
BASIC DIM	1.25 - 1.75	FRACTIONAL DIM	1.00 - 1.50	DECIMAL DIM	1.50 - 1.75
LENGTH	± .02	ANGLE	± .10	LENGTH	± .02
ODI	± .02	ANGLE	± .10	LENGTH	± .02
ODI	± .02	ANGLE	± .10	LENGTH	± .02
ODI	± .02	ANGLE	± .10	LENGTH	± .02
SCALE: 1/4" = 1'-0"					
PART OR IDENTIFYING NO: 325 056					
SHEET OF					

**TetraTek**

Fig. 9 Hole level from extensometer drift.

ZONE	LTR	DESCRIPTION	DATE	APPROVED
------	-----	-------------	------	----------

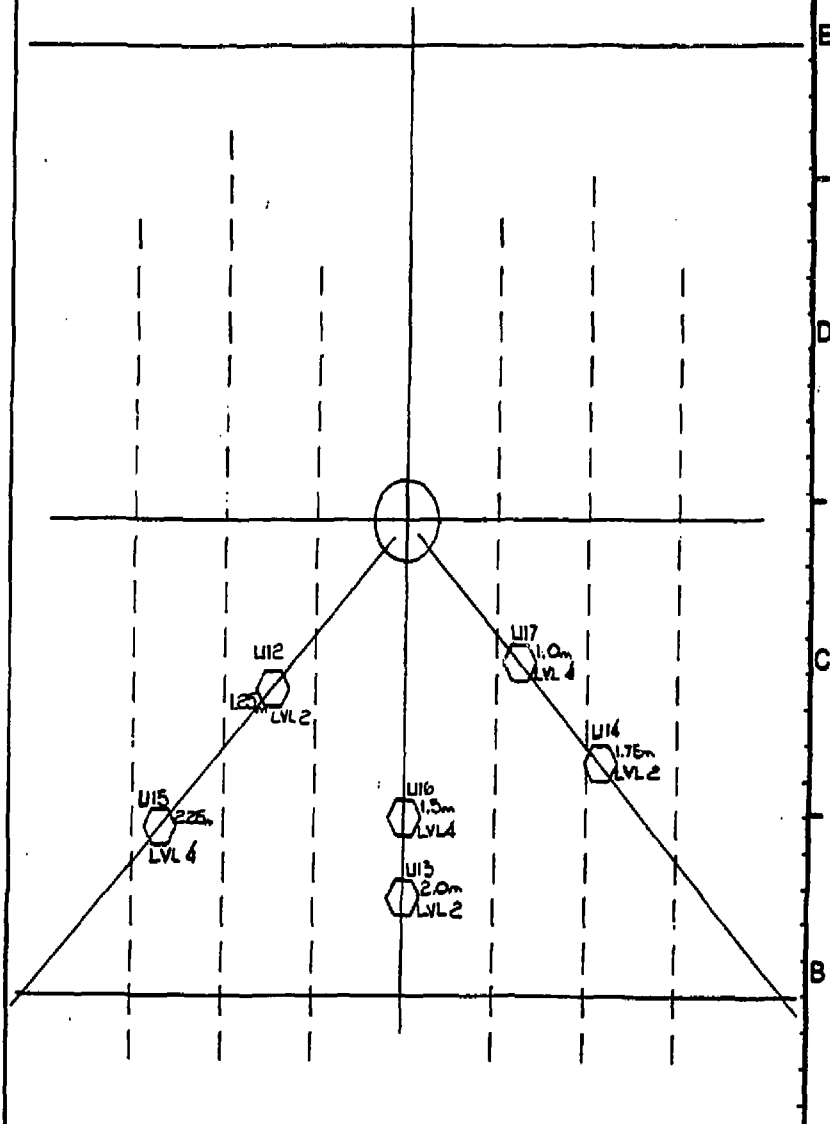

ITEM	QTY	NOMENCLATURE OR DESCRIPTION	PART OR IDENTIFYING NO	SPECIFICATION	MATERIALS OR NOTES
LIST OF MATERIALS OR PARTS LIST					
APPROVED			DATE		
DRAWN <i>W. Husted</i>			DATE <i>8-16-78</i>		
CHECKED <i>R. King</i>			DATE <i>9-16-78</i>		
DATE <i>8-8-78</i>			<p>Fig. 10 Location of USB gages installed for extensometer drift.</p>		
UNLESS OTHERWISE SPECIFIED DIMENSIONS SHALL FALL WITHIN THE TOLERANCE LIMITS LISTED BELOW					
BASIC DIM	FRACTION	TOLERANCE	BASIC DIM	DECIMAL	TOLERANCE
UNDER 1"	± .005	± .005	UNDER 1" mm	± .02	± .02
1" TO 2"	± .005	± .005	1" TO 2" mm	± .02	± .02
OVER 2"	± .005	± .005	OVER 2" mm	± .02	± .02
ANGLES 90°			SCALE <i>2x</i>	RA	SHEET <i>1</i> OF <i>1</i>

ZONE	LTR	DESCRIPTION	DATE	APPROVED
------	-----	-------------	------	----------

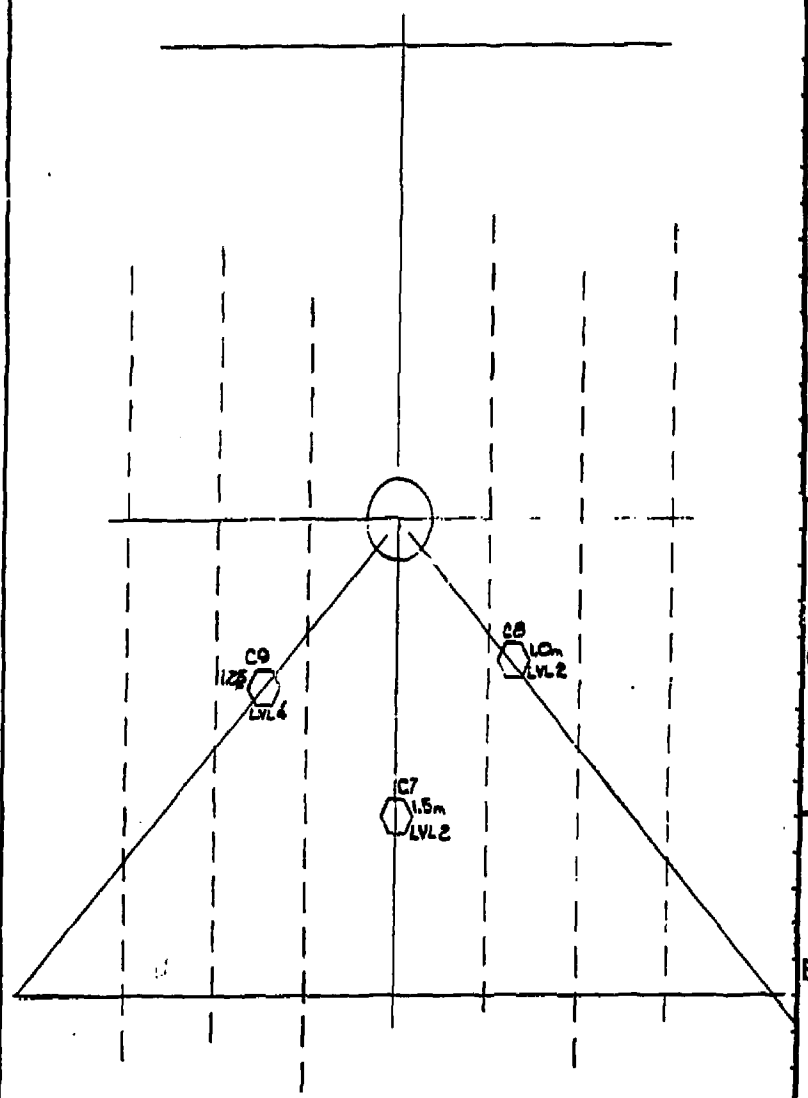

ITEM	QTY	NUMERICAL OR DESCRIPTION	PART OR IDENTIFYING NO	SPECIFICATION	MATERIALS OR NOTES																																																												
LIST OF MATERIALS OR PARTS LIST																																																																	
APPROVED			DATE	<b>TerraTek</b> Fig. 11 Location of IRAD gages installed from extensometer drift.																																																													
DRAWN BY			DATE																																																														
CHECKED BY			DATE																																																														
DESIGNED BY			DATE																																																														
<table border="1" style="width: 100%; border-collapse: collapse;"> <tr> <td style="width: 20%;">UNION 6"</td> <td style="width: 10%;">1.00</td> <td style="width: 10%;">2.00</td> <td style="width: 10%;">2.00</td> <td style="width: 10%;">2.00</td> <td style="width: 10%;">2.00</td> <td style="width: 10%;">2.00</td> <td style="width: 10%;">2.00</td> <td style="width: 10%;">2.00</td> <td style="width: 10%;">2.00</td> <td style="width: 10%;">2.00</td> <td style="width: 10%;">2.00</td> <td style="width: 10%;">2.00</td> <td style="width: 10%;">2.00</td> <td style="width: 10%;">2.00</td> <td style="width: 10%;">2.00</td> <td style="width: 10%;">2.00</td> <td style="width: 10%;">2.00</td> <td style="width: 10%;">2.00</td> <td style="width: 10%;">2.00</td> </tr> <tr> <td>6" TO 34"</td> <td>1.00</td> <td>1.00</td> <td>1.00</td> <td>1.00</td> <td>1.00</td> <td>1.00</td> <td>1.00</td> <td>1.00</td> <td>1.00</td> <td>1.00</td> <td>1.00</td> <td>1.00</td> <td>1.00</td> <td>1.00</td> <td>1.00</td> <td>1.00</td> <td>1.00</td> <td>1.00</td> <td>1.00</td> </tr> <tr> <td>OVER 34"</td> <td>1.00</td> <td>1.00</td> <td>1.00</td> <td>1.00</td> <td>1.00</td> <td>1.00</td> <td>1.00</td> <td>1.00</td> <td>1.00</td> <td>1.00</td> <td>1.00</td> <td>1.00</td> <td>1.00</td> <td>1.00</td> <td>1.00</td> <td>1.00</td> <td>1.00</td> <td>1.00</td> <td>1.00</td> </tr> </table>						UNION 6"	1.00	2.00	2.00	2.00	2.00	2.00	2.00	2.00	2.00	2.00	2.00	2.00	2.00	2.00	2.00	2.00	2.00	2.00	2.00	6" TO 34"	1.00	1.00	1.00	1.00	1.00	1.00	1.00	1.00	1.00	1.00	1.00	1.00	1.00	1.00	1.00	1.00	1.00	1.00	1.00	OVER 34"	1.00	1.00	1.00	1.00	1.00	1.00	1.00	1.00	1.00	1.00	1.00	1.00	1.00	1.00	1.00	1.00	1.00	1.00	1.00
UNION 6"	1.00	2.00	2.00	2.00	2.00	2.00	2.00	2.00	2.00	2.00	2.00	2.00	2.00	2.00	2.00	2.00	2.00	2.00	2.00																																														
6" TO 34"	1.00	1.00	1.00	1.00	1.00	1.00	1.00	1.00	1.00	1.00	1.00	1.00	1.00	1.00	1.00	1.00	1.00	1.00	1.00																																														
OVER 34"	1.00	1.00	1.00	1.00	1.00	1.00	1.00	1.00	1.00	1.00	1.00	1.00	1.00	1.00	1.00	1.00	1.00	1.00	1.00																																														
SCALE OF DRAWING			SHEET NO																																																														





ZONE	LTR	DESCRIPTION	DATE	APPROVED
------	-----	-------------	------	----------

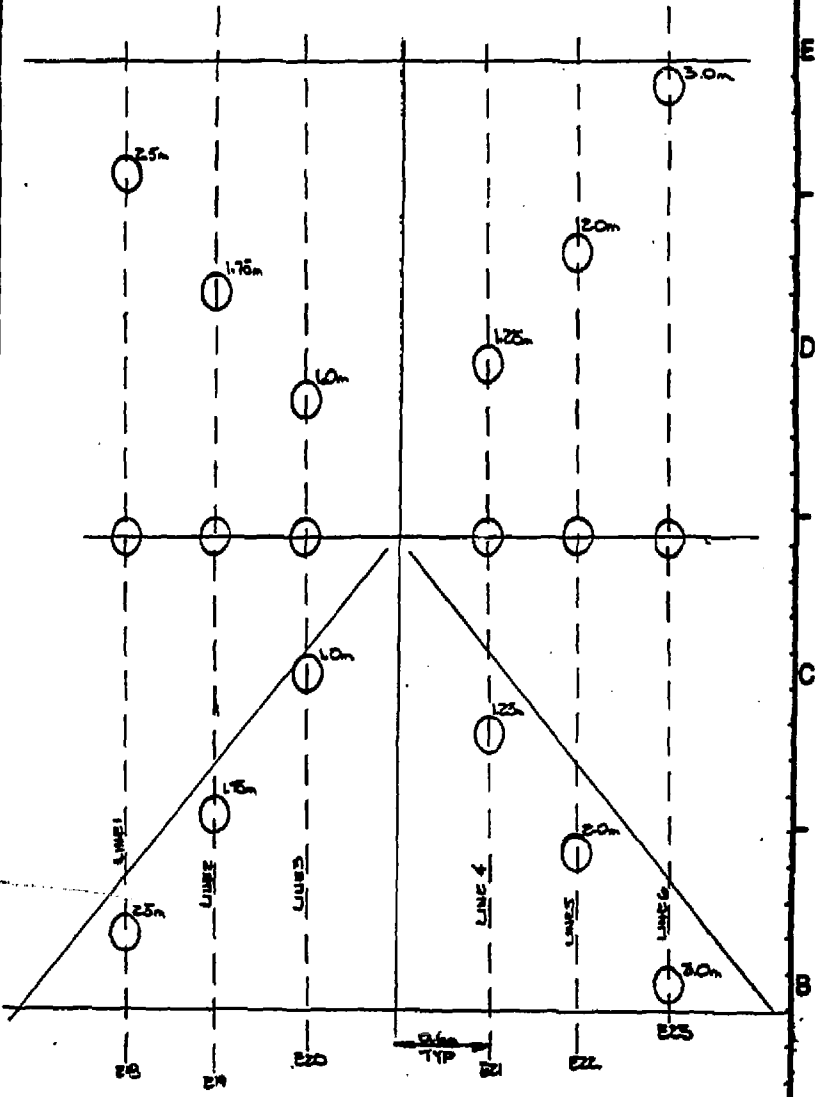

ITEM	QTY	NOMENCLATURE OR DESCRIPTION	PART OR IDENTIFYING NO	SPECIFICATION	MATERIALS OR NOTES																												
LIST OF MATERIALS OR PARTS LIST																																	
APPROVED	DATE																																
DESIGNED	W. Hueston		0-11-72	<b>Tonalok</b>																													
CHECKED	P. G. ...		8-11-72																														
DRAWN	E. ...		8-11-72	Fig. 13 Location of horizontal anchors, Level 3. <div style="float: right; border: 1px solid black; padding: 5px;"> <b>A</b> 325080           </div>																													
CALCULATED BY ...																																	
CHECKED BY ...																																	
APPROVED BY ...																																	
DATE ...																																	
<table border="1" style="width: 100%;"> <tr> <td>LINE NO.</td> <td>QTY</td> <td>DESCRIPTION</td> <td>UNIT</td> </tr> <tr> <td>1</td> <td>...</td> <td>...</td> <td>...</td> </tr> <tr> <td>2</td> <td>...</td> <td>...</td> <td>...</td> </tr> <tr> <td>3</td> <td>...</td> <td>...</td> <td>...</td> </tr> <tr> <td>4</td> <td>...</td> <td>...</td> <td>...</td> </tr> <tr> <td>5</td> <td>...</td> <td>...</td> <td>...</td> </tr> <tr> <td>6</td> <td>...</td> <td>...</td> <td>...</td> </tr> </table>						LINE NO.	QTY	DESCRIPTION	UNIT	1	...	...	...	2	...	...	...	3	...	...	...	4	...	...	...	5	...	...	...	6	...	...	...
LINE NO.	QTY	DESCRIPTION	UNIT																														
1	...	...	...																														
2	...	...	...																														
3	...	...	...																														
4	...	...	...																														
5	...	...	...																														
6	...	...	...																														
SCALE: 1/4" = 1'-0"																																	

TABLE 1.  
SUMMARY OF HOLE AND INSTRUMENTATION  
REQUIREMENTS PER EXPERIMENT  
IN CLIMAX STOCK GRANODIRITE

HOLES	QUANTITY	INSTRUMENTATION CHANNELS				
		TC	USBM	IRAD	DCDT	OTHER
H (V)	1	6				8
E (V)	11	66			44	2
M (V)	10	7				3
U/C (V)	12	17	33	12		4
T (V)	6	48				
E (H)	12	60			36	2
U/C (H)	6	9	18	6		4
M (H)	11	7				3
TOTAL	68	208	51	18	80	26

GRAND TOTAL = 383

(V) - VERTICAL HOLE  
(H) - HORIZONTAL HOLE

### Testing Procedure

It is recommended that the full scale heater sites be used for several tests at increasing power levels. The question of "how good is granite" needs to be evaluated. Two possible testing sequences are shown in Figures 14 and 15. For example, the heater would be turned on a 1 kw for a period of 2 to 3 months and then turned off for a similar period or until the initial ambient temperature has been reached. During such a heating period, the rock should reach approximately 80-90% of the maximum temperature it would achieve over an infinitely long heating time. Data from the instruments would be collected both during the heating and cooling periods. The heater would then be pulled out of the hole and inspections made of both it and the hole. Geophysical, permeability and other appropriate measurements would be made to evaluate any changes in the site as a result of the heating. Instruments could be repaired and recalibrated if necessary. The heater would then be turned on at a 2 kw power level and the process repeated. At the higher power levels, it is felt that the site will degrade and some of the closer instrumentation may be lost due to the high temperatures. These close-in instruments are needed to collect data during earlier times and lower power levels. The site essentially has to be instrumented to provide data for 5 different experiments (1,2,4,8 and 16 kw power levels), therefore, some additional instrumentation is needed over what would be required to do the five experiments singly and the site/process definition obtained would be much better.

# HEATER TESTS POWER LEVEL VS TIME

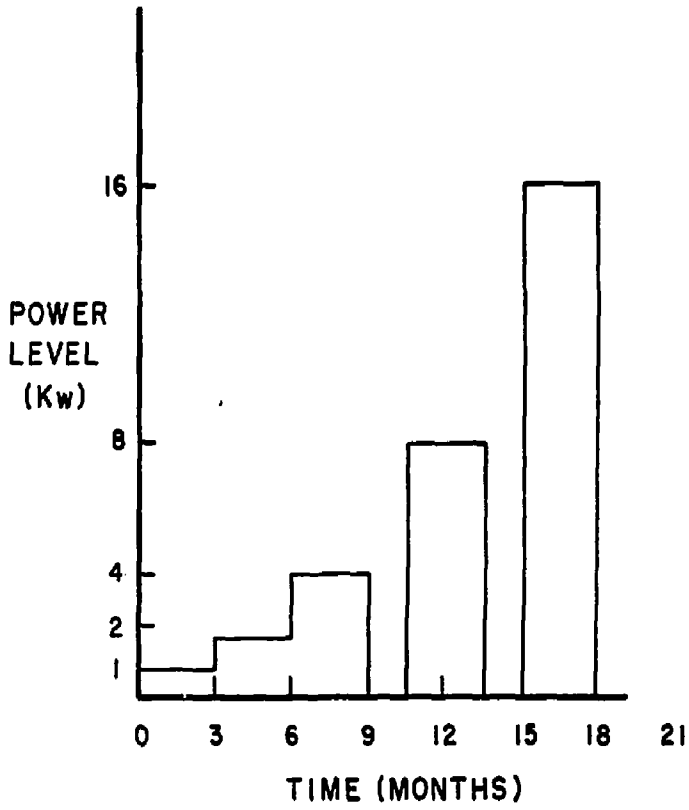

Figure 14.

# HEATER TESTS POWER LEVEL VS TIME

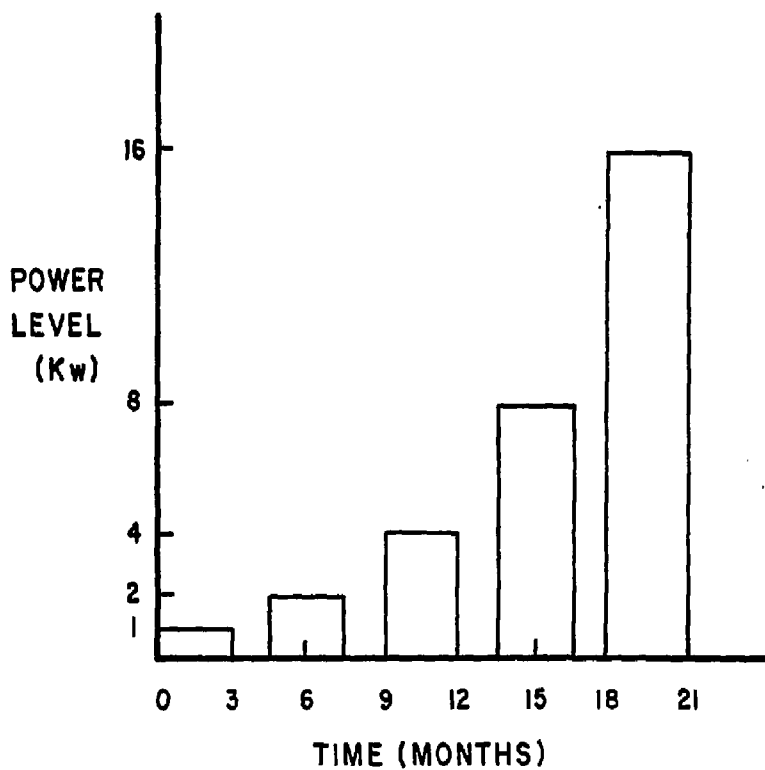

Figure 15.

## SPENT FUEL FACILITY

### Introduction

The proposed spent fuel site (see figure 16) will contain 11 spent fuel canisters and 6 electric heaters in one drift 15 ft wide, 22 ft high, and approximately 200 ft long. It will be serviced by a train running on standard gauge tracks (4 1/2 ft between rails).

each of the holes to provide a radiation shield (figure 17). This will be low level waste with each canister having a heat output of about 1 kw. Two additional drifts will run parallel to the canister drift. These will contain additional electric heaters to help simulate a large repository of canisters.

### Excavation Schedule

As presently planned, the North and South heater drifts are to be driven first, followed by excavation of the canister storage drift.

Some important dates for the project are the following:

- November 1, 1978    Begin excavation of heater drifts
- December 15, 1978    Complete excavation of heater drifts
- December 15, 1978    Begin excavation of canister drift
- February 1, 1979    Complete excavation of canister drift
- February, 1979    Canister holes drilled
- March, 1979    Liners emplaced
- April, 1979    Floor poured
- May-August, 1979    Installing rock mechanics instrumentation in canister drift
- October, 1979    Begin emplacing spent fuel.

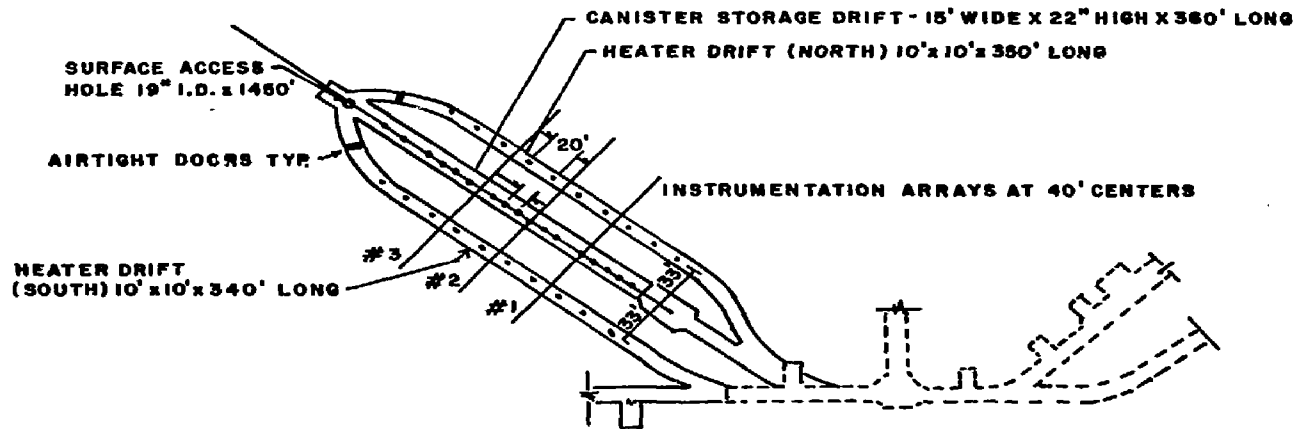

Figure 16. Underground Layout of Spent Fuel Test Showing Recommended Rock Mass Response Instrumentation Locations.



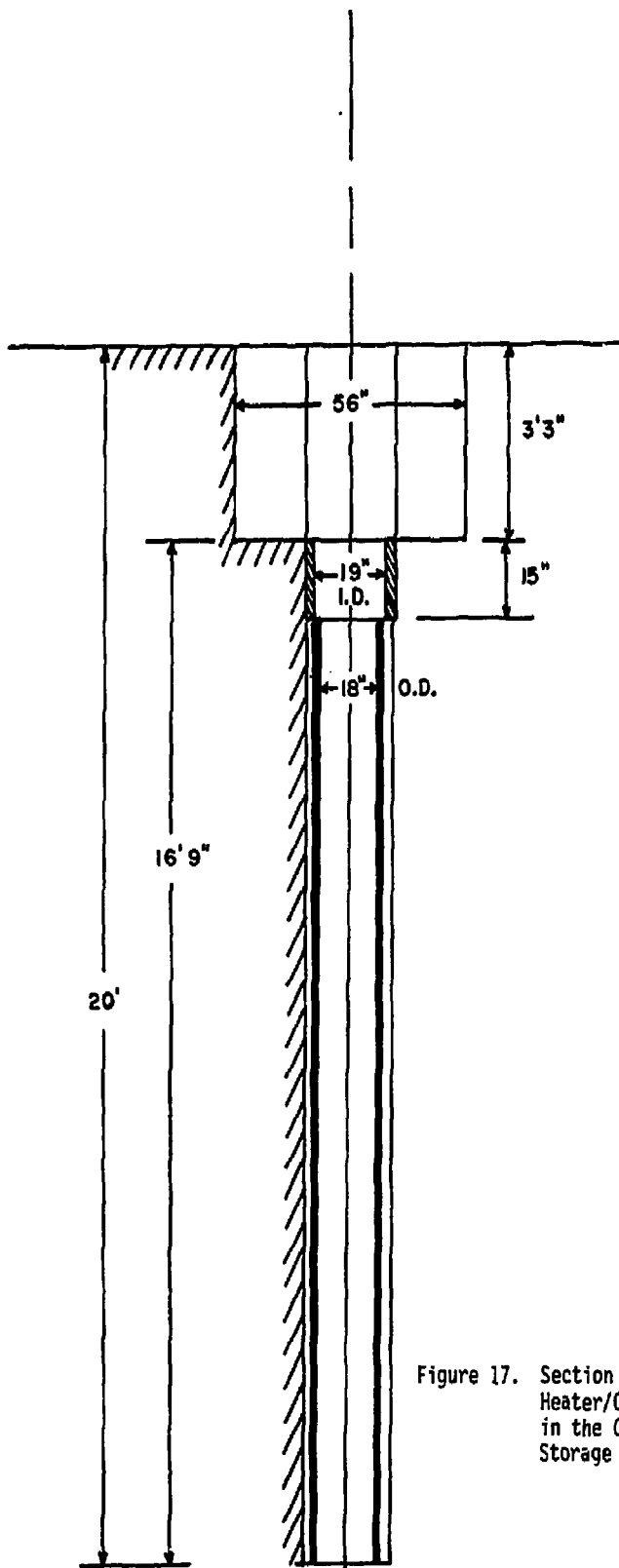

Figure 17. Section View of the  
 Heater/Canister Holes  
 in the Canister  
 Storage Drift.

For the rock mass characterization program, instrumentation should be installed during the time period November-December, 1978. The instruments must be ordered immediately to meet this schedule. The spent fuel drift instrumentation should be installed during May-August, 1979. It should be ordered by January 1, 1979.

## Rock Mass Instrumentation Program

Purpose of the Measurements. Measured rock properties are very sensitive to the volume of rock being tested and the loading conditions. To evaluate the rock mass properties, which are appropriate for repository design, a rock block having dimensions several times the planned opening size should be studied under actual loads. The easiest way of doing this is to monitor the deformations which occur when the openings are created. The measurement program must be very carefully coordinated with finite element modeling of the geometries and loading conditions. If the *in situ* stress conditions are known, then a modulus is assumed for the model and the predicted displacements compared to those actually measured. The modulus value is then varied until agreement between displacements is obtained. If the *in situ* stress condition is unknown, but the deformation modulus known, then the loads applied to the finite element model are varied until the measured and predicted displacements agree. In general, the first case is the most common. The instrumentation program described is aimed at obtaining deformation moduli for the rock mass containing the spent fuel drifts.

Excavation Procedures. The excavation of the top heading and bench should be done carefully. It is recommended that either pre-split or smooth wall blasting techniques be used at the periphery of the openings. This will minimize (1) damage to rock and (2) possible damage to the measurement instruments. For extensometers installed from the North and South drifts, the closest approach to the planned canister drift is about 3 ft. This means that both the instrument borehole orientation and the room geometry will have to be very carefully controlled.

The convergence points are installed in the wall of the top heading drift. These must be placed in competent, undisturbed rock to give meaningful results.

They must also be protected from effects of blasting the bench.

Types of Measurements. It is felt that the most useful and straightforward measurements which can be made are deformations. These can be two types:

1. convergence of roof-floor and wall-wall as monitored from surface set points, and
2. internal rock mass deformation changes as monitored by multiple point extensometers.

Both techniques are recommended for use here. Some instrumentation layout possibilities are described later.

The extensometers should be of the rod type with anchors grouted in place. Both electrical and mechanical readout should be possible. Long-term monitoring is necessary as monitoring will take place during both the construction and operational phases. The time/temperature degradation of the canister storage drift should be detectable using these devices.

The convergence points in the canister drift top heading will provide deformation changes due to the benching operation. They can be monitored up to the time of waste emplacement. After that time, they will probably be inaccessible since the readings are generally taken manually. Convergence points installed in the North and South drifts can be monitored both during mining of the canister drift and during the operational period. These will probably show little change due to canister drift mining, but could reveal time and temperature effects on heater drift stability. In fact, it may be desirable to use these drifts as test sites for the roof stability tests described in another section of this report.

Location of Instrumentation. There are a number of different ways in which the rock mass behavior could be monitored given the geometry and mining sequence. Four options are shown in Figures 18-21. The exact positions of the

anchors will depend upon the results of finite element model simulation.

Option A. At each measurement section, Figure 18, three 3-point extensometers would be installed from the South drift toward the canister drift prior to excavation of either the top heading or the bench. All instruments would be monitored as a function of excavation process. The convergence points would be installed and read after excavation of the top heading and prior to benching. It is preferable, although not mandatory, that the extensometer holes be diamond drilled. They could all be drilled from one set up (center of South drift) using a column and bar mounted diamond drill. The drilling of the heater holes in the floor or other work could proceed in the North drift while instrumentation installation is underway in the South. Roof-floor and wall-wall convergence instrumentation could be installed in both the North and South drifts, however, it is doubtful that they will show much involvement with excavation of the canister drift. This would have to be evaluated by finite element modelings prior to excavation. It is recommended that this instrumentation plan be repeated on 3 sections at 40 ft intervals. Convergence points should be installed more often.

Option A'. This is the same as option A with the exception that four 4-point extensometers would be installed at each section (figure 19). The purpose of the fourth point on the extensometer would be to monitor the stability of the heater drift as a function of time and the imposed thermal loading. These drifts could also be used as the sites for the roof stability tests described later.

Option B. This is similar to option A except that at each section on extensometer instrumentation would be installed from both the South and North drifts (figure 20). The advantage over option A is that it would reveal the symmetry (or antisymmetry) of the rock mass deformation. The disadvantages are that it would (1) require twice the instrumentation as option A; (2) involve

operating in and instrumenting two drifts, and (3) possibly delay other construction activities which might be carried out simultaneously in the other drift.

Option C. In this option, all instrumentation is installed in the top heading, after drifting, but prior to benching (figure 21). The changes resulting from the benching operation would be observed. The advantages are that (1) the drill holes are shorter, (2) their position can be easily controlled, and (3) the anchor points can be placed closer to the wall of the excavation. The disadvantages are (1) instrumentation installation will interfere with the construction cycle, (2) high probability of some instrumentation being destroyed due to construction, (3) no possibility to measure deformations due to driving top heading, and (4) problems of repairing the readout heads after waste emplacement.

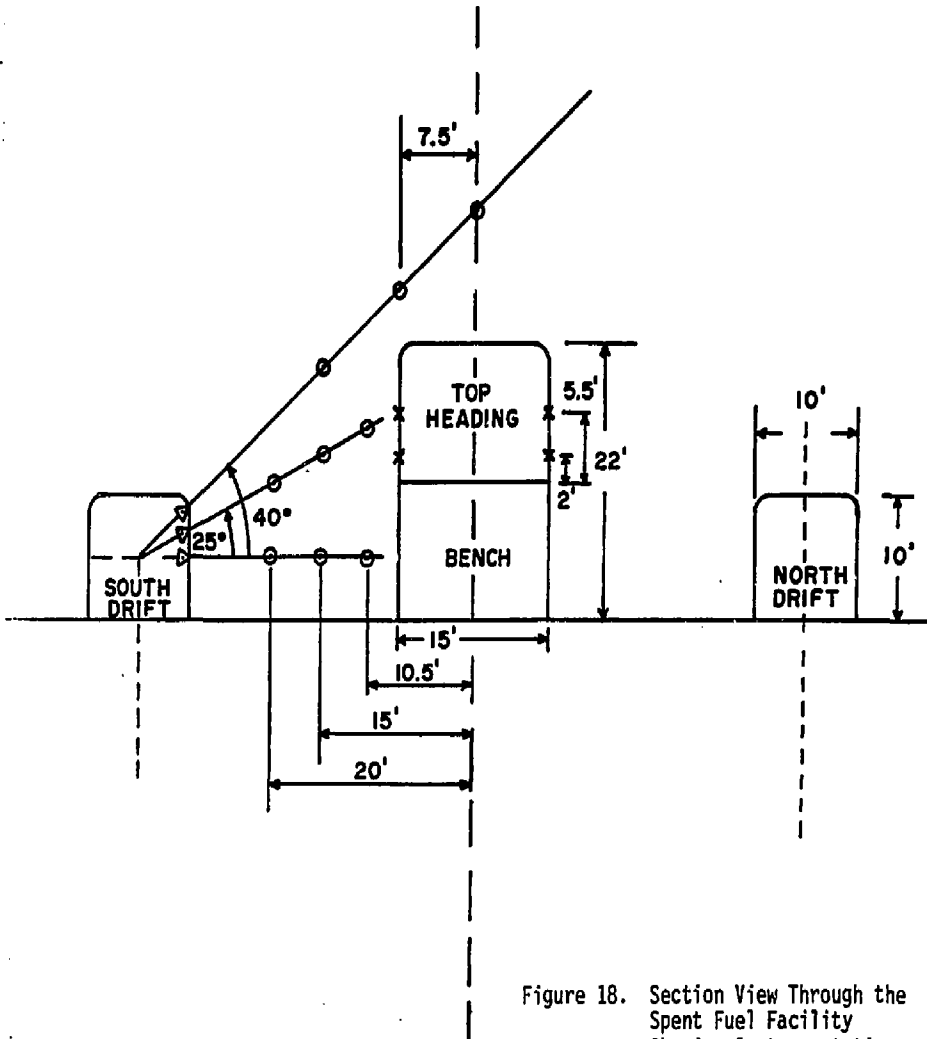

Figure 18. Section View Through the Spent Fuel Facility Showing Instrumentation Location - Option A.

**KEY:**

- ▽ EXTENSOMETER HEADS
- EXTENSOMETER ANCHORS
- X CONVERGENCE POINTS

NOTE : CONVERGENCE POINTS NOT SHOWN

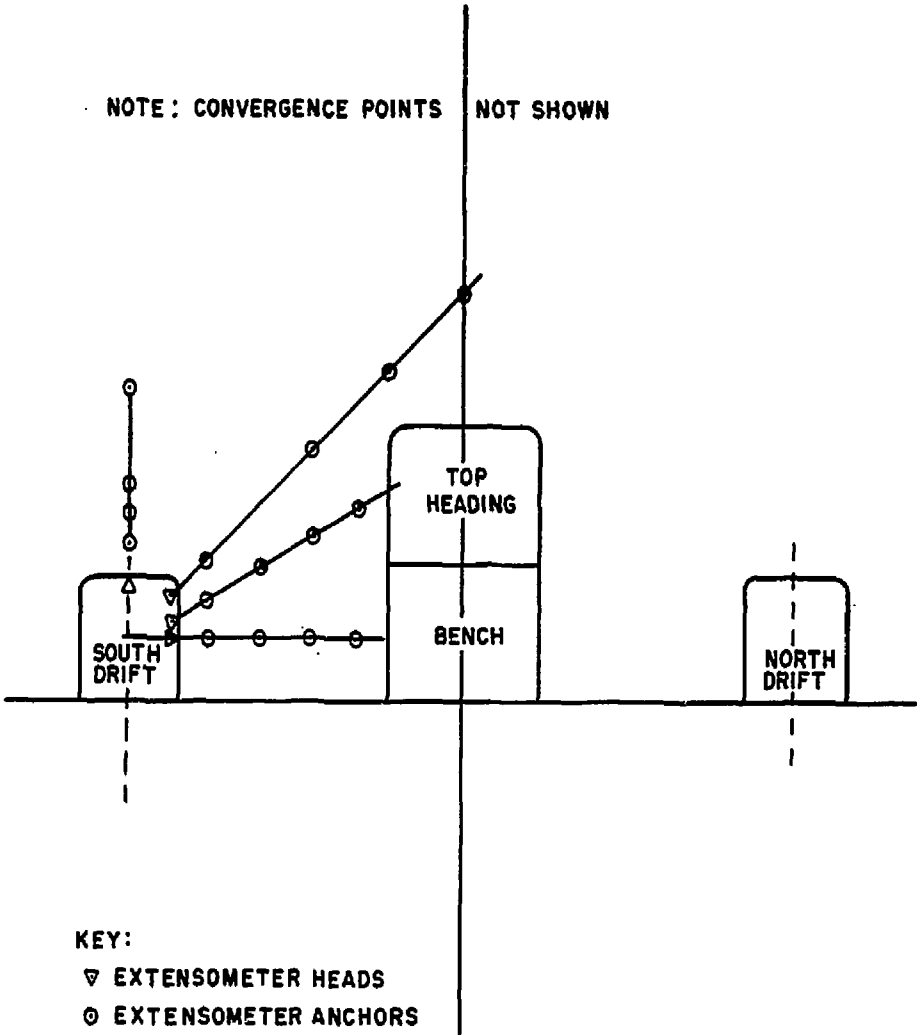

Figure 19. Section View Through the Spent Fuel Facility Showing Instrumentation Location - Option A'.



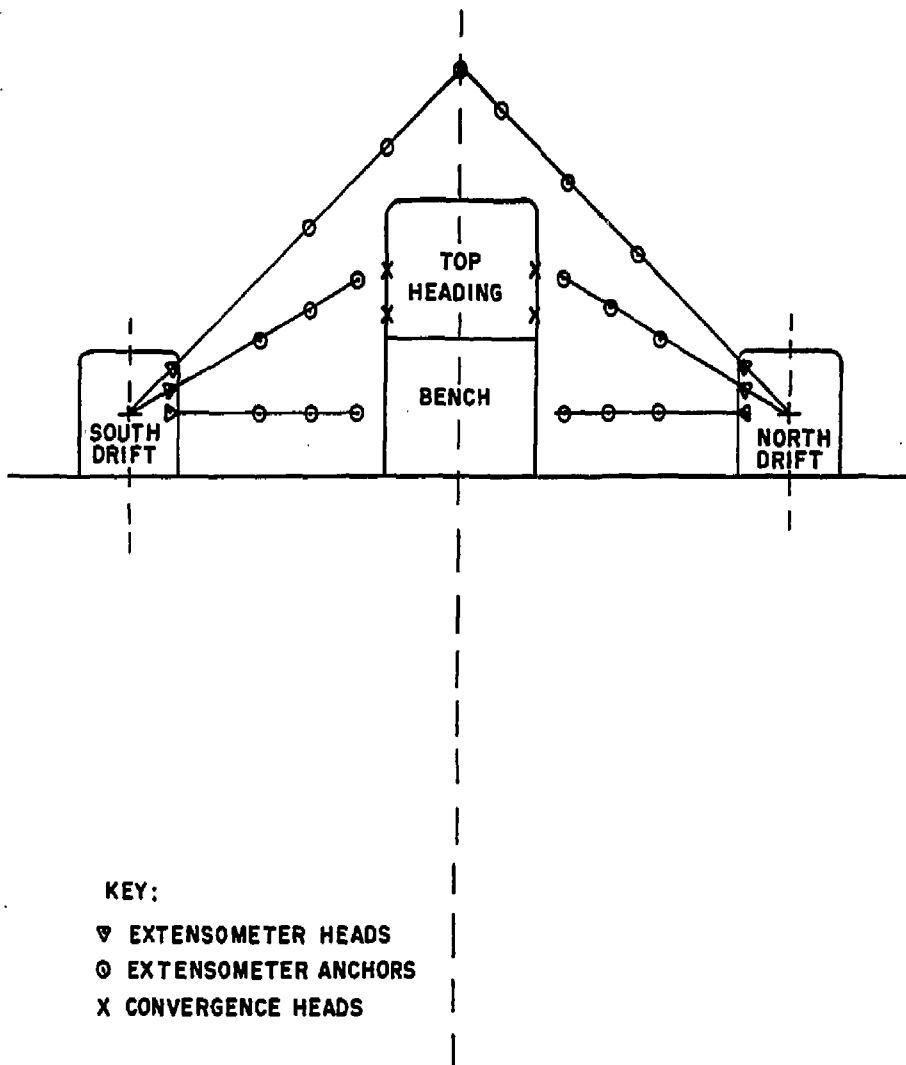
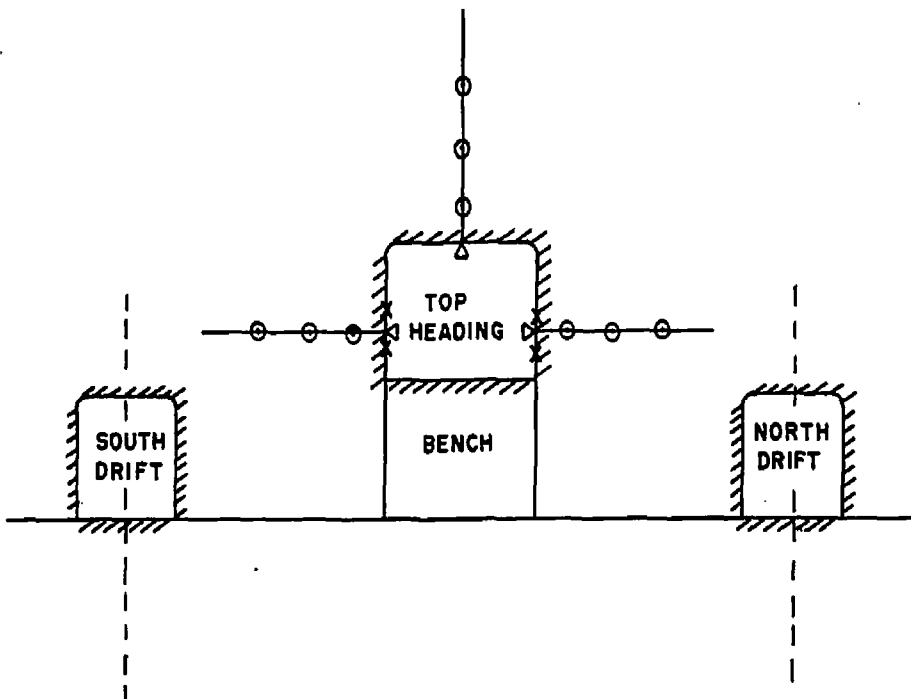

Figure 20. Section View Through the Spent Fuel Facility Showing Instrumentation Location - Option B.



**KEY:**

- ▼ EXTENSOMETER HEADS
- ⊙ EXTENSOMETER ANCHORS
- X CONVERGENCE POINTS

Figure 21. Section View Through the Spent Fuel Facility Showing Instrumentation Location - Option C.

## Spent Fuel Drift Measurement Program

Purpose of the Measurements. The waste handling requirements and other actual operating constraints greatly restrict the types of measurements that can be made during operation (figure 22). The large number of holes, however, provide the opportunity to evaluate the average properties and variations within a large volume of rock. Furthermore, since the thickness to lateral dimension ratio of the heated zone is somewhat similar to that expected for an actual repository, the resulting displacement and thermal fields should be representative. Therefore, a measurement program to monitor the operating spent fuel facility is also recommended.

Instrumentation Layout. The recommended basic site evaluation and monitoring will be done for each canister from three vertical holes placed in a triangular pattern (see figure 23 through 26). The radial distance of each hole from the canister hole is different to allow a three dimensional site evaluation to be made. The holes could be percussion drilled 2.2 in in diameter so that ultrasonic (crosshole and uphole) surveys can be made prior to canister emplacement. Such surveys would form one means of accepting or rejecting a hole for canister storage. The variability throughout the site could thereby be quantified, and compared to average site properties. This would provide a measure for recommending the degree of further site evaluation required. Permeability tests could also be done in these holes. If this is the case, then the holes should be diamond drilled.

Thermocouples could be installed in these holes prior to canister loading for monitoring the thermal fields. Some holes may be left open for other types of monitor tools (that can be remotely operated).

The only other type of instrumentation recommended for the canister drift are extensometers (figure 27). These would monitor the deformation of the floor and the development of tension zones at the ends of the heated region. These measurements when compared to the predicted elastic models would suggest the opening of fractures and the potential for high permeability zones.

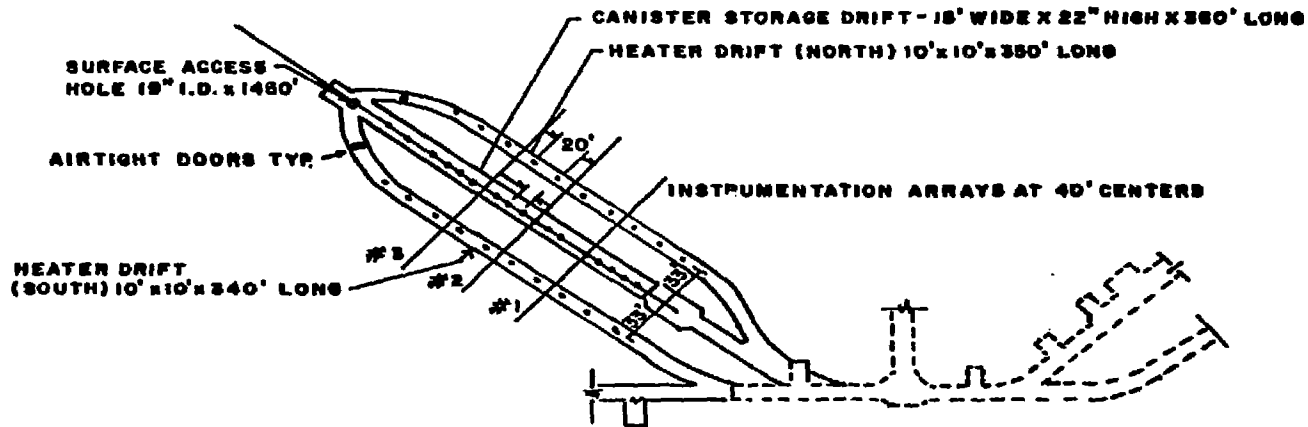

Figure 22. Underground Layout of Spent Fuel Test Showing Recommended Rock Mass Response Instrumentation Locations.

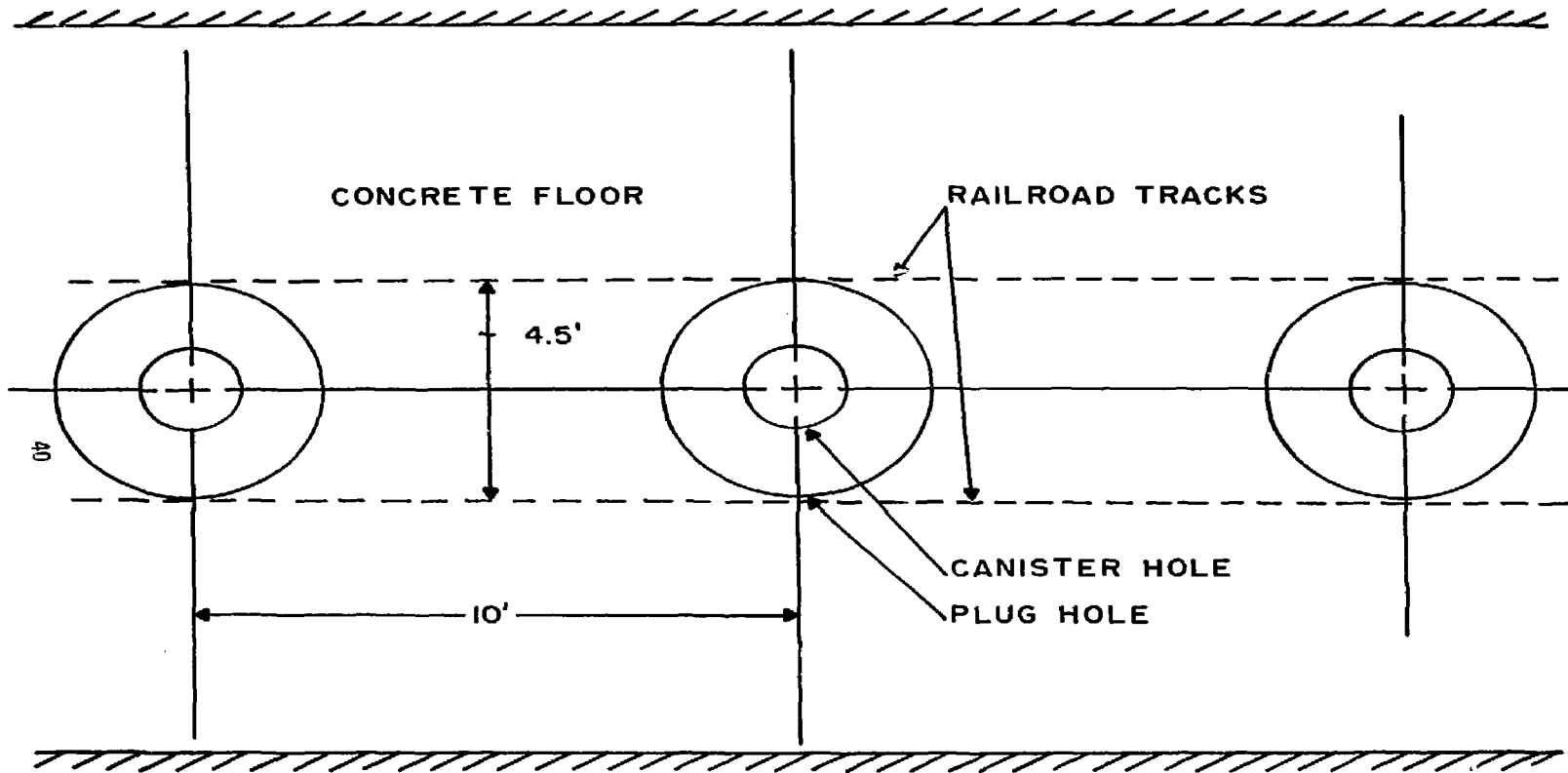
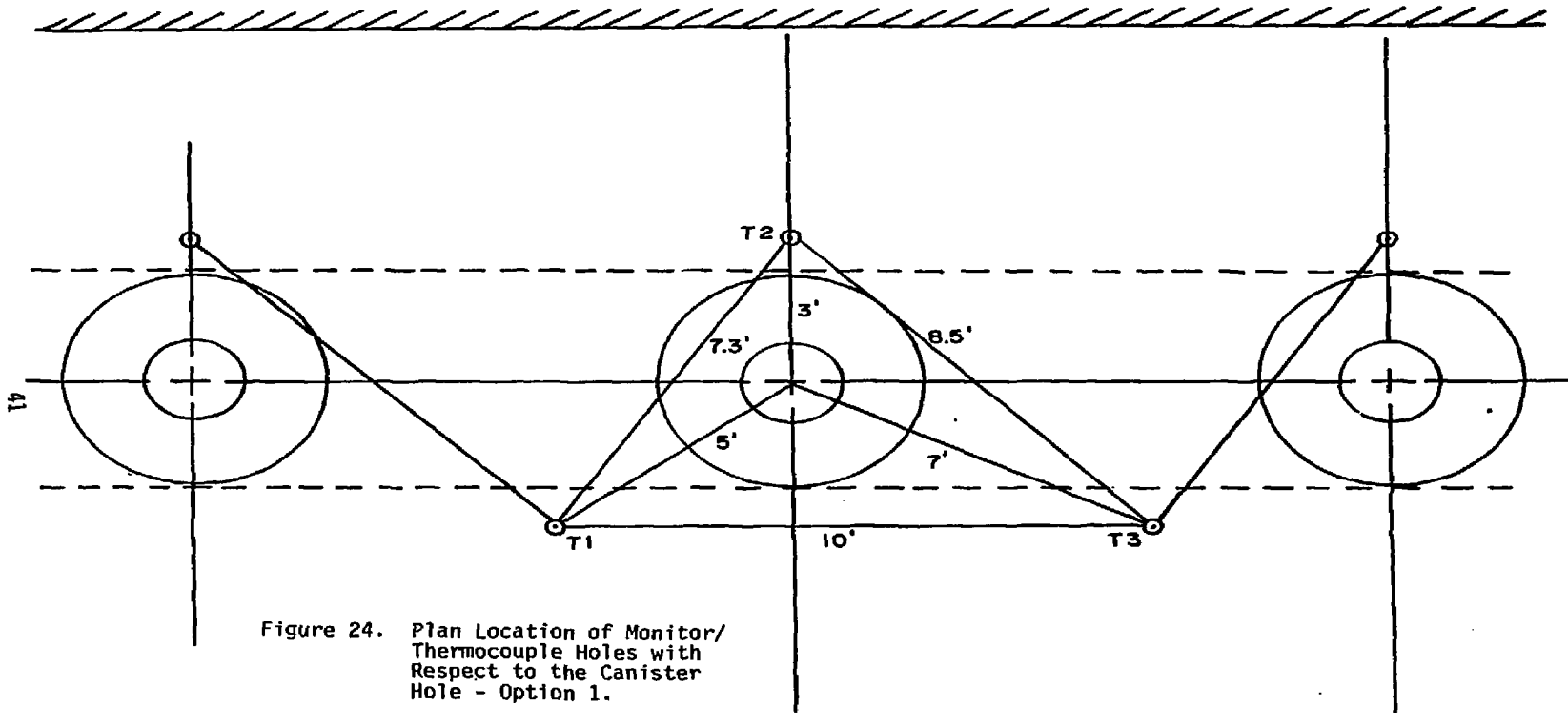

Figure 23. Representation of the Canister Holes in the Canister Drift Showing Hole Geometry and Rail Location.



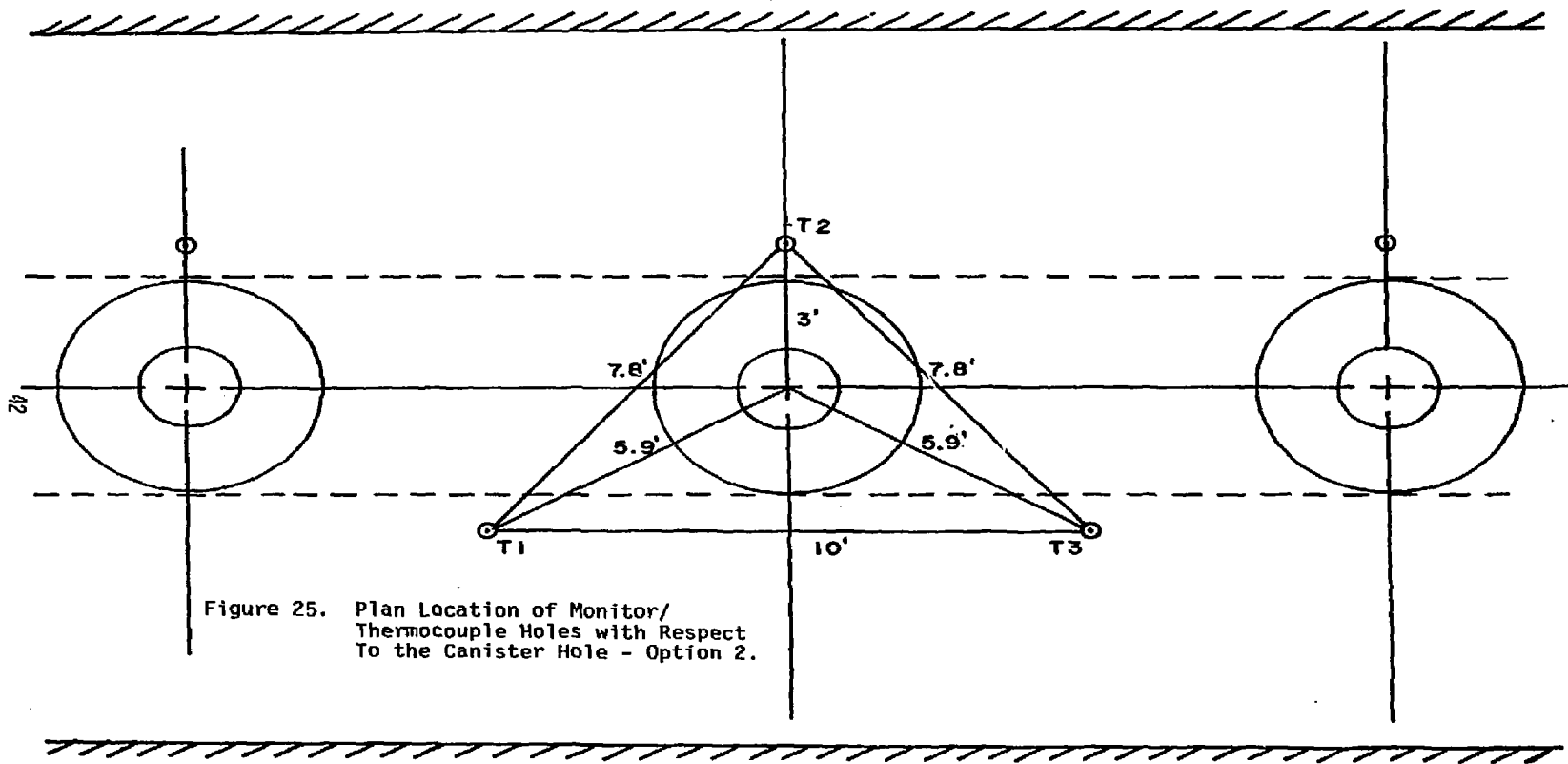

Figure 25. Plan Location of Monitor/  
Thermocouple Holes with Respect  
To the Canister Hole - Option 2.



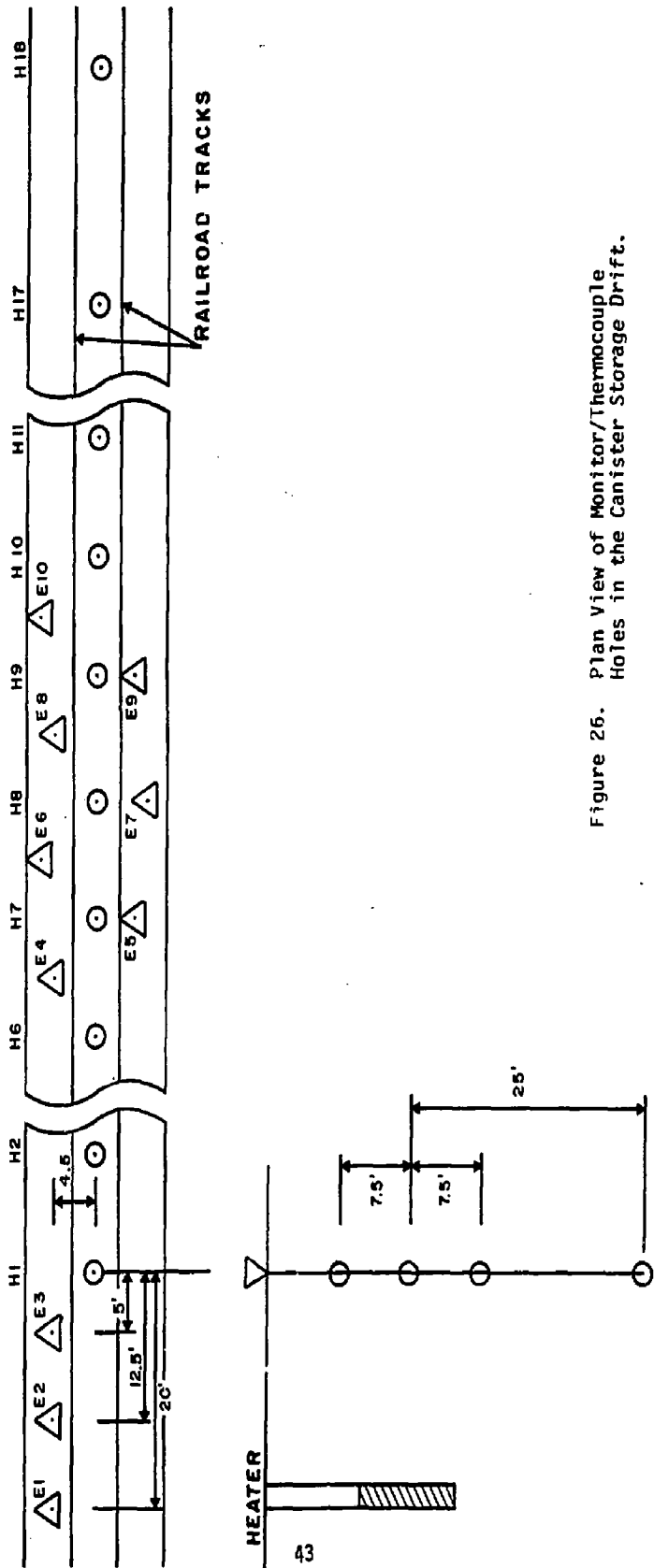
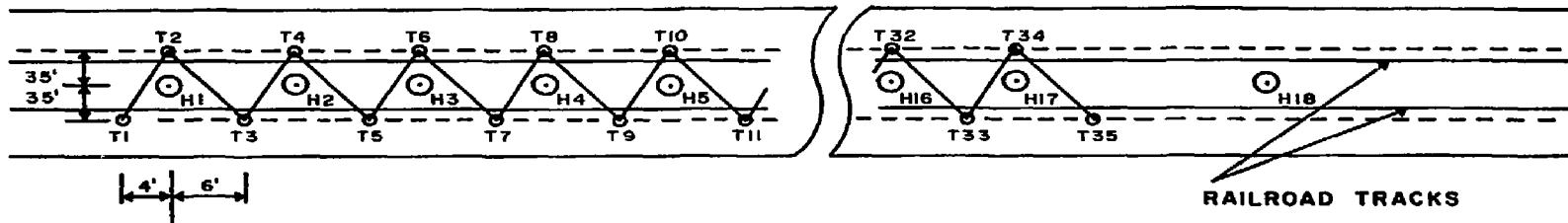

Figure 26. Plan View of Monitor/Thermocouple Holes in the Canister Storage Drift.



44

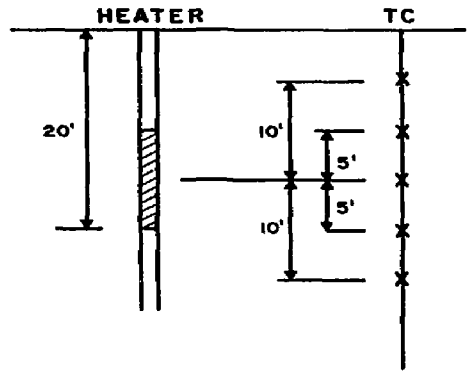

Figure 27. Location of the Extensometer Holes in the Canister Storage Drift.

## HEATED ROOM EVALUATION

### Introduction

The need for retrievability requires that the openings remain stable for long periods. Hence, one must consider ways for evaluating the effects of time and thermal loadings on the stability of the openings.

### Room Stability Evaluation

It would appear that the potential for thermally induced roof instability is considered greater and of much greater consequence than thermally induced pillar problems. Therefore, one should strongly consider heating a specially excavated sealed room and monitoring the effect of time and temperature on roof and wall stability. The test would be done in phases; for example:

Phase 1. heat to  $\Delta T = 20^{\circ}\text{C}$  and hold for 6 months ( $\Delta T$  is over the mine ambient temperature),

Phase 2. increase to  $\Delta T = 40^{\circ}\text{C}$  and hold for 6 months, and

Phase 3. increase to  $\Delta T = 60^{\circ}\text{C}$  and hold for 6 months.

The humidity should be kept at about 100% at each temperature. This temperature range probably brackets the range that might be reasonably expected during the emplacement and retrievability phases. Calculations could be conducted to better define these temperatures. Both separation of roof layers and roof-floor convergence would be monitored. Instrumentation does exist which could be adapted for this purpose. One could consider doing this test in the South heater drift and make use of the rock mass characterization instrumentation.

## Analysis of the Proposed Pillar Experiment

It has been proposed by others to perform some heated pillar tests as part of the L<sup>3</sup> experiment in NTS granite. A plan view is shown below:

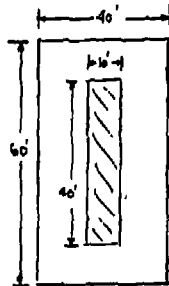

Assuming the depth is 1000 feet and the density of the overburden is such as to provide 1 psi/ft of depth, then the initial vertical stress is  $\sigma_v = 1000$  psi. The loading of the pillar can be achieved by (a) mining out of the rock surrounding the pillar and/or (b) loading by thermal expansion.

The first part can be expressed as:

$$\sigma_{p1} = \frac{\sigma_v}{1-R} \quad (1)$$

where

$R$  = extraction ratio

$\sigma_{p1}$  = average pillar stress (extraction) psi

The second part is:

$$\sigma_{p2} = E\epsilon_T \quad (2)$$

where

$$\epsilon_T = \alpha\Delta T \quad (3)$$

$\alpha$  = linear coefficient of expansion (Strain/<sup>o</sup>C)

$\Delta T$  = average change in pillar temperature (<sup>o</sup>C)

$\epsilon_T$  = average thermally induced strain (strain)

$E$  = deformation modulus of pillar (psi)

to achieve pillar failure:

$$C_p = \sigma_{p_1} + \sigma_{p_2} \quad (4)$$

where

$C_p$  = average compressure strength of the pillar (psi)

For the proposed geometry shown in the figure, the extraction ratio is:

$$R = \frac{(40)(60) - 40(10)}{40(60)} = \frac{20}{24} \approx 0.8 \quad (5)$$

thus

$$\sigma_{p_1} = \frac{\sigma_v}{1-0.8} \approx 5000 \text{ psi}$$

Assuming that the compressure strength of the pillar is 20,000 psi, then the thermal portion of the loading would have to account for 15,000 psi:

$$\sigma_{p_1} = E \alpha \Delta T \quad (6)$$

Substitutive representative values for granite:

$$\alpha = 6 \times 10^{-6} / ^\circ\text{F}$$

$$E = 4 \times 10^6 \text{ psi}$$

and solving for the required  $\Delta T$ , one finds:

$$\Delta T = \frac{15,000}{6 \times 10^{-6} \times 4 \times 10^6} = \frac{15,000}{24} \approx 625^\circ\text{F} \quad (7)$$
$$\Delta T \approx 330^\circ\text{C}.$$

Due to blasting both the modulus and the pillar strength will be reduced.

Possibly, the ration would remain the same so that the calculated  $\Delta T$  would still apply. Assuming a pillar height (H) of 10 ft., the thermally produced deformation would be:

$$\Delta = \alpha \Delta T H = 6 \times 10^{-6} (625) 120 \approx 0.45 \text{ ins.} \quad (8)$$

A very high heater density would be required to produce this average temperature rise in the pillar. A zone around each heater would have much higher temperatures than this and local failures would certainly occur before a general pillar failure. To understand exactly what is happening, a great

deal of instrumentation would be required as well as careful interpretation. From such a pillar study, one might be able to obtain *in situ* values for  $\alpha$  and E, which could then be used in modeling studies. This would still require careful instrumentation, data analysis and an assessment of blast influence.

## ROCK MECHANICS INVESTIGATIONS

The following types of rock mechanics investigations are recommended to measure *in situ* rock mass properties and laboratory properties.

### In Situ Measurements

CSM System. The Colorado School of Mines (CSM) Cell is a borehole instrument for measuring the *in situ* elastic modulus of rock. The cell operates by pressurizing a cylindrical membrane against the sides of an EX borehole. Data produced is in the form of a linear pressure-volume curve from which the stress-strain relationship of the rock may be determined. The cell can be used to measure *in situ* modulus in thermocouple and USBM holes, and with a new size cell, in the monitoring holes, before, during and after the heating experiments.

The main components of the CSM cell are (1) the pressure generator, (2) the pressure transducer and readout, and (3) the borehole cell (or pressurizing membrane), (figure 28).

The pressure generator serves the two-fold purpose of measuring volume reduction of the fluid system and acting as a pressure source. A thick walled cylinder tightly fitted with an internal piston, the pressure generator reduces the fluid system volume while increasing fluid pressure by feeding the internal piston through the cylinder. This piston movement is actuated by turning the rear portion of the generator. Volume displacement of the piston is conveniently determined by reducing the number of turns of the pressure generator.

The pressure transducer is a strain gaged membrane which produces an electrical output that is linear with pressure increase. The pressure

readout unit scales this output to indicate the system pressure directly in pounds per square inch on a digital display.

The borehole cell is a cylindrical adiprene membrane mounted on a stainless steel spindle and held by a threaded endcap. The membrane is 6.5 in long with an outer diameter of 1.5 in. The borehole cell is connected to the remainder of the system by high pressure stainless steel tubing.

Flatjack Experiment. A flatjack experiment has been designed to measure the *in situ* deformational, fluid flow and elastic response of a jointed rock mass. We have devised an experiment in which a variety of parameters could be measured while a large *in situ* block is subjected to known stress. Stress would be sufficient to close the larger joints so that change in the properties can be observed simultaneously as the joints closed for a wide range of load paths. The test block, figure 29, would be approximately 5 feet on a side and 5 feet deep; the vertical sides of the specimen are formed by line drilling, the bottom remains attached. The final sample is a rectangular block containing one or more joints. In each of the four slots steel flatjacks are inserted and grouted into place. A hydraulic pumping system is used to pressurize the flatjack and apply uniform loads to the sides of the specimen. Two opposite sides of the block can be loaded simultaneously, but independently of the two adjacent sides; that is, the block could be subjected to different loads in two different directions. An elastic analysis of the stress distribution in the block when loaded by a flatjack shows that stresses in the upper 2/3 of the block are quite uniform; the mechanical and fluid flow response would be measured in this part of the block. The top surface is a site for most of the measurements. The strains are measured by strain gages and by LVDT's placed across the joints. Ultrasonic velocity transducers, to measure P and S



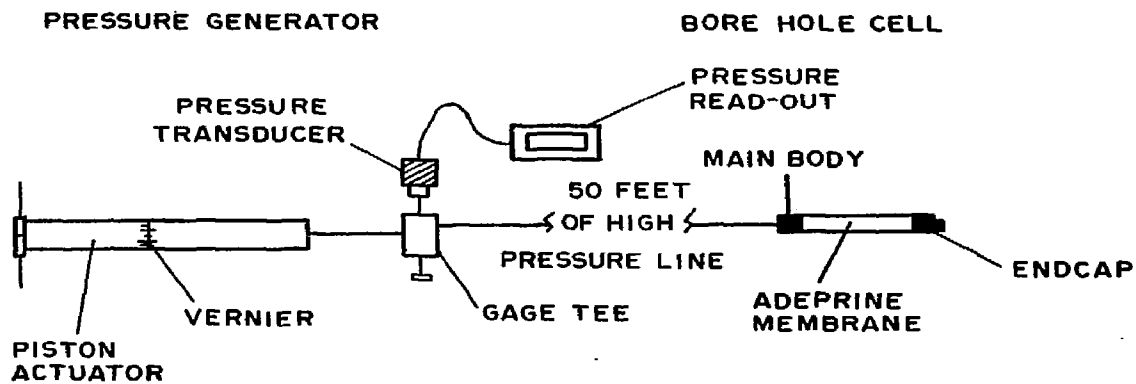

Figure 28. CSM Cell System.

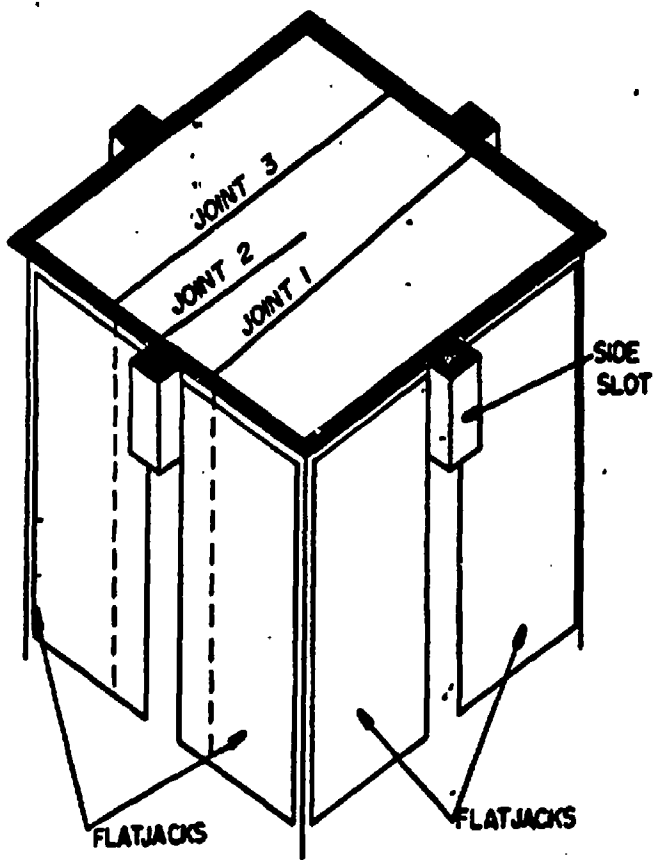

Figure 29. Flatjack Experiment.

waves velocities, are mounted on the sides of the rock in the four slots approximately 2 feet below the surface. Either fluid or air permeability can be measured along the joints between pairs of holes drilled along the joints themselves. In one case, water could be injected into one hole and flow along the joint and might be measured by using either a transient pulse technique or a steady state technique. We have had experience in using both techniques. The stress relief of the block can be observed if the block is strain gaged prior to excavation. A similar block test to the one proposed was conducted in granite in Wyoming and the data has been presented in "Elastic and Transport Properties of an *In Situ* Joint in Granite," H. R. Pratt, et al, International Journal of Rock Mechanics in Mining Science, vol. 14, p. 35-45.

Convergence Floor Tilt and Joint Displacement. The measurement of convergence, floor tilt and joint displacements both during excavation and during the heater tests are required. The elastic or nonelastic response of the roof and floor can be measured just after excavation by using either rod or tape extensometers. Floor tilt might be measured using precise leveling techniques during the heater experiments. Joint displacements might be measured during heater tests using either DCDT or LVDT assembly packages grouted to the surface of the rock.

Permeability Tests. It is recommended that both air and/or water permeability tests be conducted on major and minor discontinuities to evaluate the fluid flow response of the rock mass. Methods to measure the permeability of the rock mass would be similar to those already conducted by L<sup>3</sup>.

Acoustic Surveys. Both uphole and crosshole acoustic surveys need to be conducted in the monitor holes to measure seismic velocity. This may be one of the most sensitive indicators of changes in the fracture system during thermal loading.

### Laboratory Measurements

Laboratory measurements are needed to support both the numerical calculations and the instrumentations program. Thermal properties needed include thermal conductivity, specific heat and thermal expansion. The physical property and the mechanical tests include density, porosity, effective porosity, strength, and static and dynamic moduli. These tests should be made under confining pressure and elevated temperatures.

### EXCAVATION TECHNIQUES

The containment potential of a site can be markedly reduced by the use of poor excavation techniques. This means that very careful attention should be paid to choosing the correct drilling and blasting procedures for constructing the openings. These techniques will, in general, not be those giving the cheapest cost per foot or the most rapid construction time. It is felt that the proposed experiment should simulate the construction techniques as well as the effect of waste. The Swedes, for example, went to considerable effort to minimize blast damage to the rock.

## DRILLING SPECIFICATIONS FOR HEATER AND INSTRUMENT BOREHOLES

The drilling precision required for the subsurface instrumentation and heater holes is as follows:

The collar (starting) positions of all instrument and heater boreholes must be within  $\pm 1$  inch of the specified locations and the directions of these boreholes must be aligned to within  $\pm 0.5^{\circ}$ . The total runout or deviation of any borehole is not to exceed  $\pm 1^{\circ}$  from the planned direction. After completion each borehole starting position must be measured to an accuracy of  $\pm 3/4$  inch and the runout measured to an accuracy of  $\pm 0.5^{\circ}$ . These accuracies are relative to all other boreholes in the same experiment, and are not absolute accuracies.

To aid the drilling contractor in meeting these specifications three TP (Theodolite Points) should be provided in each drift for primary control. It is the responsibility of the contractor to perform such surveys as are needed to meet the specifications. The post drilling survey should be completed by some one other than the drilling contractor.

## RECOMMENDED BOREHOLE AND DRIFT INSTRUMENTATION

### Borehole Instrumentation

Thermocouples. The recommended thermocouples are the Chromel/Alumel type K with either a fused teflon cover capable of operation to 280°C or a 304 stainless steel sheath. The close-in thermocouples should be clad in the stainless steel sheath and capable of operation in excess of 1000°C. All thermocouples should be from the same melt as much as possible to minimize variability.

Rod Extensometer. The rod extensometer is a device for measuring change in the axial length of a borehole. The extensometer measures the displacement between downhole anchor points and the collar of the borehole. These measurements indicate extension or contraction of the rock mass in response to applied stress and thermal fields.

The rod extensometer may be divided into three principal components: (1) the measuring head; (2) the connecting rods, and (3) the borehole anchors. (Figure 30).

The measuring head is rigidly attached to the collar of the borehole and holds the DCDT transducers. The relative movement between the connecting rods and the borehole collar produced a voltage output. The ratio of change voltage multiplied by a pre-determined calibration factor indicates displacement.

The connecting rods provide a linkage between the measuring head and the borehole anchors. Any movements experienced by the anchor will be transmitted by the connecting rod to the borehole collar where it may be measured directly. To eliminate sag of the connecting rods, particularly

in horizontal holes, each rod is pretensioned to 45.5 N. A protective conduit contains the rods to prevent instrument corrosion by groundwater.

The borehole anchor provides a fixed point for mounting the connecting rods. These anchors consist of a flattened copper pipe, sealed at the ends, rolled around a retaining mandrel, and fitted with a pressure line. Once inserted in the hole, the pipe is pressurized and seated against the borehole wall. A mechanical anchor can also be used to mount the connecting rods.

USBM Borehole Deformation Gage. The USBM borehole deformation gage is a three component gage developed by the U.S. Bureau of Mines for measuring *in situ* stress. The gage measures stress indirectly by monitoring the change of three diameters, 60° apart, of an EX size (38 mm diameter) borehole.

Each diameter change is measured by a single component consisting of one pair of opposing pistons or buttons which connect the borehole wall to internally mounted cantilevers (Figure 31). Each cantilever is strain gaged near the fixed end to produce an electrical signal in response to this deflection.

The USBM gage was developed primarily for use in short term overcoring measurements of absolute stress at ambient temperatures. Use of the gage to determine long term borehole deformations as a result of high temperature fields required certain modifications in gage material and design. The modifications made for the Swedish heater experiments include:

1. construction of cantilever arms made from PH-4 stainless steel versus berillium copper,
2. use of teflon coated wiring, high temperature (304°C) strain gages, and solder,
3. elimination of tungsten carbide tips from component pistons,
4. addition of individual component bridge excitation,
5. use of teflon connector for cable to gage electrical connections,



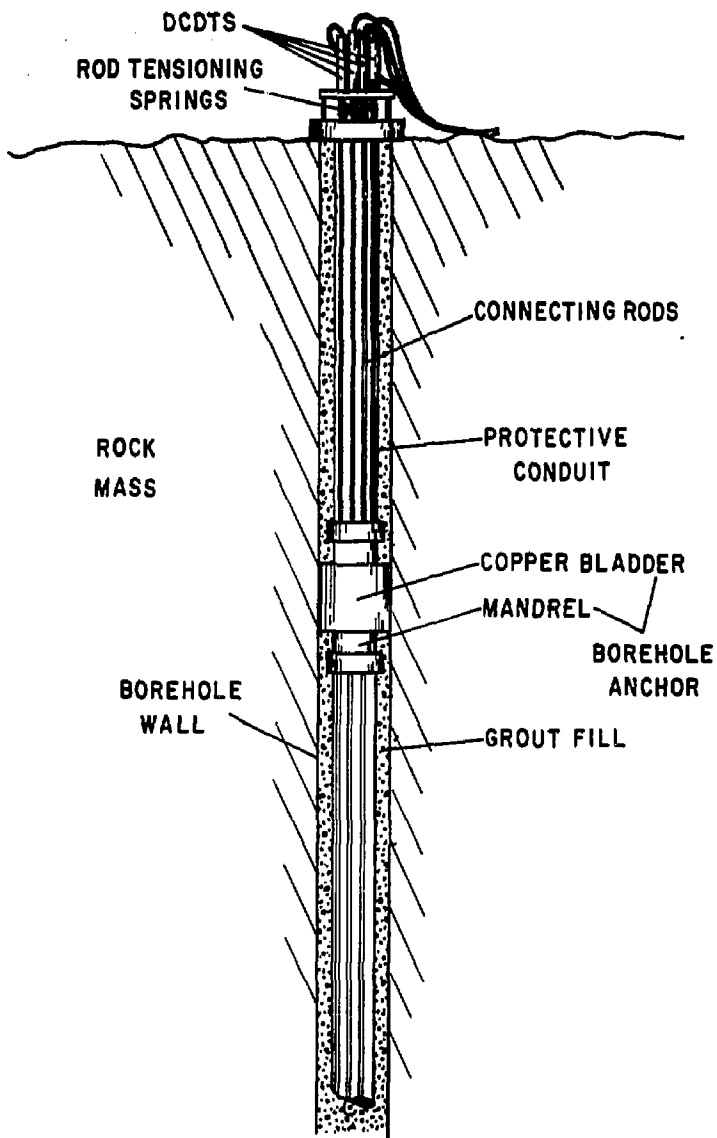

Figure 30. Schematic Drawing of Rod Extensometer.

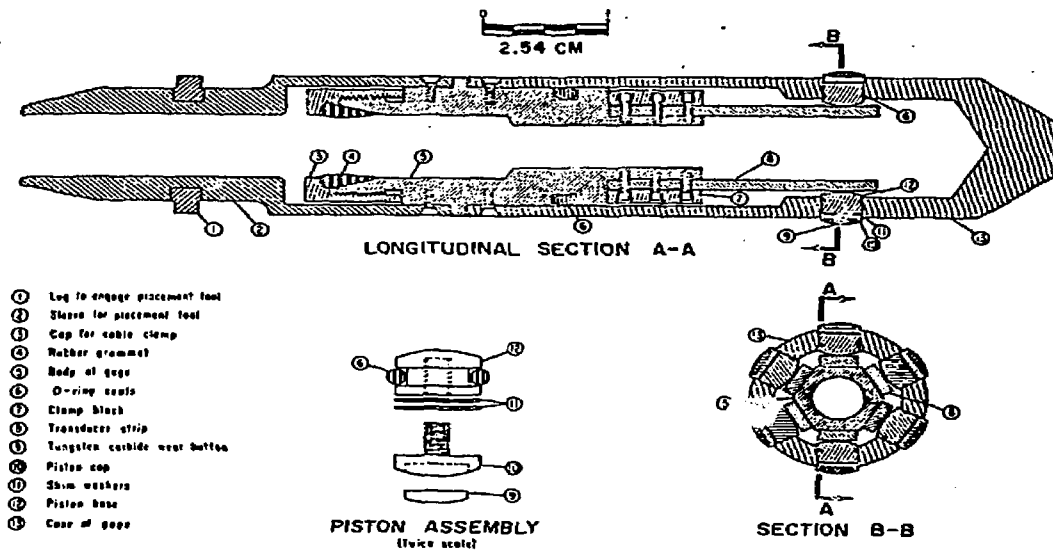

Figure 31. USBM Deformation Gauge

6. addition of a thermocouple installation hole, and
7. protection of electrical leads from water damage with RTV-60 silicone rubber compound.

The Vibrating Wire Stressmeter (IRAD). The vibrating wire stressmeter is used to directly measure thermal stress change in the rock mass as a result of heat deposition internal to the rock mass. Two stressmeters are wedged tightly in a borehole drilled in line with, or in the radial direction of the heat source. The two devices are placed adjacent and at right angles to each other and are oriented in the two principal stress directions,  $\sigma_{\theta}$ ,  $\sigma_r$  or  $\sigma_{\theta}$ ,  $\sigma_z$ , depending on a vertical or horizontal borehole.

The vibrating wire stressmeter operates on the principal that a change in stress of a wire causes a change in the fundamental period of vibration of the wire. The stressmeter consists of a hollow steel cylinder which when installed in a borehole is preloaded diametrically across the borehole by means of a sliding wedge and platen assembly shown in Figure 32.

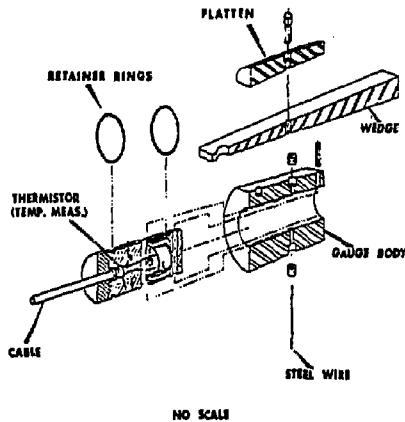

Figure 32. Vibrating Wire Stressmeter.

A highly stressed steel wire stretched across the steel cylinder and in the direction of the wedge assembly undergoes a stress change as the steel cylinder deforms from stress changes in the surrounding rock.

The change in wire stress is measured electronically by measuring the corresponding change in resonant frequency. By proper calibration of the stressmeter, the changes in wire period can be related to changes in the rock into which the gage is installed. The useful stress range of the gage is a function of the initial period of vibration with gages of low period having the greater operating range in rock with increasing compressive stresses. For the general case, three gages are required in a borehole to measure the biaxial stress changes in a plane normal to the borehole. However, if the principal stress directions are known, only two stressmeters are required for each borehole.

Drift Instrumentation. Deformations and displacements in the drift need to be measured as a function of time, both during excavation and during the heater tests. The types of instrumentation that should be used include either rod or extensometers to measure closure, MPBX extensometers to measure displacement gradients around the tunnel opening, small DCDT instrumentation packages to measure displacement of individual joints. Some thermocouples also need to be placed on the surface of the rock to get an estimation of the temperature distribution at the floor. The instrumentation for the drift is discussed more fully in the section on recommended rock mechanics tests.

Listed below is the estimated Delivery Schedule for the instrumentation.

DELIVERY SCHEDULE  
INSTRUMENTATION

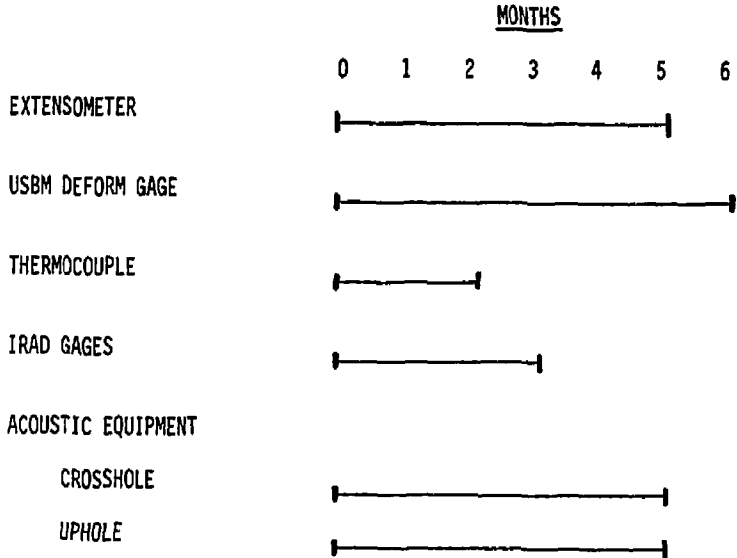

### INSTRUMENTATION COSTS

Below are listed the approximate costs for various kind of instrumentation.  
The costs do not include calibration equipment, cabling, data loggers, etc.

<u>EXTENSOMETER</u>	<u>4 ANCHOR</u>	<u>3 ANCHOR</u>
Hydraulic Anchors	\$3,000	\$2,200
Mechanical Anchors	3,500	2,600
USBM GAGE	2,000	
<u>THERMOCOUPLES</u>		
Teflon	35	
Stainless Steel Sheathed	120	
IRAD GAGE	200	

## DATA ACQUISITION AND REDUCTION REQUIREMENTS

Data acquisition and reduction requirements are an important part of the heater test program. Due to the complexity of the instrumentation and the effects of temperature changes on the instrumentation, data reduction becomes more involved than simply multiplying the voltage change by a scale factor. Additionally, the stress measuring devices (USBM gage and the vibrating wire stressmeter) require further calculation to reduce the measured quantities (borehole displacement, stress change) to a biaxial stress change. An outline of the data reduction requirements is presented for each type of transducer.

### Extensometer

Rock displacement measurements made by 4-point rod extensometers will be small and on the same order of magnitude as the thermal expansion of the invar rods. Since the DCDT's measure the sum of both displacements, it is necessary to subtract the thermal expansion of the invar rods from the total measured displacement to get the rock displacements. In order to do this subtraction, the thermal gradient along the extensometer rod needs to be known fairly accurately. Experimental measurements made at Terra Tek have shown that a linear approximation for the temperature gradient between discrete measurements of rod temperature produces a significant error, ( $\sim .003$  in/10 ft of rod). More accurate methods of determining the temperature gradients are required. A technique which is currently being used in the Sweden project makes use of cubic spline functions to interpolate the temperature data and produce a smooth curve. Figure 33 shows the spline function approximation to the temperature profile as measured by five discrete temperature measurements, A,B,C,D and E. The theoretical curve for the temperature gradient is also shown on this figure.\*

\*The theoretical temperature profile was calculated and is the rock temperature gradient approximately 3 months after heater turn on.

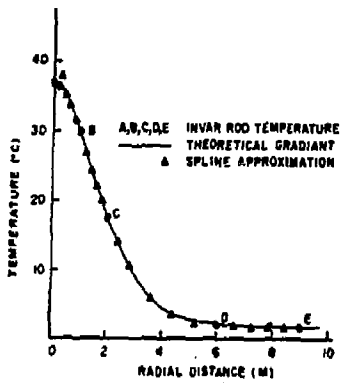

Figure 33. Cubic spline approximation to the temperature gradient as determined by the five temperatures by A, B, C, D and E.

Once the rod temperature gradient has been determined, the rod expansion can be calculated as:

$$\mu_T = \int_0^L \alpha(T) \Delta T(x) dx \quad (9)$$

$\alpha(T)$  = coefficient of thermal expansion

$\Delta T(x)$  = temperature gradient =  $T(x) - T_0$

$L$  = rod length

$\mu_T$  = displacement due to thermal expansion

For invar rod, the coefficient of linear expansion is not a constant, but is a non-linear function of temperature. Measurements of the coefficient of expansion are made in the laboratory and are used in the evaluation of Eq. 1.

In summary, the following steps need to be taken in order to calculate rock displacements from the DCDT's measurements:

- Step 1. compute the total displacement from the calibration value and the voltage change of the DCDT;
- Step 2. measure the invar rod temperatures from the attached thermocouples;
- Step 3. spline fit the temperature (Step 2) to give a smooth continuous function for the rod temperature gradient;
- Step 4. calculate the expansion of the invar rod from the temperature profile in Step 3 using the experimentally measured coefficients of thermal expansion, and
- Step 5. subtract the calculated thermal expansion (Step 4) from the total displacement (Step 1).



## USBM Gage

USBM gages measure displacement of a borehole at three points  $120^\circ$  apart. From these three measurements, the biaxial stress change can be determined. However, as in the case of the extensometer, there are temperature effects on the gage which must be taken into account. The first effect is a small change in calibration factor with temperature. Measurements made in the laboratory show this change to be repeatable and on the order of 6%. Additionally, an offset voltage is generated when the gage undergoes a change in temperature at constant displacement. The offset voltage is linear with temperature, but the magnitude is gage dependent. Thus, this offset voltage must be measured for each gage. Figure 34 shows this effect.

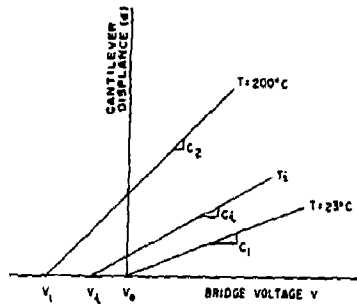

Figure 34. Calibration curves as a function of temperature for the USBM gages.

A third effect that temperature changes has on the displacement measurements is to generate an output voltage (indicated borehole displacement) due to differences in the coefficient of thermal expansion between the rock and the gage. This displacement must be subtracted from the final calculated displacement. Once the correct displacements have been determined, the biaxial stress components can be calculated from the equations of elasticity. Figure 35 shows the orientation of the principal stress components in relation to the three displacement components.

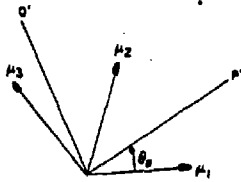

Figure 35. Displacements measured by USBM gages.

The quantities  $u_1$ ,  $u_2$  and  $u_3$  are the displacements measured by the USBM gages. The first displacement  $u_1$  will always be oriented in the  $\theta$  direction for both horizontal and vertical holes. The biaxial stress components  $P'$  and  $Q'$  are the principal stresses. From symmetry the angle  $\theta_p$  should be close to  $0^\circ$  or  $90^\circ$ , depending on the magnitude of  $P'$  and  $Q'$ . If the angle  $\theta_p$  turns out to be near  $0^\circ$  ( $\pm 10^\circ$ ) then the principal stress component  $Q'$  becomes  $\sigma_r$  or  $\sigma_z$ , depending on if the hole is vertical ( $\sigma_r$ ) or horizontal ( $\sigma_z$ ). The equations of interest are:

$$P' = \frac{E}{(1-\nu^2)6d} \left\{ (u_1+u_2+u_3) + \frac{\sqrt{2}}{2} \left[ (u_1-u_2)^2 + (u_2-u_3)^2 + (u_3-u_1)^2 \right]^{1/2} \right\} \quad (10)$$

$$Q' = \frac{E}{(1-\nu^2)6d} \left\{ (u_1+u_2+u_3) - \frac{\sqrt{2}}{2} \left[ (u_1-u_2)^2 + (u_2-u_3)^2 + (u_1-u_3)^2 \right]^{1/2} \right\} \quad (11)$$

$$\theta_p = \frac{1}{2} \tan^{-1} \left[ \frac{\sqrt{3} (u_2-u_3)}{2u_1-u_2-u_3} \right] \quad (12)$$

Since  $\theta_p = 0^\circ$ , then  $P' = \sigma_\theta$  and  $Q' = \sigma_r$  or  $\sigma_z$ , depending on vertical or horizontal holes.

Software requirements for the USBM gages can be summarized as follows:

- Step 1. measure the temperature of the USBM gage and compute the calibration curve for that temperature;
- Step 2. calculate the three borehole displacements from the calibration curve determined in Step 1, and
- Step 3. subtract off the displacement due to the differences in coefficients of expansion between the rock and the steel gage.

## Vibrating Wire Stressmeters

The vibrating wire stressmeter is used to directly measure the biaxial stress change in the rock mass as a result of induced thermal stresses. Two stressmeters are placed adjacent and at right angles to each other in the borehole, and are oriented in the two principal stress directions  $\sigma_\theta$ ,  $\sigma_r$  or  $\sigma_\theta$ ,  $\sigma_z$ , depending on vertical or horizontal holes. The stressmeter operates on the principle that a change in stress of a wire causes a change in the fundamental period of vibration of the wire. A highly stressed steel wire stretched across the steel cylinder and in the direction of the wedge assembly undergoes a stress change as the steel cylinder deforms from stress changes in the surrounding rock.

The vibrating wire stressmeter is a nonlinear device which can change calibration in rock as the temperature changes. Experiments performed at Terra Tek in the Swedish granite rock show a change in calibration as a function of temperature. Typical calibration curves for the vibrating wire stressmeters are shown in Figure 36.

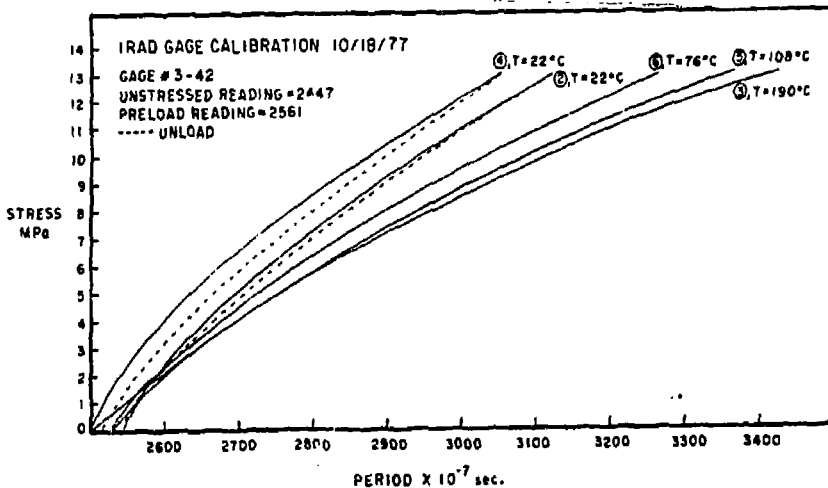

Figure 36. Typical calibration curves for vibrating wire stressmeters.

Laboratory experiments on vibrating wire stressmeters have shown that the calibration curve can be described well with an equation of the form:

$$\Delta\sigma (R,T) = C_1 (T) \left[ \frac{1}{(R + \Delta R)^2} \right] + C_2 (T) \quad (13)$$

where:  $C_1 (T)$  and  $C_2 (T)$  are laboratory determined coefficients and are functions of temperature

T = Temperature

R = Gage Reading

$\Delta R$  = Offset Reading.

Once the stress changes for each gage has been calculated from Eq. (5), the biaxial stress changes can be computed from the equation of elasticity, e.g.,

$$\sigma_\theta = \frac{9}{8} \Delta \sigma_\theta + \frac{3}{8} \Delta \sigma_r \quad (14)$$

$$\sigma_r = \frac{9}{8} \Delta \sigma_r + \frac{3}{8} \Delta \sigma_\theta \quad (15)$$

$$\sigma_\theta = \frac{9}{8} \Delta \sigma_\theta + \frac{3}{8} \Delta \sigma_z \quad (16)$$

$$\sigma_z = \frac{9}{8} \Delta \sigma_z + \frac{3}{8} \Delta \sigma_\theta \quad (17)$$

In summary, the following steps outline the data reduction steps required to compute biaxial stress changes:

Step 1. measure the temperature (T) and reading (R) of each gage;

Step 2. calculate the new calibration coefficient  $C_1 (T)$  and  $C_2 (T)$  and evaluate the stress change  $\Delta\sigma_\theta$ ,  $\Delta\sigma_r$ ,  $\Delta\sigma_\theta$ , depending on vertical or horizontal holes;

Step 3. from the equation of elasticity, calculate the biaxial stress change;

Step 4. from the three displacement measurements (Step 3), compute the biaxial stress change.

## Thermocouples

Type K thermocouples when ordered from the same melt have a minimum variation in calibration and can be converted to temperatures from the NBS Tables. Rather than store the NBS Tables in a computer for interpolation, it is more appropriate to fit a polynomial to the table and use this polynomial to evaluate the temperature. A standard error of less than  $0.1^{\circ}\text{C}$  can be achieved by fitting a 4th order polynomial to the NBS tables from  $0-300^{\circ}\text{C}$ . For higher temperatures, a second polynomial is suggested over the range  $300^{\circ}\text{C} - 600^{\circ}\text{C}$ . Data reduction software requires the evaluation of a 4th order polynomial given the voltage reading of the thermocouple.

In addition to the software required to convert voltages from the transducers into engineering units, there must be a general purpose calibration routine to calibrate the transducers on site. This routine would be used to get the calibration values for the USBM gages and the extensometer DCDT's. Secondly, consideration needs to be given to long term data storage, retrievability of data for plotting and editing routines to input and edit calibration files.