

2
HFR REPORT No. 99: FAST LEAK OF A CHANNEL FILLED WITH HELIUM AT A PRESSURE OF
2 BARS (CHANNEL H5),

Received by ACTJ

AUG 04 1987

By E. Bauer and J. Tribolet

Report EB-JT/od-82-2, dated Feb. 7, 1982, Max Von Laue - Paul Langevin
Institute.

BNL-tr--1059

TABLE OF CONTENTS

DE88 001467

1. PURPOSES
2. REVIEW
 - 2.1. Placement of horizontal channels
 - 2.2. Cooling Circuits
 - 2.3. Equipment of an Exiting Beam Channel (H5)
3. FAST LEAK
 - 3.1. Failure Mode and Calculation Hypothesis
 - 3.2. Sequence of Events
 - 3.3. Consequences For Structures
 - 3.4. Path of Helium that Has Left the Channel
 - 3.5. Evacuation of Residual Power
 - 3.6. Status of the Reactor After Establishment of Stable State
4. SUMMARY

MASTER

DISTRIBUTION OF THIS DOCUMENT IS UNLIMITED

f2

1. PURPOSE

The purpose of the present report is to analyse the progress of a fast leak that takes place in a helium-filled channel and its resulting consequences.

Analysis was done for the case of channel H5 which has the largest available volume of all of the helium-filled channels. However, the results produced by the H5 can be transposed to other channels by considering the specificity of each case without the sequence of events changing its nature.

2. REVIEW

2.1. Placement of the Horizontal Channels

Figure 1 shows a simplified drawing of the reactor with a horizontal channel. The reflecting can, filled with heavy water and containing the fuel element, is submersed in a pool of light water, itself delimited on the exterior by walls with a concrete center core, covered with a stainless steel lining. The can has extrusions, connected to sleeves that assure containment of the heavy water with respect to the pool and to the experimental zones of the reactor building. The channels penetrate the reflecting can through the collars, with the heavy water being contained between the collar and the channel.

The heavy water cooling the fuel element circulates in the tubes across the bottom of the pool. The arrival line is connected to the center stack, closed at the top by the reactor valve; the departure line is connected to the suction basket placed at the top of the reflecting can. The siphon-breaking

shutter (CS) connects the arrival line to the crosshead of the departure line. The three natural convection shutters CN1, CN2 and CN3 open in case the pumps stop, allowing evacuation of the residual power of the fuel element by natural convection.

A portion of the heavy water flow that handles cooling of the control rod circulates through tubing that is connected to the tail of the reflecting can. The natural convection shutter (CB) that allows cooling of the control rod by natural convection is connected to the Reactor Coolant Shutdown Rod (CRAB) departure line downstream from the crosshead.

2.2. Cooling Circuits

Figure 2 gives a basic schematic drawing of the primary D₂O circuits. The main pumps, whose shaft has a flywheel, discharge the heavy water through the principal exchangers placed in parallel in the central stack of the reflecting can. The water that has traversed the channels between the plates of the fuel element slowly rises into the reflecting can up to the suction basket. The portion of the flow taken into the fuel element for cooling of the control rod passes through the circuit called CRAB (Shutdown Rod, Cooling Circuit) toward the "shutdown rod" pumps that discharge through the shutdown rod exchanger in the arrival line of the principal circuit.

The natural convection shutters CN and CB, as well as the siphon breaker shutter CS, are closed by the action of the shutdown rod pumps. They are kept closed either by the high pressure in the arrival line in the principal circuit (CN and CS) or by the pressure in the Reactor Coolant Shutdown Rod (CRAB) departure line (CB).

The pressurization pumps discharging into the departure line of the main circuit give the water a pressure of 4 bars absolute in the center plane of the core.

After the reactor and the main pumps have stopped, evacuation of the power is assured by the shutdown rod pumps alone, by opening of the check valve which connects the main circuit with the CRAB circuit.

2.3. Equipment for an Exiting Beam Channel (H5)

Figure 3 shows the major equipment of an exiting beam channel. Inside the channel, whose diameter decreases from the strap to the thin bottom, is placed a plug equipped with a collimator with an entry window. The plug is locked into the thick parts of the channel with locking shims. The housing extending towards the safety valve to the exit window is sealed to the channel strap. The low point of the housing is equipped with moisture detection plugs.

The spacer between the safety valve and the exit window has an opening to the isolation valve that makes it possible to create a vacuum in the channel or to add helium.

During reactor operation, the safety valve is always open. However, the space delimited by the channel remains contained by the channel itself, the housing and the exit window. In case the channel breaks, the presence of heavy water is detected by the moisture detection plugs placed in the housing. They cause the safety valve to close.

3. FAST LEAK

3.1. Defect Mode and Calculation Hypothesis

Let us consider the failure of channel H5 under the following conditions:

- the reactor is operating normally,

- the heavy water pressure in the channel is held at 4 bars absolute, the safety valve is open, the helium pressure in the channel is 2 bars absolute.

The failure suddenly opens up the entire cross section of the front part of the channel at the point of connection between the cylindrical ferrule and the thin bottom. The heavy water enters the channel in the form of a piston accelerated by the pressure differential between the inside and the outside.

Calculations have been made to trace the results of these events. The following hypotheses have been chosen:

- The entrance orifice has a cross section with a diameter of 100 μm ,

- the heavy water is a perfect liquid with a constant density and without viscosity,

DISCLAIMER

This report was prepared as an account of work sponsored by an agency of the United States Government. Neither the United States Government nor any agency thereof, nor any of their employees, makes any warranty, express or implied, or assumes any legal liability or responsibility for the accuracy, completeness, or usefulness of any information, apparatus, product, or process disclosed, or represents that its use would not infringe privately owned rights. Reference herein to any specific commercial product, process, or service by trade name, trademark, manufacturer, or otherwise does not necessarily constitute or imply its endorsement, recommendation, or favoring by the United States Government or any agency thereof. The views and opinions of authors expressed herein do not necessarily state or reflect those of the United States Government or any agency thereof.

- there are no effects of inertia when the water is moved or speeded up,
- there is no shrinking effect of the [water] jet at the point of the entrance orifice.
- the flow rate of the pressurization pump is so low (approx. 7 l/s) that their role can be neglected in the case very rapid phenomena exist.

Given the exclusion of any phenomena of friction, the results of calculation are relative to an unfavorable case in which the phenomena take place faster than they actually do in reality.

The equations used to calculate the problem are given in the appendix. The results are presented in tables I and II which give the flow rate at the entrance orifice U , the volume of water entering the channel during the time lapse Δt , the volume V that entered the channel since the failure, the pressure p_a in the reflector can at the level of the axis of channel H5 and the pressure p_i in the channel.

3.2. Sequence of Events

The leak water compresses the helium contained in the channel. Calculation was performed with the hypotheses of both isothermal (Table I) and adiabatic (Table II) compression.

Comparison of the results entered on the tables shows that the numbers are almost the same if one compares statuses related to the same time frame up to about 60 ms from failure.

The differences between the two modes of compression begin to be noticeable after about 70 ms. The increase of p_i is greater and the instant rate is smaller in the case of adiabatic compression than in the case of isothermal compression. In view of the hypotheses accepted in order to simplify mathematical calculation, the results of these two modes of calculation can be considered equal. Given the fact that the final pressure is 2.32 bars instead of 2.50 bars, the description of the sequence of events below will be based on isothermal compression.

$t_0 = 0$ Loss of seal. Cross section at point of entrance orifice: 0.0079 m^2 .
Entry velocity: 19.1 m/s
Instant Flow rate: 150 l/s.

To the extent that the water enters the channel, the static pressure in the reflecting can drops at the rate of 1 bar/12.5 l [l] and the helium pressure in the channel increases. The entry velocity decreases gradually.

$t_1=55$ ms Pressure in the reflector can: 3.4 bars

Rod drop order.

Main pump shutdown order

Volume of water that has entered channel: 7.5 l

Instant flow rate: 123 l/s

Entry velocity: 15.7 m/s

The flywheels mounted on the shafts of the main pumps assure a slow decrease of the flow rate after the pump shutdown order. Figure 4 shows the decrease of flow rate as a function of time. After 4 seconds, the flow rate is still equal to 70% of the nominal rate; after 40 seconds, it is still equal to about 20%.

The first particles of water that entered at $t_0 = 0$ at a rate of 19.1 m/s have covered a distance of 1.05 m.

$t_2=130$ ms Pressure in the reflecting can: 2.79 bars

Helium pressure in channel: 2.22 bars

Entry velocity: 10.5 m/s

Instant flow rate: 82 l/s

Volume of water that has entered channel: 15.1 l.

The first particles of water that entered at $t_0=0$ have reached the entry membrane.

$t_3=265$ ms Pressure equilibrium between heavy water in reflector can and channel
helium

Pressure: 2.32 bars.

Volume of water that has entered channel: 21 l.

$t_3 = 265$ ms marks the end of the first phase of flow that is characterized by a pressure drop in the reflector can, a pressure increase in the channel and a gradual decrease in the flow rate of the leak water.

The second phase that follows is characterized by a slow flow that is called "free." A quantity of water entering the channel leads to the replacement of a quantity of helium occupying the same volume. It is a two-phase flow that is established with the helium leaving the channel near the upper generatrix, against the current of the water that is entering the channel.

A simple calculation (see Appendix: Free Flow) assimilating the flow of the leak water at the level of the flow orifice above a spillway makes it possible to locate the order of magnitude of the leak rate in this regime. Assuming that the proportion of the entrance cross section occupied by the helium, in comparison the the surface occupied by the water, is between 0.9 and 0.7, the corresponding rates are between 6 and 4 l/s.

As the channel fills, the model of the spillway becomes increasingly less realistic, given the depth of the layer of water present in the channel.

The end of the second phase of leakage in a free flow regime is reached when the water occupies the entire lower part up to the upper generatrix of the entry orifice, with the upper part being filled with helium.

Considering the interior volume of the channel and the volume occupied by the plug/collimator, the volume of water that has entered by the end of the second phase of leakage can be estimated at approximately 100 l.

Without assigning numbers to the time it takes the channel to fill, it is possible to give the sequence of events.

$$t_4 = t_1 + 250 \text{ ms} = 305 \text{ ms}$$

Stoppage of the chain reaction.

Filling of the channel by free flow continues.

t_5 The leak water arrives at the moisture detection plug. Filling of the channel by free flow continues.

$$t_6 = t_5 + 10 \text{ s}$$

Closure of the safety valve.

Filling of the channel by free flow continues.

t_7 End of the second phase of leakage in free flow regime.
The channel is filled to the upper generatrix of the leak orifice. There is a pressure equilibrium between the reflector can and the inside of the channel. The volume of water that has entered the channel is approximately 100 l. The volume of helium at the top of the channel is approximately 50 l.

After that, the action of the pressurization pumps leads to an increase of the pressure in the system up to approximately 4 bars. As the pressure increases,

the volume of helium is compressed and water enters the channel as necessary to maintain the equilibrium between the reflector can and the channel.

3.3 Consequences for the Structures

The time required for the first water particles to encounter the exit window is $t = 260$ ms. A free horizontal jet, subjected to gravity, experiences a drop of approximately 34 cm in 260 ms.

Consequently, it is not probable that the leak water directly encounter the orifice of the safety valve or the exit window ($e = 1$ mm) from the free spray. Even in the absence of the entry window, the water spray would graze the walls of the passageway and filling would take place with more or less free flow, without an noticeable force on the exit window or the safety valve.

Therefore, at the point of the rear channel flanging, the consequences of a fast leak are negligible, given the absence of rapid dynamic phenomena and the good mechanical strength of the membranes [2]. The leak water remains contained within the volume delimited by the channel walls, the housing and the safety valve/exit window.

3.4 Path of the Helium that has Left the Channel

When the channel is filling, a free flow (second phase) ($t > t_3 = 265$ ms) of the helium escapes from the channel in the form of bubbles rising up. Assuming that the model of the spillway (see appendix) is realistic at the beginning of the second phase, the flow rate of gas entering the reflector can is 4 to 6 l/s.

A portion of this volume of helium is aspirated with the water by the suction basket; the other part, escaping aspiration by the suction basket, accumulates at the top of the reflector can, below the upper structure. It should be noted that the helium cannot get into the Reactor Coolant Control Rod (CRAB) departure line (see Fig. 1) given the fact that this line is connected to the tail of the reflector can that is lower than the channel.

The helium aspirated by the suction basket follows the current towards the crosshead, then the vertical line where the bubbles tend to rise against the current of the water. The relative velocity between the gas bubbles and the liquid depends largely on the bubble size [3], as well as the nature of the fluids and on the gas/liquid ratio [4]. The maximum velocity between an air bubble and ordinary water is approximately 30 cm/s for bubbles approximately 2 mm in diameter. Smaller bubbles move more slowly; so do larger bubbles, with a tendency, depending on the flow regime, to disintegrate into smaller bubbles.

The result is that all the gas bubbles are carried with the water into the departure line, as long as the speed there is over about 30 cm/s, which corresponds to a flow rate of 38 l/s, or 136 m³/h.

The flow rate at the shutdown regime of the reactor, with the CRAB circuit operating, is 150 m³/h [5] and exceeding this value with main pumps operating. This means that the entire volume of the helium aspirated by the suction basket is carried off by the water towards the pumps.

The helium going through the pumps in the form of a more or less fine dispersion is discharged into the exchangers placed horizontally with the holes disposed laterally.

The gas arriving at the exchangers will accumulate in the upper part in compartments formed by vertical baffles and the exterior ferrule. The cooling conditions of the fuel element will not be modified.

The helium accumulating above the upper structure has a tendency to rise in the water layers surrounding the equipment placed in this place. It goes into the return line to the expansion vessel and, after the gas is removed from the water, is in the gaseous plenum of the vessel.

3.5. Evacuation of the Residual Power

When the pressure of 3.4 bars is reached in the reflector can, orders to drop the rods and stop the main pumps are given. The flywheels of the main pumps assure a gradual decrease of the flow rate through the fuel element until the check valve connecting the main circuit and the CRAB circuit opens and the evacuation of the residual power is assured by the CRAB pumps alone. Assuming that the addition of water due to the pressurization pumps is always negligible, the pressure p' of aspiration of the pumps can be determined by the sum of the pressure in the reflecting can $p_a = 2.3$ bars (t_3) and the hydrostatic pressure due to the water column approximately 9 m high: $p' = 3.3$ bars (head loss neglected). This pressure, much higher than the minimum allowable suction pressure, assures the absence of cavitation in the pumps.

Consequently, evacuation of the residual power is done under conditions close to the usual conditions after a normal shutdown.

When the pressure in the reflecting can drops, the flow rate of the pressurization pumps increases depending on the characteristics of the pumps. On the other hand, the discharge velocity into the return line to the expansion vessel decreases. The result is an addition of water to the reflector can which leads to a gradual pressure rise until the usual pressure level of 4 bars is reached. During this pressurizing time, cooling of the fuel element takes place under unchanged conditions.

3.6. Status of the Reactor after Establishment of a Stable State

After the large leak into the helium-filled channel, the pressure drops to approximately 2.3 bars in the reflector can and gradually rises again to 4 bars. Repressurizing is governed by the action of the pressurization pumps that replace into the circuit the volume of water required to compensate for the removal opposite the leak orifice (approximately 120 l, considering the compression of the helium remaining in the channel). A portion of the helium is in the upper parts of the main exchangers, the other part rejoins the gas forming the plenum of the expansion vessel. Assuming that half of the gas that has escaped from the channel is in the exchangers, the volume occupied by the helium is about 20 l, considering the pressure of about 6 bars in that location.

Cooling of the fuel element is done under usual shutdown conditions. The siphon breaker valves CS and natural convection valves (CN and CB) are closed.

The quantity of water coming from the expansion vessel required to reestablish the usual pressure level is between about 120 and 100 l, depending on the distribution of the helium in the circuit selected. This corresponds to a level variation from 15 to 12 cm, a variation that is compatible with maintaining the cooling circuits in operation.

4. Abstract

The loss of seal of a helium-filled channel (H5) opening the entire cross section of the front part leads to a fast leak. The channel fills to the upper generatrix of the leak orifice and part of the helium contained in the channel escapes into the circuit.

The pressure drop in the reflector can lead to reactor and main pump shutdown. On the other hand, the Cooling Circuit Shutdown Bar circuit pumps remain in operation.

Dynamic effects are limited to the front part of the plug since the water jet entering the channel is broken before it reaches the safety valve and the exit window.

The leak water remains confined in the channel because of the strength of the exit window and closing of the safety valve.

The helium that has left the channel when it filled with water accumulates in the expansion vessel and in the top parts of the exchangers.

The pressurization pumps cause the pressure in the circuit to rise until the usual level of 4 bars is reached in the reflector can.

During all of the transient phases provoked by the fast leak, the CRAB pumps remain in operation. Evacuation of the residual power is assured under normal flow rate conditions.

REFERENCES

- [1] ASTRUC, J.M.: Proposal for the Improvement of the HFR Heavy Water Pressurization System.
Internal HFR Note No. 42 a dated Dec. 8, 1977.
- [2] TRIBOLET, J.: Test Report No. 38: Strength of A G3 Membranes
JT/OD-81-38 Nov. 20, 1981
- [3] PEEBLES and GARBER, Chem. Eng. Progr. 49 (1953)
- [4] HOUGHTON, McLean and Ritchie, Chem. Eng. Sci., 7 40 (1957)
- [5] HFR Safety Report (paragraph 241.1.1.)

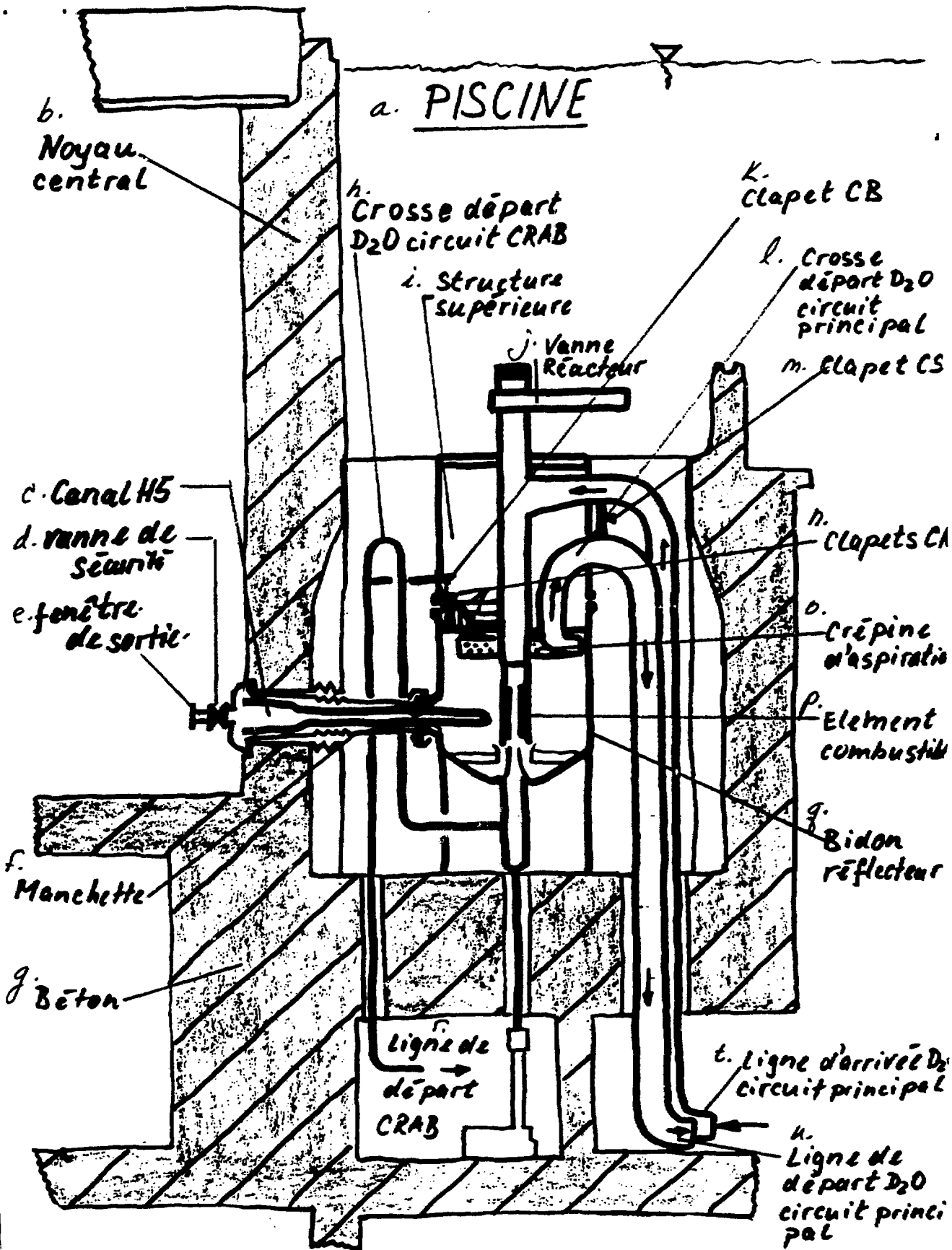

Figure 1: Drawing of Reactor with H5

Key:

- | | |
|----------------------------------------------------------|----------------------------------------------------|
| a. POOL | k. CB Shutter |
| b. Center core | l. D ₂ O Depart crosshead, main circuit |
| c. H5 Channel | m. CS Shutter |
| d. Safety Valve | n. CN Shutters |
| e. Exit window | o. Suction basket |
| f. Collar | p. Fuel Element |
| g. Concrete | q. Reflector can |
| h. Departure crosshead,
CRAB D ₂ O circuit | r. CRAB departure line |
| i. Upper Structure | s. Reflector can |
| j. Reactor Valve | t. D ₂ O arrival line, main circuit |
| | u. D ₂ O departure line, main circuit |

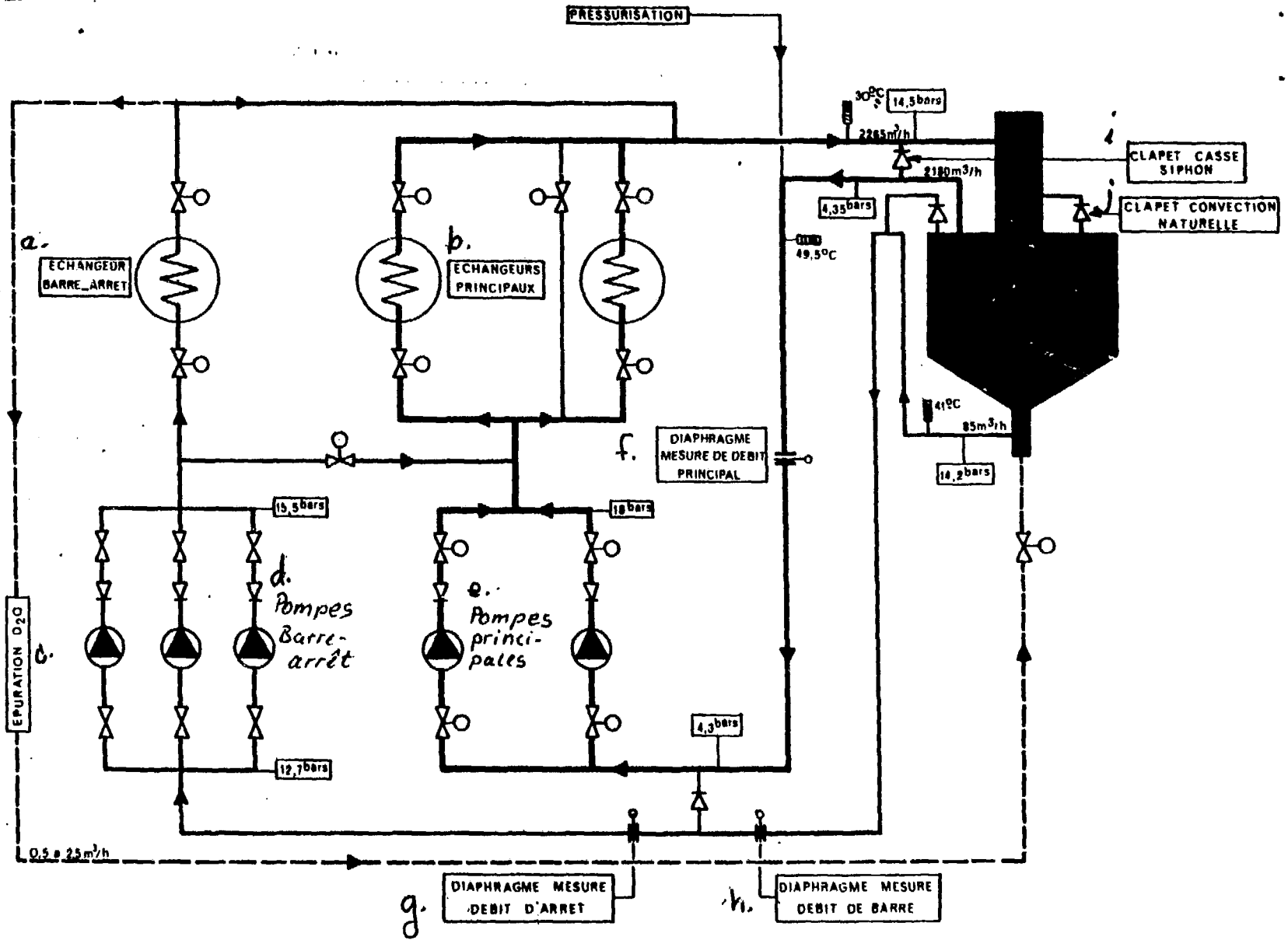

Fig. 2: SCHEMA DE PRINCIPE DES CIRCUITS PRIMAIRES D₂O

Figure 2: Schematic of D₂O Primary Circuits

- Key:
- | | |
|----------------------------------|-------------------------------------|
| a. Exchanger, Shutdown Rod | f. Diaphragm, Main flow measurement |
| b. Main exchangers | g. Diaphragm, shutdown flow measure |
| c. D ₂ O Purification | h. Diaphragm, rod flow measurement |
| d. Pumps, Shutdown Rod | i. Siphon-breaker valve |
| e. Main pumps | j. Natural Convection Valve |

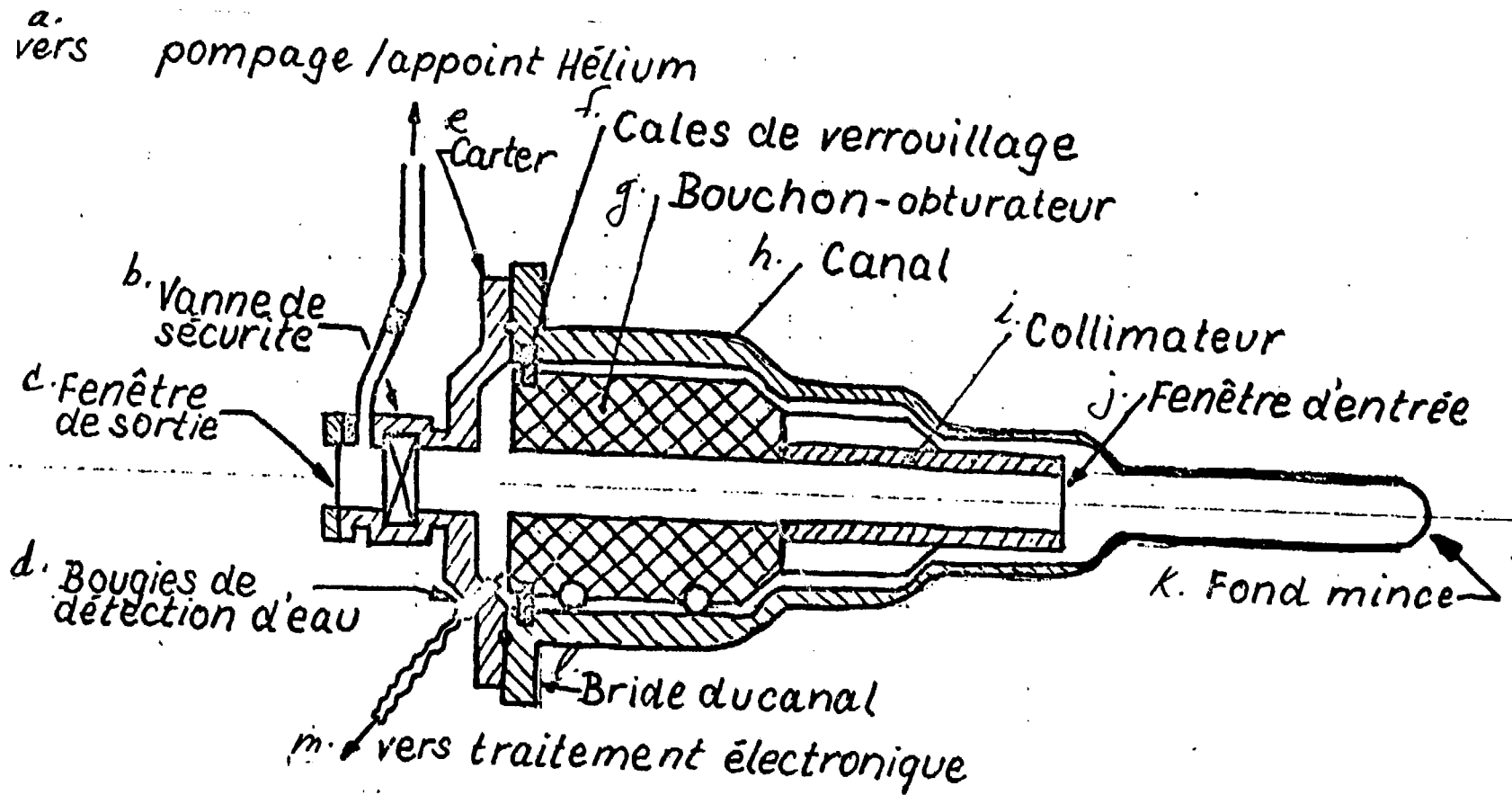

Fig. 3 Equipement d'un canal "à faisceau sortant"

Fig. 3: Equipment of an "Exiting Beam" Channel

Key:

- | | |
|-----------------------------|-----------------------------|
| a. To pumping/helium fill | h. Channel |
| b. Safety Valve | i. Collimator |
| c. Exit Window | j. Entry Window |
| d. Moisture Detection Plugs | k. Thin End |
| e. Housing | l. Channel strap |
| f. Locking Shims | m. To Electronic processing |
| g. Plug | |

Figure 4: Decrease of Flow rate of Main Pumps After Shutdown

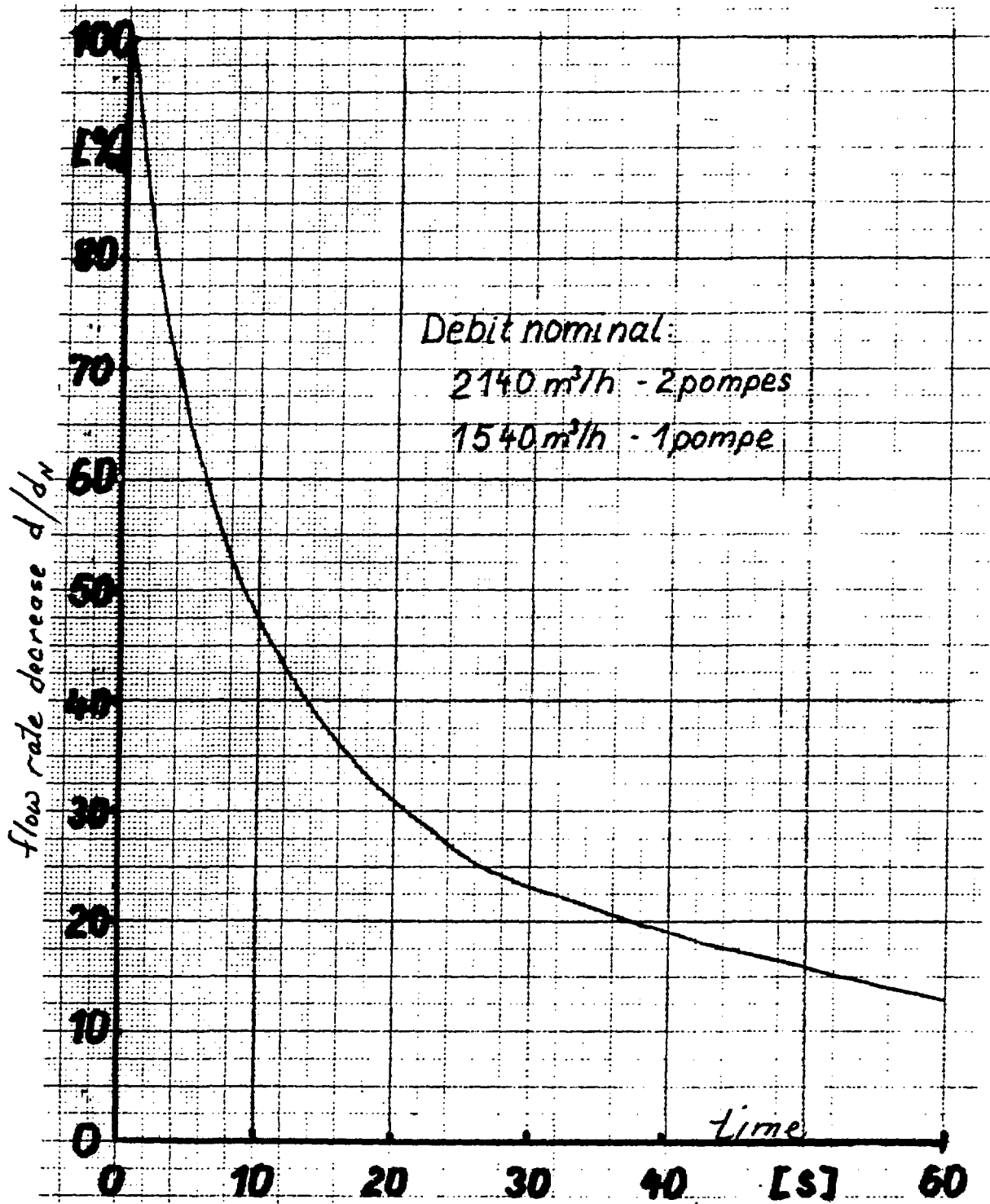

APPENDIXCALCULATION OF LEAK PROGRESSNotations

- t = Time
- ρ = Density of heavy water ($1,100 \text{ kg/m}^3$)
- S = Cross section of channel entrance (Channel H5: $S = 78.5 \text{ cm}^2$)
- V_c = Volume available in channel (Channel H5: $V_c = 150 \text{ l}$)
- V = Volume of heavy water extracted from reflector can
- p_a = Heavy water pressure in reflector can
- p_{a0} = Heavy water pressure in reflector can during normal reactor operation ($p_{a0} = 4 \cdot 10^5 \text{ N/m}^2$)
- p_i = Helium pressure in channel
- p_{i0} = Helium pressure in channel during normal reactor operation ($p_{i0} = 2 \cdot 10^5 \text{ N/m}^2$)
- U = Entry velocity of heavy water into channel
- γ = Ratio of heat capacities C_p/C_v ($\gamma = 1.67$ for helium)

When the instant t at which the various parameters are being considered, the notations retain the same meaning but are completed as follows: $V(t)$, $p_a(t)$, $p_i(t)$, $U(t)$

Appendix1. FORCED FLOW ($p_a > p_i$)1.1. Writing the Equation

According to the test report: "Pressurization of the D₂O Circuit", the pressure p_a in the heavy water follows a linear law as a function of the volume V removed from the reflector can (1 bar of pressure drop for 12.5 l removed). The equation of this law is written as follows in SI-Units:

$$p_a = \frac{-V}{12.5 \cdot 10^{-3}} \times 10^5 + 4 \times 10^5$$

or:
$$p_a = -8 \cdot 10^6 V + 4 \cdot 10^5 \quad (1)$$

The helium compression is governed by the equation:

-- In adiabatic mode:

$$p_{i0} V_c^\gamma = p_i (V_c - V)^\gamma$$

or:
$$p_i = p_{i0} \frac{V_c^\gamma}{(V_c - V)^\gamma} \quad (2)$$

-- In isothermal mode:

$$p_{i0} V_c = p_i (V_c - V)$$

or:
$$p_i = p_{i0} \frac{V_c}{(V_c - V)} \quad (3)$$

The general equation for the movement of a non-compressible fluid (σ constant) of nil viscosity ($\mu = 0$) along the line of current is:

$$\vec{\text{Grad}} \left(\frac{1}{2} U^2 + \frac{P}{\rho} \right) = \vec{f} - \frac{\partial \vec{U}}{\partial t} \quad (4)$$

with: \vec{U} = Fluid speed
 p = static pressure of fluid
 ρ = Density of fluid
 \vec{f} = External force

In the case of the horizontal channel H5, the external force \vec{f} is nil. The general equation (4) of the movement of the heavy water becomes:

$$\vec{\text{Grad}} \left(\frac{1}{2} U^2 + \frac{P}{\rho} \right) = - \frac{\partial \vec{U}}{\partial t} \quad (5)$$

The flow regime is not stationary since the pressures inside the reflector can and the glove finger are not constant in time and, consequently, the following term is not nil:

$$\frac{\partial \vec{U}}{\partial t}$$

Since integration of the differential equation (5) is difficult, we shall simply evaluate the value of the velocity of the permanent regime that the instant values of the pressures p_a and p_i , which are considered constant, would lead to during the small interval Δt . By doing this, we neglect the inertia of the system. In this case, equation (5) is written as follows:

$$\vec{\text{Grad}} \left(\frac{1}{2} U^2 + \frac{P}{\rho} \right) = \vec{0}$$

or:
$$\frac{1}{2} U^2 + \frac{P}{\rho} = \text{Cte}$$

and since ρ is constant:

$$P + \frac{1}{2} \rho U^2 = \text{Cte} \quad (6)$$

The current lines arise in the reflector can where the pressure is p_a and the velocity of the heavy water is practically nil. Along these lines, the static pressure of the heavy water decreases from the value p_a to the value p_i which is reached at the entrance to the channel, where the velocity is U . Equation (6) is then written:

$$\begin{array}{lcl} p_a + 0 & = & p_i + \frac{1}{2} \rho U^2 \\ \text{Reflector can} & & \text{Channel entrance cross section} \end{array}$$

or:
$$U = \sqrt{\frac{2}{\rho}} \sqrt{P_a - P_i} \quad (7)$$

The volume ΔV having penetrated the channel with a cross section of S during the time interval Δt , at which time all the magnitudes are considered constant, is as follows:

$$\Delta V = S \cdot U \cdot \Delta t \quad (8)$$

1.2. Calculations

With equations (1), (2) or (3), (7), (8) it is possible to solve the problem of forced flow by a step-by-step calculation (step size Δt), a schematic of which is indicated below:

Time interval $[t - \Delta t, t]$ Time interval $[t, t + \Delta t]$

$U(t) = \sqrt{\frac{2}{\rho}} [p_a(t-\Delta t) - p_i(t-\Delta t)]^{1/2}$	$U(t+\Delta t) = \sqrt{\frac{2}{\rho}} [p_a(t) - p_i(t)]^{1/2}$
$\Delta V = S \cdot U(t) \cdot \Delta t$	$\Delta V = S \cdot U(t + \Delta t) \cdot \Delta t$
$V(t) = V(t-\Delta t) + \Delta V$	$V(t+\Delta t) = V(t) + \Delta V$
$p_a(t) = -8 \cdot 10^6 V(t) + 4 \cdot 10^5$	$p_a(t+\Delta t) = -8 \cdot 10^6 V(t+\Delta t) + 4 \cdot 10^5$
$p_i(t) = p_{i0} \left(\frac{V_c}{V_c - V(t)} \right)^x$	$p_i(t+\Delta t) = p_{i0} \left(\frac{V_c}{V_c - V(t+\Delta t)} \right)^x$
$x = 1$ isothermale	$x = 1$ isothermale
$x = 1,67$ adiabatique	$x = 1,67$ adiabatique

The initial calculation conditions are the normal reactor operating conditions:

$$V(0) = 0 \text{ m/s}$$

$$\Delta V = 0 \text{ m}^3$$

$$V(0) = 0 \text{ m}^3$$

$$p_a(0) = 4 \cdot 10^5 \text{ N/m}^2$$

$$p_i(0) = 2 \cdot 10^5 \text{ N/m}^2$$

The forced flow ends when the pressure of the heavy water (p_a) and helium (p_i) are equal.

Calculations were carried out for various steps: $\Delta t = 5, 10$ and 15 ms. They all produce the same results, which are shown on tables I and II (isothermal and adiabatic compression of the helium, respectively). The latter were established with $\delta t = 5$ ms and presented with more or less extended time intervals (5, 10 15 or 20 ms) depending on the rate of variation of the phenomena.

2. FREE FLOW

Considering the two phase flow (helium against the flow of heavy water) and the difficulties of treating it by analytical means, we propose making a simple calculation that gives the orders of magnitude of the instant flow rate and the filling time. The circular entrance orifice with a diameter $D = 100$ mm is replaced by a rectangular orifice with a width of H , having the same surface S :

$$S = \frac{\pi D^2}{4} = H^2$$

$$H = \frac{D}{2} \sqrt{\pi}$$

$$H = \frac{0.1}{2} \sqrt{\pi} = 8.86 \cdot 10^{-2} \text{ m}$$

The free flow is assimilated to flow above a spillway with a height of $h = \xi \cdot H$ between the water surface and the edge of the spillway. The width considered is H . This approximation, starting from the Bernoulli equation for a perfect liquid, does not account for the reverse flow of helium in the upper part of the channel.

The average entry velocity v and the flow rate Q are given by the following equations:

$$v = \frac{2}{3} \sqrt{2gH} \sqrt{\xi} = 0,879 \sqrt{\xi} \text{ [m/s]}$$

$$Q = \frac{2}{3} \cdot \xi H^2 \sqrt{2gH} \cdot \sqrt{\xi} = 6,9 \cdot 10^{-3} \xi \sqrt{\xi} \text{ [m}^3\text{/s]}$$

with $\xi = h/H$ coefficient.

Table III gives the average velocities and the flow rates Q as a function of the ξ coefficient selected.

Table III: Speeds and Flow rates in Free Flow

ξ		1	0,9	0,8	0,7	0,6
V	m/s	0,879	0,791	0,786	0,735	0,681
Q	l/s	6,90	5,90	4,94	4,04	3,21

TABLE I: PROGRESS OF A FAST LEAK

CONSIDERING ISOTHERMAL COMPRESSION OF THE HELIUM

First Phase

TABLE II: PROGRESS OF A FAST LEAK

CONSIDERING ADIABATIC COMPRESSION OF THE HELIUM

First Phase

TABLEAU I - DEROULEMENT DE LA FUITE A GROS DEBIT

EN CONSIDERANT UNE COMPRESSION ISOTHERME DE L'HELIUM.

Première phase

Fuite à gros débit	Canal H5	RHF N° 99
$\Delta t = 5$ ms	E. BAUER J. TRIBOLET	

[ms]	0	5	10	15	20	25	30	35	40	45	50	55	60
[m/s]	0	19,1	18,7	18,4	18,1	17,7	17,4	17,0	16,7	16,4	16,0	15,7	15,3
$\sqrt{[P]}$	0	0,75	0,74	0,72	0,71	0,70	0,68	0,67	0,66	0,64	0,63	0,62	0,60
[P]	0	0,75	1,48	2,21	2,92	3,61	4,29	4,96	5,62	6,26	6,89	7,51	8,11
[bars]	4,00	3,94	3,88	3,82	3,77	3,71	3,66	3,60	3,55	3,50	3,45	3,40	3,35
[bars]	2,00	2,01	2,02	2,03	2,04	2,05	2,06	2,07	2,08	2,09	2,10	2,11	2,11
[ms]	70	80	90	100	115	130	145	165	185	205	225	245	265
[m/s]	14,7	14,0	13,3	12,6	11,5	10,5	9,4	8,0	6,6	5,2	3,7	2,2	0
$\sqrt{[P]}$	1,16	1,11	1,06	1,00	1,40	1,28	1,15	1,35	1,12	0,90	0,67	0,44	0,20
[P]	9,27	10,38	11,44	12,44	13,84	15,12	16,27	17,62	18,74	19,64	20,31	20,75	20,95
[bars]	3,26	3,17	3,09	3,01	2,89	2,79	2,70	2,59	2,50	2,43	2,38	2,34	2,32
[bars]	2,13	2,15	2,17	2,18	2,20	2,22	2,24	2,27	2,29	2,30	2,31	2,32	2,32
:													
:													

note: Read decimal points in lieu of commas. 7 = one, 7 = seven

TABLEAU II - DEROULEMENT DE LA FUITE EN CONSIDERANT UNE COMPRESSION

ADIABATIQUE DE L'HELIUM.

Première phase

Fuite à gros débit	Canal H5	RHF N° :
$\Delta t = 5$ ms	E. BAUER J. TRIBOLET	

	[ms]	0	5	10	15	20	25	30	35	40	45	50	55	60
v	[m/s]	0	19,1	18,7	18,3	18,0	17,6	17,2	16,8	16,5	16,1	15,7	15,3	14,9
V	[P]	0	0,75	0,73	0,72	0,71	0,69	0,68	0,66	0,65	0,63	0,62	0,60	0,58
v	[P]	0	0,75	1,48	2,20	2,91	3,60	4,27	4,94	5,58	6,21	6,83	7,43	8,00
pa	[bars]	4,00	3,94	3,88	3,82	3,77	3,71	3,66	3,61	3,55	3,50	3,45	3,40	3,35
pi	[bars]	2,00	2,02	2,03	2,05	2,07	2,08	2,10	2,12	2,13	2,15	2,16	2,18	2,19
	[ms]	70	80	90	100	115	130	145	165	185	205	225	235	
v	[m/s]	14,2	13,4	12,6	11,8	10,7	9,5	8,3	6,7	5,0	3,4	1,6	0	
V	[P]	1,13	1,06	1,01	0,95	1,30	1,16	1,03	1,14	0,89	0,63	0,36	0,07	
v	[P]	9,15	10,21	11,22	12,17	13,47	14,63	15,66	16,80	17,69	18,32	18,68	18,75	
pa	[bars]	3,27	3,18	3,10	3,03	2,92	2,83	2,75	2,66	2,59	2,54	2,51	2,50	
pi	[bars]	2,22	2,25	2,28	2,31	2,34	2,38	2,41	2,44	2,47	2,49	2,50	2,50	
note: Read decimal points in lieu of commas. $\gamma =$ one $\gamma =$ seven														