

A RADIATION HARD DIPOLE MAGNET COILS  
USING ALUMINUM CLAD COPPER CONDUCTORS\*

BNL--42448

DE89 014712

W.J. Leonhardt  
AGS Department, Brookhaven National Laboratory  
Associated Universities, Inc., Upton, NY 11973 USA

Abstract

A C-type septum dipole magnet is located 600 mm downstream of the primary target in an external beam line of the AGS. Conventional use of fiber glass/epoxy electrical insulation for the magnet coils results in their failure after a relatively short running period, therefore a radiation hard insulation system is required. This is accomplished by replacing the existing copper conductor with a copper conductor having a thin aluminum skin which is anodized to provide the electrical insulation. Since the copper supports a current density of 59 A/mm<sup>2</sup>, no reduction in cross sectional area can be tolerated. Design considerations, manufacturing techniques, and operating experience of a prototype dipole is presented.

Introduction

Equipment located near the fixed target stations in the AGS Experimental Areas is subjected to high levels of radiation and thus prone to damage after a short running time. One target station in particular has the coils of a C-type septum dipole magnet (10C20) located just 600 mm away from the production target itself. Currently, these coils are subjected to a radiation dose of between 10<sup>9</sup> and 10<sup>10</sup> rads/(15 week running period) and this dosage is expected to increase five fold when the AGS Booster comes on-line.[1] Since the radiation resistance of good organic insulators is less than 10<sup>9</sup> rads, a new coil design was required which provided for electrical insulation to be made from inorganic materials. The operating parameters of the existing magnet are given in Table I.

Table I

Operating Parameters of 10C20 Magnet

Maximum Field	1.2	T
Voltage	44	V
Current	3300	A
Mean Effective Length	500	mm
Water Flow	57	ℓ/min
Gap	57	mm
Rectangular Conductor	9.4	mm x 8.15 mm x
	φ5.05	mm ID

In addition to providing a "radiation hard" insulation system, the new coils for the 10C20 magnet needed to be approximately the same size as the existing coils. Equipment is packed-in rather tightly around this magnet and any significant dimensional changes to this coil would impact adjoining equipment. This essentially ruled out the use of magnesium-oxide or mineral insulated (MI) conductor since its poor packing factor (32 to 46%) would require the coil to grow significantly to provide the original number of amp-turns.[2]

Several years ago, Columbia University's Nevis Laboratories faced a similar need for radiation hard

coils and developed coils wound from aluminum conductors whose surface was hard anodized to provide electrical insulation.[3] This proved to be a successful approach and, following their use at Nevis, four quadrupoles of this design were brought to Brookhaven and have run without problems in the AGS Experimental Areas for over three years. Aluminum conductors were considered for the replacement coils, however, they were judged to be unsuitable since they could not support the 59 A/mm<sup>2</sup> current density existing in the present coils. Additionally, no metallurgical process could be found which would alter the surface of copper conductors such as anodizing does for aluminum conductors to provide the needed electrical insulation.

Alclad Approach

Since copper could handle the required current density and aluminum could have its surface made electrically non-conducting, a process was needed which would combine the two materials. The most natural approach was to use the existing copper cross-sectional dimensions and add aluminum to the outer surface of the conductor in the space traditionally allocated to fiber glass tape and epoxy resin. Since, in all probability, the aluminum thickness would be less than the epoxy-fiber glass, a slightly smaller coil could be built with the original performance capabilities.

Finding a process for applying an aluminum surface to copper proved to be a very difficult task. Aluminum will not adhere to copper in a dipping process and while copper can be plated onto aluminum, the opposite is not true. Vacuum deposition or sputtering was judged to be too labor intensive or just generally impractical. Cladding operations were then considered. Aluminum clad cable is used in the Cable T.V. business and the cable is made by sandwiching a round copper conductor between two thin sheets of aluminum and then passing it all through a set of rollers which have a circular groove in their surface. The aluminum is bonded to the copper by the extreme pressure from the rolls and excess aluminum is slit off. No vendor, however, could be found who would attempt to clad square or rectangular magnet conductor in this fashion.

Finally a process for cladding the copper conductors was identified. Copper conductors were fabricated using a conventional drawing process to produce the copper in its final rectangular cross section with a circular hole inside. When all the copper drawing was completed, it was fully annealed. A thin wall circular aluminum tube was then drawn whose inside diameter would allow the rectangular copper to be inserted into it. Alloy 1100 was chosen for the aluminum since it is a good candidate for anodizing. Next the copper was inserted the full length in the aluminum tube and the two were drawn through a rectangular die which was sized to provide a 0.25 mm aluminum skin over the copper. The aluminum-copper assembly was then heated to anneal the aluminum. The copper remained in the annealed

\*Work performed under the auspices of the U.S. Department of Energy.

DISTRIBUTION OF THIS DOCUMENT IS UNLIMITED

MASTER

DM

condition throughout the aluminum drawing process.

To minimize any work hardening of the material, it was produced, shipped, and brought to the winding process in straight lengths of 10 meters. This is sufficient to provide one complete water path for the present magnet requirements. Longer lengths can be produced, however the material would have to be wound on a spool of some sort. The cost of this material was approximately \$30 US/meter.

#### Test Magnet

Once it was shown that aluminum clad conductors could be produced, it was decided to construct a small test magnet to gain experience with winding this new material into coils, anodizing these coils, and then running the coils at the same current and field as in the full size magnet. A cross sectional view of this magnet is shown in Fig. 1. "Race-track" type coils were used rather than the actual "saddle-type" coils used in the 10C20 magnet since they were easier to wind.

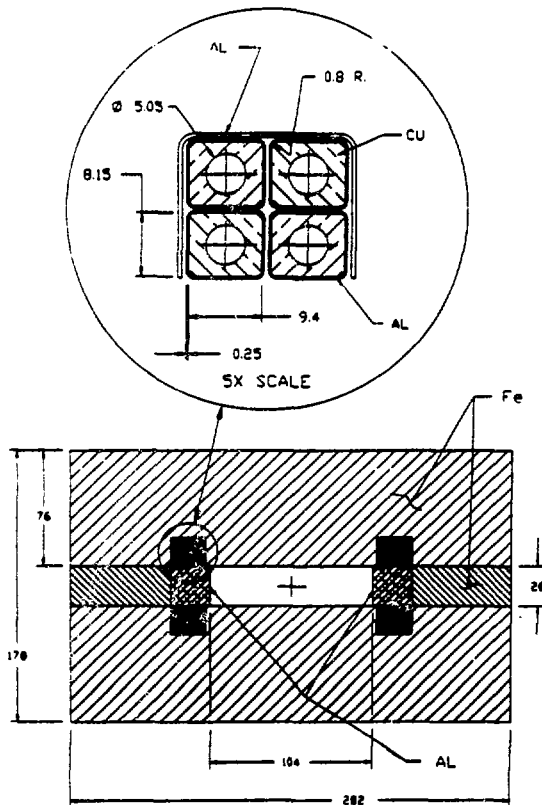

Fig. 1 Alclad Test Magnet  
(Core 356 mm long)

Since the anodized coating is brittle in nature, the coils were fully formed and then anodized. The anodizing process was similar to that used for

the Nevis coils. The steps are as follows:

1. Hand polish with "Scotch Brite".
2. Soap cleaner.
3. Water rinse.
4. Etch with Sodium Hydroxide, 37 g/l, at 49° C for one minute.
5. Water rinse.
6. Deoxidize in Nitric Acid and Ferrous Chloride at 43° C for two minutes.
7. Rinse several times with water.
8. Hard coat anodize in 20% Sulfuric Acid, 200 g/l at 2° C and 388 A/m<sup>2</sup> using a 316L stainless steel tank as the cathode.
9. Water rinse.
10. Nickel seal for 5 minutes in 0.5% solution of Nickel Acetate at close to boiling.

This process provided an anodized coating approximately 0.07 to 0.08 mm thick and cost approximately \$300 US for the two test coils.

One of the anodized test coils is shown in Fig. 2. The anodizing leaves the coils with a very dark gray color. Since any exposed copper on the coil would ruin the anodizing tanks, the anodizing vendor masks any area which copper shows or may show through. These areas are then bright aluminum in color and easy to see. Each test coil had several of these areas as shown in Figures 2 and 3. Figure 3 also shows that the cladding split at one of the bends.

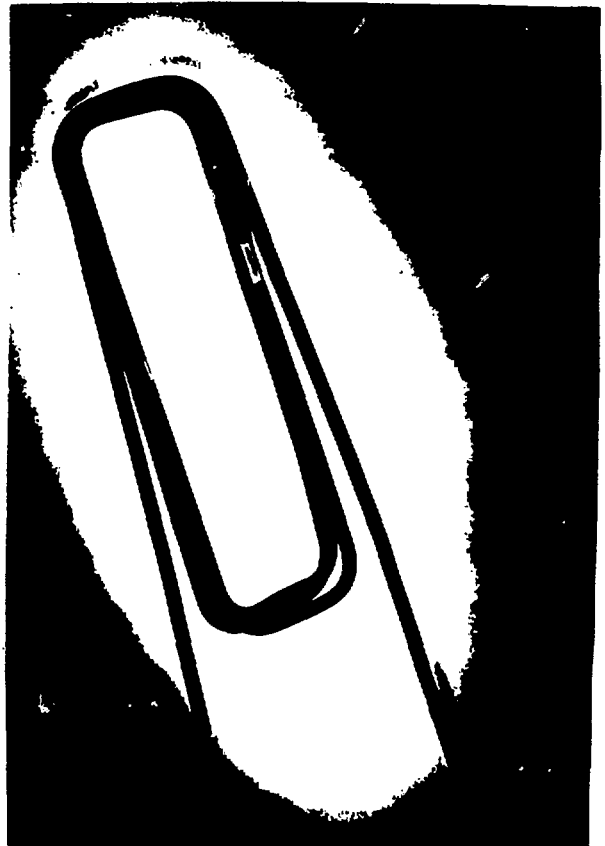

Fig. 2 Anodized coil. Bright areas have an imperfection and have not been anodized.

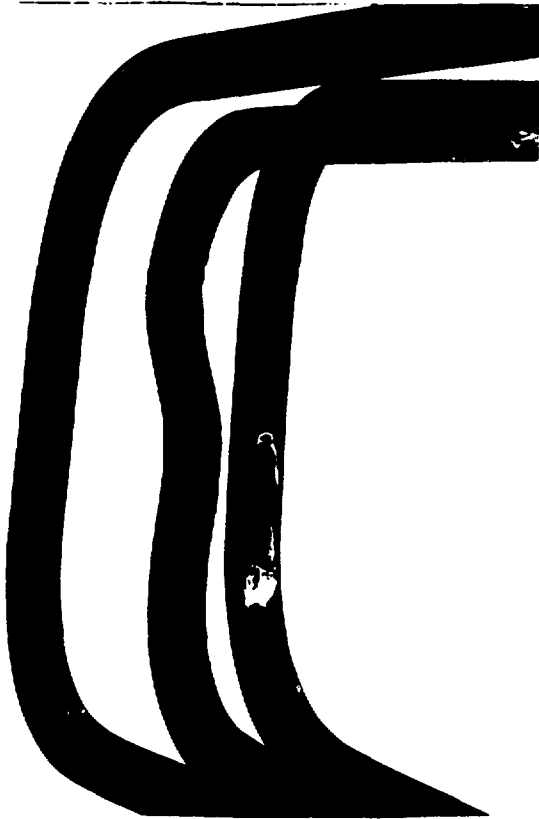

Fig. 3 Anodized coil showing split and uninsulated areas.

#### Test Results

It was decided that since none of the unanodized areas lined up with any other unanodized areas, testing could proceed and this would be a "worst case" test. The coils were tightly bound with cable ties and each impulse tested (ring test) to 600 V with no turn-to-turn shorts detected. Next the coils were inserted into the test core as shown in Fig. 4. Each coil was surrounded by an anodized aluminum channel and tested with 500 Vdc to ground with no breakdowns. Breakdown did occur at 1000 Vdc but since the 10C20 only runs at 44 Vdc, it was judged that passing the 500 Vdc test was sufficient.

The magnet was then powered up and the full 3300 A passed through the coil. To provide the full operating current, a 450 kW power supply was used which gave a pseudo DC output of 10V rms at 360 Hz. This power supply ripple causes the coils to vibrate in operation, and while this vibration was not a problem during the short-term testing, it is not known whether it will adversely affect the anodized insulation after a long running period. Water flow rates were adjusted to match the 10C20 magnet and the coils ran without a problem at 75° C. Long term testing remains to be done.

#### Summary

A process for cladding conventional copper magnet conductors with aluminum has been developed and, after forming the conductors into coils, the

aluminum has been hard anodized to provide a radiation resistant electrical insulation. Short term testing on a small dipole magnet has shown that these coils meet performance requirements. Long term testing is required to assess the effects of power supply induced vibration and corrosion in an electromagnetic radiation environment. Based on the encouraging results of the short term tests, the long term testing will be done on a full size 10C20 magnet.

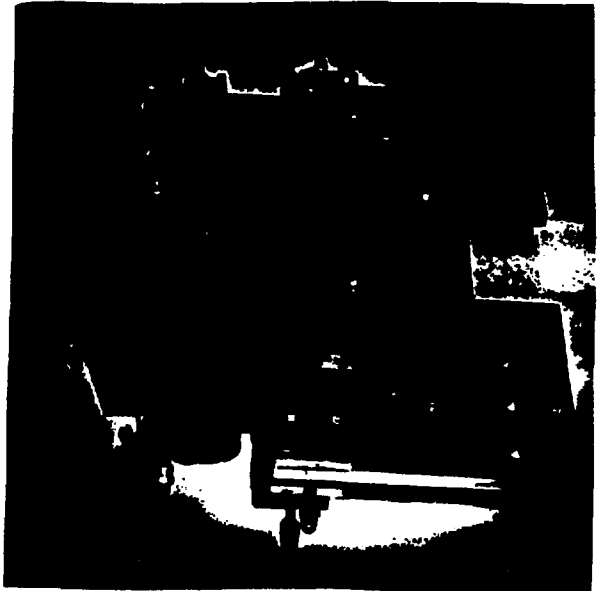

Fig. 4 Coils in test magnet.

#### Acknowledgments

The author wishes to acknowledge the valuable contributions of the following people:

Mr. Merrill Roberts of Emerson Electric Co., PA for several helpful discussions.

Mr. Tom Sarisky of Precision Tube Co., Inc., North Wales, PA for accomplishing the fabrication of the Alclad conductor.

Mr. Frank Kraft of Anacote Corp., Long Island City, NY for providing the anodizing for the coils.

The AGS's Experimental Areas Group for winding the coils, assembling, and testing the magnet.

#### References

- [1] Beavis, D., et al, "High Intensity Target Station": Phase I, Private Communication, Nov. 1988.
- [2] Catalog, Pyrotech of Canada Ltd, Trenton, Ontario, Canada.
- [3] Holland, M.M. and Joseph Shill, "Radiation Resistant Magnet Coils from Hard Anodized Aluminum Conductor," IEEE Trans Nuc Sci, Vol NS-20, No. 3, June 73, pp. 708-712.

## **DISCLAIMER**

This report was prepared as an account of work sponsored by an agency of the United States Government. Neither the United States Government nor any agency thereof, nor any of their employees, makes any warranty, express or implied, or assumes any legal liability or responsibility for the accuracy, completeness, or usefulness of any information, apparatus, product, or process disclosed, or represents that its use would not infringe privately owned rights. Reference herein to any specific commercial product, process, or service by trade name, trademark, manufacturer, or otherwise does not necessarily constitute or imply its endorsement, recommendation, or favoring by the United States Government or any agency thereof. The views and opinions of authors expressed herein do not necessarily state or reflect those of the United States Government or any agency thereof.