

CONF-890803--30  
BNL-42465

BNL--42465

DE90 001325

VACUUM CHAMBER EDDY CURRENT SELF-CORRECTION FOR THE AGS  
BOOSTER ACCELERATOR\*

G. T. DANBY and J. W. JACKSON  
Brookhaven National Laboratory, Upton, New York 11973, U.S.A.

Abstract The large sextupole and other multipoles induced by eddy currents in the vacuum chamber (VC) designed for the AGS Booster<sup>1</sup> dipoles have been cancelled by simple coils attached to the VC surface. A two turns per pole back leg winding provides the mmf required to power the correction coil by transformer action, automatically correcting even for the variable  $\dot{B}$  magnet excitation. Much larger VC positional errors of translation and rotation are acceptable because the coils follow the VC contour: the aberrations and their corrections locally have the same misplaced coordinate system. The self-correction concept could be applied to quadrupoles. However, Booster quadrupole measurements show that induced higher harmonics from VC and other eddy current sources are very small. Thus, with self-correction of the dipole VC eddy current fields,  $\dot{B}$  effects on the proton rapid cycling Booster optics are reduced to tracking of the fundamental dipole and quadrupole fields. This can be automatically controlled using field monitoring transducers located in a dipole and quadrupole operated in series with the Booster magnets.

## INTRODUCTION

For fast cycled accelerators with metallic VC, nonlinear VC eddy current fields are typically a dominant source of lattice field errors. VC are also much less mechanically accurate than stamped iron laminations so random errors generally are larger than for a carefully constructed iron magnet. High intensity proton acceleration in the AGS Booster requires rapid cycling at 7.5 Hz with  $\dot{B}=1.4$  T/sec at injection, increasing to  $\dot{B} \sim 10$  T/sec. Ordinary self supporting thick wall inconel VC are used instead of thin wall externally supported or corrugated VC. The latter are complex, costly or space consuming. They may also be less durable with the special features required of the Booster. Very high beam intensity may pro-

\* Work performed under the auspices of the U.S. Dept. of Energy.

MASTER

more corrosion. The dipole VC are curved by  $10^\circ$  and the system requires high vacuum fabrication techniques for heavy ion acceleration. Bakeout of the VC when required must be done using electrical heaters. The VC is surrounded by thermal insulation. VC location is harder to control with curvature combined with bakeout capability. The simple thick wall VC have larger systematic eddy current induced fields than thin walls. Random eddy current fields occur due to variation of geometrical and material tolerances, wall thickness and conductivity. Thin walled VC are not automatically superior for unit to unit variations.

The Booster VC eddy current induced nonlinear fields are larger than errors from other sources. Also, the VC have much larger variations and positional errors than occur for magnets and their placement. Thus, VC dominate the  $\dot{B}$  induced errors in the lattice. The self correction coils cancel the large sextupole and higher harmonics over the entire "good field" aperture. VC positional tolerances are no longer important because the cancelling fields automatically have the same displaced coordinates. This important feature cannot be achieved with pole face windings or with separate sextupole correction magnets.

Transformer action provides not only a simple passive system, but automatically adjusts for the large  $\dot{B}$  variations. VC unit to unit amplitude variations can be removed if desired. Integral measurements of the eddy current fields of individual VC can be used to slightly adjust the resistor connected in series with the VC coils and the back leg windings to remove sextupole, etc. random variations.

The fully distributed chromaticity correcting sextupoles in the Booster have sufficient strength to correct the VC eddy current sextupole in the absence of the self-correction VC windings. Apart from the other advantages of self-correction, eliminating nonlinearity at the source is optically superior. It is desirable to produce operational optical properties close to the computed lattice design. The lattice chromaticity sextupole magnets and other corrections can be used to maximize high current performance with theoretically predicted or empirically controlled linear and non-linear perturbations of operating conditions, to aid in getting the highest intensity from the Booster plus the AGS in combination.

VACUUM CHAMBER EDDY CURRENT SELF-CORRECTION FOR THE  
ACS BOOSTER ACCELERATOR

DESIGN OF THE SELF CORRECTION COILS

The VC eddy current field was computed using the POISSON code, approximating the VC geometry (Fig. 1) by 18 current elements, per quadrant. In a uniform dipole field the voltage applied to each current element per quadrant is proportional to its distance  $X$  from the center of the chamber and to  $\dot{B}$ . The area of the VC represented by the element and the VC conductivity then permit calculation of the eddy currents. With all elements excited the VC eddy currents and the resulting fields are accurately computed, including the contribution of the iron poles.

The multipole content of the single current elements was plotted as a function of angle  $\theta$ , where  $\theta = 0$  is the horizontal midplane (HMP). The two location, three turns per quadrant solution chosen produced the same nonlinear combination as the VC. Correction turns were located directly outside the VC at these angles. The simple inexpensive correction coil uses a small copper wire sheathed in ceramic inside a stainless steel tube. This is a common commercial product used, for example, in tea cup water heaters. The tube is located on the VC with a template and periodically spot welded. The engineering design will be described elsewhere.

The VC time constant  $\tau = 0.35$  millisec was computed approximately.  $\tau$  is sufficiently short that  $B$  changes adiabatically during the proton cycle. This verifies VC eddy currents are resistively determined, as assumed in the calculations. The self-correction circuit is shown inset in Fig. 1. 1A and 1B are top and bottom back leg turns. 2A and 2B are top and bottom VC turns.

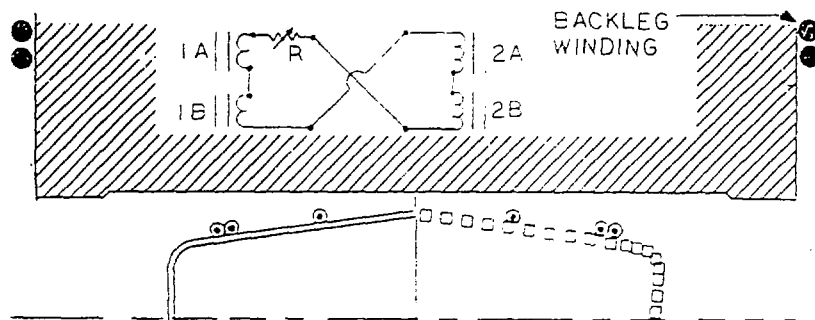

FIGURE 1 Booster vacuum chamber computer simulation and self-correction coils.

The simple VC correction coil produces localized field bumps near the 3 correction turns. Proton injection occurs at 0.16T with  $\dot{B}/B = 9 \text{ sec}^{-1}$ . Figure 2 shows the proton cycle worst case,  $\dot{B}=10 \text{ T/sec}$ ,  $(\dot{B}/B)_{\text{max}} = 32 \text{ sec}^{-1}$ . This occurs at 0.30 T (where  $\dot{B}=9.6 \text{ T/sec}$ , 6.6 times injection value). The dotted line at  $R = \pm 5.6 \text{ cm}$  corresponds to the entire VC width times phase space shrinkage. The horizontal bump injection scheme used limits considerably beam width. The actual design maximum beam width is considerably smaller. The computed eddy current induced radial field variation  $\Delta B_y/B_0$  at  $y = 0$  after self-correction is seen to be quite small. The curve at  $y = \pm 1.6 \text{ cm}$  scales to  $\pm 2.2 \text{ cm}$  at injection. The curve at  $y = \pm 2.0 \text{ cm}$ , scaling to  $\pm 2.8 \text{ cm}$  at injection would correspond to protons grazing the VC wall. Even this extreme case shows very small self-corrected residual field nonlinearity anywhere.

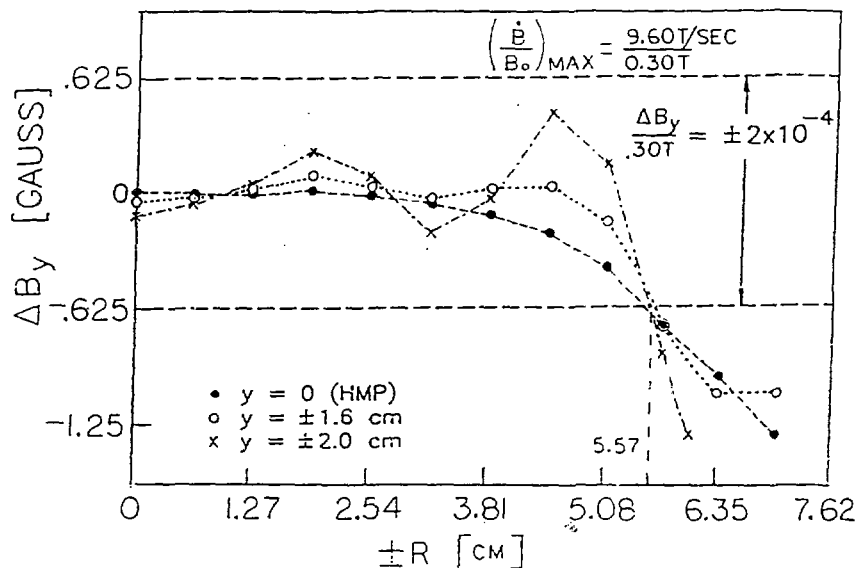

FIGURE 2 Computed self-corrected vacuum chamber field variation  $\Delta B_y$  as a function of  $R$  and  $y$  at  $\dot{B} = 10 \text{ T/sec}$ .

#### Booster Magnet VC Measurements and Discussion

An integrating search coil, curved like the trajectory, is located inside the VC. The magnet was pulsed with constant  $\dot{B}$  of 10 T/sec during rise and fall. Figure 3 shows the large radial variation in eddy current field on the HMP. (94% is due to the VC; 6% is due to magnet ends.) The point at  $R = 0$  (dipole) is arbitrary.

VACUUM CHAMBER EDDY CURRENT SELF-CORRECTION FOR THE  
 AGS BOOSTER ACCELERATOR

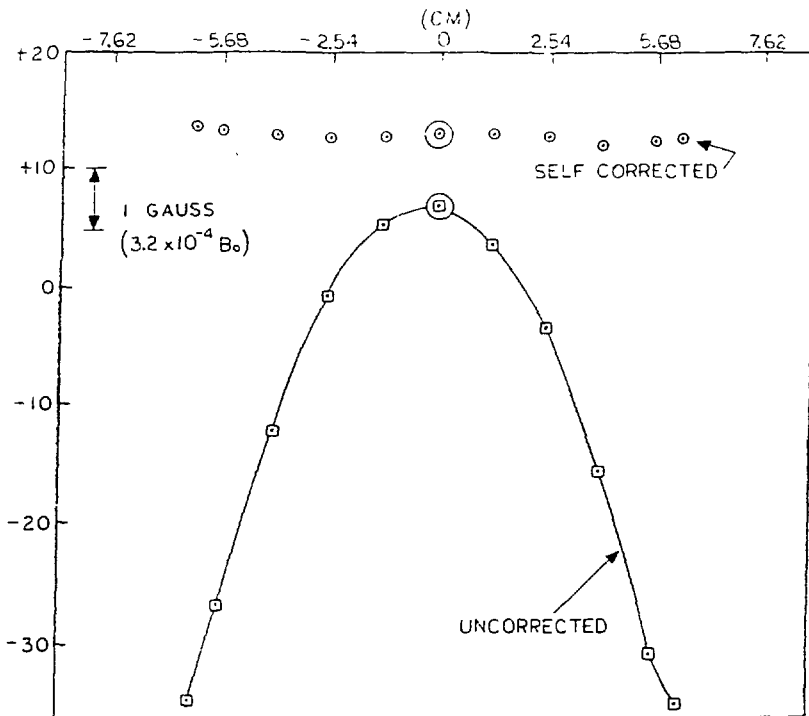

FIGURE 3 Measured booster dipole plus vacuum chamber  
 $\dot{B} = 10$  T/sec.

Initially a small power supply excited the correction coil with the primary current off. This showed that a current of 15.8 amps produced a field variation equal and opposite to that of the VC eddy currents at 10 T/sec. An adjustable resistance in series with the two turns per pole back leg windings and the self-correction coils was adjusted to give 15.8 amps. With  $\dot{B} = 10$  T/sec., the self-corrected flat curve resulted. By transformer action the integrated eddy current field is constant across the entire aperture to  $\Delta B/B_0 < 1 \times 10^{-4}$ . With no change in the series resistance 1.0 T/sec and 5.0 T/sec rise rates were measured. Figure 4 demonstrates the system will automatically adjust to any  $\dot{B}$ . The small change (dipole) shown at  $R=0$  is a rise rate dependent end effect.

The self-correction design chosen only partly cancels the dipole component of the VC. At  $\dot{B} = 10$  T/sec, the VC eddy current dipole is 30 gauss. Magnet ends contribute 2, rate independent iron magnetization 5 and the self-correction coil -7 for a total of 30 gauss. Deviation from a linear dipole transfer function is  $30/3000 = 1\%$ .

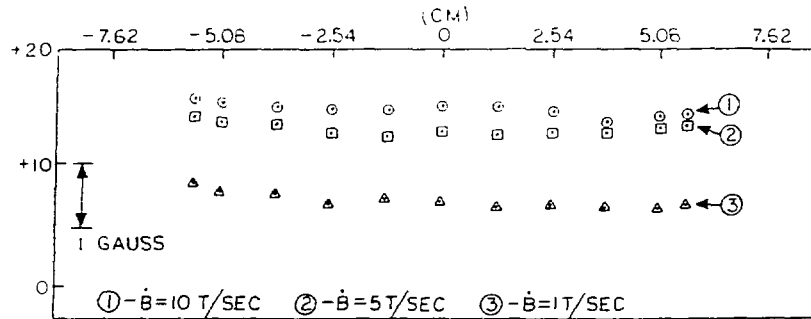

FIGURE 4 Booster dipole with corrected vacuum chamber at three rise rates.

However, the quadrupole has 0.75% deviation. The net tracking (tune) deviation is 0.25% only, to be controlled by series excited dipole and quadrupole monitors. Since 75% of the VC dipole remains after self-correction, random variations must be removed with orbit correctors. The largest quadrupole plus VC nonlinearity is  $<1 \times 10^{-4}$  (12-pole). Residual Booster VC effects are only linear.

For future machines more elaborate correctors could be used. For example, turns at  $\theta=18^\circ$  produce very pure dipole. With no bakeout cheap printed circuits could be used. Excitation with small power supplies can be added.  $\tau$  of the corrector is shorter than  $\tau$  of the VC, but could be matched, for faster cycling. For slow cycling machines self-correction could allow cheap aluminum VC.

#### ACKNOWLEDGEMENT

The authors wish to thank W. T. Weng, Y. Y. Lee and R. Damm for their support of this work and J. Koehler for his work on the design of the Booster VC correction coil.

#### REFERENCES

1. Booster Design Manual, BNL, October, 1988.
2. G. T. Danby and J. W. Jackson, Description of New Vacuum Chamber Correction Concept, contributed paper U.S. PAC, Chicago, March 20-23, 1989, BNL-41856.