

JAERI - M
90-021

COOLOD-N: A COMPUTER CODE, FOR THE ANALYSES
OF STEADY-STATE THERMAL-HYDRAULICS
IN PLATE-TYPE RESEARCH REACTORS

February 1990

Masanori KAMINAGA

JAERI-Mレポートは、日本原子力研究所が不定期に公開している研究報告書です。
入手の問い合わせは、日本原子力研究所技術情報部情報資料課（〒319-11 茨城県那珂郡東海村）
まで、お申しこしください。なお、このほか、財団法人原子力弘済会資料センター（〒319-11 茨城
県那珂郡東海村日本原子力研究所内）で複写による英費頒布をおこなっております。

JAERI-M reports are issued irregularly.

Inquiries about availability of the reports should be addressed to Information Division, Department
of Technical Information, Japan Atomic Energy Research Institute, Tokai-mura, Naka-gun,
Ibaraki-ken 319-11, Japan.

© Japan Atomic Energy Research Institute, 1990

編集兼発行 日本原子力研究所
印刷 山田軽印刷所

COOLOD-N : A Computer Code, for the Analyses
of Steady-state Thermal-hydraulics
in Plate-type Research Reactors

Masanori KAMINAGA

Department of Research Reactor Operation
Tokai Research Establishment
Japan Atomic Energy Research Institute
Tokai-mura, Naka-gun, Ibaraki-ken

(Received January 30, 1990)

The COOLOD-N code provides a capability for the analysis of the steady-state thermal-hydraulics of research reactors in which plate-type fuel is employed. This code is revised version of the COOLOD code, and is applicable not only to a forced convection cooling mode, but also to a natural convection cooling mode. In the code, a function to calculate flow rate under a natural convection, and a heat transfer package which was a subroutine program to calculate heat transfer coefficient, ONB temperature and DNB heat flux, and was especially developed for the up-graded JRR-3, have been newly added to the COOLOD code. The COOLOD-N code also has a capability of calculating the heat flux at onset of flow instability as well as DNB heat flux.

Keywords: COOLOD, COOLOD-N, DNB, Flow Instability, Forced Convection, JRR-3, Natural Convection, ONB, Plate-type Fuel, Research Reactor, Thermal-Hydraulics

板状燃料を使用する研究炉の定常熱水力解析コード
COOLOD-N

日本原子力研究所東海研究所研究炉管理部

神永 雅紀

(1990年1月30日受理)

COOLOD-Nコードは、板状燃料を使用する研究炉の定常熱水力計算が行える。本コードは、COOLODコードの改良版であり、強制対流冷却のみならず、自然循環冷却にも適用できる。主要な改良点は、自然循環冷却時の熱水力解析が可能のように、自然循環時の流量計算機能を追加したこと、JRR-3改造炉用に作成した、ONB温度、DNB熱流束等の計算機能を持つ「熱伝達パッケージ」を組込んだことである。COOLOD-Nコードは、さらに熱水力設計限界の判定に重要な、流動不安定 (Flow instability) が発生する時の熱流束計算機能も有している。

Contents

1. Introduction	1
2. Description of the COOLOD-N code	1
2.1 Fuel plate temperature calculation	1
2.2 Cooling system temperature calculation	2
2.3 ONB temperature, Flow instability, DNB heat flux and Pressure drop	2
2.4 Natural convection cooling	2
2.5 Heat transfer package	2
3. Calculation models	3
3.1 Calculation model for temperature distribution in fuel plates	3
3.2 Heat transfer calculation model (Heat transfer correlations)	5
3.3 Pressure drop calculation model	10
3.3.1 Friction loss coefficient	10
3.3.2 Pressure drop calculation model	10
3.4 Cooling tower and heat exchanger calculation model	11
3.4.1 Cooling tower temperature calculation model	11
3.4.2 Heat exchanger temperature calculation model	12
3.5 Natural convection cooling calculation model	13
4. Properties used in the code	16
4.1 Thermal conductivities of fuel meat	16
4.2 Thermal conductivities of aluminum	16
4.3 Thermal conductivities of bond layer	17
4.4 Properties of light water and heavy water	17
5. Information of input data	22
6. Concluding Remarks	37
Acknowledgements	37
References	38
Appendix A Program Structure of the COOLOD-N code	40
Appendix B Sample Calculation results	42
Appendix C Sample JCL	60

目 次

1. 序	-----	1
2. COOLOD-Nコードの概要	-----	1
2. 1 燃料板温度計算	-----	1
2. 2 冷却系温度計算	-----	2
2. 3 ONB温度、流動不安定、DNB熱流束、圧力損失	-----	2
2. 4 自然循環冷却	-----	2
2. 5 熱伝達パッケージ	-----	2
3. 計算モデル	-----	3
3. 1 燃料板温度計算モデル	-----	3
3. 2 熱伝達計算モデル(熱伝達相関式)	-----	5
3. 3 圧力損失計算モデル	-----	10
3. 3. 1 摩擦損失係数	-----	10
3. 3. 2 圧力損失計算モデル	-----	10
3. 4 冷却塔、熱交換器計算モデル	-----	11
3. 4. 1 冷却塔温度計算モデル	-----	11
3. 4. 2 熱交換器温度計算モデル	-----	12
3. 5 自然循環冷却計算モデル	-----	13
4. コードで使した物性値	-----	16
4. 1 燃料芯材の熱伝導率	-----	16
4. 2 アルミニウムの熱伝導率	-----	16
4. 3 ボンド層の熱伝導率	-----	17
4. 4 軽水及び重水の物性値	-----	17
5. 入力データについて	-----	22
6. 結 言	-----	37
謝 辞	-----	37
参考文献	-----	38
付録 A COOLOD-Nコードのプログラム構成	-----	40
付録 B 計算結果例	-----	42
付録 C JCLの例	-----	60

Nomenclature

A	: Flow area (m^2)
A_H	: Heated area (m^2)
Cp	: Specific heat (kcal/kg $^{\circ}C$)
De	: Hydraulic equivalent diameter (m)
D_H	: Heated equivalent diameter (m)
F	: Friction loss coefficient
F_b	: Bulk temperature rising factor
F_B	: Bond temperature rising factor
F_f	: Film temperature rising factor
F_u	: Fuel meat temperature rising factor
F_w	: Clad temperature rising factor
G	: Mass flow rate (kg/m 2 s)
G^*	: Dimensionless mass flow rate = $G / \sqrt{\lambda \cdot r_g \cdot g \cdot (r_L - r_g)}$
g	: Acceleration of gravity (m/s 2)
h	: Heat transfer coefficient (kcal/m 2 h $^{\circ}C$)
h_{fg}	: Latent heat of evaporation (kcal/kg)
Δh_i	: Inlet subcooled enthalpy (kcal/kg)
k	: Thermal conductivity (kcal/m h $^{\circ}C$)
L	: Flow channel length (m)
L_H	: Heated length (m)
Nu	: Nusselt number
P	: Pressure (kg/cm 2 abs.)
Pc	: Critical pressure (kg/cm 2 abs.)
Pe	: Peclet number
P_H	: Heated perimeter (m)
Pr	: Prandtl number
q	: Heat flux (kcal/m 2 h)
q^*	: Dimensionless heat flux = $q / \{h_{fg} \sqrt{\lambda \cdot r_g \cdot g \cdot (r_L - r_g)} \cdot 3600\}$
Q	: Heat generation rate (kcal/h)
Re	: Reynolds number
T	: Temperature ($^{\circ}C$)
v	: Velocity (m/s)
W	: Width of channel (m)
x	: Quality
y	: Thickness (m)

- Z : Distance from inlet of channel (m)
 β : Volumetric expansion coefficient (1/°C)
 ε : Surface roughness (m)
 λ : Characteristic length = $\sqrt{\sigma/(\gamma_L - \gamma_g)}$ (m)
 μ : Dynamic viscosity (kg/m s)
 ν : Kinematic viscosity (m²/s)
 γ : Specific weight (kg/m³)
 ζ : Resistance coefficient due to geometry change
 η : Bubble detachment parameter

Subscript

- b** : Bulk
B : Bond
DNB: Departure from Nucleate Boiling
f : Film
g : Steam
l : Liquid
in : Inlet
ONB: Onset of Nucleate Boiling
s : Saturated
sub: Subcooled
U : Fuel meat
W : Clad or wall

1. Introduction

In Japan Atomic Energy Research Institute (JAERI), COOLOD code was developed for thermohydraulic analysis of research reactors in which plate type fuel is employed^[1]. Thermohydraulic analyses of the JRR-2, the upgraded JRR-3^[2], JRR-4^[3] and so on have been performed, using the COOLOD code. COOLOD-N code is a revised version of the COOLOD code. In the COOLOD-N code, a function to calculate flow rate under a natural convection cooling mode, and a heat transfer package which was especially developed for the upgraded JRR-3 based on the heat transfer experiments have been newly added to the COOLOD code.^[4] The COOLOD-N code also has a capability of calculating the heat flux at onset of flow instability as well as DNB heat flux.

2. Description of the COOLOD-N code

2.1 Fuel plate temperature calculation

Fuel plate temperatures are calculated by assuming that the heat generation in fuel meat is constant along the radial direction and considering one dimensional heat conduction. An axial fuel plate temperature distribution is calculated from local bulk temperatures of the coolant and axial peaking factors. In case of some kinds of fuel plates which have different heat generation rate one another, exist in a fuel element, or right-hand side and left-hand side of the fuel plate cooling conditions are different due to different configuration of coolant channels or different coolant velocities, the code can calculate temperature distribution of each fuel plate. In case of some kinds of fuel elements exist in a core, the code is also able to calculate temperature distribution of each fuel element by using power distribution factors etc..

Given the fuel meat material (choice U-Al-alloy, $U-Al_x-Al$) and the uranium density, the code calculates thermal conductivities of the fuel meat. Thermal conductivities of the fuel meat can be also inputted by data table. The properties of light water, heavy water and aluminum alloy are already given in the code.

2.2 Cooling system temperature calculation

In addition to the fuel plate temperature calculation, Coolant temperatures of the primary and the secondary cooling system can be calculated by the COOLOD-N code. In this calculation, heat loss from the surface of piping, heat exchanger and so on are neglected.

Counter flow type cooling tower, and counter flow type, parallel flow type and shell & tube type heat exchangers are treated in the code.

2.3 ONB temperature, Flow instability, DNB heat flux and Pressure drop

The code has capabilities of calculating the ONB temperature, heat flux at onset of flow instability and DNB heat flux which are important to confirm safety of the reactor. The code also has a capability of calculating pressure drops and local pressures in the core which are required to calculate above value. As flow direction in the core, downward flow, upward flow and horizontal flow are treated in the code.

2.4 Natural convection cooling

In general, pool type research reactors have a natural convection cooling mode as well as a forced convection cooling mode. In the natural convection cooling mode, the core flow is an upward flow, which is supplied by the downflow through a natural circulation valve, through a core by-pass and so on. The driving force for the natural circulation is calculated by the difference between the outlet water density of the core flow heated by core power and the inlet water density through a core by-pass or through a natural circulation valve.

2.5 Heat transfer package

"Heat transfer package" is a sub-program for calculating heat transfer coefficient, ONB temperature, heat flux at onset of flow instability and DNB heat flux. The "Heat transfer package" was especially developed for research reactors which are operated under low pressure and low temperature conditions using plate-type fuel, just like as the upgraded JRR-3.^[5] Heat transfer correlations adopted in the "Heat transfer package" were obtained or

estimated based on the heat transfer experiments in which thermohydraulic features of the upgraded JRR-3 core were properly reflected. The "Heat transfer package" is applicable to, not only upward flow, but also downward flow.

3. Calculation models

3.1 Calculation model for temperature distribution in fuel plates

Assuming that the heat generation in fuel meat is constant along the radial (thickness) direction ($Q = q/y_U = \text{constant}$), and considering one dimensional heat conduction, temperature distribution in fuel plates are calculated as follows. Figure 1 shows calculation model of temperature distribution in fuel plates.

(1) Coolant bulk temperature : T_b

$$T_b = T_{in} + F_b \frac{1}{G A C_p * 3600} \int_0^L Q(Z) dZ \quad (3.1.1)$$

(2) Clad outer surface temperature : T_W

$$T_W = T_b + F_f q/h \quad (3.1.2)$$

(3) Clad inner surface temperature : T_{WB}

$$T_{WB} = T_W + F_W q y_W/k_W \quad (3.1.3)$$

(4) Fuel meat surface temperature : T_{BU}

$$T_{BU} = T_{WB} + F_B q y_B/k_B \quad (3.1.4)$$

(5) Fuel meat maximum temperature : T_{Uo}

$$T_{Uo} = T_{BU} + F_U \{(q/y_U)/2k_U\} y_U^2 \quad (3.1.5)$$

If the cooling condition of right hand side and left hand side of the fuel plate are different, then the COOLOD-N code calculates a fuel meat maximum temperature until the fuel meat maximum temperature of right hand

side and left hand side are equal by changing the location of maximum temperature point. If the cooling conditions of right hand side and left hand side of the fuel plate are equal, then the fuel maximum temperature appears center of the fuel meat.

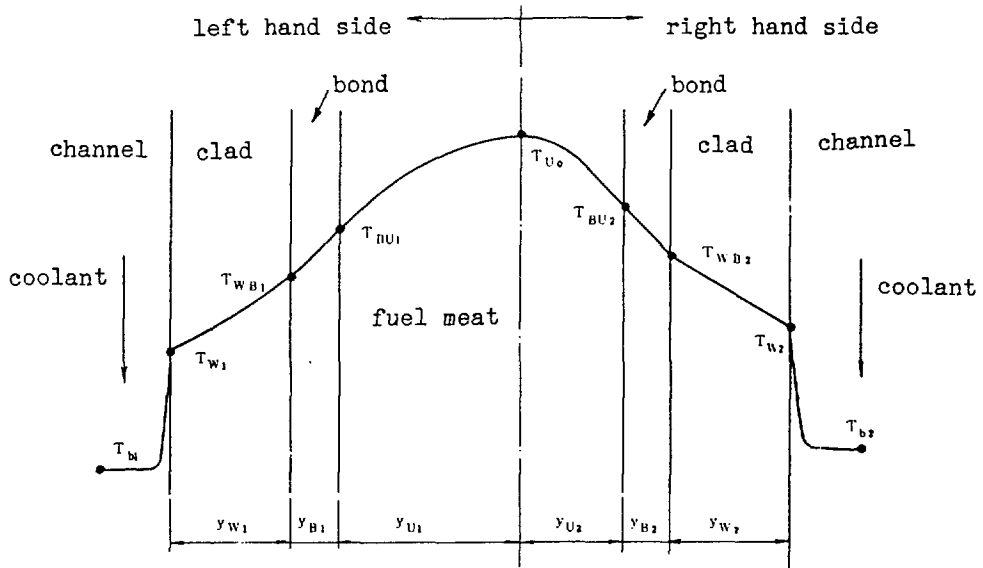

Fig. 1 Fuel Plate Temperature Calculation Model

3.2 Heat transfer calculation model (Heat transfer correlations)

In the COOLOD-N code, we can select not only the COOLOD code original heat transfer correlations, but also the "Heat transfer package" which was developed for thermohydraulic analysis of research nuclear reactors in which plate-type fuel is employed. Table 1 shows the COOLOD code original heat transfer correlations. We can select each of heat transfer correlations by input data.

The "Heat transfer package" used in the COOLOD-N code is shown as follows

(1) Single-phase forced-convection flow

Downward flow ($G < 0$)

$$Nu \equiv \frac{h \cdot D_e}{k} = 4.0 \quad \text{for laminar flow (Re < 2000)} \quad (3.2.1)$$

$$Nu = 0.023 Re_b^{0.8} Pr_b^{0.4} \quad \text{for turbulent flow (Re} \geq 2500) \quad (3.2.2)$$

(Dittus-Boelter correlation^[6])

Nusselt number is evaluated by interpolation with Eq.(3.2.1) and (3.2.2) for transition region ($2000 \leq Re < 2500$).

Figure 2 shows scheme of single-phase forced-convection heat transfer for Downward flow.

Upward flow ($G > 0$)

$$Nu = \max[\text{Eq.(3.2.1), Collier correlation}] \text{ for laminar flow (3.2.3)}$$

(Re < 2000)

where Collier correlation^[7] is given as follows.

$$Nu = 0.17 Re_f^{0.33} Pr_f^{0.43} \left\{ \frac{(Pr_f)_f}{(Pr_f)_w} \right\}^{0.25} \left\{ \frac{g \beta D_e^3 (T_w - T_l)}{\nu^2} \right\}_f^{0.1} \quad (3.2.4)$$

Nusselt number is evaluated by Eq.(3.2.2) for turbulent flow region (Re \geq 2500).

Nusselt number is evaluated by interpolation with Eq.(3.2.4) and (3.2.2) for transition region ($2000 \leq Re < 2500$).

A scheme of the single-phase forced-convection heat transfer for Upward flow is shown in Fig.3.

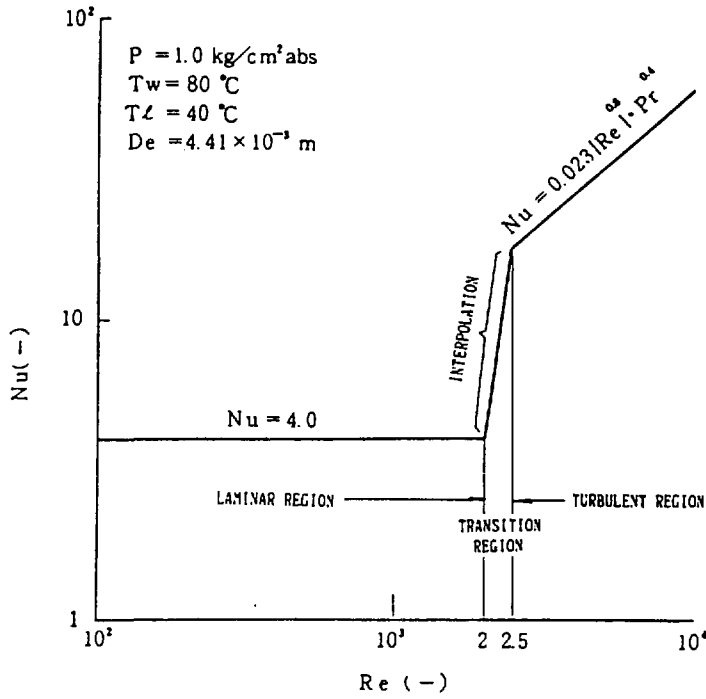

Fig. 2 Single Phase Liquid Forced Convection Heat Transfer for Down Flow

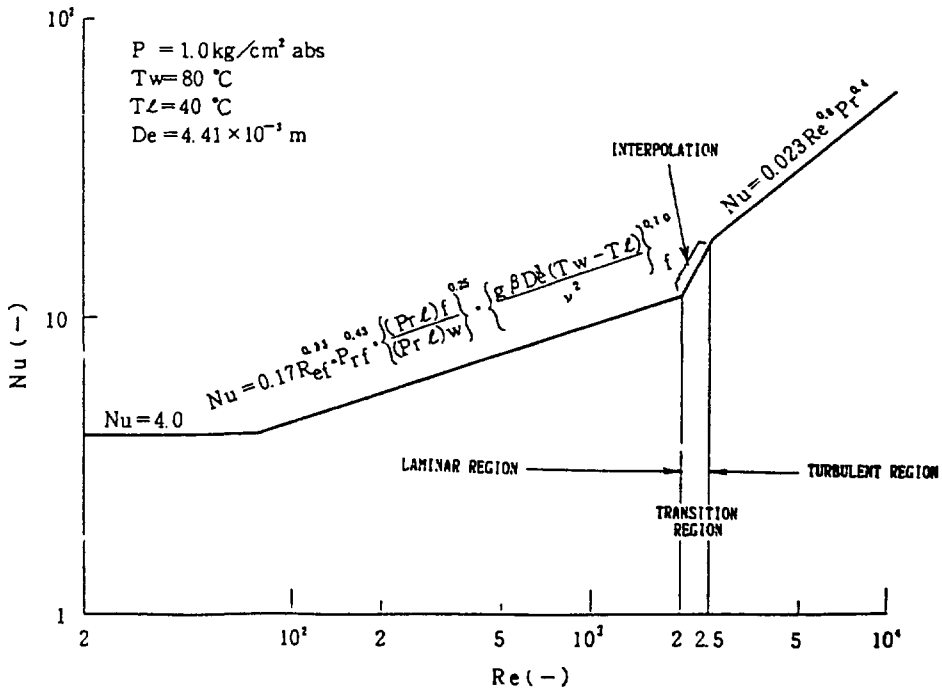

Fig. 3 Single Phase Liquid Forced Convection Heat Transfer for Up Flow

(2) Nucleate boiling heat transfer

ONB Temperature (Bergles-Rohsenow correlation^[8])

$$q = 911 P^{1.156} \left\{ \frac{g}{5} (T_{ONB} - T_S) \right\} P^{\frac{2.16}{0.0234}} \quad (3.2.5)$$

A scheme of ONB temperature for Downward flow is shown in Fig.4 (example).

Subcooled nucleate boiling (Modified Chen correlation^{[7],[9]})

$$q = 0.023 Re_b^{0.8} Pr_b^{0.4} \frac{k}{De} (T_w - T_l) + S \cdot 7.228 \frac{k_f^{0.79} C_{p_f}^{0.45} \gamma_f^{0.49} (T_w - T_S)^{1.24} (P_w - P)^{0.75}}{\sigma^{0.5} \mu_f^{0.29} h_{fg}^{0.24} \gamma_g^{0.24}} \quad (3.2.6)$$

where

$$Re' \equiv \frac{G \cdot De}{\mu_f g} \times 10^{-4}$$

$$\frac{1}{1 + 0.12 Re'^{1.14}} \quad Re' < 32.5$$

$$S = \frac{1}{1 + 0.4 Re'^{0.78}} \quad 32.5 \leq Re' < 70.0$$

$$0.1 \quad 70.0 \leq Re'$$

Saturated nucleate boiling (Chen correlation^{[7],[9]})

$$q = F \cdot 0.023 \{ Re_f (1-x) \}^{0.8} Pr_f^{0.4} \frac{k_f}{De} (T_w - T_S) + S \cdot 7.228 \frac{k_f^{0.79} C_{p_f}^{0.45} \gamma_f^{0.49} (T_w - T_S)^{1.24} (P_w - P)^{0.75}}{\sigma^{0.5} \mu_f^{0.29} h_{fg}^{0.24} \gamma_g^{0.24}} \quad (3.2.7)$$

where

$$\frac{1}{x_{tt}} \equiv \left(\frac{1}{1-x} \right)^{0.9} \left(\frac{\gamma_f}{\gamma_g} \right)^{0.5} \left(\frac{\mu_g}{\mu_f} \right)^{0.1}$$

$$F = \begin{cases} 1.0 & \frac{1}{x_{tt}} \leq 0.1 \\ 2.35 \left(\frac{1}{x_{tt}} + 0.213 \right)^{0.736} & \frac{1}{x_{tt}} > 0.1 \end{cases}$$

$$Re' \equiv \frac{G (1-x) De}{\mu_f g} \times 10^{-4}$$

$$\frac{1}{1 + 0.12 Re'^{1.14}} \quad Re' < 32.5$$

$$S = \frac{1}{1 + 0.42 Re'^{0.78}} \quad 32.5 \leq Re' < 70.0$$

$$0.1 \quad 70.0 \leq Re'$$

A scheme of Chen correlation is shown in Fig.5.

(3) DNB heat flux^{[10],[11]}

$$q_{DNB,1}^* = 0.005 |G^*|^{0.611} \quad (3.2.8)$$

$$q_{DNB,2}^* = \frac{A}{A_H} \frac{\Delta h_i}{h_{fg}} |G^*| \quad (3.2.9)$$

$$q_{DNB,3}^* = 0.7 \left(\frac{A}{A_H} \right) \left\{ W \left(\frac{\gamma_l}{\sigma} \right)^{1/2} \right\}^{1/2} \left\{ 1 + \left(\frac{\gamma_g}{\gamma_l} \right)^{1/4} \right\}^2 \quad (3.2.10)$$

Downward flow ($G < 0$)

DNB heat flux is evaluated by

$$\min[\text{Eq. (3.2.8)}, \max[\text{Eq. (3.2.9)}, \text{Eq. (3.2.10)}]]$$

Upward flow ($G \geq 0$)

DNB heat flux is evaluated by

$$\max[\text{Eq. (3.2.8)}, \text{Eq. (3.2.10)}]$$

A scheme of DNB heat flux correlations is shown in Fig.6.

(4) Heat flux at Onset of Flow Instability

The criterion for the onset of flow instability (flow excursion or Ledinegg instability) has been obtained for rectangular channels by Whittle and Forgan^[12].

$$\frac{T_{out} - T_{in}}{T_s - T_{in}} = \frac{1}{1 + \eta \frac{D_H}{L_H}} \quad (3.2.11)$$

Energy balance is given by

$$q A_H = Cp(T_{out} - T_{in}) G * 3600 \quad (3.2.12)$$

From Eq.(3.2.11) and (3.2.12), a following correlation was obtained.

$$q = \frac{1}{A_H} \cdot \frac{Cp(T_s - T_{in}) * 3600}{1 + \eta \frac{D_H}{L_H}} \cdot G = \frac{Cp \Delta T_{sub} * 3600}{A_H + 4 \eta A} \cdot G \quad (3.3.13)$$

The bubble detachment parameter η was determined empirically to be 25^[12]

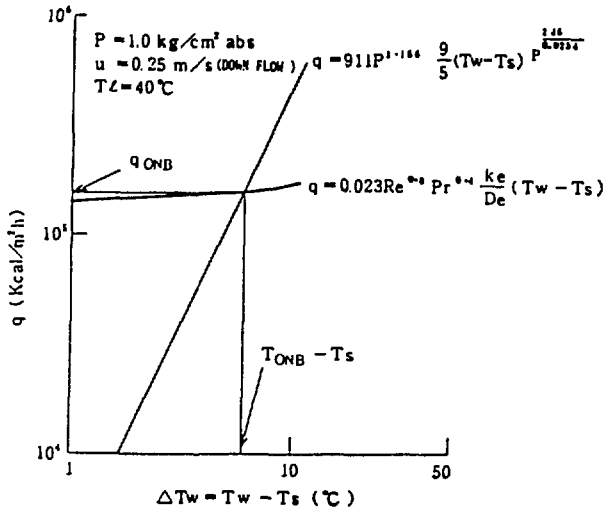

Fig. 4 Ex. of ONB Down Flow

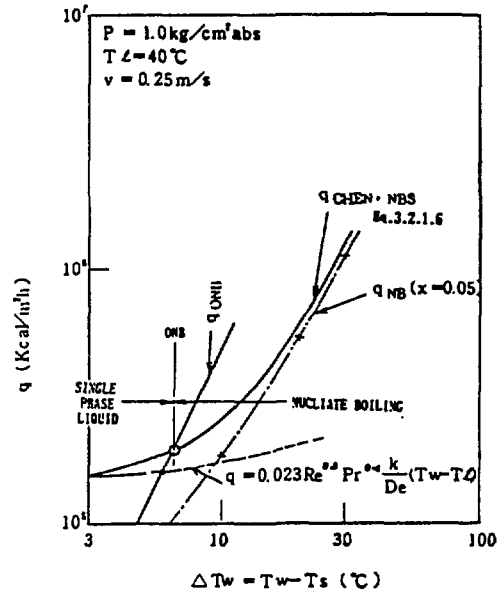

Fig. 5 Nucliate Boiling Chien Correlation

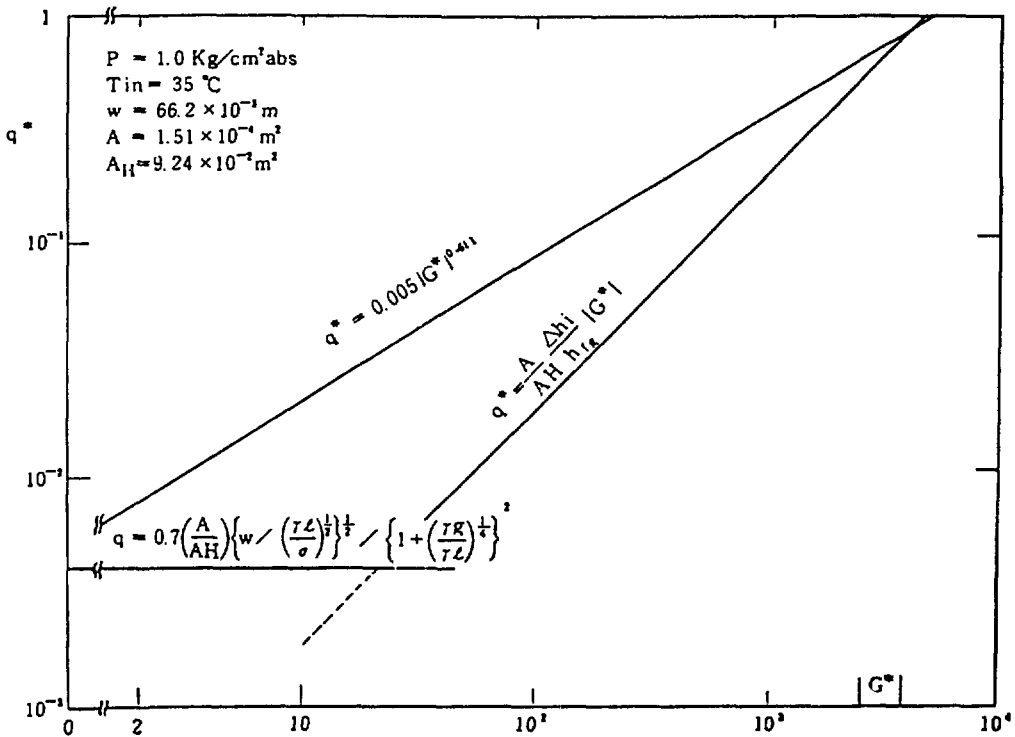

Fig. 6 DNB Heat Flux Correlations

3.3 Pressure drop calculation model

3.3.1 Friction loss coefficient^[13]

(1) Friction loss coefficient for laminar flow ($Re \leq 2500$)

$$F = \frac{C_b}{Re} \quad (3.3.1)$$

where C_b is a factor which depends on the configuration of the channel.

$C_b = 64.0$	for tube
$C_b = 56.9$	for square
$C_b = 96.0$	for rectangular

(2) Friction loss coefficient for turbulent flow ($Re > 2500$)

We can select following correlation.

Blasius correlation

$$F = 0.3164 \cdot Re^{-0.25} \quad (3.3.2)$$

Karman-Nikuradse correlation

$$\frac{1}{\sqrt{F}} = 2.0 \log_{10} (Re \cdot \sqrt{F}) - 0.8 \quad (3.3.3)$$

Cole-Brook correlation

$$\frac{1}{\sqrt{F}} = -2.0 \log_{10} \left[\frac{\epsilon/De}{3.71} + \frac{2.51}{Re \sqrt{F}} \right] \quad (3.3.4)$$

3.3.2 Pressure drop calculation model

A pressure drop calculation model for the COOLOD-N code is shown in Fig.7. In this calculation model, a pressure drop due to friction loss is calculated as a pressure drop inside the segment. A pressure drop due to geometry change is calculated as a pressure drop between segment n and segment $n+1$. A local pressure $P_{n,1}$ and $P_{n,2}$ of n -th segment is calculated as follows by using Bernoulli's theorem.

$$P_{n,1} = P_{n-1,2} + \frac{1}{2g} (\tilde{\gamma}_{n-1} \cdot v_{n-1}^2 - \tilde{\gamma}_n \cdot v_n^2 \cdot r_n \cdot \zeta_n \cdot \tilde{v}_{n+1}^2) \quad (3.3.5)$$

$$P_{n,2} = P_{n,1} + \tilde{\gamma}_n (L \cdot \Delta Z_n - F_n \cdot \frac{\Delta \tilde{\gamma}_n}{\tilde{\gamma}_n} \cdot \frac{\tilde{v}_n^2}{2g}) \quad (3.3.6)$$

where

$$\tilde{\gamma}_n = \frac{r_n + r_{n+1}}{2} \quad : \text{Average specific weight of the segment } n$$

$$L \quad : \text{Flow direction factor} = -1 : \text{Upward flow}$$

$$= 0 : \text{Horizontal flow}$$

$$= 1 : \text{Downward flow}$$

$$\tilde{v}_n = \text{Max} (v_n, v_{n+1})$$

and $P_{0,2} = P_{in}$ is given by input data. In the non-heated channel, $r_n = r_{n+1} = \tilde{\gamma}_n$.

3.4 Cooling tower and heat exchanger calculation model

3.4.1 Cooling tower temperature calculation model^[14]

In case of considering a heat exchange between air and water at the cooling tower, transfer unit U of the cooling tower is expressed as follows.

$$U = \frac{K_a}{G} \cdot V \quad (3.4.1)$$

where

K_a : Overall volumetric heat transfer coefficient based on enthalpy difference ($\text{kcal}/\text{m}^3 \text{h} \Delta h$)

G : Air flow rate (kg'/h)^{*}

V : Volume of the cooling tower (m^3)

Transfer unit U is also expressed as follows.

$$U' = N \int_{i_n}^{\text{out}} \frac{-dT_b}{h_b - h} \quad (3.4.2)$$

where

N : Water air ratio

h : Enthalpy of air (kcal/kg')^{*}

h_b : Enthalpy of saturated air at water temperature T_b

T_b : Temperature at the cooling tower ($^{\circ}\text{C}$)

* kg' means weight of dry air in the wet air

Inlet and outlet temperatures of the cooling tower are calculated from Eq. (3.4.1) and Eq. (3.4.2) by using a wet-bulb temperature, a water-air ratio N and dummy inlet and outlet temperature of the cooling tower T_{bin}' , T_{bout}' .

3.4.2 Heat exchanger temperature calculation model^[15]

Inlet and outlet temperatures of the primary coolant in a heat exchanger are calculated from the temperature T_1' of the secondary coolant.

$$T_{in} = T_1' + \frac{\Delta T}{E_A} \quad (3.4.3)$$

$$T_{out} = T_{in} - \Delta T \quad (3.4.4)$$

where

T : Temperature difference between inlet and outlet temperature of primary coolant ($^{\circ}\text{C}$)

T_{in} : Inlet temperature of primary coolant ($^{\circ}\text{C}$)

T_{out} : Outlet temperature of primary coolant ($^{\circ}\text{C}$)

E_A : Exchanger effectiveness

If a heat exchanger type is different, then E_A has also different value. E_A is calculated as follows.

(1) Counterflow type heat exchanger

$$E_A = \frac{1 - \exp(-(NTU)_A \cdot (1 - R_A))}{1 - R_A \exp(-(NTU)_A \cdot (1 - R_A))} \quad (3.4.5)$$

(2) Parallelfow type heat exchanger

$$E_A = \frac{1 - \exp(-(NTU)_A \cdot (1 + R_A))}{1 + R_A} \quad (3.4.6)$$

(3) Shell and tube type heat exchanger (Shell side m pass, tube side $2m$ pass)

1) $m = 1$

$$E_A = \frac{2}{(1 + R_A) + \sqrt{1 + R_A^2} \cdot \frac{1 + \exp(-F)}{1 - \exp(-F)}} \quad (3.4.7)$$

where

$$r = (NTU)_A \sqrt{1 + R_A}$$

1) $m > 2$

$$E_A = \frac{\left(\frac{1 - E_s \cdot R_A}{1 - E_s}\right)^m - 1}{\left(\frac{1 - E_s \cdot R_A}{1 - E_s}\right)^m - R_A} \quad (3.4.8)$$

where

R_A : Capacity rate ratio of primary coolant and secondary

$$\text{coolant} = \frac{W_1}{W_2}$$

$(NTU)_A$: Number of transfer unit = $\frac{U A_H}{W}$

U : Overall heat transfer coefficient (kcal/m²h°C)

W : Heat capacity = $G A C_p$ (kcal/h C)

A_H : Heat transfer area of the heat exchanger (m²)

3.5 Natural convection cooling calculation model

In the natural convection cooling model, m kind of heated channels and n kind of core bypass channels (non-heated channel) are considered in the COOLOD-N code. A basic equation used in this calculation model is a equation of conservation of mass between heated channels and non-heated channels.

A sum of mass flow rates G_j for core bypass channels is equal to a sum of mass flow rates G_i for heated channels.

$$\sum_{i=1} G_i = \sum_{j=1} G_j = G_0 \quad (3.5.1)$$

On the other hand, the relation between a pressure drop of the heated channel in the core ΔP_{ci} ($i=1$ to i_{max}), a pressure drop of the non-heated channel (core bypass) ΔP_{bj} ($j=1$ to j_{max}), and a driving force ΔP_{di} ($i=1$ to i_{max}) are expressed below.

$$\Delta P_{ci}(G_i) + \Delta P_{bi}(G_i) = \Delta P_{di}(G_i) \quad (3.5.2)$$

$$\Delta P_{bj} (G_j) = \Delta P_b \text{ (Constant)} \quad (3.5.3)$$

The driving force ΔP_{di} for the natural circulation is expressed with the difference between the water density ρ_i' of heated channel and the water density ρ through non-heated channel (core bypass), and is shown below.

$$\begin{aligned} \Delta P_{di} &= \int_0^{L_i} (\rho - \rho_i') \cdot dx \\ &= \sum_{m=1}^{m_{\max}} (\rho \cdot \ell_{im} - \rho_i' \cdot \ell_{im}) \\ &= \rho \cdot L_i - \sum_{m=1}^{m_{\max}} \rho_i' \cdot \ell_{im} \end{aligned} \quad (3.5.4)$$

where

$$\begin{aligned} L_i &: \text{Heated length of } i\text{-th channel (m)} = \sum_{m=1}^{m_{\max}} \ell_{im} \\ \ell_{im} &: \text{Heated length of } m\text{-th segment of } i\text{-th channel (m)} \end{aligned}$$

The driving force is calculated by the coolant temperature distribution of the heated channel which depends on the core power.

If nucleate boiling would occur in the core, the right hand side of Eq. (3.5.4) will be replaced by following equation.

$$\rho_i' \cdot \ell_{im} = (1 - \alpha_{im}) \cdot \rho_{\ell_{im}} \cdot \ell_{im} \quad (3.5.5)$$

where

$\rho_{\ell_{im}}$: Saturated water density of m -th segment of i -th heated channel (kg/m^3)

α_{im} : Void fraction of m -th segment of i -th heated channel

In this calculation model, the condition of onset of nucleate boiling is defined as follows^[16].

$$\text{Nu}_b = \frac{q \cdot De}{K_b \cdot (T_s - T_b)} \geq 455 \quad ; \quad \text{Pe} \leq 7000 \quad (3.5.6)$$

$$\text{St}_b = \frac{q}{G \cdot C_{pb} \cdot (T_s - T_b)} \geq 0.0065 \quad ; \quad \text{Pe} > 7000 \quad (3.5.7)$$

The void fraction is calculated by following correlation.

- (1) Void fraction under subcooled boiling region (AHMAD correlation)^[17]

$$\alpha = \frac{x}{x + s(1-x) \gamma_g / \gamma_l} \quad (3.5.8)$$

$$s = \left(\frac{\gamma_l}{\gamma_g}\right)^{0.205} \cdot \left(\frac{G \cdot D}{\mu_l}\right)^{-0.016} \quad (3.5.9)$$

- (2) Void fraction under subcooled boiling region (Zuber correlation)^[18]

$$\alpha = \frac{x}{1.13 \left(x \frac{\gamma_l - \gamma_g}{\gamma_l} + \frac{\gamma_g}{\gamma_l} \right) + C_b \frac{\gamma_g}{G} \left[\frac{\sigma(\gamma_l - \gamma_g) \cdot g}{\gamma_l^2} \right]^{1/4}} \quad (3.5.10)$$

- (3) Void fraction under subcooled boiling region (Combination of Eq.(3.5.9) and Eq.(3.5.10))

$$G < G_{LIM} \quad \text{then Eq. (3.5.9)}$$

$$G \geq G_{LIM} \quad \text{then Eq. (3.5.10)}$$

where, G_{LIM} (kg/s) is given by input data. The range of G_{LIM} is 500 1500 (kg/m²s).

- (4) Void fraction under nucleate boiling region (Zuber correlation)^[19]

$$\alpha = \frac{x}{1.13 \left(x_{eq} \cdot \frac{\gamma_l - \gamma_g}{\gamma_l} + \frac{g}{\ell} \right) + C_b \cdot \frac{\gamma_g}{G} \cdot \left[\frac{\sigma \cdot (\gamma_l - \gamma_g) \cdot g}{\gamma_l^2} \right]^{1/4}} \quad (3.5.11)$$

In the (1) (4)

$$x = \frac{x_{eq} - x_{eqB} \cdot e^{x_{eq}/x_{eqB} - 1}}{1 - x_{eqB} \cdot e^{x_{eq}/x_{eqB} - 1}} \quad (3.5.12)$$

$$x_{eq} = \frac{q_w \cdot P_h \cdot Z / (G \cdot A) - C_{pb} (T_s - T_{bb})}{h_{fg}}$$

x_{eqB} : Quality at the point of onset of nucleate boiling

T_{bb} : Coolant temperature at the point of onset of nucleate boiling (°C)

Z : Distance from the point of onset of nucleate boiling (m)
 P_h : Heated perimeter (m)
 C_b : Zuber's constant = 1.18 or 1.41

4. Properties used in the code

4.1 Thermal conductivities of fuel meat

Given the fuel meat material (choice U-Al-alloy, U-Al_x-Al) and the uranium density, the thermal conductivity of the fuel meat is calculated by the code. Thermal conductivities used in the code are shown below.

(1) Thermal conductivity of U-Al alloy^[20]: k_{u0}

k_{u0} : $0.415 - 1.0 \times 10^{-4} T_u$; ($20 < T_u < 640^\circ\text{C}$)
 k_{u0} : 0.135 ; ($T_u > 640^\circ\text{C}$)
 K_{u0} : Thermal conductivity of U-Al alloy (cal/s·cm°C)
 T_u : Temperature of U-Al alloy (C)

(2) Thermal conductivity of U-Al_x dispersion fuel^[21]: k_{u1}

k'_{u1} : $2.16546 - 2.765 x$
 k_{u1} : Thermal conductivity of U-Al_x dispersion fuel (W/cm°C)
 x : Weight fraction of uranium in the fuel meat

$$= \frac{\rho}{0.8 \rho + 2.7(1-P)}$$
 ρ : Uranium density of U-Al_x dispersion fuel
 P : Porosity
 $k_{u1} = k'_{u1} (1-P)^{3/2}$

Thermal conductivities of the fuel meat can be also inputted by data table.

4.2 Thermal conductivities of aluminum^[22]: k_{Al}

k_{Al} : $0.390 + 2.22 \times 10^{-4} T_{Al} - 3.79 \times 10^{-7} T_{Al}^2 + 2.42 \times 10^{-10} T_{Al}^3$
; ($20 < T_{Al} < 649^\circ\text{C}$)
 k_{Al} : 0.170 ; ($T_{Al} > 649^\circ\text{C}$)
 T_{Al} : Temperature of aluminum clad (°C)

4.3 Thermal conductivities of bond layer^[23]: k_B

$$k_B = 0.123804 \times 10^{-4} - 0.593896 \times 10^{-7} T_B - 0.37228 \times 10^{-10} T_B^2$$

; (18 < T_B < 520°C)

T_B : Temperature of bond layer (°C)

As for the thermal conductivity of bond layer, the thermal conductivity of Xe is used in the code.

4.4 Properties of light water and heavy water^{[24],[25]}

The properties of light water, heavy water used in the code are listed in Table 2 and Table 3.

Table 1 COOLOD Original Heat Transfer Correlations

Heat transfer mode		heat transfer correlation	
Single-phase forced-convection		$N_u = H_1 * (R_e^A - H_2) * P_r^B * \left[1.0 + H_3 \left(\frac{d}{z} \right)^C \right] * \left(\frac{\mu_b}{\mu_w} \right)^D$	
ONB Temperature		$q_i = 0.025293 P^{1.156} \left\{ \frac{9}{5} (T_c - T_{sat}) \right\}^{2.1615/P^{0.0234}}$	BERGLES - ROHSENOW
Nucleate boiling	Subcooled	$q_i = q_c + q_b$ $q_c = 0.023 (\lambda/D_e) R_e^{0.8} P_r^{0.4} (\Delta T_{sat} + \Delta T_{sub})$ $q_b = 4.50 e^{P/20} \Delta T_{sat}^{36} / 36000$	SATO - MATSUMURA
	Saturated	$\Delta T_{sat} = 11.2951 q_i^{0.25} e^{-P/63.0}$	JENS - LOTTES
DNB heat flux		$q_{BO} = 478800 (1 + 0.0365 v) (1 + 0.00507 \Delta T_{sub}) \times (1 + 0.0131 P)$	Mirshak, Durant and Towell
		$q_{BO} = \left(10890 \frac{D}{D + P_h / \pi} + 48 \frac{v}{D^{0.6}} \right) \times \left(102.6 \phi_1 P - 97.2 \frac{P}{P + 15} - \frac{v}{2.22} + 32 - (T_B)_{BO} \right)$	Bernath D : (ft) P _h : (ft) (T _B) _{BO} : (°F)
		$q_{BO} = 145.4 \theta_{(P)} (1 + 2.5 v^2 / \theta_{(P)})^{1/4} \times \left(1 + 15. \frac{C_P \Delta T_{sub}}{\lambda \sqrt{P}} \right)$ $\theta_{(P)} = 0.99531 P^{1/3} (1 - P/P_c)^{1/3}$	Labuntsov q _{BO} : (w/cm ²) P : (bar) P _c : (bar) v : (m/sec) C _P : (KJ/kg °C)

Table 2 Properties of Light Water

Temp. (°C)	Specific weight (kg/m ³)	Specific heat (kcal/kg°C)	Kinematic viscosity (m ² /s) x 10 ⁻⁶	Thermal conductivity (kcal/mh°C)	Thermal diffusivity (m ² /h) x 10 ⁻⁴	Dynamic viscosity (kg s/m ²) x 10 ⁻⁴	Surface tension (kg/m) x 10 ⁻³	Saturated pressure (kg/cm ²)	Enthalpy (kcal/kg)	
									Saturated water	Saturated vapor
0	999.9	1.008	1.79	0.489	4.85	1.829	7.72	0.006228	0.00 *1	597.49*1
10	999.7	1.002	1.31	0.505	5.04	1.336	7.56	0.012512	10.030	601.87
20	998.2	0.999	1.00	0.518	5.08	1.022	7.39	0.023826	20.030	606.23
30	995.7	0.998	0.803	0.531	5.34	0.816	7.24	0.043251	30.014	610.57
40	992.3	0.998	0.668	0.543	5.48	0.676	7.08	0.075204	39.995	614.88
50	988.1	0.999	0.555	0.552	5.59	0.559	6.90	0.12578	49.980	619.13
60	983.2	1.000	0.480	0.562	5.72	0.482	6.74	0.20313	59.972	623.32
70	977.8	1.001	0.417	0.571	5.85	0.416	6.55	0.31776	69.975	627.43
80	971.8	1.003	0.368	0.578	5.93	0.365	6.37	0.48294	79.993	631.45
90	965.3	1.005	0.328	0.583	6.01	0.323	6.19	0.71491	90.031	635.36
100	958.4	1.007	0.297	0.586	6.08	0.290	6.00	1.03323	100.092	639.15
120	943.1	1.014	0.247	0.589	6.16	0.238	5.55	2.0246	120.311	646.31
140	926.1	1.023	0.209	0.588	6.21	0.197	5.10	3.6850	140.705	652.78
160	907.3	1.037	0.186	0.585	6.22	0.172	4.65	6.3025	161.334	658.43
180	886.9	1.054	0.168	0.578	6.25	0.152	4.17	10.224	182.267	663.10
200	864.7	1.075	0.155	0.568	6.11	0.137	3.70	15.855	203.585	666.60
220	840.3	1.102	0.146	0.544	5.98	0.125	3.24	23.656	225.393	668.75
240	814	1.136	0.139	0.537	5.81	0.115	2.78	34.138	247.827	669.30
260	784	1.183	0.133	0.517	5.57	0.106	2.32	47.869	271.076	667.91
280	751	1.250	0.128	0.493	5.25	0.098	1.85	65.486	295.414	664.09
300	712	1.36	0.13	0.462	4.77	0.091	1.40	87.621	321.261	657.07
320	667	1.54	0.13	0.423	4.12	0.083	0.95	115.12	349.337	645.76

*1 0.01°C

Table 3 Properties of Heavy Water

Temp. (°C)	Specific weight (kg/m ³)	Specific heat (kcal/kg°C)	Kinematic viscosity (m ² /s) x 10 ⁻⁶	Thermal conductivity (kcal/mh°C)	Thermal diffusivity (m ² /h) x 10 ⁻⁴	Dynamic viscosity (kg s/m ²) x 10 ⁻⁴	Surface tension (kg/m) x 10 ⁻³	Saturated pressure (kg/cm ²)	Enthalpy (kcal/kg)	
									Saturated water	Saturated vapor
0	1105	1.015	0.7444	0.4782	4.266	0.7556	7.72	0.006954	1.201*1	554.65*1
10	1105	1.012	1.278	0.4882	4.364	1.319	7.56	0.01063	6.270	556.73
20	1105	1.009	1.135	0.5031	4.515	1.168	7.39	0.02067	16.373	560.83
30	1103	1.006	0.9044	0.5159	4.651	0.928	7.24	0.03827	26.483	564.87
40	1100	1.003	0.7297	0.5268	4.774	0.746	7.08	0.06780	36.477	568.86
50	1096	1.001	0.6034	0.5360	4.885	0.616	6.90	0.1153	46.494	572.78
60	1091	0.9991	0.5105	0.5434	4.985	0.520	6.74	0.1890	56.492	576.60
70	1085	0.9974	0.4405	0.5493	5.076	0.448	6.55	0.2994	66.473	580.37
80	1078	0.9959	0.3864	0.5537	5.157	0.392	6.37	0.4600	76.440	584.07
90	1071	0.9946	0.3438	0.5568	5.229	0.349	6.19	0.6871	86.393	587.68
100	1062	0.9937	0.3095	0.5586	5.291	0.314	6.00	1.001	96.331	591.22
120	1044	0.9932	0.2584	0.5587	5.387	0.262	5.55	1.984	116.189	598.00
140	1024	0.9959	0.2225	0.5547	5.438	0.226	5.10	3.641	136.061	604.38
160	1003	1.003	0.1963	0.5470	5.434	0.201	4.65	6.266	156.036	610.28
180	981.5	1.018	0.1765	0.5359	5.361	0.183	4.17	10.22	176.237	615.65
200	959.6	1.044	0.1611	0.5216	5.209	0.172	3.70	15.92	196.833	620.35
220	938.1	1.083	0.1489	0.5044	4.966	0.164	3.24	23.84	219.016	623.27
240	917.1	1.140	0.1390	0.4841	4.630	0.144	2.78	34.51	239.985	623.46
260	897.0	1.220	0.1308	0.4607	4.210	0.163	2.32	48.47	262.938	623.01
280	878.0	1.328	0.1339	0.4339	3.722	0.168	1.85	66.31	287.036	619.85
300	860.3	1.470	0.1180	0.4034	3.191	0.177	1.40	88.72	312.704	612.14
320	844.1	1.652	0.1129	0.3688	2.645	0.190	0.95	116.50	340.860	598.43

*1 5.0°C

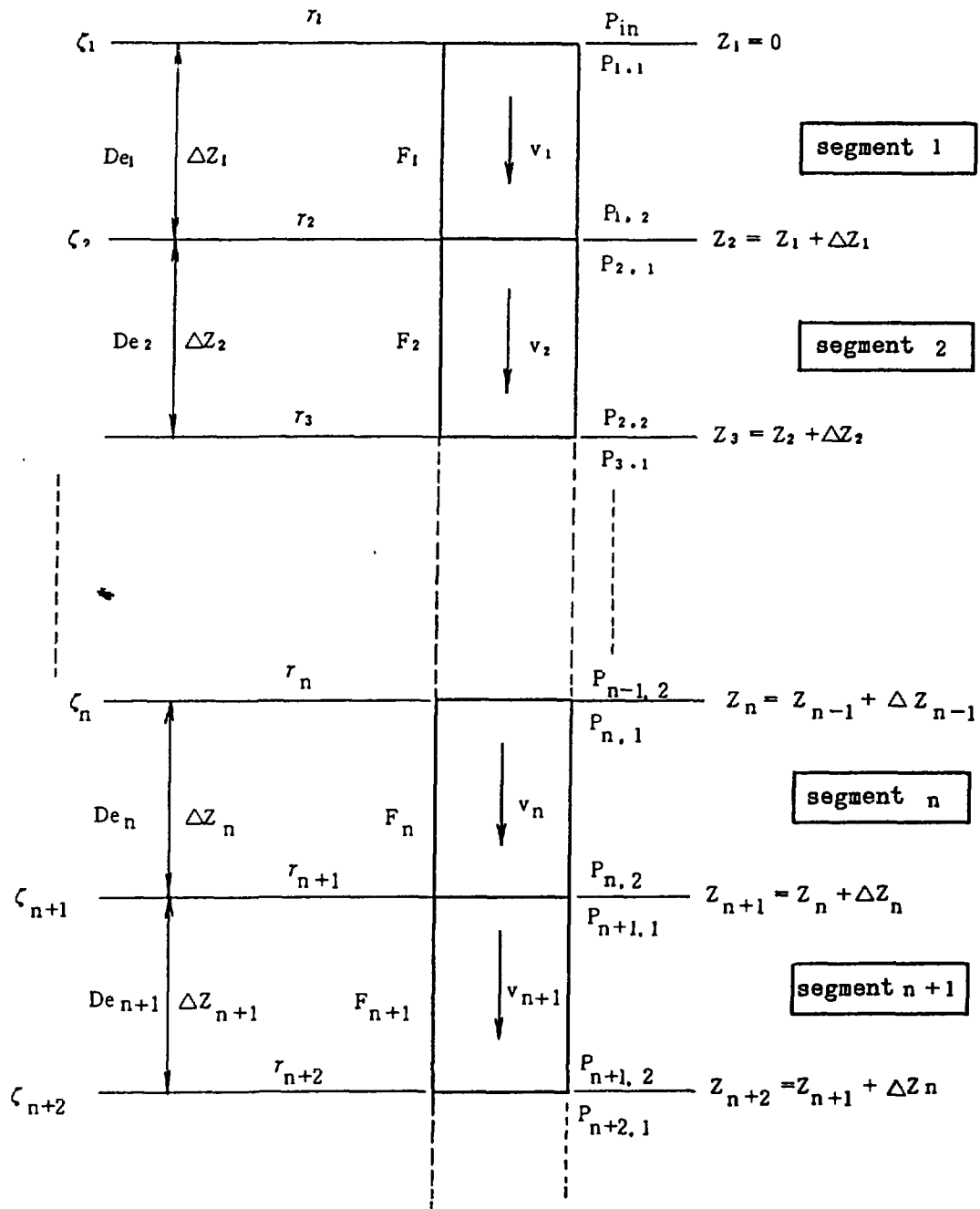

Fig. 7 Pressure Drop Calculation Model

5. Information of input data

<CARD A> Title card (A72)

TITL : Title for the calculation case

<CARD B1> Control card (Free format)

INFORM : Index for input data format (I)

- = 0 : COOLOD original type input data
- = 1 : **COOLOD-N** original type input data
FZ(CARD F4) are defined as points.
- = 2 : **COOLOD-N** original type input data
FZ(CARD F4) are defined as segments.

<CARD B2> Control card (Free format)

IAMAX : Number of calculation cases (I)

(1=<IAMAX<=10)

IMAX : Number of calculation points in fuel meat radial direction (I)

(1=<IMAX<=5)

JMAX : Number of calculation points for fuel plate axial direction (I)

(1=<JMAX<=21, INFORM=0,1(CARD B1))

(1=<JMAX<=20, INFORM=2(CARD B1))

(Number of CARD F4)

NMAX : Number of different fuel elements in the core (I)

(1=<NMAX<=5)

NPLOT : Plot option of calculation results (I)

= 0 : No plot

= 1 : Plot of calculation results

* NPLOT must be 0 in the COOLOD-N code MPR-30 version.

KEY(1) : Option for coolant temperature calculation (I)

= 0 : Cooling Tower, Heat Exchanger and Fuel temperature calculation

= 1 : Fuel temperature calculation only (Input data 'Tin' (primary coolant core inlet temperature) is required for calculation)

=-1 : Fuel temperature calculation skip

* KEY(1) must be 1 in the COOLOD-N code MPR-30 version

KEY(2) : Index for flow direction in the core (I)

= -1 : Upflow

= 0 : Horizontal flow

= 1 : Downflow

= 5 : Natural circulation cooling mode

KEY(3) : Index for coolant (I)

= 0 : Light water (H_2O)

= 1 : Heavy water (D_2O)

<CARD C> Thermal-hydraulic parameter (Free format)

QRR : Reactor thermal power (MW) (R)

PFLOW : Primary coolant flow rate or average coolant velocity in the core (R)

* If KVELO(CARD G1)=0, then PFLOW is Volumetric flow rate (m^3/min)

* If KVELO(CARD G1)=1, then PFLOW is Mass flow rate (kg/s)

* If KVELO(CARD G1)=2, then PFLOW is Average coolant velocity in the core (cm/s)

* If INFORM(CARD B1)=0, then PFLOW is Volumetric flow rate (m^3/min)

TIN : If KEY(1)=1 then the Primary coolant core inlet temperature ($^{\circ}C$) (R)

If KEY(1)=0 or -1 then the Wet bulb temperature ($^{\circ}C$) (R)

DT : Increment of inlet temperature "TIN" ($^{\circ}C$) (R)

JAMX : Number of calculation cases for "DT" (I) (Normally : =1)

<CARD D> Cooling Tower and Heat Exchanger data (Free format)

SFLOW : Secondary coolant flow rate (m^3/min) (R)

AFLOW : Air flow rate of the cooling tower (m^3/min) (R)

CTKI : Overall volumetric heat transfer coefficient based on enthalpy difference ($kcal/m^3h\Delta h$) (R)

HEKI : Heat transportation coefficient of the heat exchanger ($Kcal/m^2h^{\circ}C$) (R)

SSCT : Cross sectional area of the cooling tower (m^2) (R)

ZCT : Effective height of the cooling tower (m) (R)

SSHE : Heat transfer area of the heat exchanger (m^2) (R)

IHE : Heat exchanger type (I)
 = -1 : Counter flow type
 = 0 : Parallel flow type
 = ■ : Shell side ■ pass and tube side 2*■ pass type
 * **CARD D** is only used in case of KEY(1)<1(CARD B1).

<CARD E1> Heat transfer correlation (Free format)

H_1 , H_2 , H_3 , A, B, C, D, ITWC

H_1 - H_3 and A-D (R) and ITWC (I) are shown below.

$$Nu = \langle H_1 \rangle * (Re^{\langle A \rangle} - \langle H_2 \rangle) * Pr^{\langle B \rangle} * 1.0 + \langle H_3 \rangle \left(\frac{De}{Z} \right)^{\langle C \rangle} * \left(\frac{\mu_b}{\mu_w} \right)^{\langle D \rangle}$$

(Single phase heat transfer correlation)

Nu : Nusselt number (-)

Re : Reynolds number (-)

Pr : Prandtl number (-)

De : Equivalent hydraulic diameter (cm)

Z : Distance from inlet of channel (cm)

μ_b : Dynamic viscosity at bulk water temperature
(dynes/cm²)

μ_w : Dynamic viscosity at wall water temperature
(Surface temperature of fuel plate) (dynes/cm²)

ITWC : Standard temperature for property (I)

= 0 : Properties are evaluated by TWC(0)

TWC(0) = (Core inlet temperature + core outlet
temperature)/2.0

= 1 : Properties are evaluated by TWC(1)

TWC(1) = Bulk coolant temperature at Z.

= 2 : Properties are evaluated by TWC(2)

TWC(2) = (TWC(0) + Fuel surface temperature
at Z)/2.0

= 3 : Properties are evaluated by TWC(3)

TWC(3) = (TWC(1) + Fuel surface temperature
at Z)/2.0

* **CARD E1** is only used for the case of IHTC=1-3(**CARD G1**), if IHTC=4, then **CARD E1** is not used in the calculation, but dummy data are required even in the case of IHTC=4.

- <CARD E2> Core flow condition (Free format)
- FRATE : FRATE = (Effective flow rate for fuel plates cooling)
 /(Primary coolant flow rate) (-) (R)
- VIN : Coolant velocity in the inlet plenum (cm/s) (R)
- VOU : Coolant velocity in the outlet plenum (cm/s) (R)
- PRESSIN: Core inlet pressure (kg/cm²abs) (R)
- RAMF : Index for straight pipe friction loss for turbulent
 flow (R)
- = -1.0 : Blasius correlation
 = 0.0 : Karman-Nikuradse correlation
 = ϵ/De : Cole-Brook correlation
 ϵ/De is relative roughness.
- <CARD F1> Fuel element title card (A40)
- TITLN : Title for fuel element
- <CARD F2> Fuel element data (Free format)
- NPMX : Number of different fuel plates in this kind of fuel
 element (I)
 (Different cooling condition, different configuration)
 (1=<NPMX=<15)
 (Number of **CARD F51-CARD F53**)
- NFUEL : Number of this kind of fuel elements in the core (R)
- MA : Index for fuel meat material (I)
- = 0 : U-Al alloy
 = 1 : U-Al_x dispersion type
 = 2 : Fuel meat properties are inputed by data table
 (**CARD F22**)
- UDENST : Uranium density in meat (g/cm³) (R)
 (For U-Al and U-Al_x dispersion type fuel)
- POROTY : Porosity (-) (R)
 (For U-Al_x dispersion type fuel)
- IDPMX : Number of different configuration fuel plates in this
 kind of fuel element (I)
 (1=<IDPMX=<5)
 (Number of **CARD F6**)
- IDCMX : Number of different configuration flow channels in this

kind of fuel element (I)

(1=<IDCMX=<5)

(Number of **CARD F70**, **CRAD F74** or **CARD F76**)

EAREA : Effective flow area for this kind of fuel element (cm^2)
(R)

FRATEN : Flow rate distribution factor for this kind of fuel
element (-) (R)

FRATEN = (Flow rate of this kind of fuel element)
/(Average flow rate of fuel element)

<**CARD F22**> Fuel meat data table (Free format)

NUAL : Number of data sets (I)

TUAL : Temperature (-C) (R)

UAL : Thermal conductivity of the fuel meat (W/cm K)

* If MA<>2(**CARD F21**), then this card is not required.

<**CARD F3**> Hot channel factors (Free format)

FR : Radial peaking factor ($F_R(\text{radial}) \times F_E(\text{uncertainty})$) (R)

FCCOL : Engineering peaking factor for bulk coolant temperature
rise (R) (F_b)

FHFLX : Engineering peaking sub-factor for heat flux (R)
(This sub-factor is used in the calculation of DNBR)

FFILM : Engineering peaking factor for film temperature rise (R)
(F_f)

FCLAD : Engineering peaking factor for clad temperature rise (R)

FBOND : Engineering peaking factor for bond temperature rise (R)

FMEAT : Engineering peaking factor for fuel meat temperature
rise (R)

<**CARD F4**> Axial peaking factors (Free format)

FZ : Axial peaking factor (R)

* If INFORM=0 or 1(**CARD B1**), then FZ is defined as a point
($f(M_1)$).

* If INFORM=2(**CARD B1**), then FZ is defined as a segment
($f(S_1)$).

* If INFORM=0(**CARD B1**), then following data are not required.

In this case, DDZ is calculated as follows.

$$DDZ = HB / (JMAX - 1)$$

HB : **CARD F6**

DDZ : Distance from point_i(M_i) to point_{i+1}(M_{i+1}) or a segment length (R)

* If INFORM=1(**CARD B1**), then DDZ is distance from M_i to M_{i+1}(DDZ = ΔZ_i). In this case DDZ_{JMAX}(ΔZ_{JMAX}) is dummy data.

* If INFORM=2(**CARD B1**), then DDZ is a segment length (DDZ = ΔZ_i)

$$* \text{INFORM} = 1 : \sum_{j=1}^{JMA1-1} DDZ_j = HB \quad \text{HB : } \mathbf{CARD F6}$$

$$* \text{INFORM} = 2 : \sum_{j=1}^{JMAX} DDZ_j = HB$$

ZET : Resistance coefficient at point_i(M_i). (R)
(Normally : = 0.0)

* If INFORM=2(**CARD B1**), then f(M_i) are calculated as follows, using f(S_i).

$$f(M_1) = 2f(S_1) - f(M_2)$$

$$f(M_2) = f(S_1) + \frac{\Delta Z_1}{\Delta Z_1 + \Delta Z_2} [f(S_2) - f(S_1)]$$

$$f(M_3) = f(S_2) + \frac{\Delta Z_2}{\Delta Z_2 + \Delta Z_3} [f(S_3) - f(S_2)]$$

$$f(M_n) = f(S_{n-1}) + \frac{\Delta Z_{n-1}}{\Delta Z_{n-1} + \Delta Z_n} [f(S_n) - f(S_{n-1})]$$

$$f(M_{n \text{ max}}) = 2f(S_{n \text{ max}-1}) - f(M_{n \text{ max}-1})$$

See Fig.8.

<**CARD F51**> Fuel plate title card (A20)

TITLP : Title for fuel plate

<**CARD F52**> Fuel plate data (Free format)

NPLATE : Number of this kind of fuel plates in this kind of fuel element (R)

FLOCL : Local peaking factor (R)

IDPL : Identity number of fuel plate configuration (I)
(See **CARD F6**)

KMX : Index for cooling condition of fuel plate (I)
= 1 : Right hand side of fuel plate cooling condition

and left hand side of fuel plate cooling condition
are equal

= 2 : Right hand side of fuel plate cooling condition
and left hand side of fuel plate cooling condition
are not equal

IPLLOT : Plot option for the calculation results (I)

= 0 : No plot

= 1 : Channel No.1 side calculation results are plotted

= 2 : Channel No.2 side calculation results are plotted

= 3 : Both of channel No.1 and No.2 sides calculation
results are plotted

* Channel No. means ICHL of **CARD F53**.

** IPLLOT must be 0 in the COOLOD-N code MPR-30 version.

IOUT : Print out option for pressure, ONB, DNB and Heat flux at
onset of Flow instability calculation results (I)

= 0 : No print

= 1 : Print out of pressure, ONB and DNB calculation
results

* If INFORM=0(**CARD B1**), then meaning of IOUT is as
follows.

= 0 : No print

= 1 : Print out of pressure, ONB, DNB and Heat flux at
onset of Flow instability calculation results, DNB
heat flux is calculated by LABNTSOV correlation

= 2 : Print out of pressure, ONB, DNB and Heat flux at
onset of Flow instability calculation results, DNB
heat flux is calculated by MIRSHAK correlation

= 3 : Print out of pressure, ONB, DNB and Heat flux at
onset of Flow instability calculation results, DNB
heat flux is calculated by BERNATH correlation

<**CARD F53**> Coolant channel data (Free format)

ICHL : Identity number of channel configuration (I)

(See **CARD F70**, **CARD F74** or **CARD F76**)

NHEAT : Coolant condition (R)

= 1.0 : Coolant is heated from one side

= 2.0 : Coolant is heated from both sides

FRATEC : Flow rate distribution factor for this kind of channel
(R)

FRATEC = (Flow rate of this kind of channel)/(Average
flow rate of channel in this kind of fuel
element)

* This card is required KMX(CARD F52) sets.

* CARD F51-CARD F53 are required NPMX(CARD F21) sets.

<CARD F6> Fuel plate configuration data (Free format)

XA : Half thickness of fuel meat (cm) (R)
XB : Distance between fuel meat center and clad inner surface
(cm) (R) (Normally : XA=XB)
XC : Distance between fuel meat center and clad outer surface
(cm) (R) (Half thickness of fuel plate)
YA : Width of fuel meat (cm) (R)
HA : Distance between inlet of channel and top(bottom) of
fuel meat (cm) (R)
HB : Length of fuel meat (cm) (R)
HC : Distance between outlet of channel and bottom(top) of
fuel meat (cm) (R)

<CARD F70> Coolant channel configuration data (Free format) (If INFORM=0
(CARD B1), then this card is required.)

YCHI : Gap(thickness) of coolant channel (cm) (R)
XCHI : Width of coolant channel (cm) (R)

<CARD F71> Pressure loss calculation data (Fuel element entrance - plate
entrance) (Free format) (If INFORM=0(CARD B1), then this card is
required.)

ZETA(1): Resistance coefficient of fuel element entrance
(STRETCH(1)) (R)
DH(1) : Distance between fuel element entrance and fuel plate
entrance (cm) (R)
HDE(1) : Equivalent hydraulic diameter of this region (cm) (R)
AR(1) : Cross sectional area of this region (Flow area) (cm²)
(R)

<CARD F72> Pressure loss calculation data (Fuel plate exit - fuel element plug entrance) (Free format) (If INFORM=0(CARD B1), then this card is required.)

ZETA(2): Resistance coefficient of fuel element plug entrance
(STRETCH(3)) (R)

DH(2) : Distance between fuel plate exit and fuel element plug entrance (cm) (R)

HDE(2) : Equivalent hydraulic diameter of this region (cm) (R)

AR(2) : Cross sectional area of this region (Flow area) (cm²)
(R)

<CARD F73> Pressure loss calculation data (Fuel element plug entrance - fuel element exit) (Free format) (If INFORM=0(CARD B1), then this card is required.)

ZETA(3): Resistance coefficient of fuel element plug exit
(STRETCH(3)) (R)

DH(3) : Distance between fuel element plug entrance and fuel element exit (cm) (R)

HDE(3) : Equivalent hydraulic diameter of this region (cm) (R)

AR(3) : Cross sectional area of this region (Flow area) (cm²)
(R)

* CARD F70 - CARD F73 are required IDCX(CARD F21) sets.

* CARD F1 - CARD F73 are required NMAX(CARD B2) sets.

<CARD F74> Coolant channel configuration data (Free format) (If INFORM<>0 (CARD B1) and KEY(2)<>5(CARD B2), then this card is required.)

YCHI : Gap(thickness) of coolant channel (cm) (R)

XCHI : Width of coolant channel (cm) (R)

MSFLW : Number of segments, except fuel plate region.*1
(Number of CARD F75)

<CARD F75> Pressure loss calculation data (Free format) (If INFORM<>0(CARD B1) and KEY(2)<>5, then this card is required.)

ZETA : Resistance coefficient of this region entrance (R)

DH : Length of flow area (cm) (R)

ZLAM : Friction loss coefficient for laminar flow C_b^{**2} (R)

HDE : Equivalent hydraulic diameter of this region (cm) (R)
 AR : Cross sectional area of this region (Flow area) (cm²)
 (R)

* CARD F74 - CARD F75 are required IDCX(CARD F21) sets.

* CARD F1 - CARD F75 are required NMAX(CARD B2) sets.

<CARD F76> Coolant channel configuration data (Free format) (If INFORM<>0
 (CARD B1) and KEY(2)=5(CARD B2), then this card is required.)

YCHI : Gap(thickness) of coolant channel (cm) (R)

XCHI : Width of coolant channel (cm) (R)

MSFLW : Number of segments, include fuel plate region. *1 (In this
 case number of fuel plate region must be 1)
 (Number of CARD F77)

MSFUEL : Fuel plate region segment number (From top of segment)
 (I)

<CARD F77> Pressure loss calculation data (Free format) (If INFORM<>0(CARD
 B1) and KEY(2)=5, then this card is required.)

ZETA : Resistance coefficient of this region entrance (R)

DH : Length of flow area (cm) (R)

ZLAM : Friction loss coefficient for laminar flow C_b^{**2} (R)

HDE : Equivalent hydraulic diameter of this region (cm) (R)

AR : Cross sectional area of this region (Flow area) (cm²)
 (R)

* CARD F76 - CARD F77 are required IDCX(CARD F21) sets.

* CARD F1 - CARD F77 are required NMAX(CARD B2) sets.

<CARD G1> Control card (Free format) (If INFORM<>0(CARD B1), then this
 card is required.)

KVELO : Index for primary coolant flow rate (I)

= 0 : Volumetric flow rate (m³/min)

= 1 : Mass flow rate (kg/s)

= 2 : Average coolant velocity in the core (cm/s)

JUMAX : Number of non-heated flow segment of channel inlet side
 (I)

JLMAX : Number of non-heated flow segment of channel outlet
 side (I)

- * If $KEY(2) < 5$ (**CARD B2**), then $JUMAX+JLMAX=MSFLW$ (**CARD F74**)
 - * If $KEY(2)=5$ (**CARD B2**), then $JUMAX+JLMAX+1=MSFLW$ (**CARD F76**)
- IHTC : Index for heat transfer correlation (I)
- = 1-3 : COOLOD code original heat transfer correlation
(Single-phase heat transfer correlation is defined by **CARD E1**.)
 - =1 : DNB heat flux is calculated by LABUNTSOV correlation
 - =2 : DNB heat flux is calculated by MIRSHAK correlation
 - =3 : DNB heat flux is calculated by BERNATH correlation
 - = 4 : "Heat transfer package"
 - * "Heat transfer package" is developed for the upgraded JRR-3.
- KBFLG : Index for void fraction calculation in the natural (I) circulation cooling mode (I)
- = 0 : Void fraction is calculated in only nucleate boiling region (Zuber correlation)
 - > 0 : Void fraction is calculated in both nucleate boiling and subcooled boiling region. In subcooled boiling region, void fraction correlation is as follows.
 - = 1 : AHMAD correlation
 - = 2 : Zuber correlation
 - = 3 : If flow rate in the core $G(\text{kg/s}) < GLIM$ (**CARD G5**), then AHMAD correlation.
If flow rate in the core $G(\text{kg/s}) \geq GLIM$ (**CARD G5**), then Zuber correlation.
- * If forced convection cooling mode, then $KBFLG=0$
- NCMAX : Number of non-heated channel(Core bypass) (I)
- * If $KEY(2) < 5$ (**CARD B2**), then NCMAX must be 0.
- NATIP : Option for flow rate calculation in the natural circulation cooling mode (I)
- = 0 : Hot channel factors are not used in the calculation of flow rate in the natural circulation cooling mode.

= 1 : Hot channel factors are used in the calculation of flow rate in the natural circulation cooling mode.

* If KEY(2) <> 5(CARD B2), then NATIP must be 0.

<CARD G2> Core bypass data (1) (Free format) (If INFORM <> 0(CARD B1) and KEY(2) = 5(CARD B2), then this card is required.)

MSFLOW : Number of core bypass segments (I)

<CARD G3> Core bypass data (2) (Free format) (If INFORM <> 0(CARD B1) and KEY(2) = 5(CARD B2), then this card is required.)

ZETA : Resistance coefficient of this region entrance (R)

DH : Length of flow area (cm) (R)

ZLAM : Friction loss coefficient for laminar flow C_b^{**2} (R)

HDE : Equivalent hydraulic diameter of this region (cm) (R)

AR : Cross sectional area of this region (Flow area) (cm²) (R)

* This card is required MSFLOW(CARD G2) sets.

* CARD G2 and CARD G3 are required NCMAC(CARD G1) sets.

<CARD G4> Coolant channel configuration identity data (Free format) (If INFORM <> 0(CARD B1), then this card is required.)

JMSH : Flag for channel configuration (I)

* ((JMSH(NP,k), NP=1, NPMX), K=1, KMX)

* If KEY(2) <> 5(CARD B2), then this card is required MSFLW x NMAX(CARD B2) sets.

(MSFLW(CARD F74) = JUMAX(CARD G1) + JLMAX(CARD G1))

* If KEY(2) = 5(CARD B2), then this card is required MSFLW x (NMAX(CARD B2) + NCMAX(CARD G1)) sets.

(MSFLW(CARD F76) = JUMAX(CARD G1) + JLMAX(CARD G1) + 1)

<CARD G5> Void fraction calculation data (Free format) (If INFORM <> 0(CARD B1) and KEY(2) = 5(CARD B2), then this card is required.)

CB : Zuber constant (R)

* Zuber's constant = 1.18 or 1.41.

GLIM : Standard flow rate for void fraction calculation (kg/s) (R)

* GLIM is used only in the case of KBFLG = 3(CARD G1).

* The range of GLIM is 500~1500 ($\text{kg/m}^2\text{s}$).

<CARD G6> Debug control card (I)
 IDBG(I),I= 1,25
 IDBG(I),I=26,50
 IDBG : If you need debug the subroutine I, please input IDBG>=5
 See Table 4. (Normally : =0)

Following card are not required for COOLOD-N MPR-30 version.

<CARD P1> Plot control card (1)
 WITHX : Length of X axial (Maximum 200 mm) (mm) (R)
 WITHY : Length of Y axial (Maximum 230 mm) (mm) (R)
 TMIN : Minimum value of temperature scale ($^{\circ}\text{C}$) (R)
 TMAX : Maximum value of temperature scale ($^{\circ}\text{C}$) (R)
 PMIN : Minimum value of pressure scale ($\text{kg/cm}^2\text{abs}$) (R)
 PMAX : Maximum value of pressure scale ($\text{kg/cm}^2\text{abs}$) (R)
 HMIN : Minimum value of heat flux scale (W/cm^2) (R)
 HMAX : Maximum value of heat flux scale (W/cm^2) (R)

<CARD P2> Plot control card (2) (A4)
 NEWI : = "NEW" Plot on new page
 = "OLD" Plot on same page
 * In the first figure NEWI must be "NEW".

<CARD P3> Figure title card (A40)
 TITLE : Title of figure
 * If NEWI="OLD", then this card is not required.

<CARD P4> Plot control card (3) (I)
 IDPLOT(1)-(7), NSMBL(1)-(7)
 Plot items are listed as follows.
 (1) Coolant temperature
 (2) Clad surface temperature
 (3) Meat maximum temperatutre
 (4) Saturation temperature
 (5) ONB temperature
 (6) Pressure
 (7) Clad surface heat flux

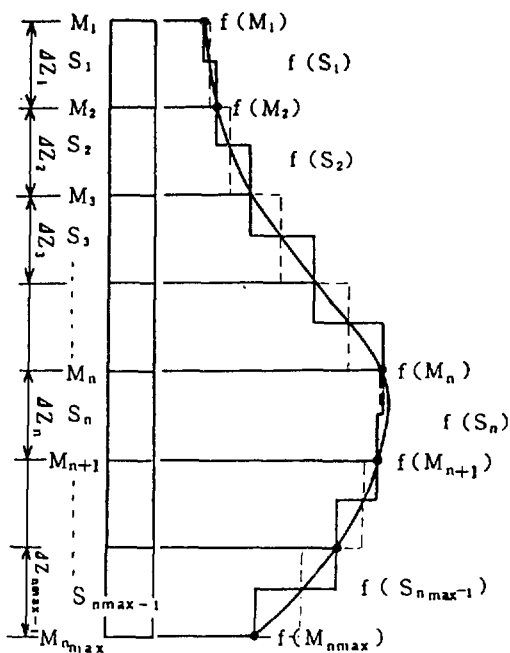

Fig. 8 Illustration of Axial Power Distribution used in the COOLOD-N Code

Table 4 Debug Flat - Subroutine

Subroutine	IDBG No.	Subroutine	IDBG No.
	1		26
	2	ONBTE	27
CALCTL	3	CLADTE	28
	4	BONDTE	29
	5	FUELTE	30
INITLZ	6	HEATBL	31
POWER	7	QHFPKG	32
TMPINL	8		33
	9	PRESS	34
DISPWZ	10	QDNB (=8)	35
QRATE	11		36
TMPCAL	12		37
	13		38
	14		39
	15	NATURE	40
VELOC, VELOC2	16	FLWGO	41
	17	DLTPD	42
	18	LOSTL	43
	19		44
NEWTON (=8)	20	GICAL	45
	21		46
	22	PBPH	47
	23	REN (=1)	48
COOLTE	24	UNITI	29
PRSDRP	25	UNITO	30

IDPLOT(I) : = 0 No plot
 = 11-15 Solid line is used
 = 21-25 Doted line is used

NSMBL(I) : = 0 No symbol
 = 1 is plotted on the line
 = 2 is plotted on the line
 = 3 is plotted on the line
 = 4 is plotted on the line
 = 11 is plotted on the line

*1

<CARD F74>

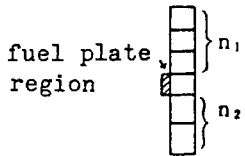

$$MSFLW=n_1+n_2$$

<CARD F76>

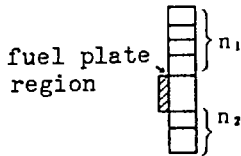

$$MSFLW=n_1+n_2+1$$

**2

$$F = \frac{C_b}{Re}$$

F : Friction loss coefficient

Re: Reynolds number

C_b : Tube $C_b = 64.0$

 Square $C_b = 56.9$

 Rectangular $C_b = 96.0$

 (Channel of fuel element)

6. Concluding Remarks

In this report, information required for users of the COOLOD-N code has been described. This work has been done as part of the thermal-hydraulic analysis of the upgraded JRR-3. After that, some modification were made for to cooperate with Badan Tenaga Atom Nasional (BATAN), Indonesia. A function to calculate the heat flux at onset of flow instability has been newly added to the COOLOD-N code to cooperate with BATAN. Heat flux at onset of flow instability is also important to evaluate safety margin of research reactors.

Acknowledgements

The author would like to express his heraty gratitude to Mr. M. Kawasaki Director of Department of Research Reactor Operation, to Mr. E. Shirai Deputy Director of Department of Research Reactor Operation and to Mr. N. Onishi Head of Research Reactor Development Division for their encouragements and suggestions.

References

- [1] S. Watanabe, COOLOD : Thermal and Hydraulic Analysis Code for Research Reactors with Plate Type Fuel Elements (in Japanese), JAERI-M 84-162, 1984.
- [2] Y. Sudo, H. Ando, H. Ikawa and N. Onishi, Core Thermohydraulic Design with 20% LEU Fuel for Upgraded Research Reactor JRR-3, J. Nucl. Sci. Technol., Vol.22, No.7, 551-564, 1985.
- [3] K. Arigane, S. Watanabe and H. Tsuruta, Neutronic and Thermo-hydraulic Design of LEU Core for Japan Research Reactor 4, JAERI-M 88-078, 1988.
- [4] M. Kaminaga, H. Ikawa, S. Watanabe, H. Ando and Y. Sudo, Thermohydraulic characteristics analysis of natural convection cooling mode on the steady state condition of upgraded JRR-3 core, using COOLOD-N code (in Japanese), JAERI-M 87-055, 1987.
- [5] Y. Sudo, H. Ikawa and M. Kaminaga, Development of Heat Transfer Package for Core Thermal-hydraulic Design and Analysis of Upgraded JRR-3, in Proceeding of the International Meeting of Reduced Enrichment for Research and Test Reactors, Petten, The Netherlands, October 14-16, 1985.
- [6] F. W. Dittus and L. M. K. Boelter, Univ. Calif. Pubs. Eng., 2, 443, 1930.
- [7] J. G. Collier, Convective Boiling and Condensation, McGraw-Hill Book Co., New York, 1972.
- [8] A. E. Bergles and W. H. Rohsenow, The determination of forced-convection surface-boiling heat transfer, ASME, Ser.C, 86, 365-372, 1964.
- [9] J. C. Chen, A correlation for boiling heat transfer to saturated fluids in convective flow, ASME paper No.63-HT-34.
- [10] Y. Sudo, K. Miyata, H. Ikawa, M. Kaminaga and M. Ohkawara, Experimental Study of Differences in DNB heat Flux between Upflow and Downflow in Vertical Rectangular Channel, J. Nucl. Sci. Technol., Vol.22, No.8, 604-618, 1985.
- [11] K. Mishima, Boiling burnout at low flow rate and low pressure conditions, Dissertation Thesis, Kyoto Univ., 1984.
- [12] R. H. Whittle and R. Forgan, A correlation for the minima in the Pressure Drop versus Flow-rate Curves for Sub-cooled Water Flowing in Narrow Heated Channels, Nucl. Eng. Design, 6, 89-99, 1967.

- [13] The Japan Society of Mechanical Engineers, Handbook of Mechanical Engineering (6th Edition) (in Japanese), Section 8, 13-15.
- [14] H. Uchida, Wet air and Cooling tower (in Japanese), Shoukado, 1963.
- [15] H. Obana, Handbook of Heat exchanger Design (in Japanese), Kougaku-Tosho, 1977.
- [16] Saha, Zuber, Point of net vapor generation and vapor void fraction in subcooled boiling, Proc. 5th Int. Heat Trans. Conf., Tokyo, 4, 175-179, 1974.
- [17] S. Y. Ahmad, Axial distribution of bulk temperature and void fraction in a heated channel with inlet subcooling, Trans. ASME, Ser.C, 92-4, 595-609, 1970.
- [18] N. Zuber, F. W. Stanb and G. Bijwaard, Vapor void fraction in subcooled boiling system, 3rd Int. Heat Transfer Conf., 5, 24-38, 1966.
- [19] P. G. Kroeger and N. Zuber, An analysis of the effects of various parameters on the average void fractions in subcooled boiling, Int. J. Heat Mass Transfer, 11, 211-233, 1968.
- [20] J. E. Houghtaling, Alain Sola and A. H. Spano, Transient Temperature Distribution in the SPERT1D-12/25 Fuel Plates during Short-Period Power Excursions, IDO-16884, 1964.
- [21] S. Nazare, G. Ondracek and F. Thummler, Investigation on UAl_x -Al Dispersion Fuels for High-Flux Reactors, J. Nucl. Materials, 56, 251-259, 1975.
- [22] Y. S. Touloukian et al., Thermophysical Properties of Matter, Vol.1, Thermal Conductivity, 1970.
- [23] Y. S. Touloukian et al., Thermophysical Properties of Matter, Vol.3, Thermal Conductivity, 288-289, 1970.
- [24] The Japan Society of Mechanical Engineers, Dennetsu-kougaku shiryo (3rd Edition) (in Japanese), 1976.
- [25] J. N. Elliott, Tables of the Thermodynamic Properties of Heavy Water, AECL-1673, 1963.

Appendix A Program Structure of the COOLOD-N code

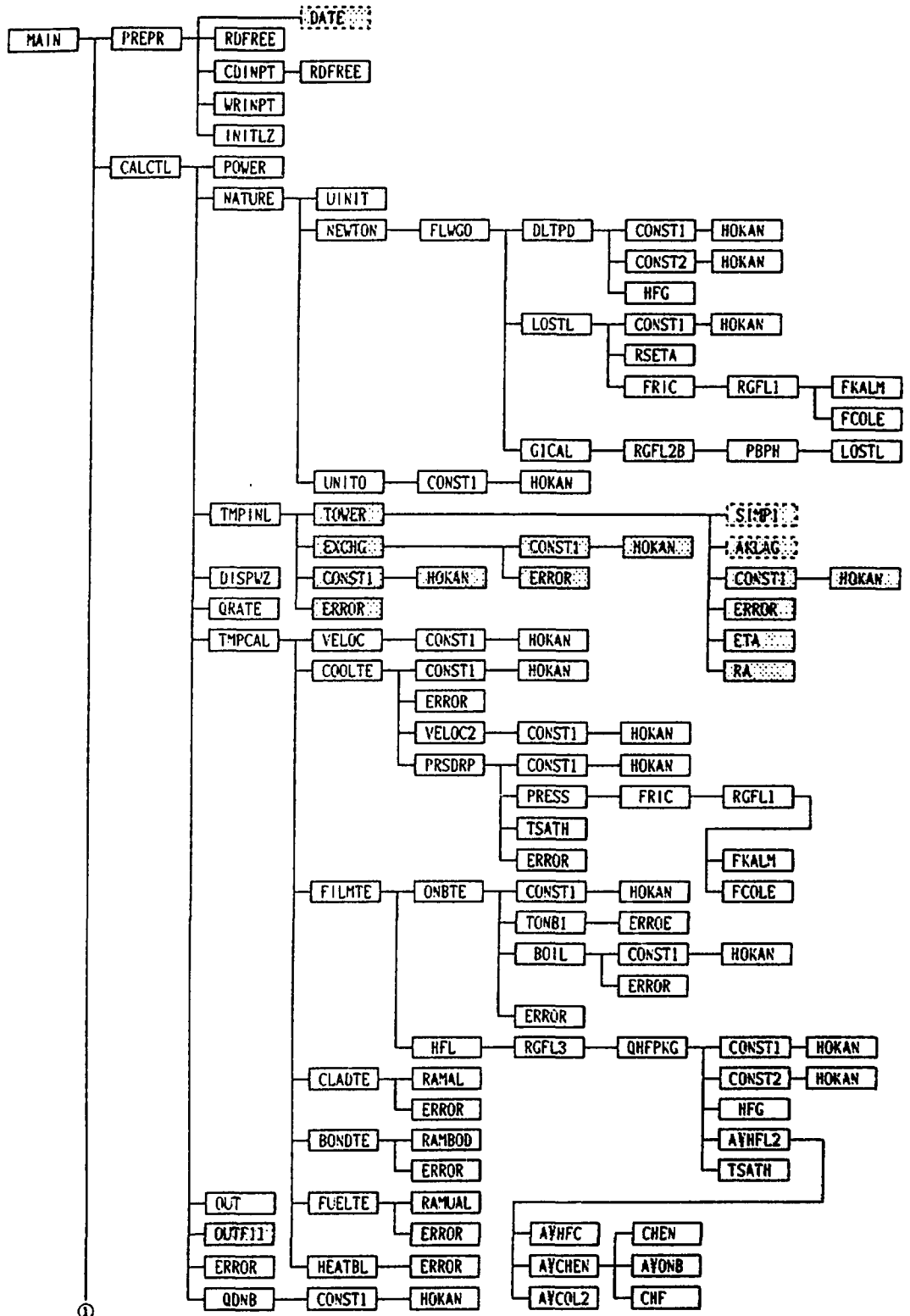

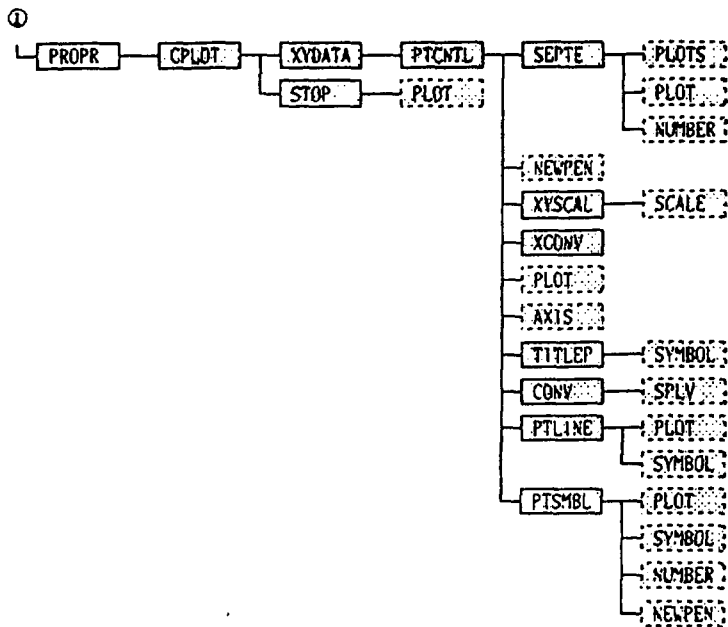

: System original subroutine., COOLOD-N(MPR-30 Version) can not use this subroutine.
 : COOLOD-N(MPR-30 Version) does not use this subroutine.

* MPR-30 (RSG-GA Siwabessy) is the design for a 30 MW, MTR-type multi-purpose research and test reactor that is cooled and moderated by a light water and uses fuels containing 19.75% enriched uranium. The reactor is located at the PUSPIPTEK area in Serpon, Indonesia, and belongs to National Atomic Energy Agency (Badan Tenaga Atom Nasional, BATAN), Republic Indonesia.

```

      INPUT CARD F51          INPUT CARD F52          INPUT CARD F53
      PLATE NAME             NPLATE FLOCL IDPL   KMx  IPLGT  IOUT             K  ICHL  NHEAT  FRATEC
MP= 1  STANDARD FUEL PLATE   20.0  1.510    1     1     1     1             1  1    2.0  1.0000

      INPUT CARD F6          IDP    XAI    XBI    XCI    YAI    HAI    HBI    HCI
                               1    0.038  0.038  0.076  6.160  1.000  75.000  1.000

      INPUT CARD F74          INPUT CARD F75
      IDC    XCHI    YCHI    MSFLW          IS    ZETA    DH    ZLAM    DE    AREA
        1    0.228  6.660    3                               1    0.691  0.0    0.0    1.000  30.500
                                                2    0.0    0.0    0.0    1.000  30.500
                                                3    0.317  0.0    0.0    1.000  30.500

      INPUT CARD <G1>      KVELO  JUNAX  JLMAX  IHTC  KBFLG  NCHAX  NATIP
                               1      1      2      4      0      0      0

      INPUT DATA FORMAT => COOLOD ORIGINAL
      VELOCITY(-D) MASS FLOW RATE(-I)>>  1
      UPPER PRENUM MESH=  1 FUEL PLATE MESH=  16 LOWER PRENUM MESH=  2
      JMSH  MN=  1 MSFLW=  3 NPMAX=  1 KMAX=  1 KEY(2)=  1
        1  1
        2  2
        3  3
      MN=  1 JFMAX=  3 JMSH=  1  2  3

      IDBG
        1  2  3  4  5  6  7  8  9 10 11 12 13 14 15 16 17 18 19 20 21 22 23 24 25
        0  0  0  0  0  0  0  0  0  0  0  0  0  0  0  0  0  0  0  0  0  0  0  0
      26 27 28 29 30 31 32 33 34 35 36 37 38 39 40 41 42 43 44 45 46 47 48 49 50
        0  0  0  0  0  0  0  0  0  0  0  0  0  0  0  0  0  0  0  0  0  0  0  0

```

Appendix B Sample Calculation Results

1. Sample calculation result for forced convection

(1) Input data

COOLOD-N THERMAL HYDRAULIC CALCULATION

CALCULATION DATE 89-08-04 PAGE 1

```
*****
**** COOLOD-N THERMAL HYDRAULIC CALCULATION ( JRR3001 ) ****
****                CALCULATION DATE 89-08-04                ****
****                INITIAL INPUT DATA                        ****
*****
```

```
INPUT CARD D1      INFORM
                    1

INPUT CARD R2      IMAX      IMAX      JMAXN      NMAX      NPLOT      KEY(1)      KEY(2)      KEY(3)
                    1         5         16         1         1         1         1         0

INPUT CARD C
  QRR      PFLOW      TIN      DT      JAHX
CASE 1    20.000    662.667    35.000    0.0     1

INPUT CARD E1      H1      H2      H3      A      B      C      D      ITWC
                    0.023    0.0     0.0     0.800    0.400    0.0     0.0     1

INPUT CARD E2      FRATE      VIN      VOUT      PRESIN      RAMF
                    0.8073    0.0     0.0     1.5500    0.0004

INPUT CARD F1      STANDARD FUEL

INPUT CARD F21     NPMX      NFUEL      MA      UDEWST      POROITY      IDPMX      IDCMX      EAREA      FRATEN
                    1         28.5      2         2.200      0.057      1         1         30.500    1.000

INPUT CARD F22
  NUMBER OF THERMAL CONDUCTIVITY OF INPUT DATA TABLE 2
  0.0      0.7700      500.0      0.7700

INPUT CARD F3      FR      FCOOL      FFILM      FHFLX      FCLAD      FBOND      FHEAT
                    1.450    1.330    1.370    1.170    1.000    1.000    1.000

INPUT CARD F4      J      FZ      O02      ZET
                    1     0.3970    5.000    0.0
                    2     0.4280    5.000    0.0
                    3     0.5330    5.000    0.0
                    4     0.6420    5.000    0.0
                    5     0.7490    5.000    0.0
                    6     0.8670    5.000    0.0
                    7     0.9980    5.000    0.0
                    8     1.2120    5.000    0.0
                    9     1.3730    5.000    0.0
                   10     1.4160    5.000    0.0
                   11     1.4180    5.000    0.0
                   12     1.3700    5.000    0.0
                   13     1.2710    5.000    0.0
                   14     1.1140    5.000    0.0
                   15     0.9550    5.000    0.0
                   16     0.9000    5.000    0.0
```

(2) Output

COOLOD-N THERMAL HYDRAULIC CALCULATION CASE = (JA- 1 JA- 1)

CALCULATION DATE 89-08-04 PAGE 2

```
*****  
** COOLOD-N THERMAL HYDRAULIC CALCULATION ( JRR3001 ) **  
** RESULTS OF CALCULATION AND USED VALUES **  
*****
```

```
*** PRIMARY COOLANT ***  
REACTOR INLET TEMPERATURE = 35.00 C  
REACTOR OUTLET TEMPERATURE = 42.22 C  
PRIMARY TEMPERATURE DIFFERENCE = 7.22 C  
PRIMARY COOLANT FLOW RATE = 662.67 KG/S
```

```
*** REACTOR CORE ****  
REACTOR THERMAL POWER = 20.00 MW  
AREA OF TOTAL FUEL CHANNELS = 868.06 CM2
```

```
NUMBER OF FUEL ELEMENTS = 28.5 ELEMNTS
```

```
STANDARD FUEL = 28.5 (ELEMNTS)  
AVERAGE HEAT GENERATION = 1000.53 (W/CM3)  
AVERAGE MASS FLUX = 6162.672 (KG/M2 SEC)
```

```
COOLANT TEMP. -- (SEPARATED MODEL) KITE = 0
```

Average heat flux

= Average heat generation x XA (CARD F6)

(XA : Halfthickness of fuel meat)

 ** STANDARD FUEL **

 AVERAGE CHANNEL TEMPERATURE DISTRIBUTION

FLOW CHANNEL AREA = 30.50 CM2
 NUMBER OF FUEL PLATES
 STANDARD FUEL PLATE= 20.0

J	COOLANT (DEG.C)	TEMPERATURE DISTRIBUTION			FUEL HEAT OUTER (DEG.C)	FUEL HEAT MAXIMUM (DEG.C)
		CLADDING SURFACE (DEG.C)	CLADDING INNER (DEG.C)	FUEL HEAT INNER (DEG.C)		
1	35.00	40.42	40.76	40.76	41.14	
2	35.25	41.08	41.45	41.45	41.85	
3	35.53	42.78	43.24	43.24	43.74	
4	35.89	44.58	45.14	45.14	45.74	
5	36.30	46.41	47.06	47.06	47.76	
6	36.79	48.44	49.19	49.19	50.00	
7	37.35	50.69	51.55	51.55	52.48	
8	38.01	54.11	55.15	55.15	56.29	
9	38.78	56.89	58.07	58.07	59.36	
10	39.62	58.15	59.37	59.37	60.69	
11	40.47	58.89	60.10	60.10	61.43	
12	41.30	58.98	60.16	60.16	61.44	
13	42.09	58.39	59.48	59.48	60.67	
14	42.81	57.00	57.96	57.96	59.01	
15	43.42	55.53	56.36	56.36	57.25	
16	43.98	55.34	56.11	56.11	56.96	

** HOT CHANNEL FACTORS (EXCEPT FZ) **
 F(COOLANT)= 1.000 F(FILM)= 1.000 F(CLAD)= 1.000 F(BOND)= 1.000 F(MEAT)= 1.000

J	FZ	HEAT TRANSFER CONDITION				HEAT GENERATION (W/CM3)
		TRANSFER COEFFICIENT (W/CM2.C)	HEAT FLUX IN PLATE SURFACE (W/CM2)	FLUX (KC/IN2.HR)	XAA (CM)	
1	0.397	2.7843	15.094	0.12978E+06	0.038	397.212
2	0.428	2.7905	16.273	0.13991E+06	0.038	428.229
3	0.533	2.7976	20.265	0.17424E+06	0.038	533.285
4	0.642	2.8065	24.409	0.20987E+06	0.038	642.343
5	0.749	2.8170	28.477	0.24485E+06	0.038	749.400
6	0.867	2.8294	32.964	0.28342E+06	0.038	867.463
7	0.998	2.8439	37.944	0.32625E+06	0.038	998.533
8	1.212	2.8613	46.081	0.39620E+06	0.038	1212.646
9	1.373	2.8821	52.202	0.44883E+06	0.038	1373.734
10	1.416	2.9050	53.837	0.46289E+06	0.038	1416.757
11	1.418	2.9266	53.913	0.46354E+06	0.038	1418.757
12	1.370	2.9463	52.088	0.44785E+06	0.038	1370.731
13	1.271	2.9654	48.324	0.41549E+06	0.038	1271.678
14	1.114	2.9829	42.355	0.36417E+06	0.038	1114.594
15	0.955	2.9984	36.309	0.31219E+06	0.038	955.510
16	0.900	3.0124	34.218	0.29421E+06	0.038	900.481

↙ Average heat flux x FZ (CARD F4)
 (FZ : Axial peaking factor)

$$F(\text{COOLANT}) = FR \times \text{FLOCL} \times \text{FCOOL}$$

$$F(\text{FILM}) = FR \times \text{FLOCL} \times \text{FFILM}$$

$$F(\text{CLAD}) = FR \times \text{FLOCL} \times \text{FCLAD}$$

$$F(\text{BOND}) = FR \times \text{FLOCL} \times \text{FBOND}$$

$$F(\text{MEAT}) = FR \times \text{FLOCL} \times \text{FMEAT}$$

STANDARD FUEL PLATE (STANDARD FUEL)

CHANNEL DIMENSION = 0.278 * 6.660 (CM)
 CHANNEL VELOCITY = 622.90 (CM/SEC)

I	J	TEMPERATURE DISTRIBUTION					I
		COOLANT (DEG.C)	CLADDING SURFACE (DEG.C)	CLADDING INNER (DEG.C)	FUEL HEAT OUTER (DEG.C)	FUEL HEAT MAXIMUM (DEG.C)	
I	1	35.00	51.26	52.01	52.01	52.82	I
I	2	35.72	53.14	53.94	53.94	54.82	I
I	3	36.56	58.09	59.09	59.09	60.18	I
I	4	37.58	63.27	64.48	64.48	65.79	I
I	5	38.80	68.43	69.83	69.83	71.37	I
I	6	40.20	74.06	75.68	75.68	77.46	I
I	7	41.83	80.29	82.15	82.15	84.20	I
I	8	43.76	89.73	91.98	91.98	94.47	I
I	9	46.01	97.03	99.57	99.57	102.39	I
I	10	48.44	99.57	102.19	102.19	105.09	I
I	11	50.91	100.68	103.30	103.30	106.21	I
I	12	53.34	100.39	102.92	102.92	105.74	I
I	13	55.64	98.59	100.94	100.94	103.55	I
I	14	57.72	95.03	97.09	97.09	99.38	I
I	15	59.52	91.26	93.03	93.03	94.99	I
I	16	61.13	90.58	92.25	92.25	94.09	I

** HOT CHANNEL FACTORS (EXCEPT FZ) **

F(COOLANT)= 2.912 F(FILM)= 3.000 F(CLAD)= 2.189 F(BOND)= 2.189 F(HEAT)= 2.189

I	J	FZ	HEAT TRANSFER CONDITION				I	
			TRANSFER COEFFICIENT (W/CM2.C)	H E A T IN PLATE (W/CM2)	F L U X SURFACE (KC/M2.HR)	XAA (CM)		H E A T GENERATION (W/CM3)
I	1	0.397	2.7844	45.276	0.38929E+06	0.038	1191.481	I
I	2	0.428	2.8023	48.812	0.41969E+06	0.038	1284.520	I
I	3	0.533	2.8235	60.787	0.52265E+06	0.038	1599.646	I
I	4	0.642	2.8501	73.218	0.62953E+06	0.038	1926.780	I
I	5	0.749	2.8825	85.421	0.73445E+06	0.038	2247.910	I
I	6	0.867	2.9205	98.878	0.85016E+06	0.038	2602.053	I
I	7	0.998	2.9591	113.818	0.97861E+06	0.038	2995.213	I
I	8	1.212	3.0068	138.224	0.11885E+07	0.038	3637.470	I
I	9	1.373	3.0693	156.585	0.13463E+07	0.038	4120.668	I
I	10	1.416	3.1586	161.489	0.13885E+07	0.038	4249.719	I
I	11	1.418	3.2494	161.717	0.13905E+07	0.038	4255.719	I
I	12	1.370	3.3206	156.243	0.13434E+07	0.038	4111.660	I
I	13	1.271	3.3746	144.953	0.12463E+07	0.038	3814.543	I
I	14	1.114	3.4050	127.047	0.10924E+07	0.038	3343.351	I
I	15	0.955	3.4316	108.914	0.93645E+06	0.038	2666.160	I
I	16	0.900	3.4857	102.641	0.88252E+06	0.038	2701.094	I



Average heat flux x FR x FFILM (CARD F3) x FZ (CARD F4)

(FR : Radial peaking factor)

(FFILM : Film temperature rising factor)

(FZ : Axial peaking factor)

STANDARD FULL PLATE (PRESSURE , QWB & DNR CONDITION)

		PRESSURE AT Z (KG/CM ² A)	PRESSURE LOSS (KG/CM ²)	TOTAL LOSS (KG/CM ²)	COOLANT VELOCITY (CM/SEC)	TSAT (C)	TQWB (C)	TCLAD (C)	DIOND	HEAT CLAD QWB	FLUX (W/CM ²) QWB QDWB DNR	DNB ID		
I INLET	PLENUM	1.550			0.0									
I STRETCH(1)	INLET	1.220	0.13470	0.13470	619.99									
I STRETCH(1)	OUT	1.220	0.0	0.13470	619.99									
I PLATE	ENTRANCE	1.220	0.0	0.13470	619.99									
I FUEL PLATE ZONE 1		1.211	0.01039	0.14510	619.99	104.51	112.89	51.26	61.63	38.67	0.0	324.90	8.40	2.0
I FUEL PLATE ZONE 2		1.164	0.05192	0.19701	620.14	103.37	112.22	53.14	59.08	41.69	0.0	324.90	7.79	2.0
I FUEL PLATE ZONE 3		1.117	0.05186	0.24880	620.32	102.20	112.19	58.09	54.10	51.91	0.0	324.90	6.26	2.0
I FUEL PLATE ZONE 4		1.071	0.05179	0.30043	620.54	100.99	112.10	63.27	48.83	62.53	0.0	324.90	5.20	2.0
I FUEL PLATE ZONE 5		1.024	0.05171	0.35186	620.79	99.75	111.93	68.43	43.50	72.95	0.0	324.90	4.45	2.0
I FUEL PLATE ZONE 6		0.978	0.05161	0.40305	621.10	98.46	111.77	74.06	37.71	84.44	0.0	324.90	3.85	2.0
I FUEL PLATE ZONE 7		0.932	0.05150	0.45401	621.53	97.13	111.65	80.29	31.36	97.20	0.0	324.90	3.34	2.0
I FUEL PLATE ZONE 8		0.886	0.05137	0.50460	622.04	95.75	112.01	89.73	22.28	118.05	0.0	324.90	2.75	2.0
I FUEL PLATE ZONE 9		0.841	0.05124	0.55485	622.63	94.33	111.95	97.03	14.93	133.73	2.67	324.90	2.43	2.0
I FUEL PLATE ZONE 10		0.796	0.05111	0.60487	623.28	92.85	111.12	99.57	11.55	137.91	18.26	324.90	2.36	2.0
I FUEL PLATE ZONE 11		0.751	0.05098	0.65465	623.97	91.30	110.00	100.68	9.32	138.11	35.49	324.90	2.35	2.0
I FUEL PLATE ZONE 12		0.706	0.05085	0.70477	624.72	89.68	108.55	100.39	8.16	133.43	44.56	324.90	2.43	2.0
I FUEL PLATE ZONE 13		0.662	0.05074	0.75370	625.44	87.98	106.75	98.59	8.16	123.79	40.91	324.90	2.62	2.0
I FUEL PLATE ZONE 14		0.617	0.05063	0.80301	626.09	86.18	104.46	95.03	9.43	108.50	25.63	324.90	2.99	2.0
I FUEL PLATE ZONE 15		0.573	0.05053	0.85228	626.65	84.28	101.93	91.26	10.68	93.01	14.15	324.90	3.49	2.0
I FUEL PLATE ZONE 16		0.529	0.05045	0.90157	627.19	82.24	100.02	90.58	9.44	87.66	19.21	324.90	3.71	2.0
I WURST CONDITION		0.529				81.81	99.59			138.11	21.47	324.90	2.35	2.0
I PLATE	EXIT	0.520	0.01009	0.91166	627.19									
I STRETCH(2)	INLET	0.520	0.0	0.91166	627.19									
I STRETCH(2)	OUT	0.520	0.0	0.91166	627.19									
I STRETCH(3)	INLET	0.520	0.0	0.91166	627.19									
I STRETCH(3)	OUT	0.520	0.0	0.91166	627.19									
I OUTLET	PLENUM	0.654	0.06251	0.97418	0.0									

----- DNBID=1 Q1=0.005*G**0.611 ----- DNBID=2 Q2=(A/AH)(DNH/HFG)=G ----- DNBID=3 Q3=0.7(A/AH)RT(U/R)/RT(1+(RG/RL)**0.25) -----

----- TCLAD < TSAT

HEAT FLUX OF CLAD --- Q=FR*FH=FL

(COLE - BROOK EQUATION WAS USED FOR WALL LOSS CALCULATION)

Average heat flux x FR x FFILM x FLOCL x FZ x (FHFLX / FFILM)
 = Average heat flux x FR x FHFLX x FLOCL x FZ

STANDARD FULL PLATE (ONSET OF FLOW INSTABILITY CONDITION)

		PRESSURE AT Z (KG/CM2A)	PRESSURE LOSS (KG/CM2)	TOTAL LOSS (KG/CM2)	COOLANT VELOCITY (CM/SEC)	TSAT (C)	T0NB (C)	TCLAD (C)	DIONB	HEAT CLAD	FLUX QONB	QOFI (W/CM2)	OFIR
I INLET	PLENUM	1.550			0.0								
I STRETCH(1)	INLET	1.220	0.13470	0.13470	619.99								
I STRETCH(1)	OUT	1.220	0.0	0.13470	619.99								
I PLATE	ENTRANCE	1.220	0.0	0.13470	619.99								
I FUEL PLATE ZONE 1		1.211	0.01039	0.14510	619.99	104.51	112.89	51.26	61.63	38.67	= 0.0	279.05	7.22
I FUEL PLATE ZONE 2		1.164	0.05192	0.19701	620.14	103.37	112.22	53.14	59.08	41.69	= 0.0	279.05	6.69
I FUEL PLATE ZONE 3		1.117	0.05186	0.24880	620.32	102.20	112.19	58.09	54.10	51.91	= 0.0	279.05	5.38
I FUEL PLATE ZONE 4		1.071	0.05179	0.30043	620.54	100.99	112.10	63.27	48.83	62.53	= 0.0	279.05	4.46
I FUEL PLATE ZONE 5		1.024	0.05171	0.35186	620.79	99.75	111.93	68.43	43.50	72.95	= 0.0	279.05	3.83
I FUEL PLATE ZONE 6		0.978	0.05161	0.40305	621.10	98.46	111.77	74.06	37.71	84.44	= 0.0	279.05	3.30
I FUEL PLATE ZONE 7		0.932	0.05150	0.45401	621.53	97.13	111.65	80.29	31.36	97.20	= 0.0	279.05	2.87
I FUEL PLATE ZONE 8		0.886	0.05137	0.50460	622.04	95.75	112.01	89.73	22.28	118.05	= 0.0	279.05	2.36
I FUEL PLATE ZONE 9		0.841	0.05124	0.55485	622.63	94.33	111.95	97.03	14.93	133.73	2.67	279.05	2.09
I FUEL PLATE ZONE 10		0.796	0.05111	0.60487	623.28	92.85	111.12	99.57	11.55	137.91	18.26	279.05	2.02
I FUEL PLATE ZONE 11		0.751	0.05098	0.65465	623.97	91.30	110.00	100.68	9.32	138.11	35.49	279.05	2.02
I FUEL PLATE ZONE 12		0.706	0.05085	0.70427	624.72	89.68	108.55	100.39	8.16	133.43	44.56	279.05	2.09
I FUEL PLATE ZONE 13		0.662	0.05074	0.75370	625.44	87.98	106.75	98.59	8.16	123.79	40.91	279.05	2.25
I FUEL PLATE ZONE 14		0.617	0.05063	0.80301	626.09	86.18	104.46	95.03	9.43	108.50	25.63	279.05	2.57
I FUEL PLATE ZONE 15		0.573	0.05053	0.85228	626.65	84.28	101.93	91.26	10.68	93.01	14.15	279.05	3.00
I FUEL PLATE ZONE 16		0.529	0.05045	0.90157	627.19	82.24	100.02	90.58	9.44	87.66	19.21	279.05	3.18
I #WORST CONDITION#		0.529				81.81	99.59			138.11	21.47	279.05	2.02
I PLATE	EXIT	0.520	0.01009	0.91166	627.19								
I STRETCH(2)	INLET	0.520	0.0	0.91166	627.19								
I STRETCH(2)	OUT	0.520	0.0	0.91166	627.19								
I STRETCH(3)	INLET	0.520	0.0	0.91166	627.19								
I STRETCH(3)	OUT	0.520	0.0	0.91166	627.19								
I OUTLET	PLENUM	0.654	0.06251	0.97418	0.0								

HEAT FLUX AT ONSET OF FLOW INSTABILITY --- QOFI = A*ADS(GM)*DNI/(AH**25*A)

--- TCLAD < TSAT

HEAT FLUX OF CLAD --- Q=FR*FN=FL

(COLE - BROOK EQUATION WAS USED FOR WALL LOSS CALCULATION)

Heat flux at onset of Flow instability

$$OFIR = \frac{\text{Heat flux at onset of Flow instability}}{\text{Heat flux at Z}}$$

-----PLOT INPUT DATA FROM FT05 -----4-----5-----6-----7-----

WITHX WITHY THIN THAX PHIN PMAX HMIN HMAX
 150.000 150.000 0.0 150.000 0.0 2.000 0.0 200.000

NEVI= NEV

TITLE= FORCED CONVECTION (JRR3001)

IDPLOT= 1 IDPLOT= 2 IDPLOT= 3 IDPLOT= 4 IDPLOT= 5 IDPLOT= 6 IDPLOT= 7
 11 13 23 14 12 22 21
 NSMBL = 1 NSMBL = 2 NSMBL = 3 NSMBL = 4 NSMBL = 5 NSMBL = 6 NSMBL = 7
 0 0 0 0 0 0 0

-----PLOT INPUT DATA FROM FT11 -----4-----5-----6-----7-----

IA= 1 JA= 1 K= 1 NP= 1 K= 1

J	X(J)	TCOOLANT	TCLAD	TMEAT	TSAT	TOWD	PRESS	HEAT FLUX
1	0.0	35.00	51.26	52.82	104.51	112.89	1.21096	45.28
2	5.000	35.72	53.14	54.82	103.32	112.22	1.16401	48.81
3	10.000	36.56	58.09	60.18	102.20	112.19	1.11719	60.79
4	15.000	37.58	63.27	65.79	100.99	112.10	1.07052	73.22
5	20.000	38.80	68.43	71.37	99.75	111.93	1.02406	85.42
6	25.000	40.20	74.06	77.46	98.46	111.77	0.97783	98.88
7	30.000	41.83	80.29	84.20	97.13	111.65	0.93183	113.82
8	35.000	43.76	89.73	94.47	95.75	112.01	0.88619	138.22
9	40.000	46.01	97.03	102.39	94.33	111.95	0.84089	156.59
10	45.000	48.44	99.57	105.09	92.85	111.12	0.79580	161.49
11	50.000	50.91	100.68	106.21	91.30	110.00	0.75095	161.72
12	55.000	53.14	100.39	105.74	89.68	108.55	0.70626	156.24
13	60.000	55.64	98.59	103.55	87.98	106.75	0.66176	144.95
14	65.000	57.72	95.03	99.38	86.18	104.46	0.61737	127.05
15	70.000	59.52	91.26	94.99	84.28	101.93	0.57301	108.93
16	75.000	61.13	90.58	94.09	82.24	100.02	0.52864	102.64

PLOT START, JMAX3= 19

IJ = 1 PLOT END
 II = 2 PLOT END
 IJ = 3 PLOT END
 II = 4 PLOT END
 IJ = 5 PLOT END
 II = 6 PLOT END
 IJ = 7 PLOT END

NORMAL END

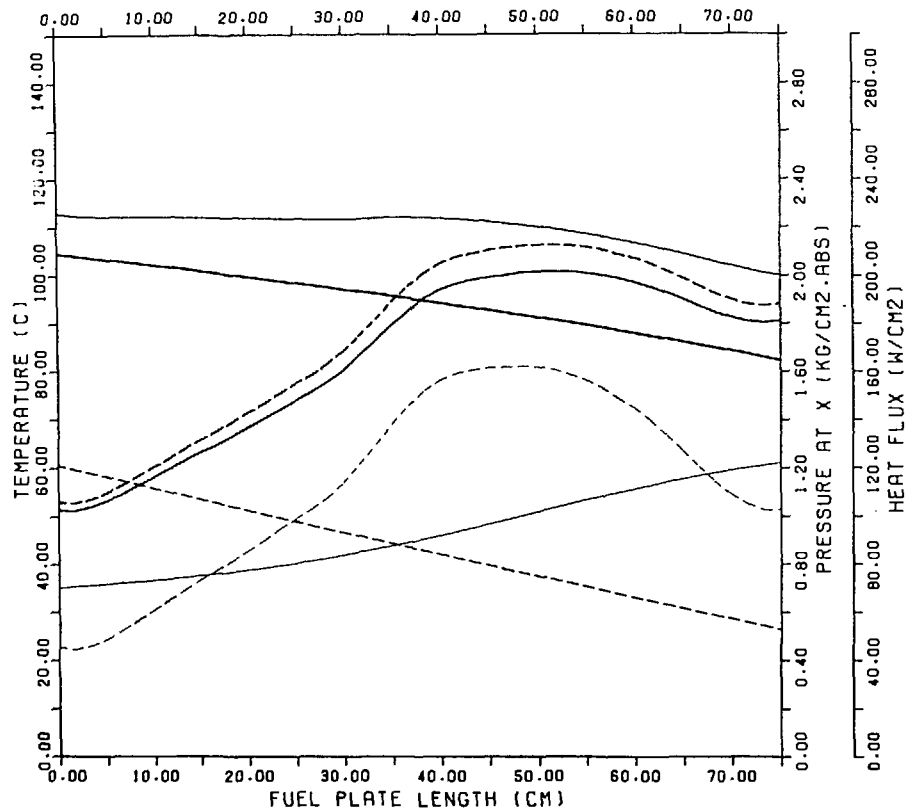

CASE NO. IA=1 JA=1 N=1 NP=1 K=1
STANDARD FUEL PLATE
— COOLANT TEMPERATURE
— CLAD SURFACE TEMPERATURE
- - - HEAT MAXIMUM TEMPERATURE
— SATURATION TEMPERATURE
— ONB TEMPERATURE
- - - PRESSURE AT X
- - - HEAT FLUX

FORCED CONVECTION (JRR3001)

2. Sample calculation result for natural convection

(1) Input data

COOLOD-N THERMAL HYDRAULIC CALCULATION

CALCULATION DATE 89-08-04 PAGE 1

```
*****
*** COOLOD-N THERMAL HYDRAULIC CALCULATION ( MODEL3 ; NATURAL FLOW ) ***
***          CALCULATION DATE      89-08-04          ***
***          INITIAL INPUT DATA          ***
*****
```

```
INPUT CARD B1      INFORM
                   1

INPUT CARD B2      IAHX      INAX      JHAXH      NMAX      NPLOT      KEY(1)      KEY(2)      KEY(3)
                   1         5         20         1         1         1         5         0

INPUT CARD C
  QRR      PFLOW      TIN      DT      JANX
CASE 1    0.200    40.000    35.000    0.0    1

INPUT CARD E1      H1      H2      H3      A      B      C      D      ITWC
                   4.000    0.0     0.0     0.0    0.0    0.0    0.0    1

INPUT CARD E2      FRATE      VIN      VOUT      PRESIN      RAHF
                   0.8073    0.0     0.0     1.5500    0.0

INPUT CARD F1      STANDARD FUEL

INPUT CARD F21     MPHX      NFUEL      MA      UDENST      POROTY      IDPHX      IDCHX      EAREA      FRATEN
                   1         26.0     1         2.200     0.057     1         1         30.500    1.000

INPUT CARD F3      FR      FCOOL      FFILM      FHFLX      FCLAD      FBOND      FMEAT
                   1.450    1.330    1.370    1.170    1.000    1.000    1.000

INPUT CARD F4      J      FZ      DDZ      ZET
                   1     0.8810    4.000    0.0
                   2     0.9430    4.000    0.0
                   3     1.0445    4.000    0.0
                   4     1.1785    4.000    0.0
                   5     1.2905    4.000    0.0
                   6     1.3695    4.000    0.0
                   7     1.4100    4.000    0.0
                   8     1.4190    4.000    0.0
                   9     1.4020    4.000    0.0
                  10     1.3635    4.000    0.0
                  11     1.2120    4.000    0.0
                  12     1.0225    4.000    0.0
                  13     0.9140    4.000    0.0
                  14     0.8210    4.000    0.0
                  15     0.7315    4.000    0.0
                  16     0.6420    4.000    0.0
                  17     0.5515    4.000    0.0
                  18     0.4640    4.000    0.0
                  19     0.4089    3.000    0.0
                  20     0.3891    3.000    0.0
```

INPUT CARD F51			INPUT CARD F52					INPUT CARD F53					
NP=	PLATE NAME		XPLATE	FLOCL	IDPL	KMI	IP101	IOU1		K	ICHL	MHEAT	FRATEC
1	STANDARD FUEL PLATE		20.0	1.510	1	1	1	1		1	1	2.0	1.0000

INPUT	CARD F6	IDP	XAI	XBI	XCI	YAI	HAI	HBI	HCI
		1	0.038	0.038	0.076	6.160	1.000	75.000	1.000

INPUT	CARD F76	IDC	XCHI	YCHI	MSFLW	MSFUEL	INPUT	CARD F77	IS	ZETA	DH	ZLAM	DE	AREA
		1	0.228	6.660	11	6								
							1		0.351	0.0	0.0	0.0	0.0	36.240
							2		0.0	31.800	64.000	6.070	0.0	36.240
							3		0.087	0.0	0.0	0.0	0.0	36.240
							4		0.0	2.200	64.000	7.150	0.0	51.400
							5		0.184	0.0	0.0	0.0	0.0	30.500
							6		0.0	77.000	96.000	0.441	0.0	30.500
							7		0.165	0.0	0.0	0.0	0.0	30.500
							8		0.0	3.650	64.000	7.150	0.0	51.400
							9		0.077	0.0	0.0	0.0	0.0	51.400
							10		0.0	59.800	64.000	18.400	0.0	71.060
							11		1.000	0.0	0.0	0.0	0.0	71.060

INPUT CARD <G1>	KVELO	JUHAX	JLMAX	IHTC	KBFLG	MCMAT	NAIIP
	1	5	5	4	0	2	0

CHANNEL FLOW NO.=	1	NUMBER OF MESH=	12	ZETA	DH	ZLAM	HOE	AR
1	5.0000E-01	0.0	0.0	0.0	0.0	0.0	5.657E+02	
2	0.0	7.3000E+00	9.6000E+01	6.0000E+00	0.0	0.0	5.6549E+02	
3	4.5000E-01	0.0	0.0	0.0	0.0	0.0	5.6270E+01	
4	0.0	5.0500E+01	9.6000E+01	6.0000E 01	0.0	0.0	5.6270E+01	
5	2.0300E-01	6.9000E+00	9.6000E+01	6.0000E 01	0.0	0.0	4.1340E+01	
6	0.0	8.5600E+01	9.6000E+01	6.0000E-01	0.0	0.0	5.6270E+01	
7	4.8600E-01	2.5000E+00	9.6000E+01	6.0000E-01	0.0	0.0	4.1340E+01	
8	0.0	2.5000E+00	9.6000E+01	2.0190E+00	0.0	0.0	1.0187E+02	
9	1.4500E-01	0.0	0.0	0.0	0.0	0.0	7.2350E+01	
10	0.0	1.2000E+01	9.6000E+01	6.9680E-01	0.0	0.0	7.2350E+01	
11	1.0000E+00	0.0	0.0	0.0	0.0	0.0	7.2350E+01	
12	0.0	8.0000E+00	9.6000E+01	6.0000E+00	0.0	0.0	8.7641E+02	

CHANNEL FLOW NO.=	2	NUMBER OF MESH=	4	ZETA	DH	ZLAM	HDE	AR
1	5.0000E-01	0.0	0.0	0.0	0.0	0.0	3.0480E+02	
2	2.8800E-01	0.0	0.0	0.0	0.0	0.0	3.0480E+02	
3	0.0	1.0000E+02	6.4000E+01	2.0000E+01	0.0	0.0	3.0480E+02	
4	1.0000E+00	0.0	0.0	0.0	0.0	0.0	3.0480E+02	

INPUT DATA FORMAT => COOLOD ORIGINAL

VELOCITY(+0) MASS FLOW RATE(+1)=> 1

UPPER PRENUM MESH= 5 FUEL PLATE MESH= 20 LOWER PRENUM MESH= 5

JMSH NN= 1 MSFLW= 11 NPMAX= 1 KMAX= 1 KEY(2)= 5
 1 1
 2 2
 3 3
 4 4
 5 5
 6 6
 7 7
 8 8
 9 9
 10 10
 11 11

JMSH NN= 2 MSFLW= 12 NPMAX= 1 KMAX= 1 KEY(2)= 5
 1 1
 2 2
 3 3
 4 4
 5 5
 6 6
 7 7
 8 8
 9 9
 10 10
 11 11
 12 12

JMSH NN= 3 MSFLW= 4 NPMAX= 1 KMAX= 1 KEY(2)= 5
 1 1
 2 2
 3 3
 4 4
 NN= 1 JFMAX= 11 JMSH= 1 2 3 4 5 6 7 8 9 10
 NN= 11 JFMAX=
 NN= 2 JFMAX= 0 JMSH=
 NN= 3 JFMAX= 0 JMSH=

CB GLIM
 1.400E-02 10.00

IOBG

1	2	3	4	5	6	7	8	9	10	11	12	13	14	15	16	17	18	19	20	21	22	23	24	25	
0	0	0	0	0	0	0	0	0	0	0	0	0	0	0	0	0	0	0	0	0	0	0	0	0	0
26	27	28	29	30	31	32	33	34	35	36	37	38	39	40	41	42	43	44	45	46	47	48	49	50	
0	0	0	0	0	0	0	0	0	0	0	0	0	0	0	0	0	0	0	0	0	0	0	0	0	

(2) Output

COOLOD N THERMAL HYDRAULIC CALCULATION CASE = (JA- 1 JA- 1)

CALCULATION DATE 89-08-04 PAGE 2

```
*****  
**  
** COOLOD-N THERMAL HYDRAULIC CALCULATION ( MODEL3 ; NATURAL FLOW ) **  
** RESULTS OF CALCULATION AND USED VALUES **  
**  
*****
```

```
*** REACTOR CORE ***  
REACTOR THERMAL POWER = 0.20 MW  
AREA OF TOTAL FULL CHANNELS = 793.00 CM2  
CORE FLOW RATE = 2.326 KG/S  
  
NUMBER OF FUEL ELEMENTS = 26.0 ELEMENTS  
  
STANDARD FUFL = 26.0 (ELEMENTS)  
AVERAGE HEAT GENERATION = 10.95 (W/CM3)  
AVERAGE MASS FLUX = 29.511 (KG/M2 SEC)
```

COOLANT TEMP. --(SEPARATED MODEL) KITE = 0

 ** STANDARD FUCL **

 AVERAGE CHANNEL TEMPERATURE DISTRIBUTION

FLOW CHANNEL AREA = 30.50 CM2
 NUMBER OF FUEL PLATLS
 STANDARD FUEL PLATE= 20.0

----- TEMPERATURE DISTRIBUTION -----

J	COOLANT (DEG.C)	CLADDING SURFACE (DEG.C)	CLADDING INNER (DEG.C)	FUEL HEAT OUTER (DEG.C)	FUEL HEAT MAXIMUM (DEG.C)
1	35.00	41.03	41.04	41.04	41.05
2	36.00	42.38	42.39	42.39	42.40
3	37.10	44.04	44.05	44.05	44.07
4	38.32	46.00	46.01	46.01	46.03
5	39.69	47.96	47.97	47.97	47.99
6	41.15	49.80	49.82	49.82	49.83
7	42.68	51.52	51.53	51.53	51.55
8	44.24	53.09	53.10	53.10	53.12
9	45.79	54.51	54.52	54.52	54.54
10	47.32	55.77	55.79	55.79	55.80
11	48.73	56.33	56.34	56.34	56.36
12	49.96	56.48	56.49	56.49	56.50
13	51.03	56.90	56.91	56.91	56.92
14	51.99	57.31	57.31	57.31	57.32
15	52.84	57.62	57.63	57.63	57.64
16	53.60	57.84	57.85	57.85	57.86
17	54.25	57.95	57.96	57.96	57.96
18	54.81	57.97	57.98	57.98	57.98
19	55.29	58.11	58.12	58.12	58.12
20	55.62	58.31	58.31	58.31	58.31

** HOT CHANNEL FACTORS (EXCEPT F2) **
 F(COOLANT)= 1.000 F(FILM)= 1.000 F(CLAD)= 1.000 F(BOND)= 1.000 F(HEAT)= 1.000

----- HEAT TRANSFER CONDITION -----

J	FZ	TRANSFER COEFFICIENT (W/CM2.C)	HEAT FLUX IN PLATE SURFACE		XAA (CM)	HEAT GENERATION (W/CM3)
			(W/CM2)	(KC/M2.HR)		
1	0.881	0.0608	0.367	0.31526E+04	0.038	9.649
2	0.943	0.0616	0.392	0.33745E+04	0.038	10.328
3	1.045	0.0626	0.435	0.37377E+04	0.038	11.440
4	1.179	0.0639	0.490	0.42172E+04	0.038	12.907
5	1.290	0.0649	0.537	0.46179E+04	0.038	14.134
6	1.370	0.0659	0.570	0.49006E+04	0.038	14.999
7	1.410	0.0664	0.587	0.50456E+04	0.038	15.443
8	1.419	0.0667	0.591	0.50778E+04	0.038	15.541
9	1.402	0.0670	0.583	0.50169E+04	0.038	15.355
10	1.363	0.0671	0.567	0.48792E+04	0.038	14.934
11	1.212	0.0664	0.504	0.43370E+04	0.038	13.274
12	1.023	0.0653	0.426	0.36589E+04	0.038	11.199
13	0.914	0.0648	0.380	0.32707E+04	0.038	10.010
14	0.821	0.0642	0.342	0.29379E+04	0.038	8.992
15	0.732	0.0636	0.304	0.26176E+04	0.038	8.012
16	0.642	0.0629	0.267	0.22973E+04	0.038	7.031
17	0.552	0.0620	0.230	0.19735E+04	0.038	6.040
18	0.464	0.0611	0.193	0.16604E+04	0.038	5.082
19	0.409	0.0603	0.170	0.14631E+04	0.038	4.478
20	0.389	0.0603	0.162	0.13925E+04	0.038	4.262

STANDARD FUEL PLATE (STANDARD FUEL)

CHANNEL DIMENSION = 0.228 = 6.660 (CM)
 CHANNEL VELOCITY = 3.00 (CM/SEC)

----- TEMPERATURE DISTRIBUTION -----

J	COOLANT (DEG.C)	CLADDING SURFACE (DEG.C)	CLADDING INNER (DEG.C)	FUEL MEAT OUTER (DEG.C)	FUEL MEAT MAXIMUM (DEG.C)
1	35.00	50.64	50.66	50.66	50.68
2	37.93	54.35	54.37	54.37	54.39
3	41.12	58.86	58.88	58.88	58.91
4	44.68	64.16	64.18	64.18	64.21
5	48.64	69.43	69.46	69.46	69.49
6	52.90	74.53	74.55	74.55	74.59
7	57.36	79.25	79.28	79.28	79.31
8	61.89	83.66	83.69	83.69	83.72
9	66.40	87.71	87.74	87.74	87.77
10	70.83	91.45	91.48	91.48	91.51
11	74.95	93.40	93.42	93.42	93.45
12	78.52	94.33	94.35	94.35	94.38
13	81.61	95.86	95.88	95.88	95.90
14	84.38	97.26	97.28	97.28	97.30
15	86.85	98.45	98.46	98.46	98.48
16	89.04	99.32	99.33	99.33	99.35
17	90.95	99.90	99.91	99.91	99.93
18	92.56	100.23	100.24	100.24	100.25
19	93.95	100.76	100.77	100.77	100.78
20	94.91	101.42	101.43	101.43	101.44

** HOT CHANNEL FACTORS (EXCEPT FZ) **

F(COOLANT)= 2.912 F(FILM)= 3.000 F(LAD)= 2.189 F(BOND)= 2.189 F(MEAT)= 2.189

----- HEAT TRANSFER CONDITION -----

J	FZ	TRANSFER COEFFICIENT (W/CM2.C)	HEAT FLUX IN PLATE SURFACE (W/CM2)	XAA (CM)	HEAT GENERATION (W/CM3)	
1	0.881	0.0703	1.100	0.94565E+04	0.038	28.943
2	0.943	0.0717	1.177	0.10122E+05	0.038	30.980
3	1.045	0.0735	1.304	0.11212E+05	0.038	34.315
4	1.179	0.0755	1.471	0.12650E+05	0.038	38.717
5	1.290	0.0775	1.611	0.13852E+05	0.038	42.397
6	1.370	0.0791	1.710	0.14700E+05	0.038	44.992
7	1.410	0.0804	1.760	0.15135E+05	0.038	46.323
8	1.419	0.0814	1.771	0.15231E+05	0.038	46.618
9	1.402	0.0822	1.750	0.15049E+05	0.038	46.060
10	1.363	0.0825	1.702	0.14636E+05	0.038	44.795
11	1.212	0.0820	1.513	0.13009E+05	0.038	39.818
12	1.023	0.0807	1.276	0.10975E+05	0.038	33.592
13	0.914	0.0801	1.141	0.98108E+04	0.038	30.028
14	0.821	0.0795	1.025	0.88125E+04	0.038	26.972
15	0.732	0.0788	0.913	0.78518E+04	0.038	24.032
16	0.642	0.0780	0.801	0.68911E+04	0.038	21.092
17	0.552	0.0769	0.688	0.59197E+04	0.038	18.118
18	0.464	0.0756	0.579	0.49805E+04	0.038	15.244
19	0.409	0.0749	0.510	0.43886E+04	0.038	13.432
20	0.389	0.0745	0.486	0.41770E+04	0.038	12.784

STANDARD FUEL PLATE (PRESSURE , ONB & ONB CONDITION)

		PRESSURE AT Z (KG/CM ² A)	PRESSURE LOSS (KG/CM ²)	TOTAL LOSS (KG/CM ²)	COOLANT VELOCITY (CM/SEC)	TSAT (C)	TONB (C)	TCLAD (C)	DONB	HEAT CLAD	FLUX (W/CM ²) QONB QDNB DNBR	DNB ID
I	INLET	PLENUM	1.550		0.0							
I	STRETCH(1)	INLET	1.550	0.00000	0.00000	2.48						
I	STRETCH(1)	OUT	1.550	0.0	0.00000	2.48						
I	STRETCH(2)	INLET	1.550	0.0	0.00000	2.48						
I	STRETCH(2)	OUT	1.518	0.00000	0.00000	2.48						
I	STRETCH(3)	INLET	1.518	0.00000	0.00000	2.48						
I	STRETCH(3)	OUT	1.518	0.0	0.00000	2.48						
I	STRETCH(4)	INLET	1.518	0.0	0.00000	1.75						
I	STRETCH(4)	OUT	1.516	0.00000	0.00000	1.75						
I	STRETCH(5)	INLET	1.516	0.00000	0.00000	2.95						
I	STRETCH(5)	OUT	1.516	0.0	0.00000	2.95						
I	PLATE	ENTRANCE	1.516	0.0	0.00000	2.95						
I	FUEL PLATE ZONE	1	1.515	0.00001	0.00001	2.95	111.09	112.42	50.64	61.77	0.94 = 0.0	15.97 17.00 1.0
I	FUEL PLATE ZONE	2	1.511	0.00002	0.00003	2.95	111.01	112.38	54.35	58.03	1.01 = 0.0	15.95 15.87 1.0
I	FUEL PLATE ZONE	3	1.507	0.00002	0.00005	2.96	110.93	112.37	58.86	53.52	1.11 = 0.0	15.94 14.31 1.0
I	FUEL PLATE ZONE	4	1.503	0.00002	0.00007	2.96	110.86	112.38	64.16	48.22	1.26 = 0.0	15.92 12.67 1.0
I	FUEL PLATE ZONE	5	1.499	0.00002	0.00008	2.97	110.78	112.37	69.43	42.94	1.38 = 0.0	15.90 11.56 1.0
I	FUEL PLATE ZONE	6	1.495	0.00002	0.00010	2.97	110.70	112.34	74.53	37.81	1.46 = 0.0	15.88 10.88 1.0
I	FUEL PLATE ZONE	7	1.491	0.00002	0.00011	2.98	110.62	112.28	79.25	33.03	1.50 = 0.0	15.86 10.55 1.0
I	FUEL PLATE ZONE	8	1.487	0.00002	0.00013	2.99	110.54	112.21	83.66	28.55	1.51 = 0.0	15.84 10.47 1.0
I	FUEL PLATE ZONE	9	1.483	0.00002	0.00014	2.99	110.46	112.17	87.71	24.42	1.49 = 0.0	15.81 10.58 1.0
I	FUEL PLATE ZONE	10	1.480	0.00002	0.00015	3.00	110.38	112.03	91.45	20.58	1.45 = 0.0	15.79 10.86 1.0
I	FUEL PLATE ZONE	11	1.476	0.00002	0.00016	3.01	110.30	111.86	93.40	18.46	1.29 = 0.0	15.77 12.20 1.0
I	FUEL PLATE ZONE	12	1.472	0.00002	0.00017	3.02	110.22	111.67	94.33	17.33	1.09 = 0.0	15.75 14.45 1.0
I	FUEL PLATE ZONE	13	1.468	0.00001	0.00018	3.02	110.14	111.51	95.86	15.65	0.97 = 0.0	15.73 14.14 1.0
I	FUEL PLATE ZONE	14	1.464	0.00001	0.00019	3.03	110.06	111.37	97.26	14.10	0.88 = 0.0	15.72 17.95 1.0
I	FUEL PLATE ZONE	15	1.460	0.00001	0.00021	3.03	109.98	111.22	98.45	12.78	0.78 = 0.0	15.70 20.33 1.0
I	FUEL PLATE ZONE	16	1.456	0.00001	0.00022	3.04	109.90	111.07	99.32	11.75	0.68 = 0.0	15.68 22.91 1.0
I	FUEL PLATE ZONE	17	1.452	0.00001	0.00023	3.04	109.82	110.91	99.90	11.01	0.59 = 0.0	15.67 26.64 1.0
I	FUEL PLATE ZONE	18	1.448	0.00001	0.00024	3.04	109.74	110.75	100.23	10.52	0.49 = 0.0	15.65 31.64 1.0
I	FUEL PLATE ZONE	19	1.444	0.00001	0.00025	3.05	109.66	110.61	100.76	9.85	0.44 = 0.0	15.64 35.87 1.0
I	FUEL PLATE ZONE	20	1.441	0.00001	0.00026	3.05	109.60	110.53	101.42	9.11	0.41 = 0.0	15.63 37.67 1.0
I	WORST CONDITION*		1.441				109.58	110.51			1.51 = 0.0	15.63 10.33 1.0
I	PLATE	EXIT	1.440	0.00000	0.00026	3.05						
I	STRETCH(6)	INLET	1.440	0.00000	0.00026	3.05						
I	STRETCH(6)	OUT	1.440	0.0	0.00026	3.05						
I	STRETCH(7)	INLET	1.440	0.0	0.00026	1.81						
I	STRETCH(7)	OUT	1.437	0.00000	0.00026	1.81						
I	STRETCH(8)	INLET	1.437	0.00000	0.00026	1.81						
I	STRETCH(8)	OUT	1.437	0.0	0.00026	1.81						
I	STRETCH(9)	INLET	1.437	0.0	0.00026	1.31						
I	STRETCH(9)	OUT	1.379	0.00000	0.00026	1.31						
I	STRETCH(10)	INLET	1.379	0.00000	0.00026	1.31						
I	STRETCH(10)	OUT	1.379	0.0	0.00026	1.31						
I	OUTLET	PLENUM	1.379	0.0	0.00026	0.0						

----- DNBI0=1 Q1=0.005*G**0.611 ---- DNBI0=2 Q2=(A/AN)(OH1/HFG)*G ---- DNBI0=3 Q3=0.7(A/AN)RT(W/R)/RT(1+(RG/RL)**0.25) ----

---- TCLAD < TSAT

HEAT FLUX OF CLAD --- Q=FR=FH=FL

(KARAN - NIKURAOSE EQUATION WAS USED FOR WALL LOSS CALCULATION)

-----PLOT INPUT DATA FROM FT05 -----4-----5-----6-----7--

WITHX	WITHY	TMIN	TMAX	PHIN	PMAX	HMIN	HMAX
150.000	200.000	0.0	150.000	0.0	2.000	0.0	200.000

NEWI= NEW

TITLE= NATURAL CONVECTION (MODEL3M1)

IDPLOT= 1	IDPLOT= 2	IDPLOT= 3	IDPLOT= 4	IDPLOT= 5	IDPLOT= 6	IDPLOT= 7
11	13	23	14	12	22	21
NSHBL = 1	NSHBL = 2	NSHBL = 3	NSHBL = 4	NSHBL = 5	NSHBL = 6	NSHBL = 7
0	0	0	0	0	0	0

-----PLOT INPUT DATA FROM FT11 -----4-----5-----6-----7--

JA= 1 JA= 1 N= 1 NP= 1 K= 1

J	X(J)	TCOOLANT	TCLAD	TMEAT	TSAT	TOND	PRESS	HEAT FLUX
1	0.0	35.00	50.64	50.68	111.09	112.42	1.51519	1.10
2	4.000	37.93	54.35	54.39	111.01	112.38	1.51120	1.18
3	8.000	41.12	58.86	58.91	110.93	112.37	1.50721	1.30
4	12.000	44.68	64.16	64.21	110.86	112.38	1.50323	1.47
5	16.000	48.64	69.43	69.49	110.78	112.37	1.49925	1.61
6	20.000	52.90	74.53	74.59	110.70	112.34	1.49529	1.71
7	24.000	57.36	79.25	79.31	110.62	112.28	1.49134	1.76
8	28.000	61.89	83.66	83.72	110.54	112.21	1.48739	1.77
9	32.000	66.40	87.71	87.77	110.46	112.12	1.48346	1.75
10	36.000	70.83	91.45	91.51	110.38	112.03	1.47954	1.70
11	40.000	74.95	93.40	93.45	110.30	111.86	1.47562	1.51
12	44.000	78.52	94.33	94.38	110.22	111.67	1.47171	1.28
13	48.000	81.61	95.86	95.90	110.14	111.51	1.46779	1.14
14	52.000	84.38	97.26	97.30	110.06	111.37	1.46388	1.02
15	56.000	86.85	98.45	98.48	109.98	111.22	1.45998	0.91
16	60.000	89.04	99.32	99.35	109.90	111.07	1.45607	0.80
17	64.000	90.95	99.90	99.93	109.82	110.91	1.45216	0.69
18	68.000	92.56	100.23	100.25	109.74	110.75	1.44825	0.58
19	72.000	93.95	100.76	100.78	109.66	110.61	1.44435	0.51
20	75.000	94.91	101.42	101.44	109.60	110.53	1.44141	0.49

PLOT START, JMAX3= 23

II = 1 PLOT END
 II = 2 PLOT END
 II = 3 PLOT END
 II = 4 PLOT END
 II = 5 PLOT END
 II = 6 PLOT END
 II = 7 PLOT END

NORMAL END

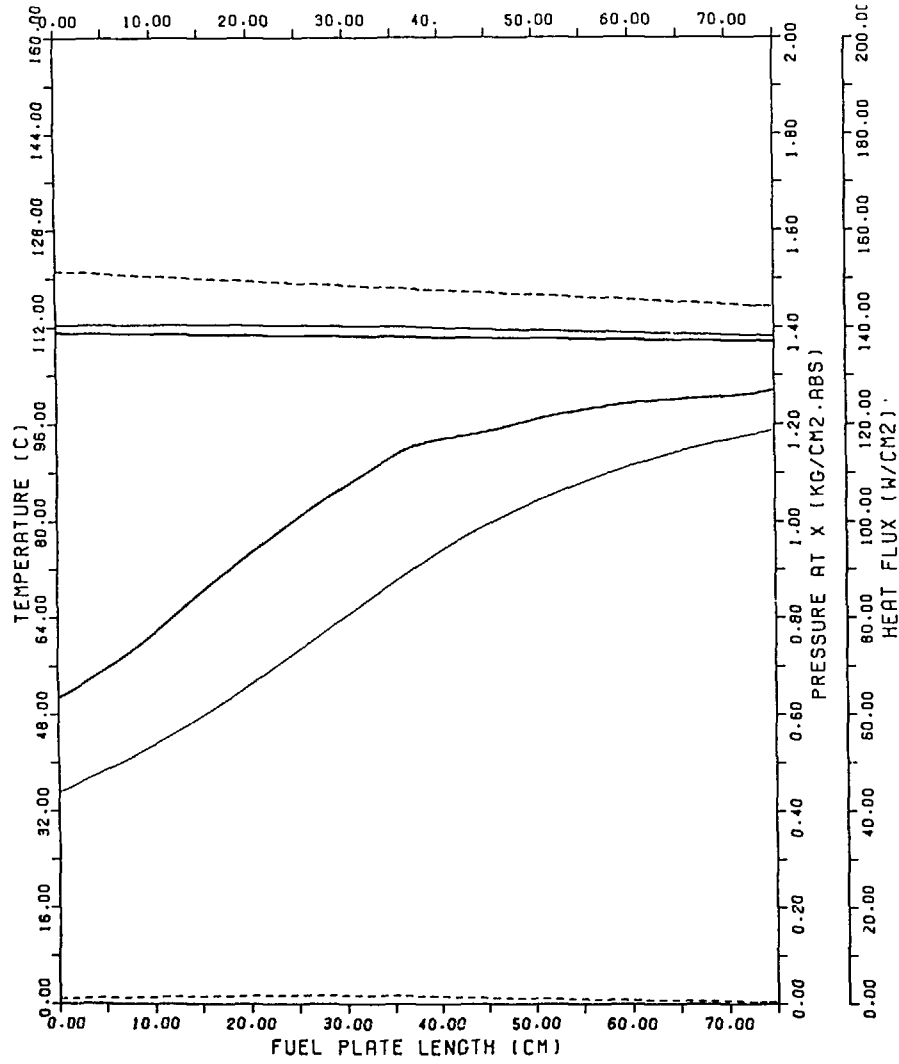

CASE NO. IA=1 JA=1 N=1 NP=1 K=1
STANDARD FUEL PLATE
— COOLANT TEMPERATURE
— CLAD SURFACE TEMPERATURE
- - - MEAT MAXIMUM TEMPERATURE
— SATURATION TEMPERATURE
— ONB TEMPRATURE
- - - PRESSURE AT X
- - - HEAT FLUX

NATURAL CONVECTION (MODEL3M)

Appendix C Sample JCL

(1) Sample 1 (Calculation and plot)

```

*****
000001 //JCLG JOB
000002 //JCLG EXEC JCLG
000003 //SYSIN DD DATA,DLM='++'
000004 // JUSER ****3907,MA.KAMINAGA,0515.05
000005     T.1 W.2 I.3 C.3 SORP GRP
000006     OPTP PASSWORD=***,MSGLEVEL=(1,1)
000007 //RUN EXEC LMGO,LM=3907.CLDN
000008 //FT05F001 DD DSN=J3907.JRR3CLDN.DATA(JRR3001),DISP=SHR
000009 // EXPAND DISK,DDN=FT11F001
000010 // EXPAND GRNLP
000011 ++
000012 //
*****

```

(2) Sample 2 (Calculation and no plot)

```

*****
000001 //JCLG JOB
000002 //JCLG EXEC JCLG
000003 //SYSIN DD DATA,DLM='++'
000004 // JUSER ****3907,MA.KAMINAGA,0515.05
000005     T.1 W.2 I.3 C.3 SORP
000006     OPTP PASSWORD=***,MSGLEVEL=(1,1)
000007 //RUN EXEC LMGO,LM=3907.CLDN
000008 //FT05F001 DD DSN=J3907.JRR3CLDN.DATA(JRR3001),DISP=SHR
000009 //FT11F001 DD DUMMY
000010 ++
000011 //
*****

```

(3) Sample 3 (Calculation and plot)

```

*****
000001 //JCLG JOB
000002 //JCLG EXEC JCLG
000003 //SYSIN DD DATA,DLM='++'
000004 // JUSER ****3907,MA.KAMINAGA,0515.05
000005     T.1 W.2 I.3 C.3 SORP GRP
000006     OPTP PASSWORD=***,MSGLEVEL=(1,1)
000007 //FORT EXEC FORT77,SO='J3907.CLDN',Q='.FORT77',LCT=62,
000008 //           A='ELM(*)',
000009 //           B='NOSOURCE,LC(62) '
000010 //LKED EXEC LKED77
000011 //SYSLIB DD DSN=SYS9.PNL.LOAD,DISP=SHR
000012 //RUN EXEC GO
000013 //FT05F001 DD DSN=J3907.JRR3CLDN.DATA(JRR3001),DISP=SHR
000014 // EXPAND DISK,DDN=FT11F001
000015 // EXPAND GRNLP
000016 ++
000017 //
*****

```

(4) Sample 4 (Calculation and no plot)

```

*****
000001 //JCLG JOB
000002 //JCLG EXEC JCLG
000003 //SYSIN DD DATA,DLM='++'
000004 // JUSER ****3907,MA.KAMINAGA,0515.05
000005     T.1 W.2 I.3 C.3 SORP
000006     OPTP PASSWORD=***,MSGLEVEL=(1,1)
000007 //FORT EXEC FORT77,SO='J3907.CLDN',Q='.FORT77',LCT=62,
000008 //           A='ELM(*)',
000009 //           B='NOSOURCE,LC(62) '
000010 //LKED EXEC LKED77
000011 //SYSLIB DD DSN=SYS9.PNL.LOAD,DISP=SHR
000012 //RUN EXEC GO
000013 //FT05F001 DD DSN=J3907.JRR3CLDN.DATA(JRR3001),DISP=SHR
000014 //FT11F001 DD DUMMY
000015 ++
000016 //
*****

```