

MICROCOPY RESOLUTION TEST CHART
 NATIONAL BUREAU OF STANDARDS
 STANDARD REFERENCE MATERIAL 1010a
 (ANSI and ISO TEST CHART No. 2)

Laboratori Nazionali di Frascati

ITB100004

INFN - LNF-91/005 (IR)
21 Gennaio 1991

G. Anzivino, G. Bari, S. Bianco, G. Bruni, G. Cara Romeo, R. Casaccia, K. Chen, F. Cindolo, A. Contin, X. Cui, G. D'Ali, L. Daniello, C. Del Papa, M. De Felici, M. Enorini, D. Fabbri, F.L. Fabbri, B. Gao, M. Giardoni, G. Iacobucci, C. Jing, I. Laakso, Y. Li, M. Lindozzi, G. Maccarone, F. Masi, D. Mencarini, R. Nania, E. Pallante, L. Passamonti, N.I. Qazi, S. Qian, V. Russo, G. Sartorelli, S. Sarwar, L. Terminiello, M. Ventura, L. Votano, A. Zallo:

LIMITED STREAMER CHAMBER TESTING AND QUALITY EVALUATION IN ASTRA

Presented at
4th Topical Seminar on Experimental Apparatus for High Energy Particle Physics and Astrophysics
San. Miniato (1990)

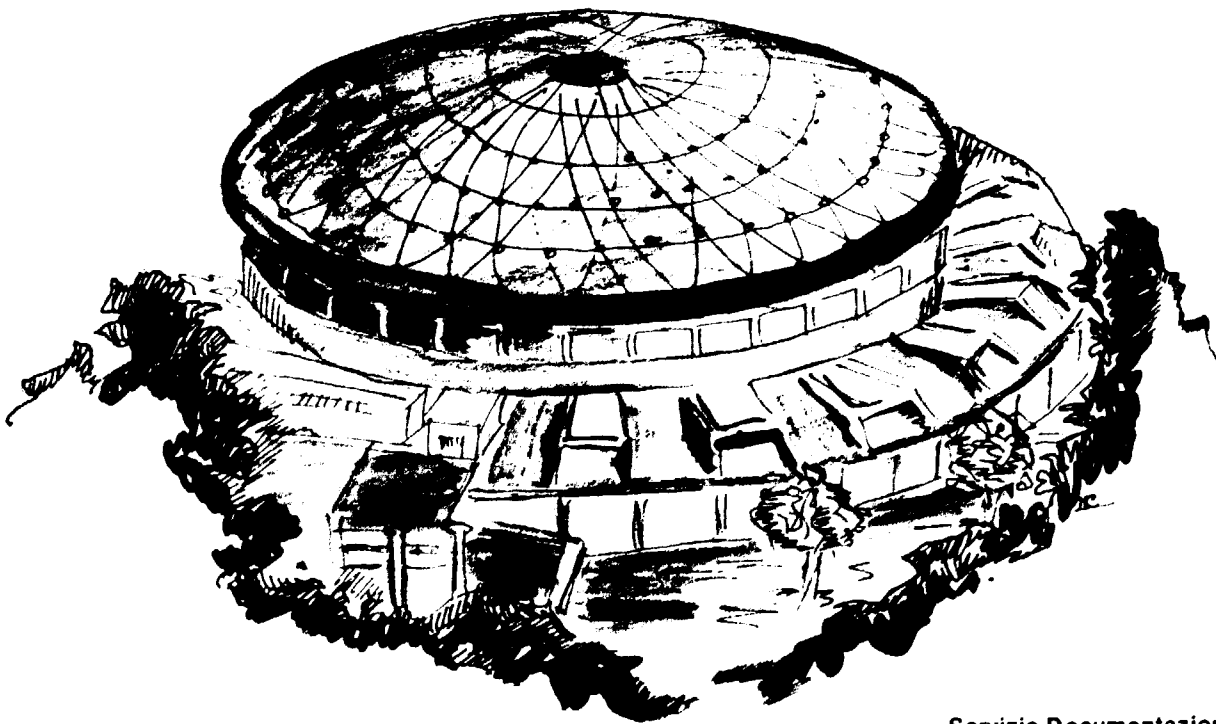

Servizio Documentazione
dei Laboratori Nazionali di Frascati
P.O. Box, 13 - 00044 Frascati (Italy)

**LIMITED STREAMER CHAMBER TESTING AND QUALITY EVALUATION
IN ASTRA**

G. Bari, G. Bruni, G. Cara Romeo, A. Contin, C. Del Papa, G. Iacobucci, G. Maccarone,
D. Mencarini, R. Nania and G. Sartorelli
University of Bologna and INFN, Bologna, Italy

G. Anzivino, S. Bianco, R. Casaccia, F. Cindolo, L. Daniello, M. De Felici, M. Enorini,
D. Fabbri, F. L. Fabbri, M. Giardoni, I. Laakso, M. Lindozzi, F. Masi, E. Pallante,
L. Passamonti, S. Qian, V. Russo, M. Ventura, L. Votano and A. Zallo
Laboratori Nazionali di Frascati del' INFN, C.P 13, 00044 Frascati (Rome), Italy

K. Chen, X. Cui, B. Gao, C. Jing, Y. Li, N.I. Qazi, S. Sarwar and L. Terminiello
ICSC World Laboratory, Lausanne, Switzerland

G. D'Ali
University of Palermo, Italy

Limited streamer chambers are extensively used for high-energy and nuclear physics experiments in accelerator and underground laboratories. The tracking system of LVD, an underground experiment to study muons and neutrino astronomy, will use roughly 15,000 limited streamer chambers and 100,000 external pickup strips with digital readout electronics. In this article we discuss the different aspects of chamber operation that serve to establish a testing procedure and to define acceptance criteria for selecting reliable and long-life devices. The procedures and the results obtained from a long-term test to evaluate streamer chamber quality, based upon a sample of 2900 items, are described. The selection tests and the long-term observations have been performed in the Astra laboratory, established at the *Laboratori Nazionali di Frascati* to carry out quality control procedures for streamer chambers on a large scale and in a controlled environment.

1.- INTRODUCTION

The Large Volume Detector¹ (LVD) is being installed in the Italian underground laboratory at Gran Sasso² under a cosmic ray shield of 3,600 mwe. The apparatus design is optimized to detect μ -mesons and determine their direction of flight, to detect low-energy neutrino interactions taking place within its volume and measure their interaction energies. The experiment is mainly aimed at studying neutrino bursts from stellar collapses, solar neutrino emission, astrophysical point-like sources of gammas and neutrinos, neutrino oscillations, monopoles and proton decay. The detector consists of 1,800 tons of liquid scintillator and roughly 15,000 limited streamer chambers. The scintillator system uses 190 identical "porta tanks" (6 m long, 2.2 m wide and 1.5 m high), each one housing eight scintillator counters [Fig. 1]. The tracking system is formed of L-shaped tracking segments, whose sides contain two layers of staggered streamer chambers placed along its length. Each layer of the chambers is sandwiched by 4 cm wide aluminum pickup strips placed parallel and perpendicular to the chamber wires [Fig. 2]. One side and the bottom of each porta tank is covered by a tracking segment to form a basic module for the detector [Fig. 3]. The 190 modules will be placed in a 40 m long, 12 m wide and 13 m high mechanical support structure located in Hall A of the Gran Sasso laboratory [Fig. 4].

2. - LIMITED STREAMER CHAMBERS FOR LVD TRACKING SYSTEM

The "limited streamer" regime is characterized by very high gain with an anode pulse charge of about 30 pC and a reduced dead time obtained by using an appropriate quencher in the gas mixture to stop the growth of a streamer. The limited streamer regime was first studied by Charpak et al.³ and Fisher et al.⁴, while the pioneering work of developing the limited streamer tubes (LST) for high-energy and nuclear physics was carried out at Frascati laboratory⁵. Plastic streamer chambers with a low resistivity graphite-coated cathode for external strip and pad readout, have become popular in applications of large-size tracking systems because they are easy to construct, simple to use and reliable. About a million LST chambers, based on Frascati production standards, are presently being used both in high-energy and nuclear physics in accelerator and underground experiments.

Despite the large demand for streamer chambers, there is very little industrial production of the finished product. While plastic profiles and sleeves are industrially produced, the coating, wiring and remaining fabrication is usually done by the user groups. Two production lines are being used to manufacture the large number of chambers needed to equip the LVD experiment; one at *Laboratori Nazionali di Frascati del' INFN*, and the second at Houston University. LVD streamer chambers [Fig. 5] have the conventional "Frascati" design: they are formed of a 6.3 m long PVC profile containing eight U-shaped cells. Each cell has a 1 cm x 1 cm cross section and its internal walls are resistive coated with conducting graphite paint. A Cu-Be 100- μ m wire is extended through the centre of each cell and connected to printed circuit boards at the two ends. The wires are supported by plastic bridges placed one meter apart throughout the length of the chamber in order to maintain them in the geometrical centre of the cell. The coated profile is inserted in a plastic jacket and end-caps are welded to both sides to achieve a gas-tight arrangement. The end-caps also provide the electrical and gas connections for each chamber.

One of the major concerns in the use of plastic streamer chambers for LVD is their reliability in time, especially in view of the fact that the operating period of LVD is planned to cover a few decades and the replacement of malfunctioning chambers is practically impossible

after their installation. Hence, the testing procedures and the acceptance criteria to guarantee a specified operation and a long lifetime for the devices are primary factors. In order to approach ideal zero-defect control, the necessity of selecting good quality chambers has been faced by many experimental groups. However, the testing methods and the selection criteria differ greatly and there are no well-established standards⁶. Claimed rejection Figures, including those due to production-line control and postproduction quality selection, reach 50%. After being selected, the chambers are reported to be very stable and long-life devices. Although the specific selection procedures vary from group to group, some common phases can be identified:

i)- Quality control during production

This is primarily achieved by controlling the resistivity of profile graphite coating. In fact, when chambers are to be used with strip or pad readout, a transparent cathode is required and the uniformity of graphite resistivity becomes a major factor⁷. Control during painting of the cathode is generally based on a feedback by measuring cathode resistivity of newly painted profiles and on visual observation by the operator to detect nonuniformities and white spots. Before wiring, cathode resistivity is measured once again using acceptance windows of a few hundred $K\Omega/sqr$ to a few $M\Omega/sqr$, varying from group to group. The declared rejection percentage for unacceptable cathode resistivity and other defects detected by visual observation, e.g., cold soldering of filament, poor end-cap welding and white spots on the cathode, are between 20% and 30%.

ii)- Search for leakages

Leak detection tests are performed by all user groups at the end of chamber manufacturing. In addition, many groups reconsider this problem at different phases of the chamber-testing procedures. The methods used are generally based on hermeticity tests, whose sensitivity and acceptance criteria are not easily comparable.

iii)-Conditioning

At this phase, the voltage applied to the finished chambers, filled with the appropriate gas mixture⁸, is increased in small steps to a few hundred volts above the expected knee voltage of the singles rate plateau. Limiting the supply current to an upper value of a few μA , the chambers are switched off and on as often as they draw the limiting value of current. Chambers reaching the final voltage are maintained at this level for some hours and passed on to the next phase of the selection procedures if they remain stable within the limiting current value. Roughly 10% of the chambers, with variations from group to group, are rejected during this phase.

iv)- Acceptance test

The chambers that pass the conditioning step are then put under observation, generally for a few days, with the aim of selecting reliable devices. This is the phase where methods and selection criteria differ more widely from group to group⁹⁻¹³. Average and maximum current, current bursts, plateau using cosmic rays, and observation of hysteric current after brief exposure to high-intensity source radiation are considered as selection parameters at this stage.

3. - ASTRA FACILITY

To face the problem of LVD streamer chamber quality control, we decided to make an intensive study of the aspects of chamber performance that could affect their long-term reliability and successful operation. Particularly due to the necessity for long lasting chambers, we decided to extend the usual conditioning phase (up to 2 days) and acceptance test procedures (up to 4 weeks). The quality selection tests were performed at the Frascati Astra laboratory that, set up for this purpose, is equipped with the instruments necessary for R&D investigations on related aspects of chamber operation and allows simultaneous tests for up to 1000 chambers.

In Astra, a multi-layer rigid steel structure is used to support the chambers and keep them in horizontal positions. Each layer has four sub-layers [Fig. 6] with a capacity of 25 chambers per sub-layer. The gas inputs of 100 chambers of one layer are connected in parallel to a steel container that serves as a gas distributor; the outputs are sent to another container that acts as an accumulator. The gas distributors of all the layers are connected in parallel to a mixture reservoir. A safety valve, provided for each layer, opens an emergency gas exit as the layer overpressure reaches 20 millibars. Since the chambers present a negligibly small impedance to gas flow, even small variations of the connection impedances can cause a variable flow rate through parallel connected chambers. A homogeneous flow is achieved by inserting an impedance in series with each chamber, realized by a steel cylinder having a helicoil groove, in the plastic tube that connects each chamber to the exit gas accumulator [Fig. 7]. The gas distribution scheme gives an internal mixture overpressure of 5 millibars at a flow rate of 1 volume/day and a self-compensation for small gas leaks, i.e, a chamber with a higher leakage is provided with a correspondingly higher flux. The Astra laboratory is equipped to provide binary and ternary gas mixtures (isobutane/argon or isobutane/argon and a third gas such as carbon dioxide). The source gases are housed outside the laboratory in a dual ramp system that automatically commutes from an empty ramp to a filled one. Each ramp consists of 4 cylinders. The gas mixture is formed in a metallic reservoir and the flow rate of the incoming component gases is measured by Hi-tech mass flowmeters, which provide the feedback to mass flow regulators. The system has an accuracy of 1% with a maximum output capacity of 1000 litres/hour. The mixture composition and impurities are monitored regularly at the input and output of the layers by Carlo Erba's Vega series gas chromatograph. Flux integrators are inserted in the input and output of each layer distribution line to monitor any anomalous leaks which could occur during the test. The laboratory has a comprehensive control of ambient conditions and maintains its temperature and humidity within preset limits (22°-24°C and humidity < 60%). It also has an appropriate safety system, as required to work with inflammable gas mixtures containing high hydrocarbon percentages. The safety system consists of hydrocarbon and fire detectors linked to a central control panel. The same panel also controls the rate of the blowing pump that captures the laboratory air at floor level and expels it. A moderate air exchange rate of one laboratory volume in 26 minutes is maintained in normal conditions; but in the case of a leak being detected with the isobutane percentage in the air reaching a level of 35% of the explosion limit, alarms are activated and the air exchange rate is increased to one volume in 15 minutes. High voltage to the chambers is provided by programmable CAEN SY127 power supplies. A distribution panel [Fig. 8] with current limiting resistors is used between the voltage supply and the chambers. The system is capable of providing a separate supply line for every chamber with a current resolution of 100 nA. The serial control inputs of all the voltage crates are chained together and interfaced to a Mac II computer via a Camac crate. High voltage system monitoring and control is carried out by a flexible online software.

4. - QUALITY EVALUATION FOR THE LVD CHAMBERS

General production-line controls were used for the LVD chambers. The graphite-coated PVC profiles were checked for cathode surface resistivity using an acceptance range of $500\text{K}\Omega/\text{sqr}$ to $3\text{M}\Omega/\text{sqr}$ just after painting and an acceptance range of $200\text{K}\Omega/\text{sqr}$ to $3\text{M}\Omega/\text{sqr}$ before anode wiring. The measurement was carried out using a resistivity probe at 5-6 points of each profile: the resistivity of each cell was required to be within the specified range at all the test points. Because of resistivity selection and other visible mechanical faults, 21% profiles were rejected at this stage.

The following procedures were followed for the post production selection tests performed at Astra. In all these tests, a gas mixture of 70% isobutane and 30% argon was used.

4.1 - Chamber gas leakage

Gas leakage is one of the important chamber characteristics to be controlled for stable operation and environmental safety, as an inflammable gas mixture is normally used. All users of the LST chambers claim inspection for leakages. Different methods have been reported, based on the hermeticity observations, such as water immersion⁸ and vacuum retention¹⁴. The real sensitivity of these methods is not clear and the levels of selection of the different groups are not easy to compare. Only a few groups performed the tests by measuring the incoming and outgoing flux¹⁵. Leaks must be minimized to prevent the loss of mixture and also to prevent the atmospheric impurities from entering the chambers. As our chambers were continuously washed by a fresh mixture (1 volume in 2 days), a dynamic impurity level of 1% by volume was established. In a dedicated test we observed that the chambers operate correctly for months, once washed and well sealed¹⁶. Although the atmospheric impurities intrude at a small enough rate, a continuous gas flow is practically needed in order to refill the lost gas mixture. A closed recirculating gas system is foreseen for the LVD experiment, with a refilling capacity of 1-2% by volume per day and a purification capacity of a few hundred ppm per day¹⁷. The gas system is expected to ensure an autonomy of several months, while maintaining the impurity content at less than the dynamic level of 1% by volume. Taking into account the above-mentioned requirements, our chambers must have less than 1% gas leakage per day in the operational conditions of 1 volume being recirculated in 2 days at an internal overpressure of 5-8 millibars.

For leakage measurement we used the hermeticity method. The chambers were washed and pressurized to 30 millibars by using a mixture of 70% isobutane and 30% argon. They were then closed and the subsequent drop of their overpressure observed. The reasons for this choice, the detailed procedure and the correspondence between the observed chamber leakage and the intrusion values expected in the given flow conditions will be described in a forthcoming article. In the same article we demonstrate that, due to the material deformation of pressurized chambers, a measurement at a level of 1% leakage per day sensitivity is time demanding. To reach this sensitivity, the pressurized chambers have to be observed for roughly 3 days in order to overcome the delayed strain of the material [Fig. 9]. Our experience has shown that transportation and handling can deteriorate the tightness properties of a chamber, mostly causing damage to end-cap thermal soldering. We therefore divided the leakage control in two parts. The decisive leakage measurement at a high sensitivity level was made at the last stage of the selection procedures, just before insertion of the chambers into the tracking segments, when there is little residual handling left. However, before this final leakage selection, two medium sensitivity tests were performed in Astra with the aim of identifying large leaks that could otherwise impair the tests under way. As a precaution, the end-cap

junctions of all the chambers were treated with a coat of "Plastivel", a plasticizing sealant from Markservices, before their leakage was measured. The treated chambers were washed with the gas mixture (70% isobutane and 30% argon) and pressurized to 30 millibars. The drop of overpressure for closed chambers was observed for one day. Chambers with a leakage greater than 5% per day were inspected, repaired and retested until they reached this level of acceptable leaks. After the chambers had been tested individually, they were placed in the layers and the gas connections were made. Another short test was performed to reveal any major leaks within a layer because of some faulty gas connection. During this test, the layers were filled with the mixture and the drop of overpressure from 20 millibars was observed for a full day. If a layer with a leakage greater than 5% per day was found, the fault was identified, removed and the test was repeated. Before starting the electrical tests, the impurity content of the chambers was brought to less than 1% by volume. For the rest of the test, a continuous mixture flow of 1 volume per 48 hours was used to eliminate intruded impurities and to wash out polymer products. The mixture composition and impurities were monitored regularly at input and output of the layers and gas impurities were kept within 1% by volume. The final leakage selection, before insertion of the LST's in the tracking segments, was done at 1% volume leakage per day. The percentage of chambers to be repaired at this stage was 1.6%. Only 0.3% of the chambers surviving up to this stage could not be repaired.

4.2 - Conditioning

In Fig. 10 we show the conditioning scheme followed for the first two days of the electrical test. The data acquisition system read the chamber current and its voltage every 30 seconds. Chambers were not allowed to draw more than 5 μA of current. When a chamber started to draw this maximum value of current, the channel voltage was reduced in such a way that the supply acted as a constant current source. A "trip" condition was recognized if a chamber continuously drew the maximum current for more than "trip time" of 10 seconds. If a trip occurred, the chamber voltage was reduced to zero, it remained off for 2.5 minutes (rest time), and was then brought up to one voltage step lower than the step at which it had shown the trip condition. All voltage transitions were made with a ramp up of 50 volts/s and a ramp down of 500 volts/s. Conditioning was continued for two days and if a chamber did not reach the final step, it was considered as a conditioning failure and removed from the test. During the early phase of the tests, the conditioning was done with slightly different parameters.

For the total of 2912 chambers, we found a failure rate of 4.4 %. The rejected chambers were opened and inspected to investigate the origin of their failure. Table I shows how the conditioning failures are further distributed.

Table I - Conditioning failures (4.4 % of total).

Failure reason	Percentage
Displaced wire	51%
Short circuits	19%
Discharge near plastic bridges	8%
Unknown causes	22%

The major origin of the failures was the displaced anode wire. Some of these cases also demonstrated burning deposits on anode wire produced by electric discharge.

Roughly one fifth of the failures when inspected showed a short circuiting characterized by a low DC resistance between filament and cathode. Such chambers usually start to draw

limiting current at a few hundreds of volts. Short circuiting was mostly caused by a failure of wire soldering in the plastic bridges. Wires were found uprooted from their soldered position and touching the cathode walls. Only a negligible percentage of chambers with short circuit showed broken wires.

In 8% of the failure inspections, signs of graphite abrasion and burning deposits were found on the anode wires near the plastic bridges. The effect was correlated to the use of a comb for aligning plastic bridges during chamber production. As the aligning procedure was later modified, this pathology was significantly reduced.

For roughly one fifth of the failed chambers, we were unable to identify a clear cause of malfunctioning and few of them were eventually recovered when closed and retested.

4.3 - Long duration acceptance test

Considering the stringent quality requirements of LVD, we decided that the long-term test had to be a standard procedure and a severe quality selection occasion for our chambers. All the chambers accepted after the conditioning phase were kept at 4900 volts for a period which typically lasted for more than four weeks. During that period, each chamber was individually powered by a single high voltage channel, and its current and voltage monitored every 30 seconds. The chamber voltage was always kept on, except for an occasional power failure, and all the remaining control logic of the conditioning phase was still followed.

In addition to the above procedures, samples of chambers under test were studied for other possible quality characteristics, such as single rate plateau, length and knee voltage of the plateau, and afterpulse probability.

Our chambers are to be operated in the limited streamer mode and are required to exhibit a stable, long and efficient singles rate plateau. At the beginning of our experience, the plateau measurement was carried out during the long-term observations, for all the chambers under test. A low discriminator threshold of $-8 \text{ mV}/50\Omega$ was used to make the knee voltage a true representation of transition between the proportional and the streamer regimes. Initially the procedure was used for roughly 600 chambers. However, as the probability that chambers having good current behaviour would not show an acceptable plateau, was found to be very little ($< 2\%$ of the selected chambers), the measurement was postponed until the end of the selection procedures.

Afterpulse observations were made on chambers showing anomalous current behaviour or an unacceptable singles count rate plateau. Afterpulses are the streamers which are produced by cathode-emitted electrons generated when ultraviolet photons or positive ions from a steamer hit the cathode material. Specific delay times from the parent steamer pulse characterize the two generation modes. These delay times, roughly 100 ns for photon-originated afterpulses and about 100 μs when ion originated, are the typical drift times for electrons and ions. No clear correlation was found between afterpulse generation and anomalous behaviour of the chamber current. A detailed study of the afterpulse probability as a function of different gas mixtures and their composition has been carried out and is reported in another paper¹⁶.

Chromatographic measurements of chamber gas were made to ensure the desired purity level. The measurements were used as a routine procedure after the initial washing of the chambers and whenever anomalous current behaviour (sudden increase of average current on one or more layers, etc.) was observed. Figure 11 shows a typical chromatogram obtained during electrical selection tests. The regular mixture composition control was very important to rapidly recognize and neutralize operator mistakes or apparatus bugs, which could otherwise

result in false chamber failures. We found that the new isobutane cylinders occasionally contained trapped air at their top, which may cause variations in the electrical characteristics of the chambers [Fig 12]. It was also observed that the chamber plateau is very sensitive to gas impurity, whereas the current is a relatively rigid parameter.

As already mentioned, the basic quality evaluation procedure for selecting reliable chambers has been based on average current and current bursts. The current expected to be drawn by a chamber, under a cosmic and local radioactivity environment, is of the order of a few tens of nA. However, many causes, such as surface current leakages, dust particles inside chambers and anode wire instabilities, are the major origins of higher or instable chamber currents. Sporadic bursts of current (spikes) that do not have a well-understood origin were observed for almost all the chambers, even for those which otherwise had a low and stable average current. If the voltage generator is not current limited, the current spikes can have a magnitude of hundreds of μA and can last up to a few minutes, as we observed in a dedicated test. If uncontrolled, they can cause permanent damage to the device. Spike protection is realized by limiting the voltage source to a maximum current value. As a chamber starts to draw a high current, its anode voltage is reduced by the ohmic drop across the current limiting resistor. The voltage is further reduced as the current reaches the maximum allowed value and the supply begins to act as a constant current source. Finally, if the overcurrent state persists longer than the trip time, the chamber is rescued by being switched off for the set rest time. During all these phases, the anode voltage decreases largely from the preset working point and the chamber loses its ability to serve as a detector. The efficiency of a chamber is determined by measuring the time for which its voltage can be kept on, without any current limiting action. This time, expressed as a percentage of the total time of observation, is defined as service time efficiency.

The choice of maximum current limit, trip time and rest time is crucial and it is a compromise between various considerations. While the set value of the maximum current limit determines the ohmic drop of the voltage before a pathology is recognized by the system, trip and rest time have a significant effect on safety protection of the chambers at the cost of their service time efficiency. The trip time and the maximum current limit have to be small enough for long-lasting and high magnitude spikes not to cause permanent damage to the chamber. They should also be small enough to prevent the chamber from working with an anode voltage that is too low compared to the preset working point, without any action from the monitoring system. Moreover, the values have to be large enough to tolerate the small variations in average current and not to invoke any unnecessary current limiting action of the supply. Our experience shows that the spikes that last for more than 5 seconds have little chance of extinguishing themselves. Correspondingly, we used a trip time of 10 seconds. The subsequent rest time was set to 2.5 minutes, which is a reasonable estimate for the interval during which the high voltage control system of LVD apparatus will be able to scan all the channels. The choice of maximum current limit is a little more delicate and it was selected with the aim of providing the same chamber electrical conditions during the test as in actual LVD operation. The minimum plateau length of the selected chambers is 500 volts. However, the working point voltage cannot be set too high since the multiplicity of the induced pulses, on the strips perpendicular to chamber wires, strongly depends upon the anode voltage [Fig. 13]. We also have to consider the dispersion of the knee voltage for different chambers (± 50 volts) and its variation for the same chamber with changes in temperature and pressure (± 50 volts). An operating voltage of 150 volts above the average knee of the plateau is considered to be reasonable, which leaves us with a safety margin of 50 volts to be sure that all the chambers will remain in the limited streamer

mode. Each μA of chamber current results in a voltage drop of 10 volts across the $10\text{M}\Omega$ current limiting resistor that is inserted before each anode wire. During the experiment, one high voltage channel will be connected to a group of 10-20 chambers in parallel. The maximum current limit will be set approximately $5\ \mu\text{A}$. This means that a voltage drop of up to 50 volts across the current limiting resistor is ignored before an overcurrent state is recognized. We also observe that service time inefficiency caused by one of the chambers in a group will be shared by all the chambers connected to the same channel. For the long-term test in Astra, values of $15\ \mu\text{A}$ and $10\ \mu\text{A}$ were used for earlier tests as the maximum current limit but most of the chambers were tested with the maximum current limit of $5\ \mu\text{A}$.

5. - CHAMBER CHARACTERISTICS

The behaviour of the chambers as observed in the long-term test is described in this chapter. Four weeks of observations give an integrated history graph for every chamber revealing its performance characteristics. Fig. 14 shows history graphs for some typical chambers and identifies the devices with stable low current [Fig. 14a], stable high current [Fig. 14b] and erratic behaviour [Fig. 14c]. In Fig. 15 we show the distributions of average current, standard deviation of current and service time efficiency for the first week. The average current distribution is peaked at about $120\ \text{nA}$ and nearly 86% of the chambers fall below $300\ \text{nA}$. The service time efficiency distribution shows that about 82% of the devices fall above 98% STE. The correlation between these quantities is shown in Fig. 16. We observe that a higher standard deviation of current is usually accompanied by a higher average current. The evolution trend in chamber average current during four weeks of the test is shown in Fig. 17a, where we plot the weekly average current correlations. We observe that many chambers have a decreasing current from the first to the second week, while for the following three weeks the majority of them shows an almost stable current. A similar improvement trend is observed for chamber service time efficiency [Fig. 17b]. These Figures indicate that the first week of the test is marked by a significant improvement in the performance of the chambers. The same trend is observed if we consider average current and service time efficiency, for different weeks, averaged over all the chambers [Table II].

Table II - Weekly average current and average service time efficiency.

Week no	Average current	Average service time efficiency
1	363 nA	92.5%
2	281 nA	96.8%
3	275 nA	96.9%
4	272 nA	96.9%

6. - SELECTION CRITERIA

The first quality evaluation was based on chamber service time efficiency. In Figure 18 we present a typical probability density graph for service time efficiency for the first week of observations. It shows that the chambers are divided in two groups, which begin to overlap at a point that roughly corresponds to 97% service time efficiency. A "cut" placed at 95-97% could be an efficient division boundary between the two different populations of the chambers.

However, we have to confirm that the chosen boundary really identifies two different quality classes, after observing the behaviour of the two populations separated by this cut in the following weeks. Hence, we divide the chambers with service time efficiency greater than 97% from those with service time efficiency less than 90% on the basis of the first week, and follow their subsequent evolution. The occupancy probability tree [Fig. 19] shows that 26.7% of the chambers with service time efficiency less than 90% in the first week improve their service time efficiency to better than 97% in the second week and then most of them maintain this improved quality for the following weeks. Once the first week has passed, the behaviour of the chambers becomes quite stable. However, there is a small percentage of chambers which shows a definite deterioration or improvement in quality, even during the last three weeks. Also, a small percentage of the chambers shows multiple transitions across the division boundary.

Considering the general improvement trend observed at the beginning of the acceptance test, we decided to apply the cuts from the second week onwards. A chamber was selected if it exhibited a service time efficiency greater than 97% for each of the last three weeks, otherwise it was rejected. However, the transitions from the region 97%-97.5% to the region 96.5%-97% were ignored since they were considered to be due to nonpathological variations in the chamber behaviour, being within our experimental repeatability of $\pm 0.5\%$ [Fig. 20].

Table III - Distribution of chamber quality.

Chamber quality(iast three weeks)	Percentage
Always high	81.5%
(Always very high	75%)
Always low	11.4%
Single transition	
High → Low	1.4%
Low → High	4.1%
Multiple transition	1.6%

Once the service time efficiency selection had been made, the accepted chambers were examined for their average current. In Fig. 21 we show the probability density graph for their average current during the first week. Once again two different domains of chambers are observed, which begin to overlap at a current that roughly corresponds to 750 nA. We divided chambers with their average current less than 750 nA from those which showed an average current greater than 1500 nA. The chambers were then observed for the following weeks and in Fig. 22 we show the occupancy probability tree and the transitions between the two current domains. It is observed that, compared with service time efficiency, the improvement in chamber quality during the first week is even more significant as we look at their average current. In addition, a higher number of chambers shows transitions between the two current domains.

The criterion for average current selection was similar to that for service time efficiency and a chamber was accepted if it showed an average current less then 750 nA for each of the last three weeks. The transitions from the region 640nA-750nA to the region 750nA-860nA were ignored, being within our experimental repeatability of $\pm 15\%$ [Fig. 23]. The boundary of 750 nA was suggested by the shape of the current distribution. Moreover, a cut around 700-

800nA also minimizes the relative transitions across it in the last three weeks of the test. We notice that, also if the current cut to accept the chambers is set at 750 nA, 92% of them have an average current less than 300nA. We classified them as very high quality chambers.

In Table III we show the results obtained for chambers subjected to the above mentioned selection criteria.

We also observed that 25.6% of the rejections (18.5% of the total) were the chambers found unacceptable only for one of the last three weeks. A majority of these (75%) originated because of the current selection criterion and showed an improvement during the second week of the test. This means that the selection percentage would have improved only by 3.5% if the test were prolonged by one week and selection criteria applied to the last three weeks.

7. - EFFICIENCY OF SELECTION CRITERIA

In Figure 24 we show the distribution of average current, service time efficiency and standard deviation of current for the selected chambers during the last week.

The major aim of our selection criteria is to identify high quality, stable and long-life chambers. The stability of the selected chambers and their life-time can be estimated from the trend shown by current, efficiency [Table II] and rejection rate [Table IV] for each week during our acceptance test.

Table IV - Weekly rejection rate.

Week no	Rejection %age
2	15.9%
3	2.6%
4	0.4%

The percentage of rejected chambers is reduced roughly by a factor of 6 as we go from one week to the next. We can extrapolate this trend to estimate that the percentage of chambers that transit across the boundaries of our selection criteria during the following one year should be a decimal fraction. It is worthwhile mentioning here that these limits are applied for selecting high-quality chambers and the limits at which chambers cannot function as detectors are much looser, especially with regard to current. Therefore, we have to distinguish between the chambers that loose their high quality and those which fail. This makes the expected mortality rate lower than extrapolated value.

However, this prediction has to be confirmed experimentally because of the relative validity of the numerical extrapolation. In fact, a life-time evaluation performed with a large number of chambers observed for a few weeks can only provide indications of early chamber failure and it is less significant than a test performed with a comparatively small number of chambers for a long period. For this reason, we are performing a life-time test using 100 chambers, which are being observed for the last 7 months in the Astra laboratory. During this test, the chambers are maintained at 4900 volts and switched off occasionally in the case of a power failure or hardware maintainance. When switched off, they undergo a small conditioning process of 2 hours before being turned on. In Fig. 25 we show the relative distribution around the average of the weekly average current and service time efficiency. The observed widths of the distributions represent the variation of the two quantities due to environmental changes (temperature, pressure) and nonpathological intrinsic changes in the devices. During the 7 months, only two chambers have transited across the average current boundary up to 1.5 μ A,

while still maintaining the high service time efficiency. None of the chambers has shown any deterioration that makes it unacceptable for acquiring data.

Confirmation of the long life-time of our selected chambers also came from their experimental use. Roughly 1500 of them were mounted in the tracking segments where they underwent their final leakage test and their plateaux were measured [Fig. 26]. As already mentioned, roughly 2% of selected chambers did not show good plateaux and were replaced at this stage. The tracking segments were then used for different measurements, which were spread over one year. Another batch of 500 chambers was transported to Gran Sasso, installed in a mechanical structure and after the leakage and plateau measurements, was left in an uncontrolled humidity and temperature environment for more than 8 months before being put in operation again [Fig. 26].

The behaviour of both these groups of chambers agrees with a mortality rate of less than 1% per year.

8. - CONCLUSIONS

We have described the criteria applied to select high-quality limited streamer chambers for the large volume detector being installed in the Gran Sasso Laboratory.

Table V shows the rejection rate averaged over all the quality control procedures for the first 2900 chambers. The percentages show small differences compared with those reported in the previous tables, due to the fact that the acceptance tests were operated using slightly different criteria in the early phase of the process.

Table V- Overall rejection percentages

Chamber failure	Rejection percentage
Conditioning	4.4%
Long term acceptance test.	19.8%
Leakage control	0.2%
Unacceptable plateau.	1.5%
Total	25.9%
	=====

Experimental results from the life-time test and from practical use of the selected chambers show that the mortality rate of these chambers is less than 1% per year. This value fits to the requirements of the LVD experiment.

ACKNOWLEDGEMENTS

We are grateful to B. Alpat and C. Artemi for participating in the early stage of the Astra tests. We are also thankful to M. Basile for useful suggestions.

REFERENCES

1. C. Bari et al., *Nucl. Instr. and Meth.* **A264**(1988)5.
2. E. Bellotti, *Nucl. Instr. and Meth.* **A264** (1988).
3. G. Charpak et al., *IEEE Trans. Nucl. Sci.* **NS-25** (1978)122.
4. J. Fisher. et. al., *Nucl. Instr. and Meth.* **151** (1978)451.
5. E. Iarocci, *Nucl. Instr. and Meth.* **217** (1983)30.
6. Wit Busza, *Nucl. Instr. and Meth.* **A265**(1988)210.
7. G. Battistoni et al., *Nucl. Instr. and Meth.* **202** (1982) 459.
8. G. Battistoni et al., *Nucl. Instr. and Meth.* **164** (1979) 57.
9. M. Caria et. al., *Nucl. Instr. and Meth.* **A260**(1987)368.
10. R. de Sangro et. al., SLD WIC NOTE -110.
11. F. Fabbri et al., CERN-EP/87-134 (1987).
12. R. Birsa et al., CERN-EP/90-93 (1990).
13. B. Alpat, Dipartimento di Fisica and Sezione INFN di Perugia (Doctoral Thesis 1989).
14. M. Anelli et al., *Nucl. Instr. and Meth.* **A289**(1990)294.
15. Opal experiment (internal note).
16. G. Bari et al., Frascati Report LNF-91/004(P) (1991).
17. F.L. Fabbri et al., LVD 033 (MEM).

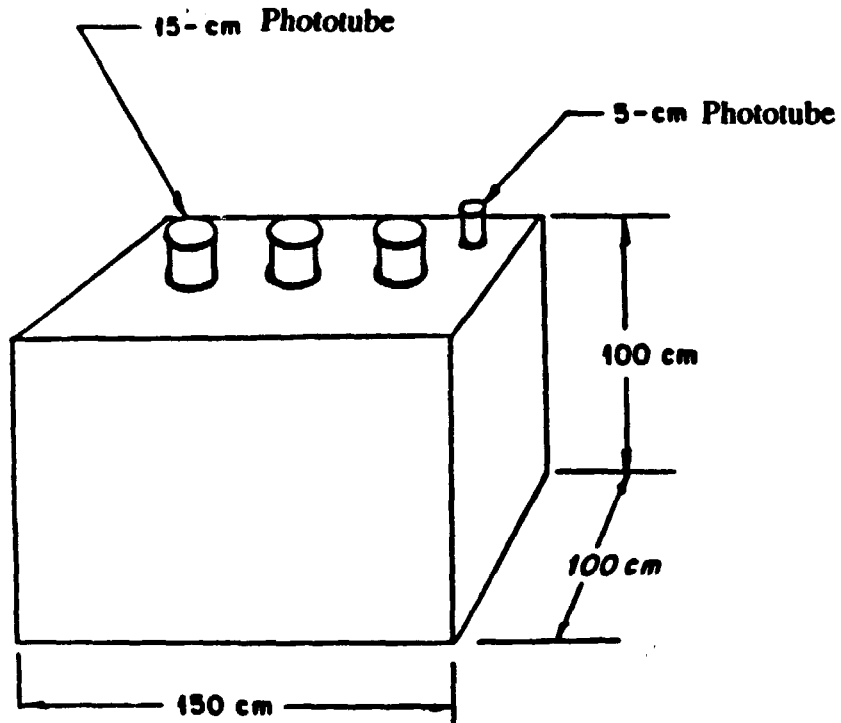

FIG. 1 - LVD scintillator counter. The detector uses 1520 counters filled with liquid scintillator.

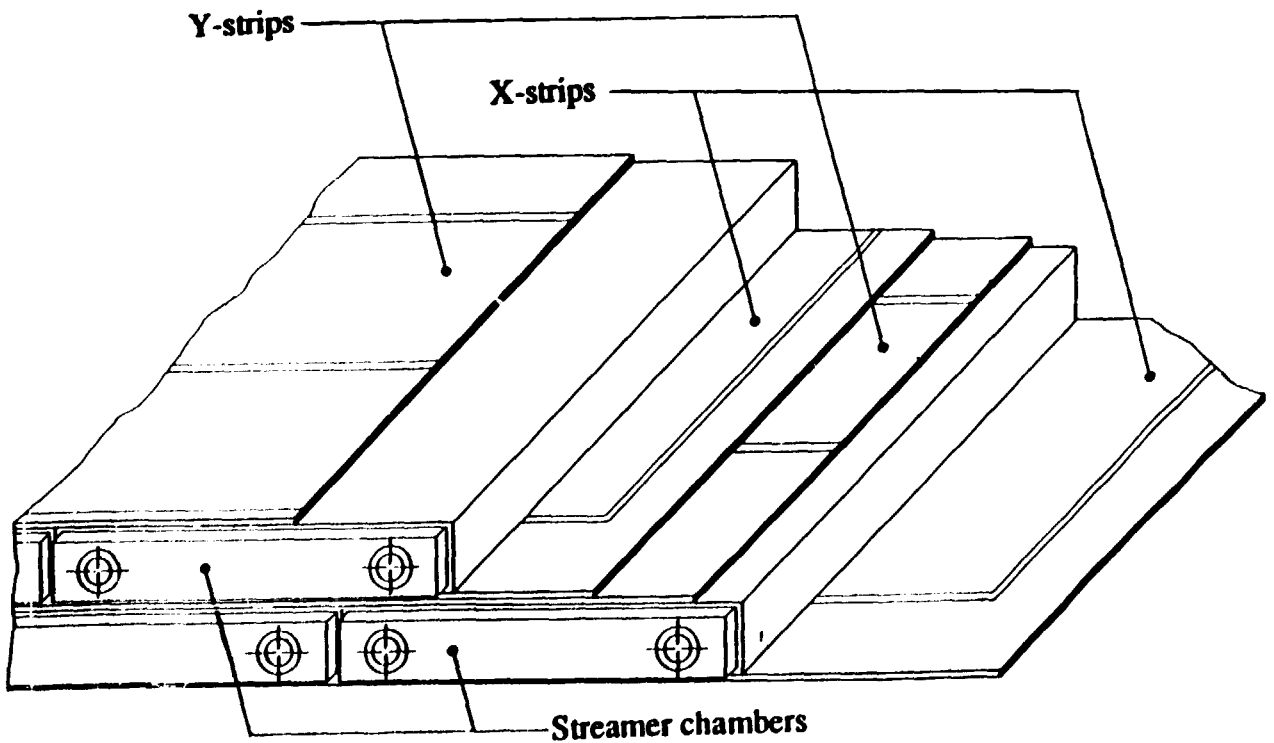

FIG. 2 - Streamer chambers and strip layout in LVD tracking segments.

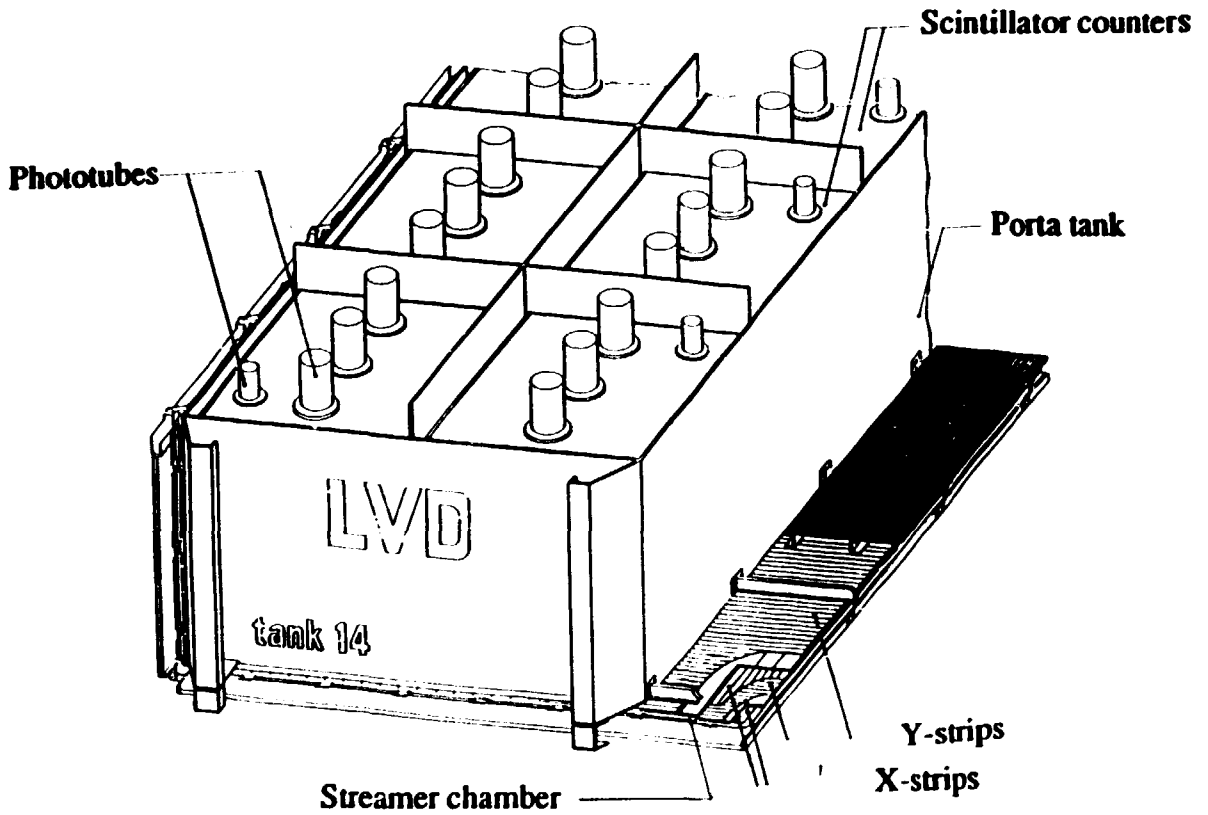

FIG. 3 - One module with a porta tank containing tracking segment.

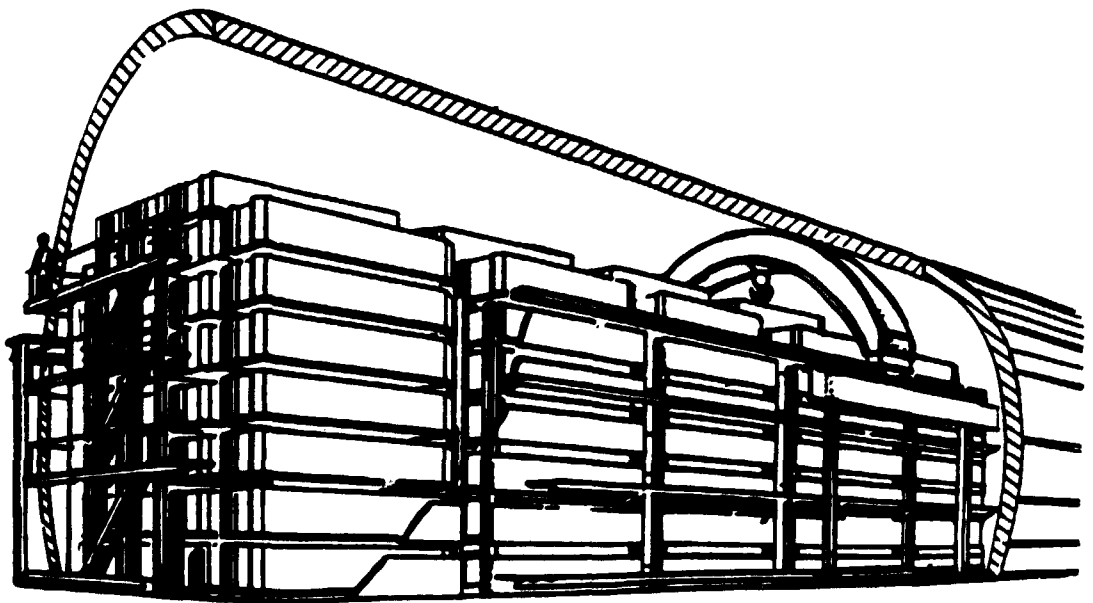

FIG. 4 - A general overview of the LVD apparatus.

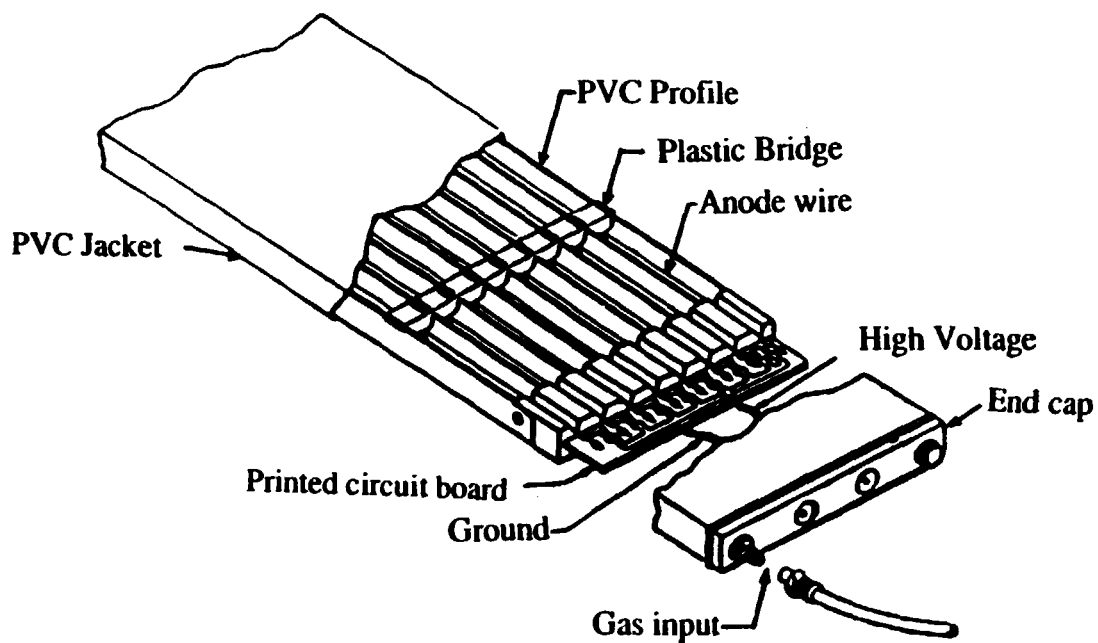

FIG. 5 - LVD streamer chamber.

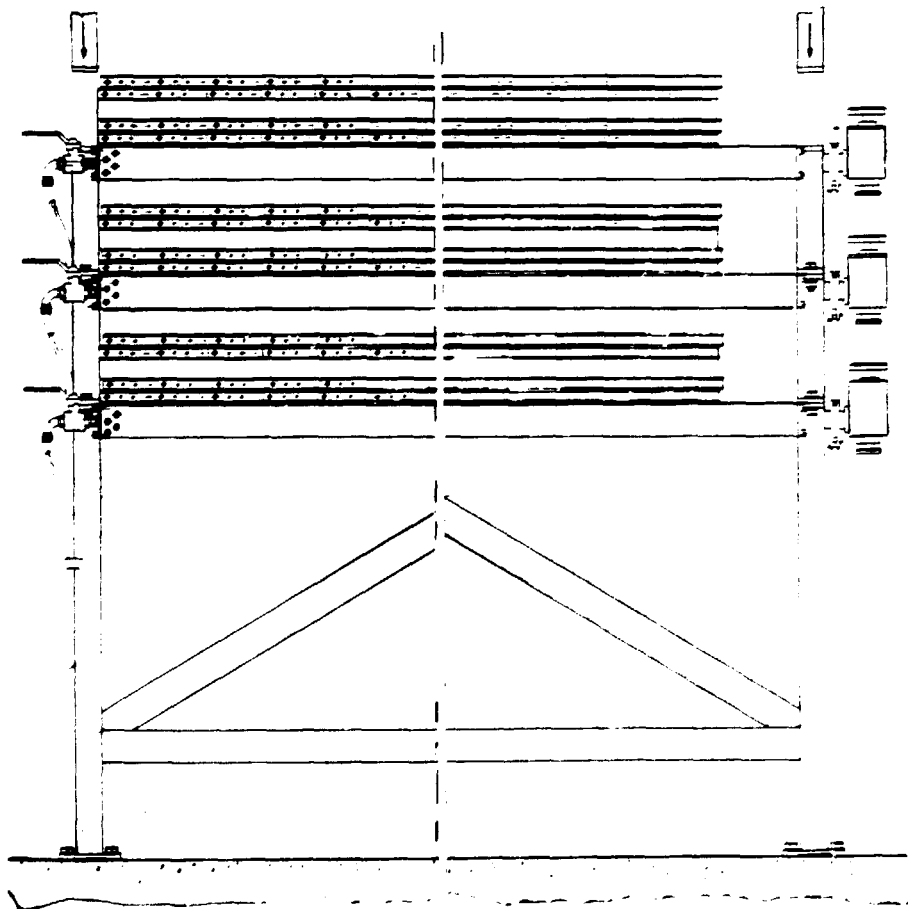

FIG. 6 - Front view of Astra steel structure to house streamer chambers during the test.

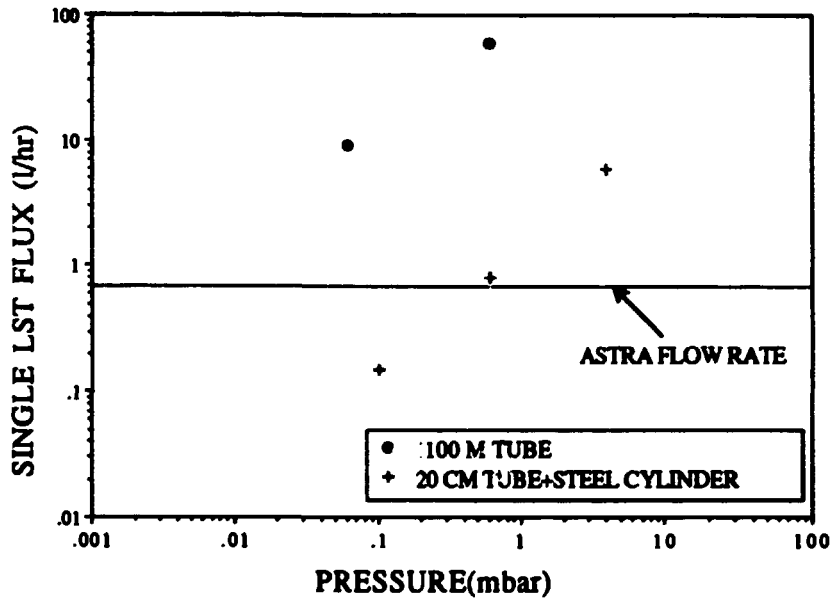

FIG. 7 - Effect of a cylindrical steel impedance. The drop of pressure across impedance is plotted against flux through it.

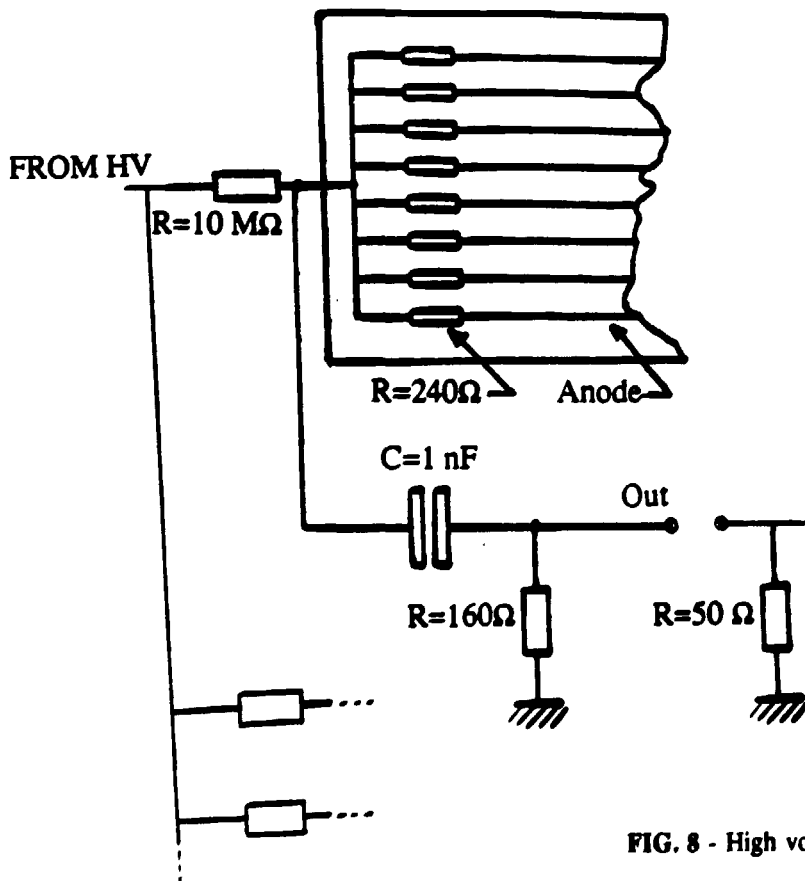

FIG. 8 - High voltage distribution circuit.

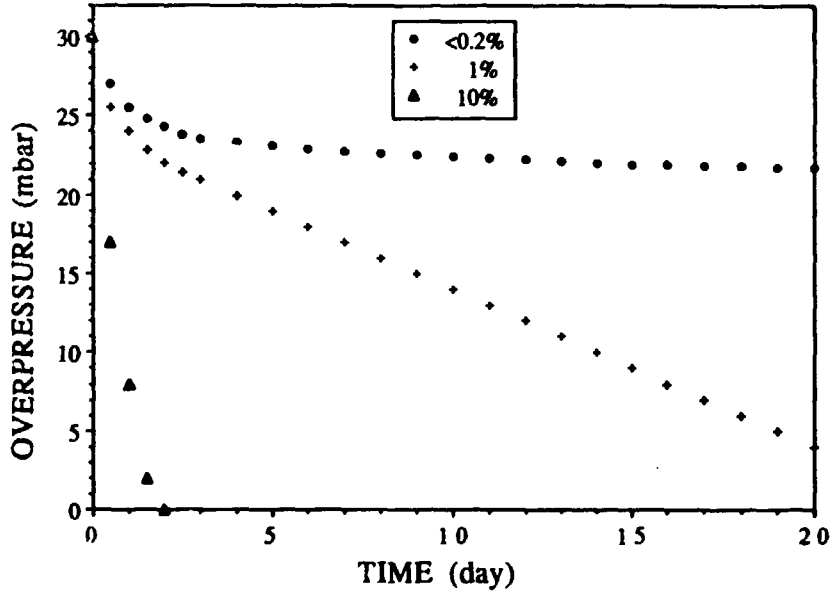

FIG. 9 - Pressure drop inside the closed chambers having leakage rate of $<0.2\%$, 1% and 10% by volume per day respectively.

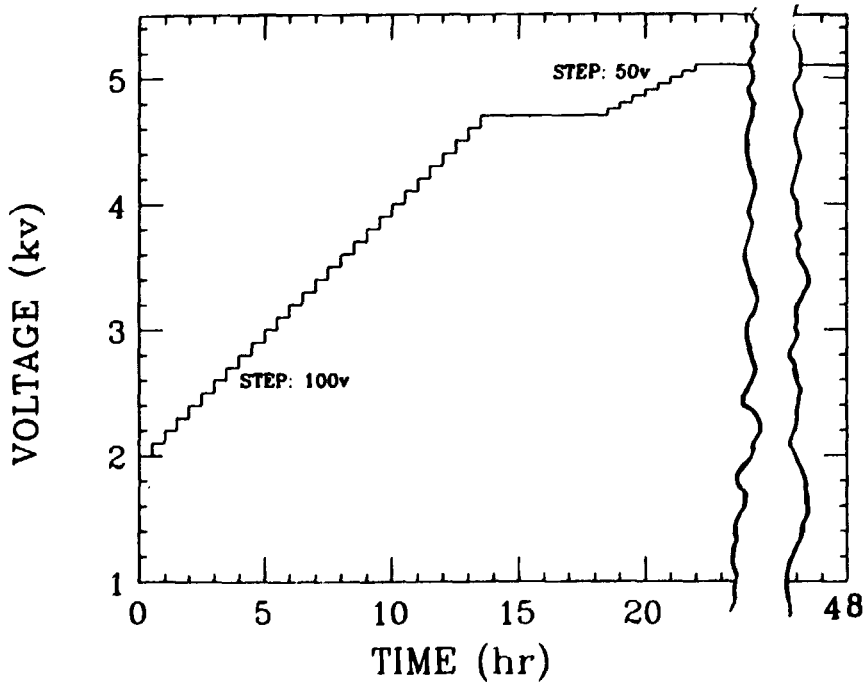

FIG. 10 - High voltage sequence of conditioning.

CHANNEL A SUBJECT 17/11/89 15:12:50
 FILE: ASTRA

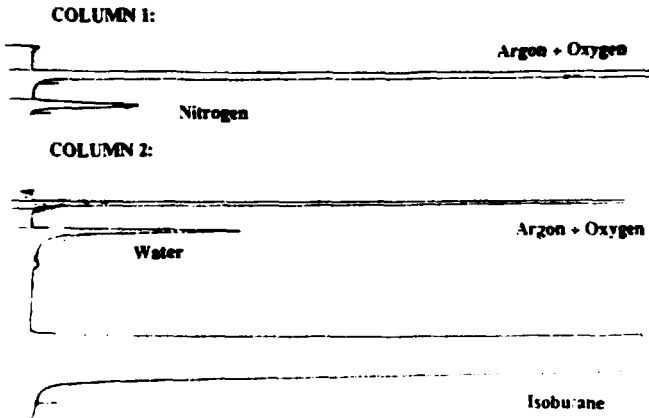

FIG. 11 - A typical gas chromatogram obtained during acceptance tests.

MIXTURE COMPONENTS	PERCENTAGE
ISOBUTANE	69.27
ARGON	30.02
NITROGEN	0.31
WATER	0.40

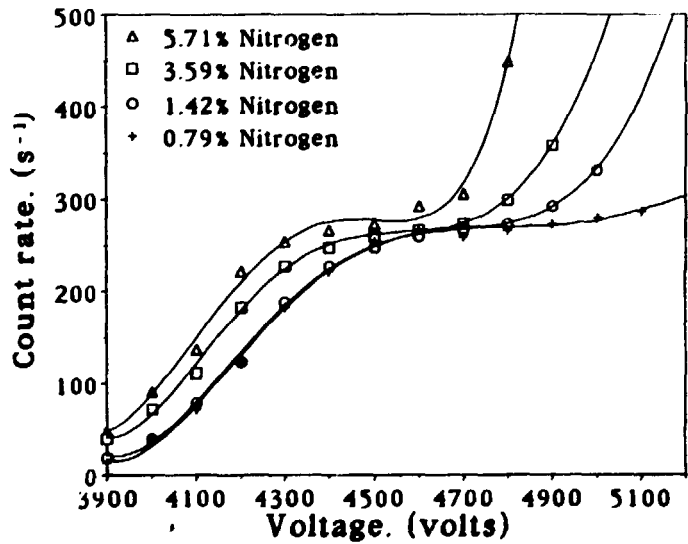

FIG. 12 - Variation in singles rate plateau as top of a new isobutane cylinder having impurities is being consumed.

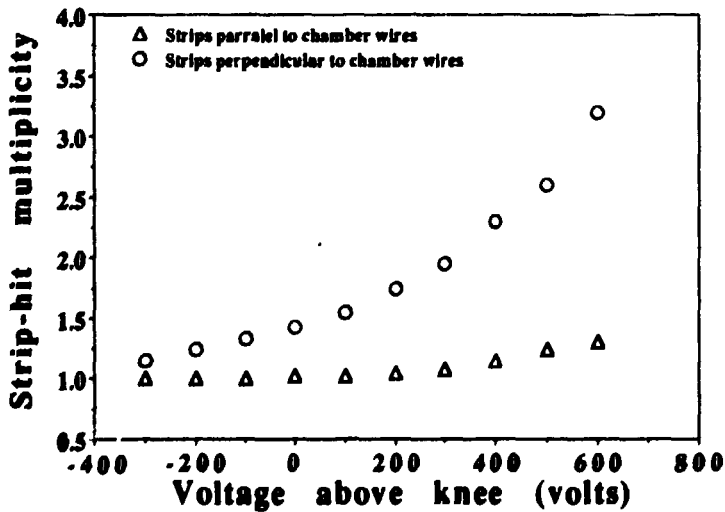

FIG. 13 - Multiplicity of pulses induced on the strips parallel and perpendicular to anode wire, against chamber voltage.

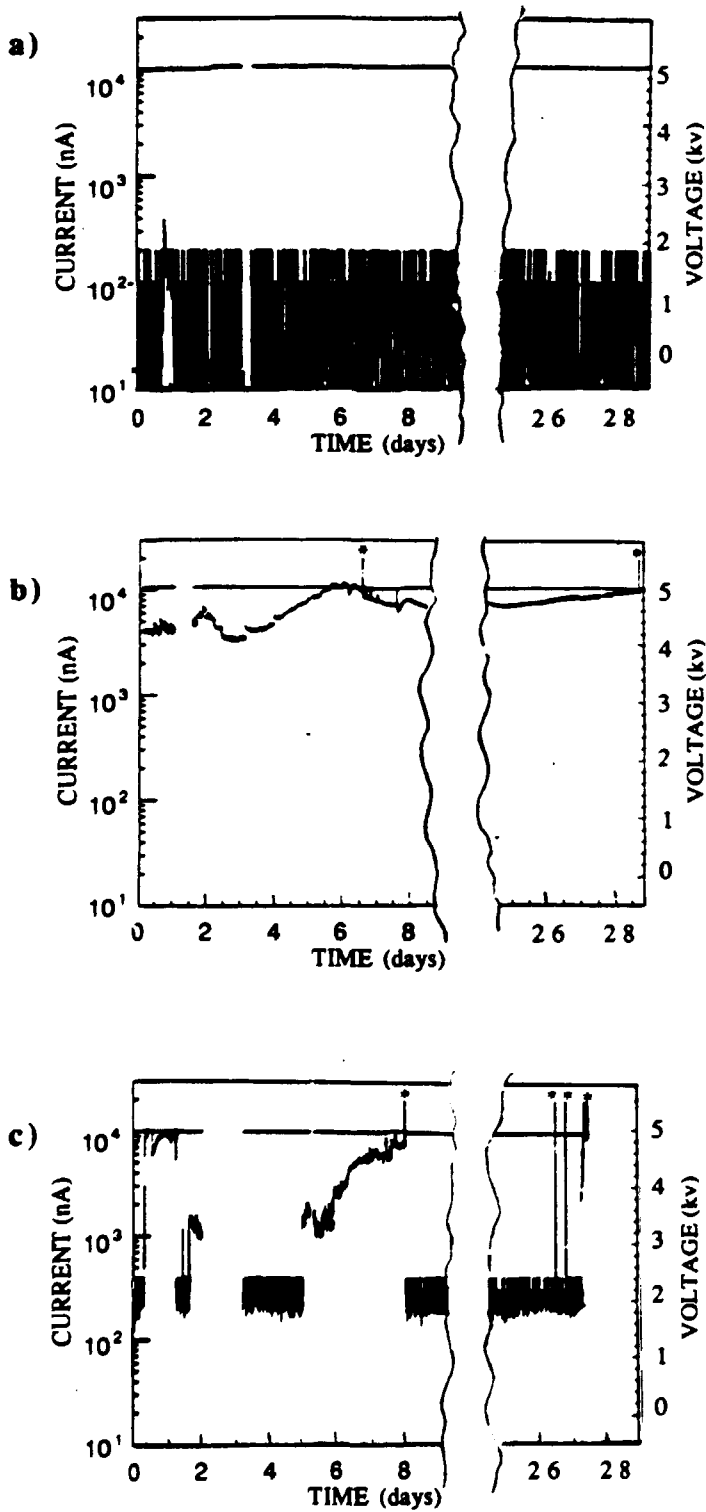

FIG. 14 - History graphs for some typical chambers. The lower end of each vertical line shows average current during 12 minutes, the upper end shows maximum current and asterisk, the overcurrent state. Voltage is shown by a horizontal line above the current lines. The discontinuity in the graph c) corresponds to a pause in the test for hardware maintenance etc.

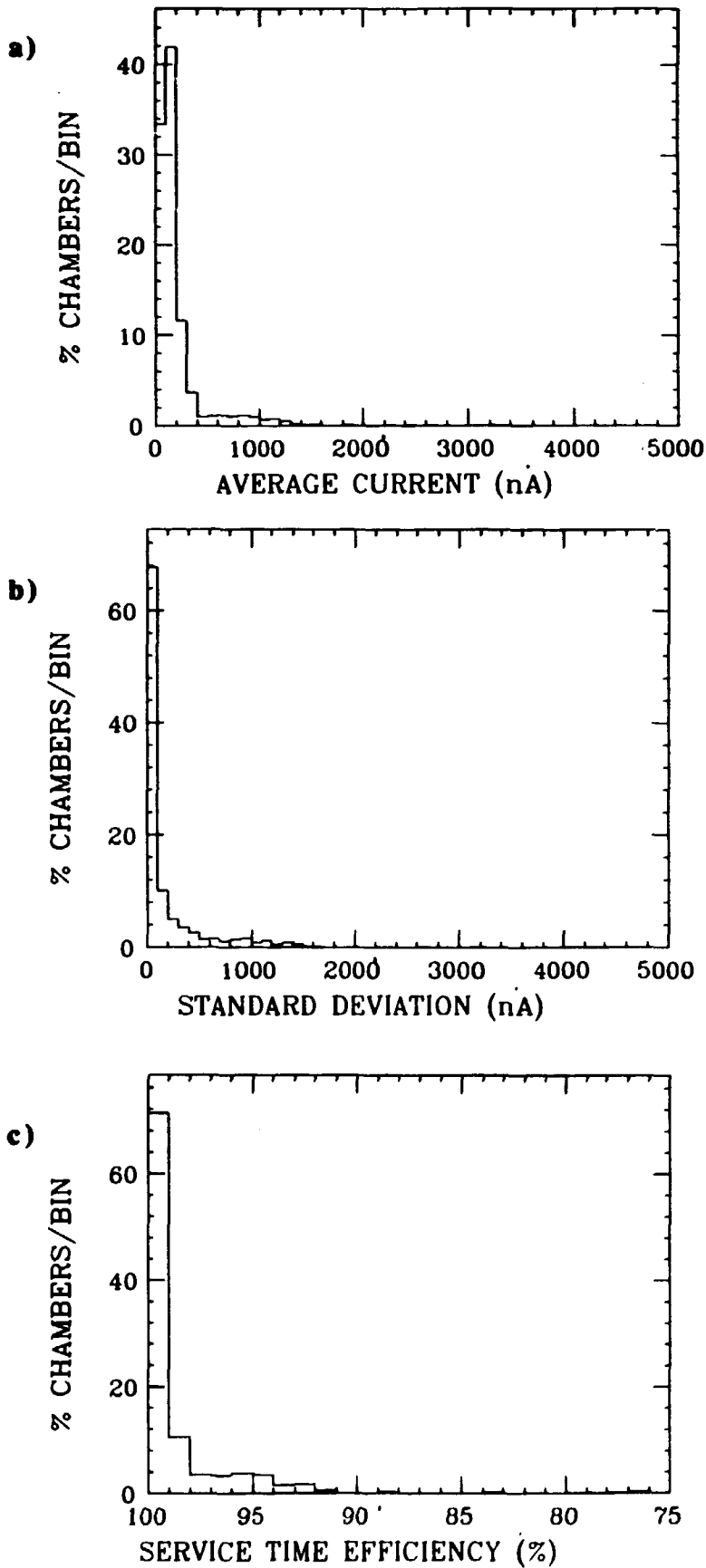

FIG. 15 - Some typical distributions based on the first week of observations: (a)average current, (b)standard deviation of current, (c)service time efficiency.

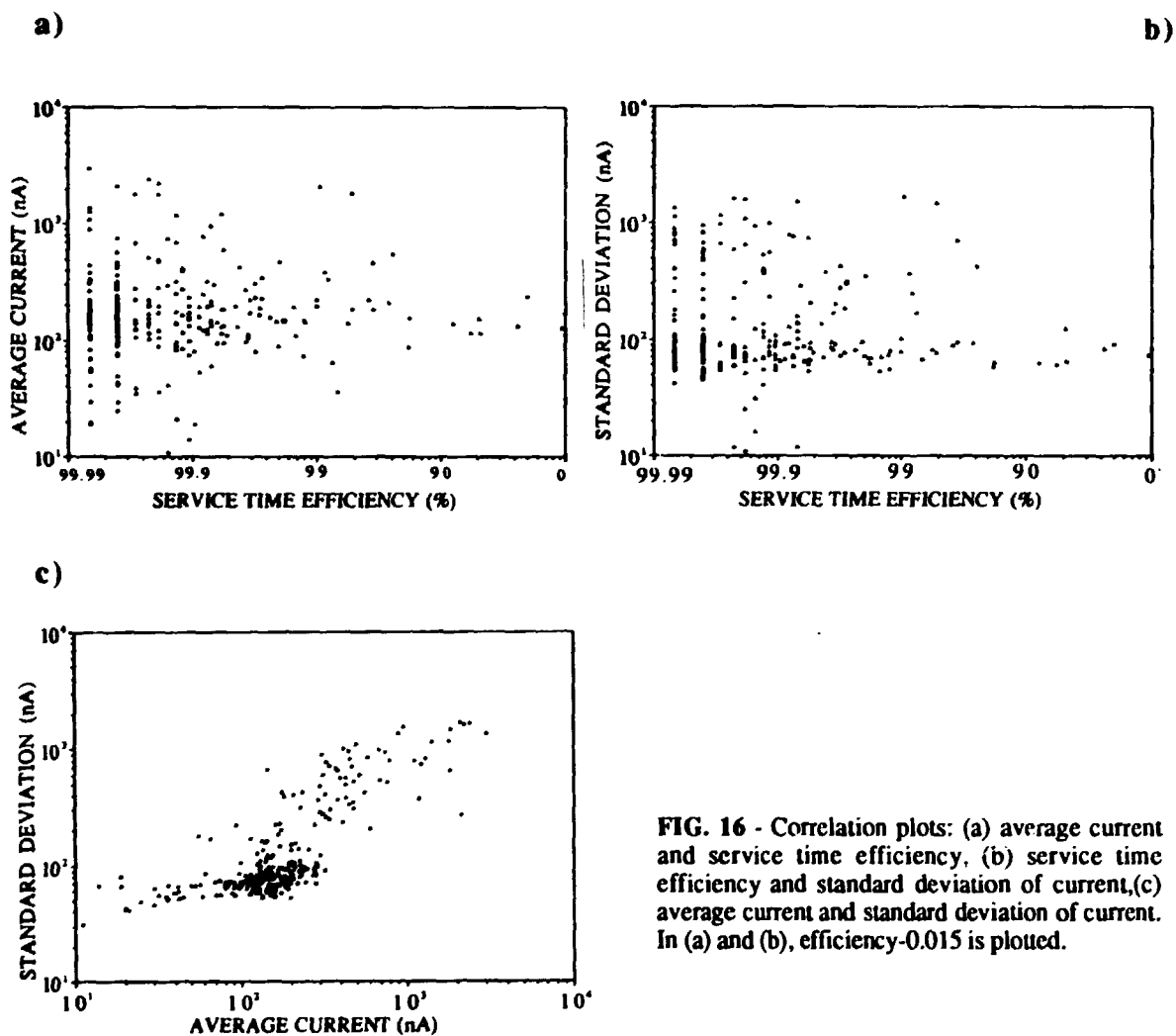

FIG. 16 - Correlation plots: (a) average current and service time efficiency, (b) service time efficiency and standard deviation of current, (c) average current and standard deviation of current. In (a) and (b), efficiency-0.015 is plotted.

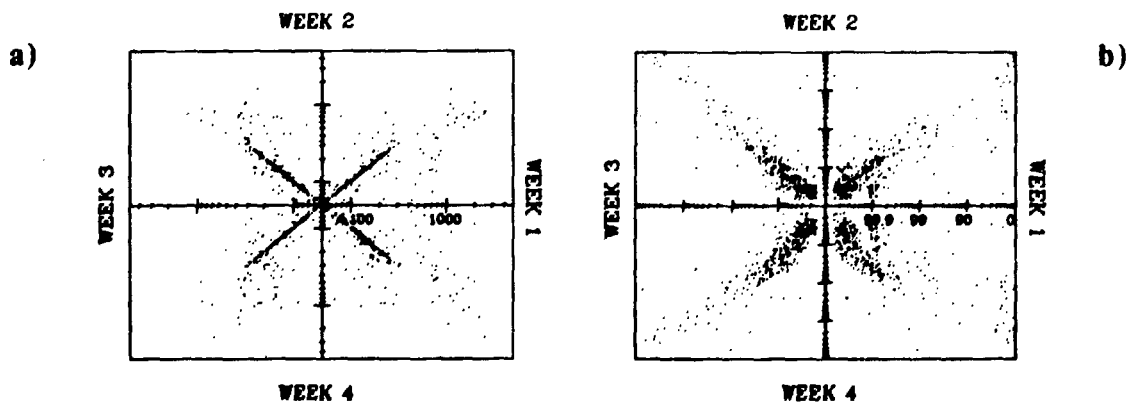

FIG. 17 - Evolution trend in (a) average current, (b) service time efficiency. Each quadrant compares respective quantity for the given two weeks where each chamber is shown by a dot. Quantities are expressed in nA and % respectively. In (b), efficiency-0.015 is plotted.

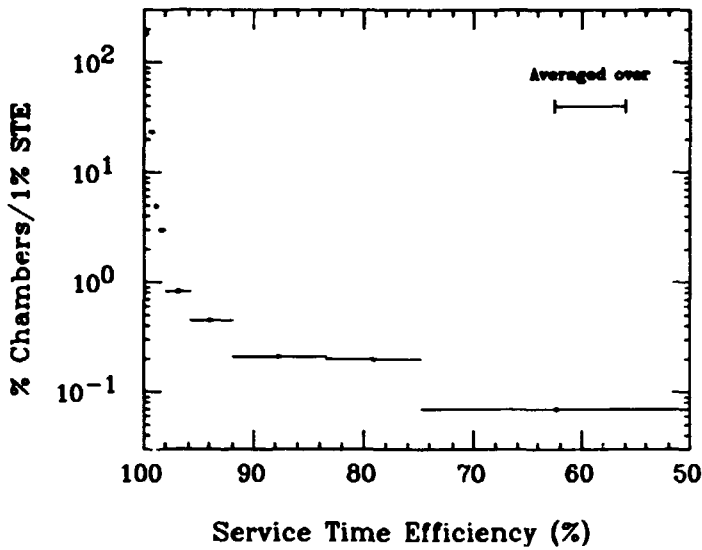

FIG. 18 - Probability density graph for service time efficiency during the first week of observations.

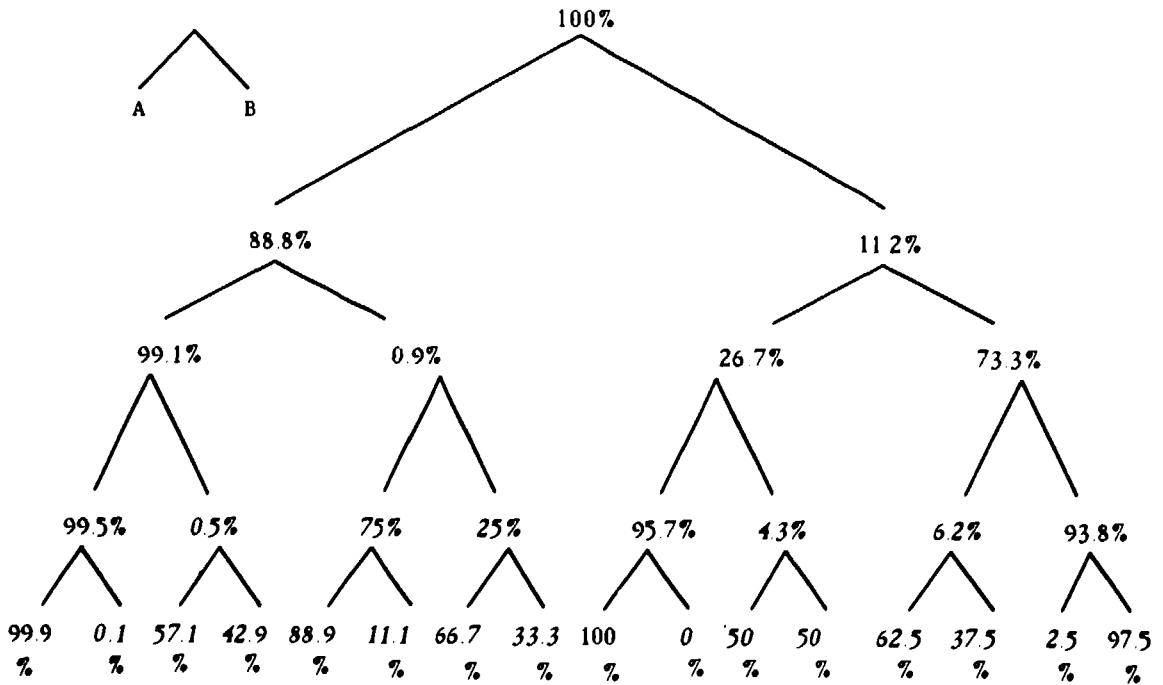

FIG. 19 - Occupancy probability tree for service time efficiency. On the basis of first week's service time efficiency the chambers are divided into class A (efficiency > 97%) and class B (efficiency < 90%). In the following weeks, a chamber transits from B to A if it reaches an efficiency greater than 97% and from A to B if its efficiency becomes less than 97%. However the chambers within 97 to 97+0.5% interval remain in class A until their efficiency becomes less than 97-0.5%. The numbers written in italics have a statistical error of > 30%.

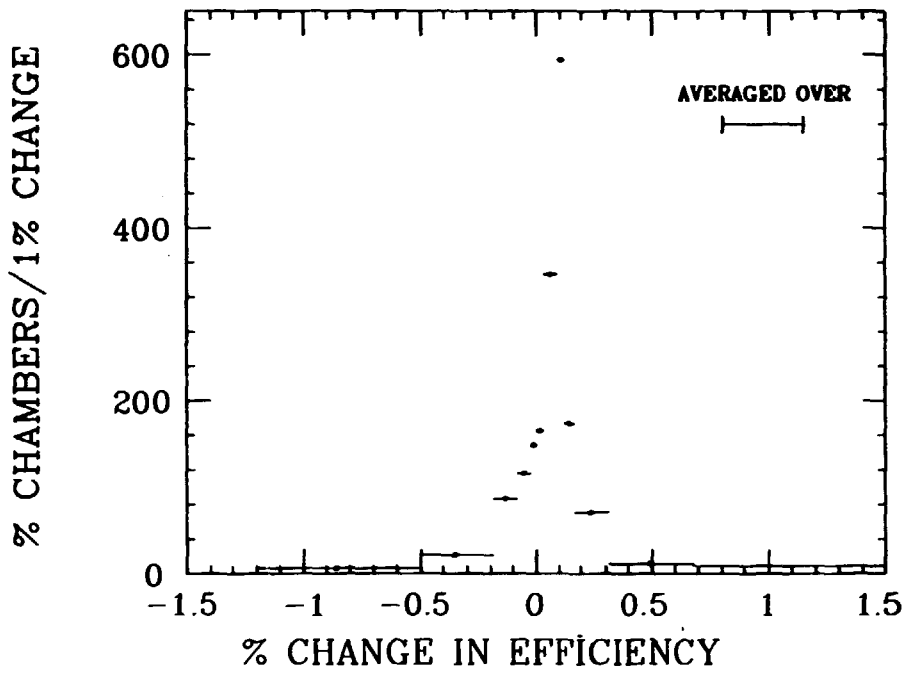

FIG. 20 - Distribution of percentage change in the service time efficiency as we go from second week to the third.

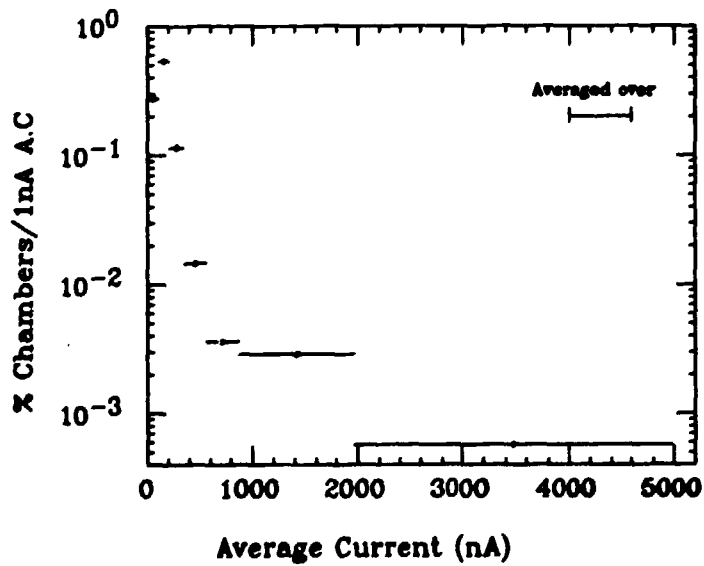

FIG. 21 - Probability density graph for average current.

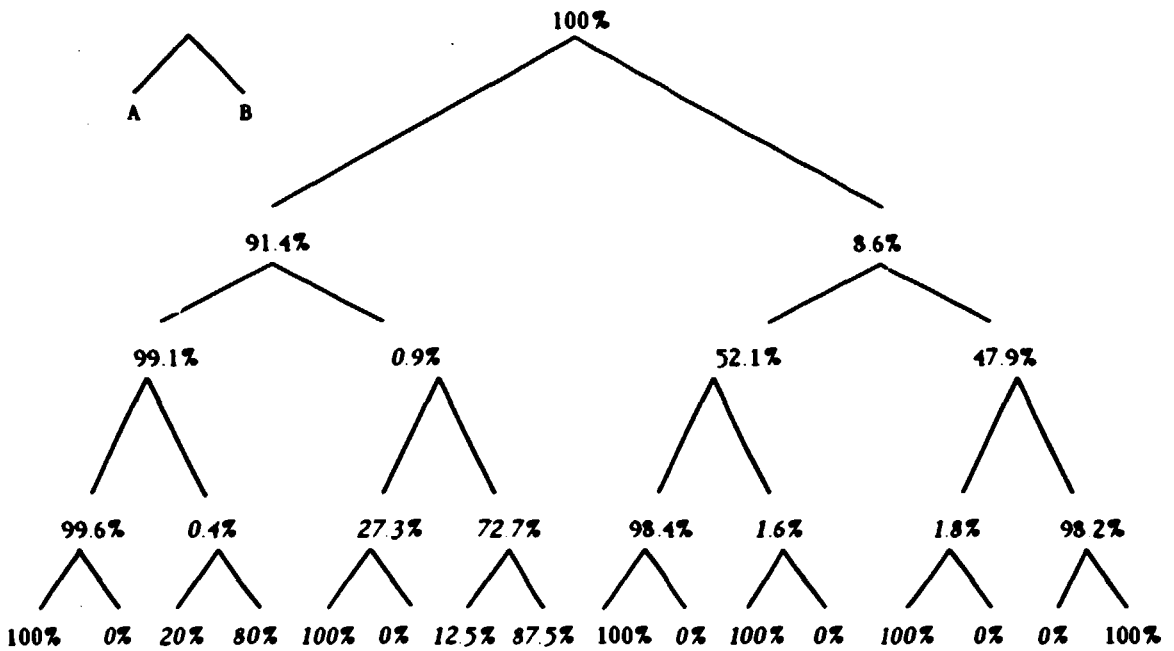

FIG. 22 - Occupancy probability tree for average current. The first week's divisions are <750nA (for A) and >1500nA (for B). In the following weeks, transition from B to A is recognized if a chamber reaches a current <750nA and from A to B if its current becomes >750nA. Chambers within interval 750 to 750-15% remain in A until their current becomes >750+15%.

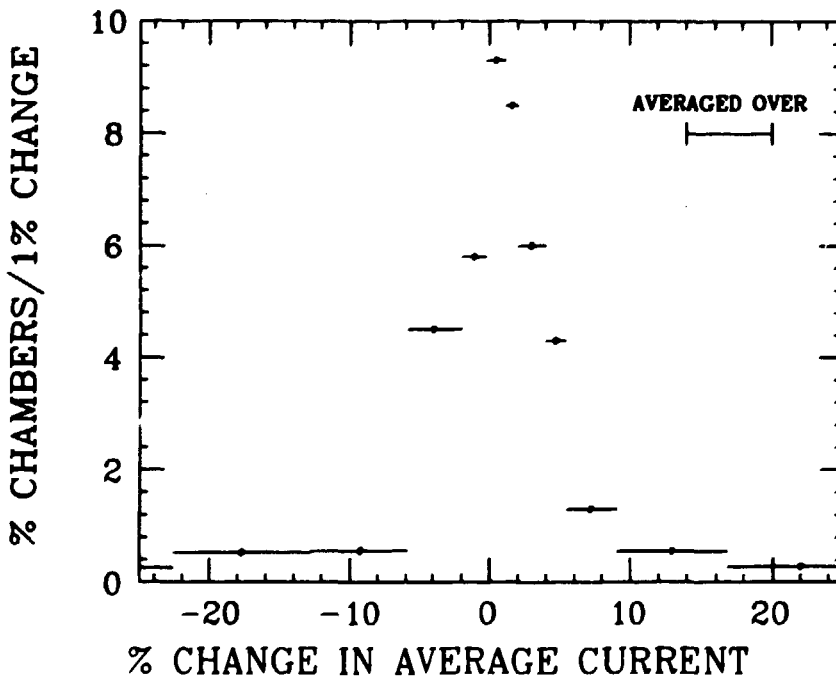

FIG. 23 - Distribution of percentage change in the average current as we go from second week to the third.

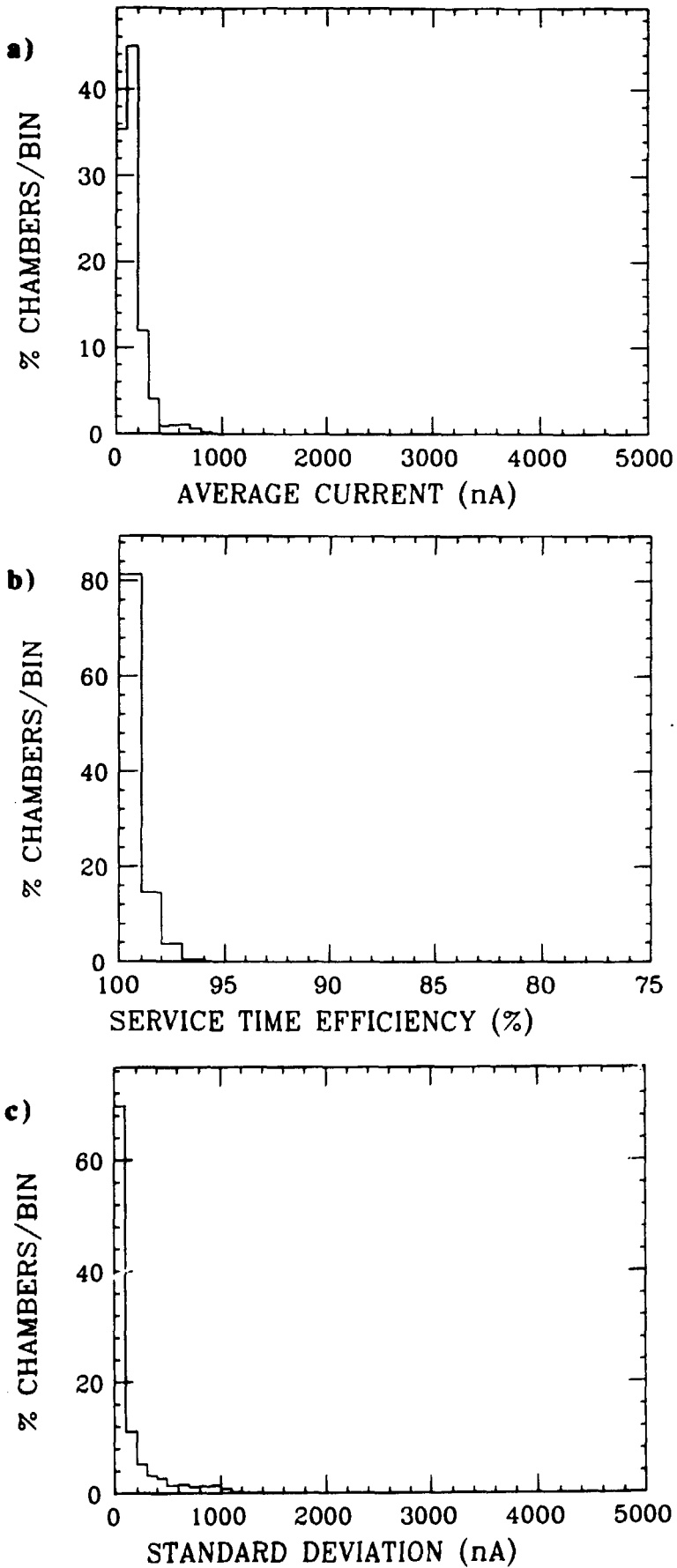

FIG. 24 - Distribution of average current, service time efficiency and standard deviation for the selected chambers.

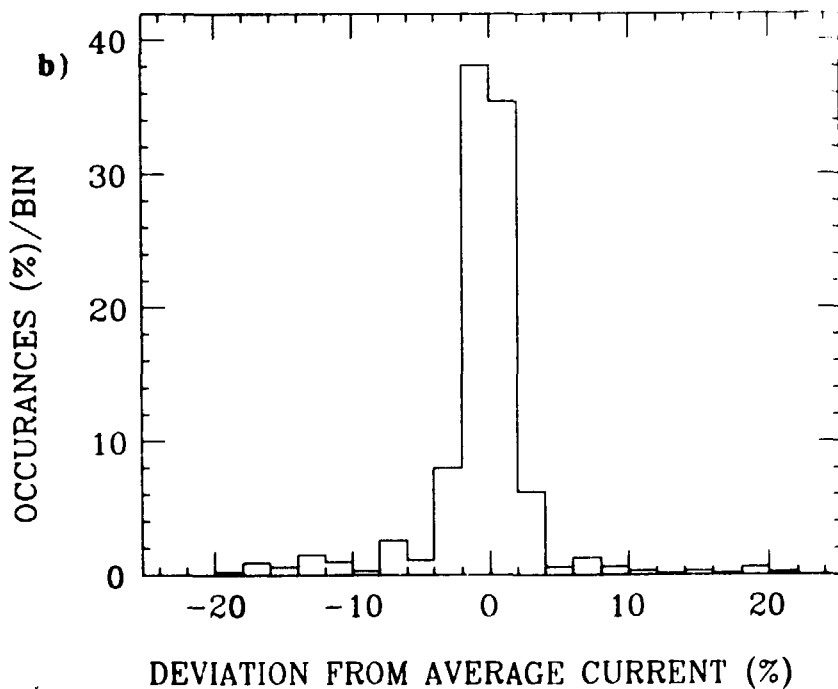
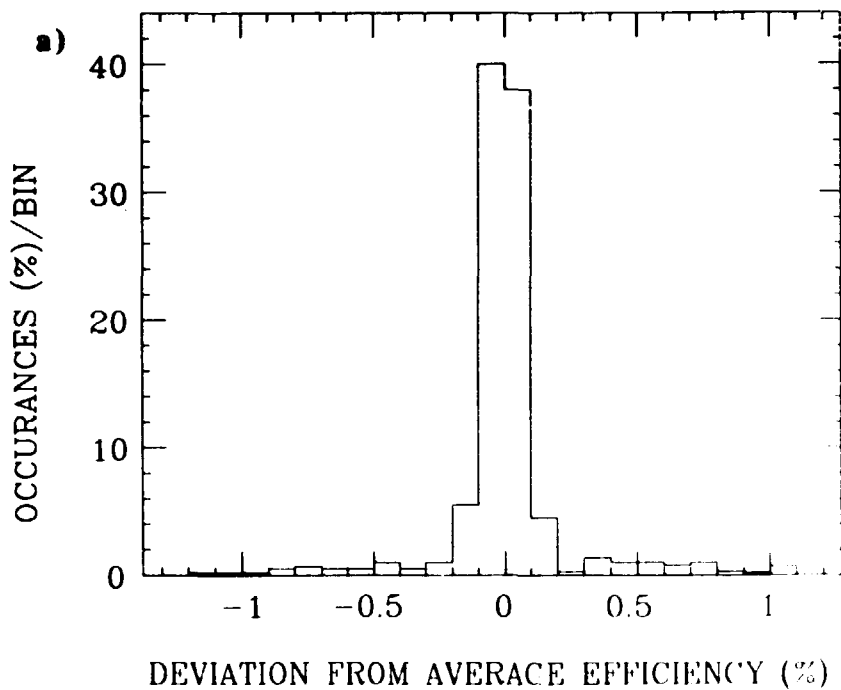

FIG. 25 - Percentage variation probability histograms for 7 month test: (a) service time efficiency and (b) average current.

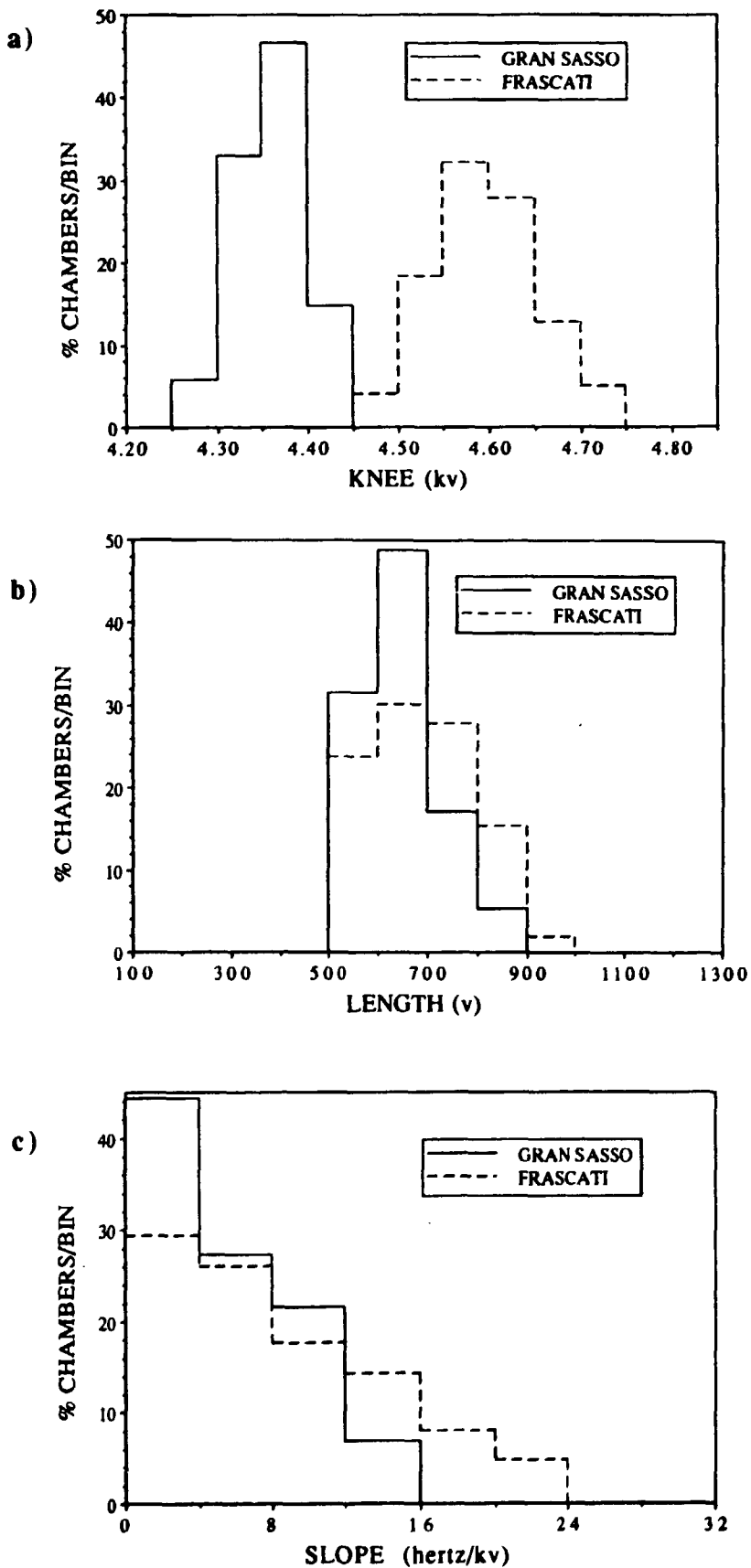

FIG. 26 - Distribution of knee, length and slope of the plateaux acquired in Gran Sasso and Frascati. A shift of knee towards lower voltage is observed at Gran Sasso due to lower atmospheric pressure.