

---

# Fan-Out Module

for

# TANSY-KM5

by

Ryszard Rydz,

Lennart Norberg, Lasse Urholm

and Gudmar Grosshög

CTH-RF-83

July 1991

---

**Fan-Out Module**

for

**TANSY-KM5**

by

**Ryszard Rydz,  
Lennart Norberg, Lasse Urholm  
and Gudmar Grosshög**

**Department of Reactor Physics  
Chalmers University of Technology  
ISSN 0281-2775**

**CTH-RF-83**

**Fan-Out Module  
for  
TANSY-KM5**

by  
**Ryszard Rydz, Lennart Norberg, Lasse Urholm  
and Gudmar Grosshög**



**Department of Reactor Physics  
Chalmers University of Technology**

CTH-RF-83 91-07-01.

# Contents

## List of Figures

Fig.1. The Fan-Out Module	2
Fig.2. FAN-OUT Front Panel	3
Fig.3. Block Diagram	4
Fig.4. Circuit Diagram for Board TANSY2	5
Fig.5. Circuit Diagram for Board TANSY3	6
Fig.6. Component Layout for Board TANSY2	7
Fig.7. Component Layout for Board TANSY3	8
Fig.8. Board TANSY2 Layer 1	9
Fig.9. Board TANSY2 Layer 2	10
Fig.10. Board TANSY3 Layer 1	11
Fig.11. Board TANSY3 Layer 2	12

## List of Tables

Table 1. Component List for Board TANSY2	13
Table 2. Component List for Board TANSY3	16

## The Fan-Out Module

The FAN-Out Module is a driver module for three Time-to-Digital units and one multiscaler unit. The 16 input signals come from the Ortec CO 1600 coincidence unit. The module is partly shown in figure 1. Most of the module is hidden behind the flat cables connected to the module.

Referring to figure 3, "Block Diagram", page 4, the ECL signals are picked up by a differential line receiver and distributed directly to three ECL output drivers and one ECL-to-TTL converter. The TTL signals are down-counted in a 12 bit counter. Four outputs are used giving a count down factor of 256, 32, 4 or 1. A data selector controlled by a hexadecimal rotary switch selects one group of the down-counted signals. These are presented to the scaler output connector by an ECL output driver.

The connectors for the flat cables contain 34 pins. 32 of these are used for the 16 ECL lines. Signal earth is connected to the remaining two lines.

The electronic components are mounted on two boards named Tansy2 and Tansy3. The first of these contains the count-down logic and the second contains the input and the output drivers. The detailed drawings of the boards are presented in figure 4, "Circuit Diagram for Board TANSY2", page 5, and figure 5, "Circuit Diagram for Board TANSY3", page 6.

The placing of the components is shown in figure 6, "Component Layout for Board TANSY2", page 7, and figure 7, "Component Layout for Board TANSY3", page 8. The circuit layers on the boards are shown in four figures, figure 8, "Board TANSY2 Layer 1", page 9, to figure 11, "Board TANSY3 Layer 2", page 12. Finally, a component list is given in table 1, "Component List for Board TANSY2", page 13 and table 2, "Component List for Board TANSY3", page 16

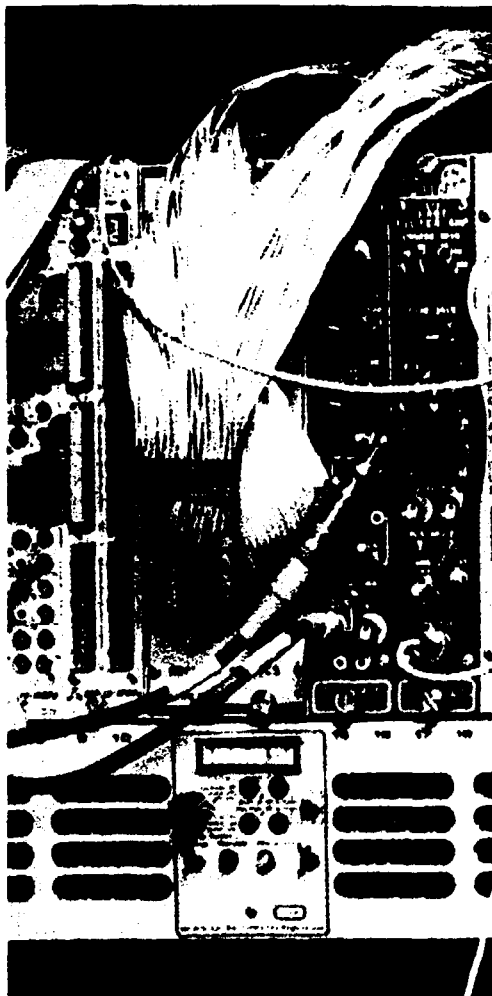

Fig.1. The Fan-Out Module

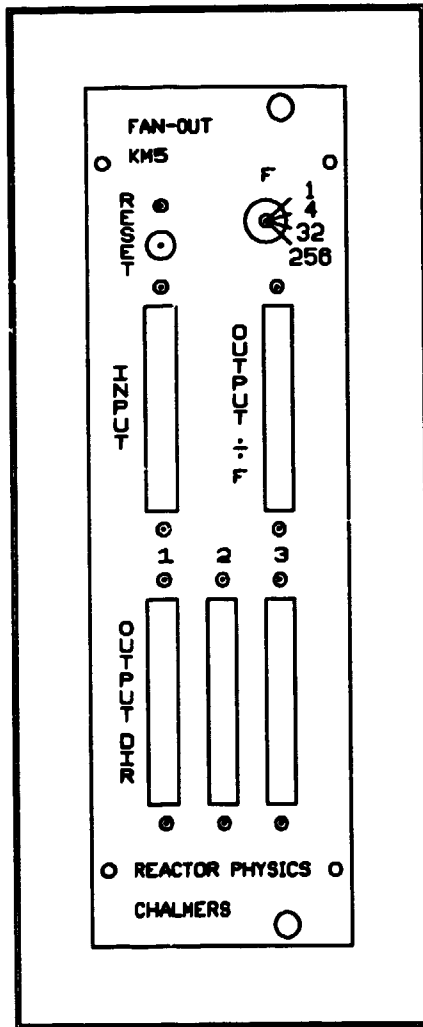

Fig.2. FAN-OUT Front Panel

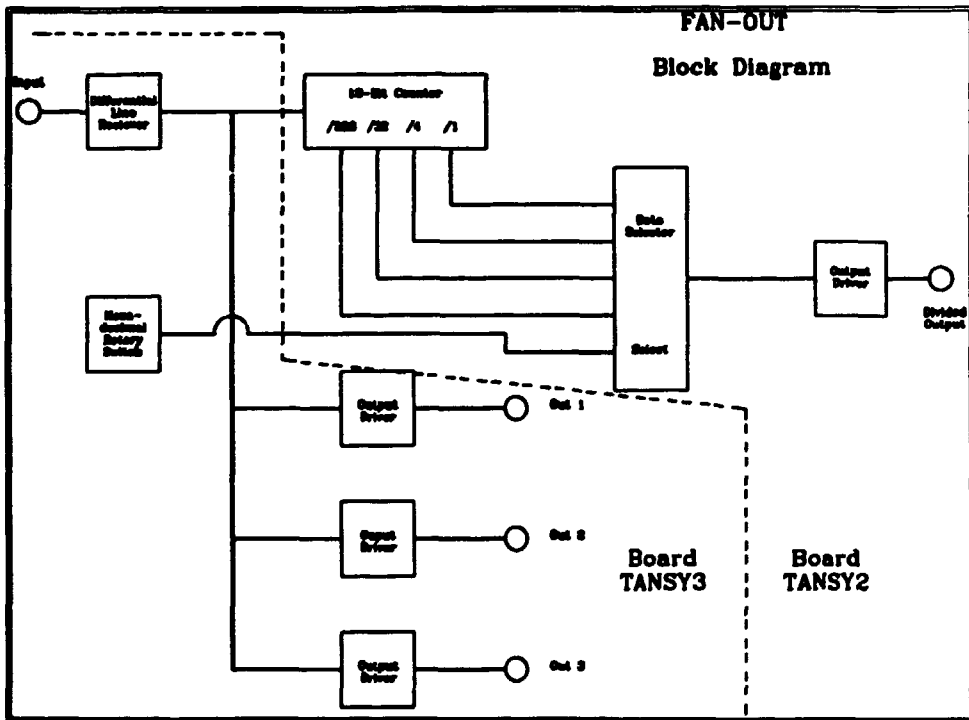

Fig.3. Block Diagram

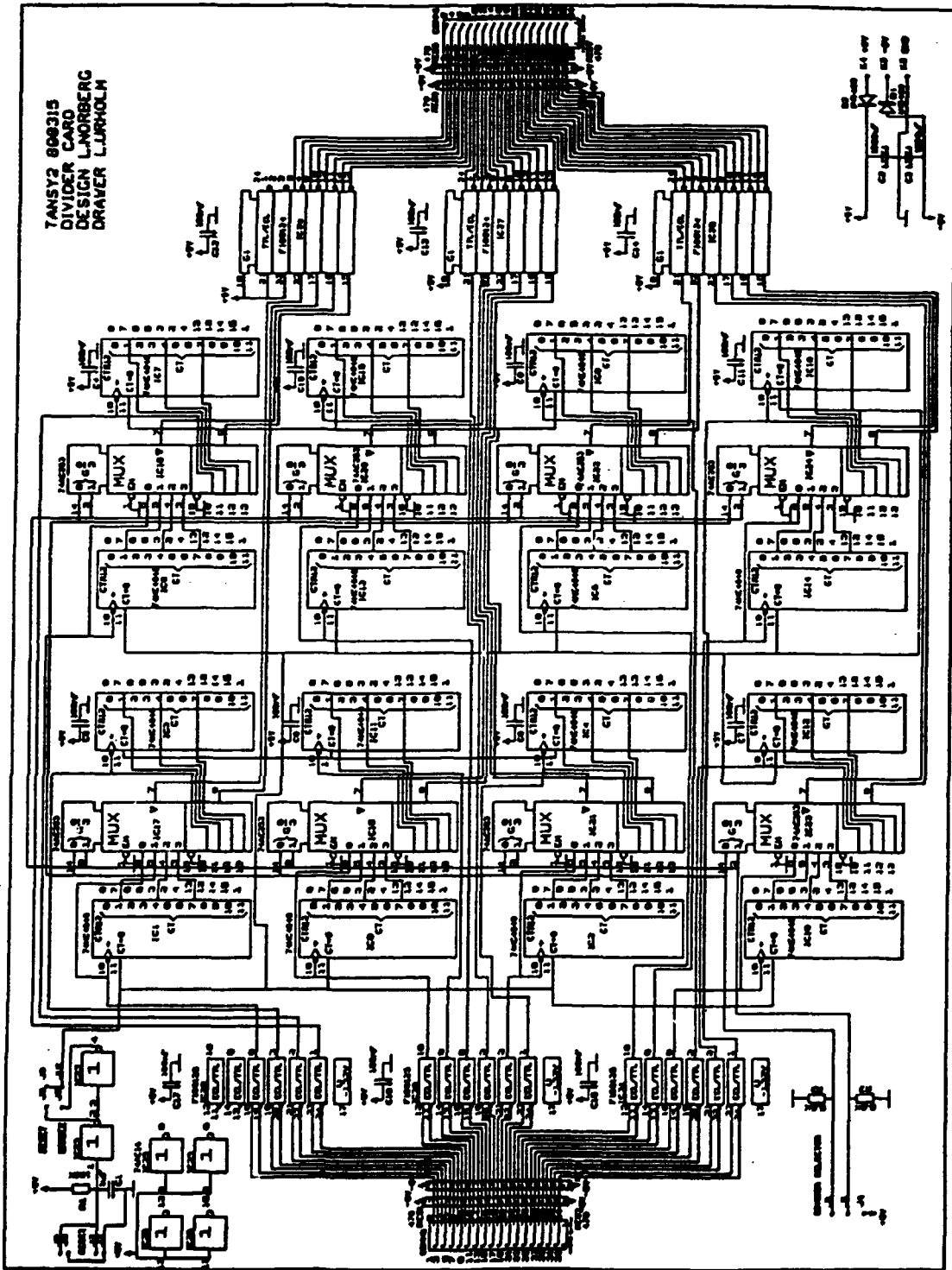

Fig.4. Circuit Diagram for Board TANSY2



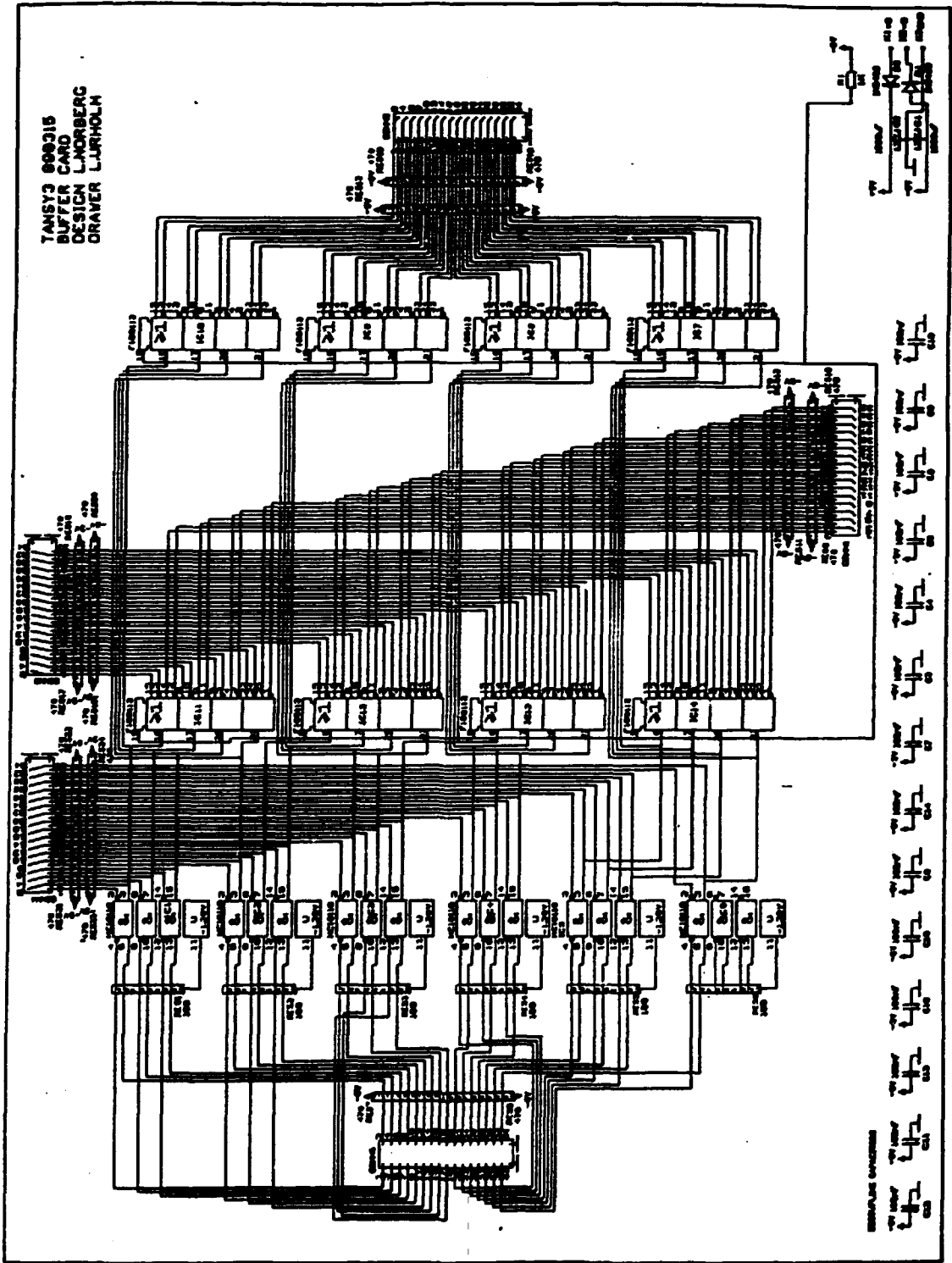

Fig.5. Circuit Diagram for Board TANSY3

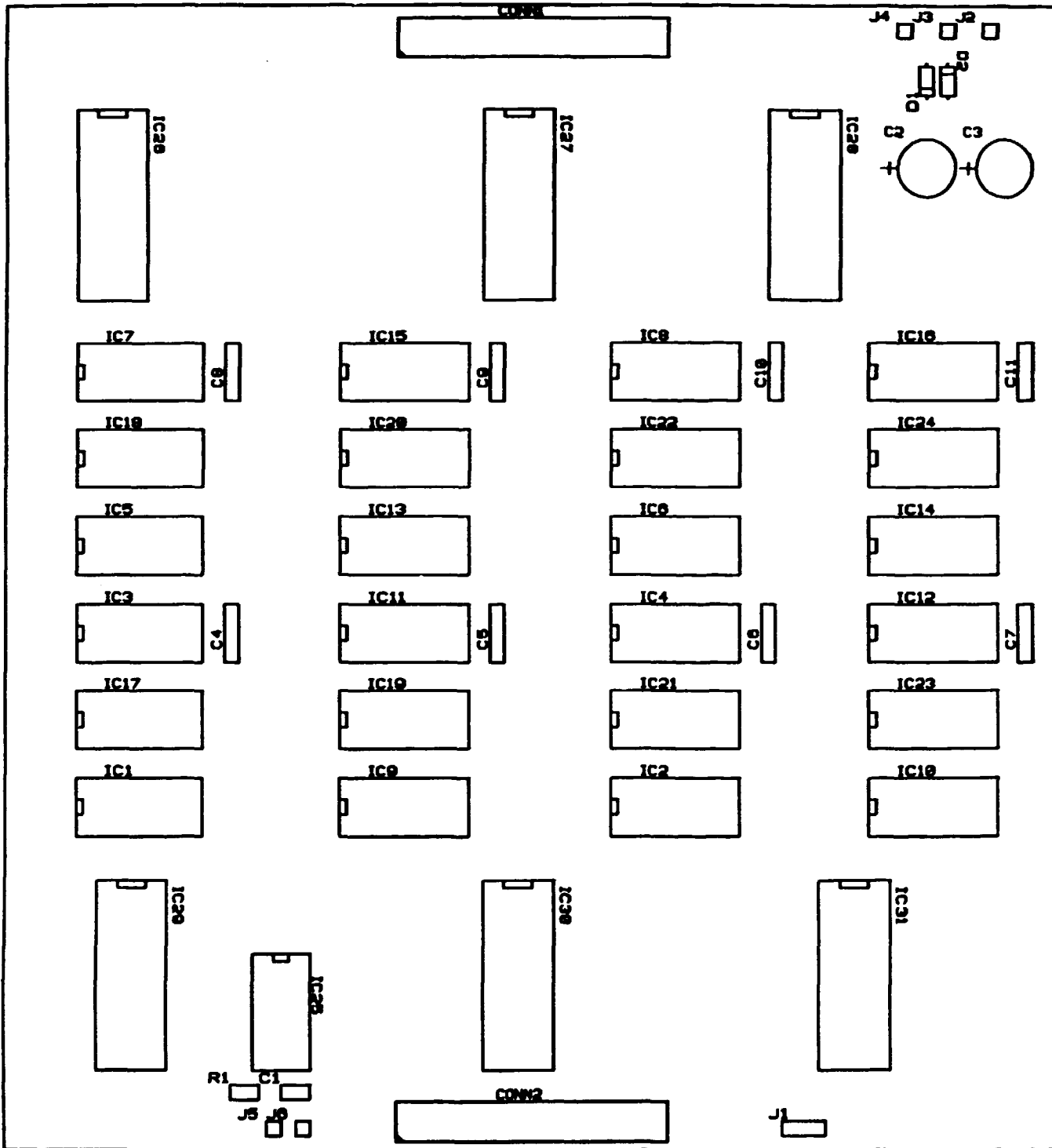

Fig.6. Component Layout for Board TANSY2

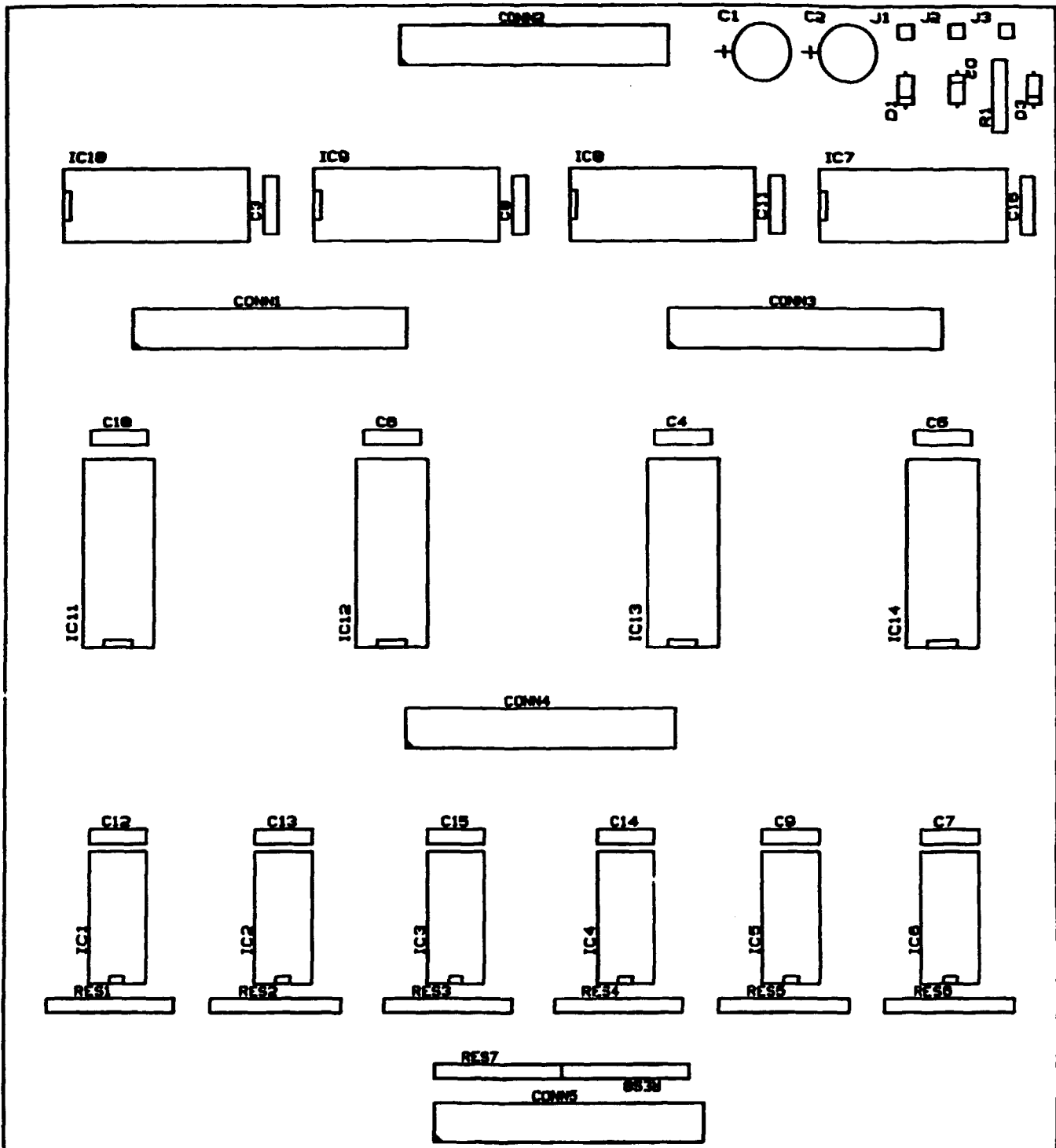

Fig.7. Component Layout for Board TANSY3

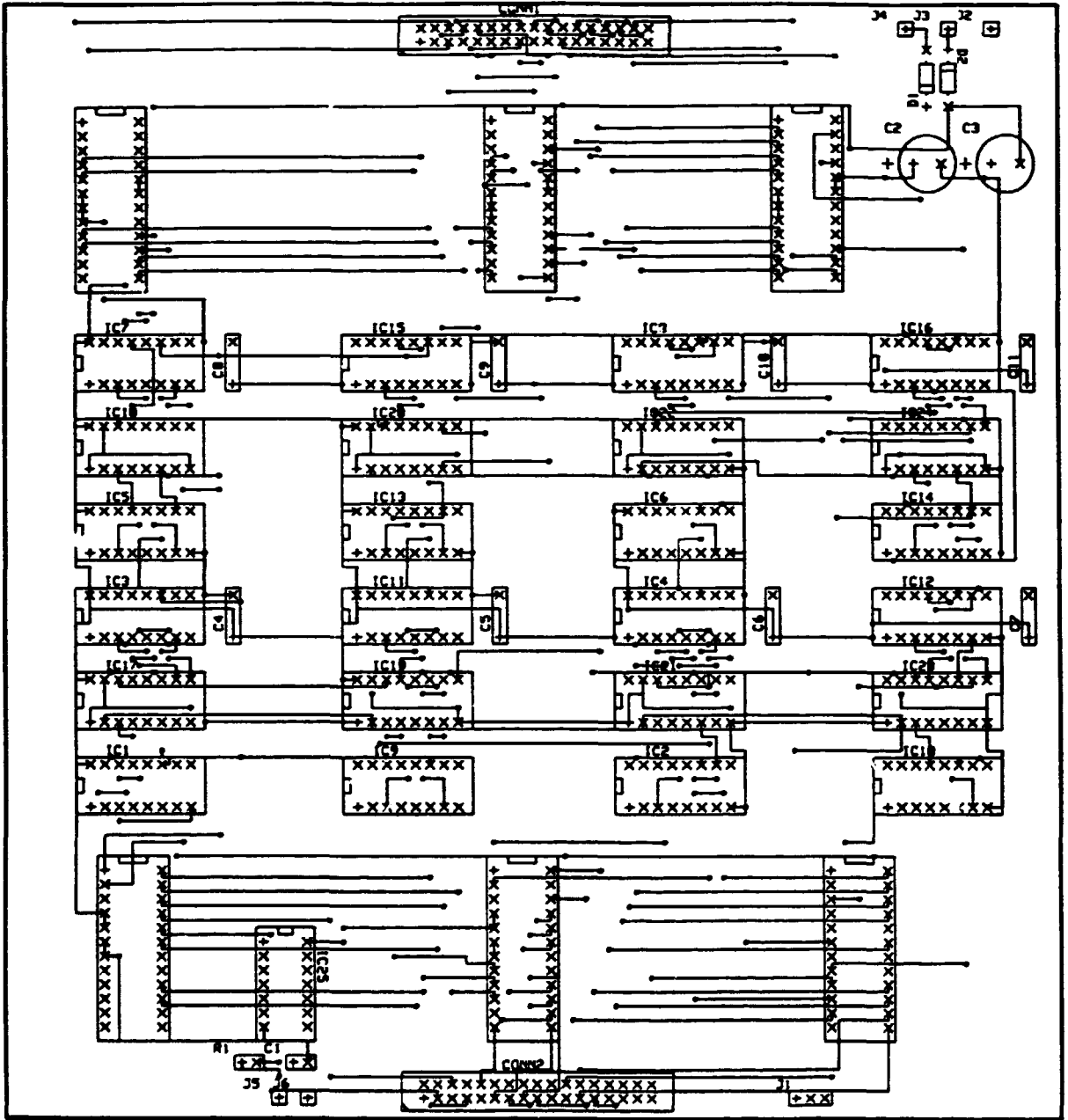

Fig.8. Board TANSY2 Layer 1

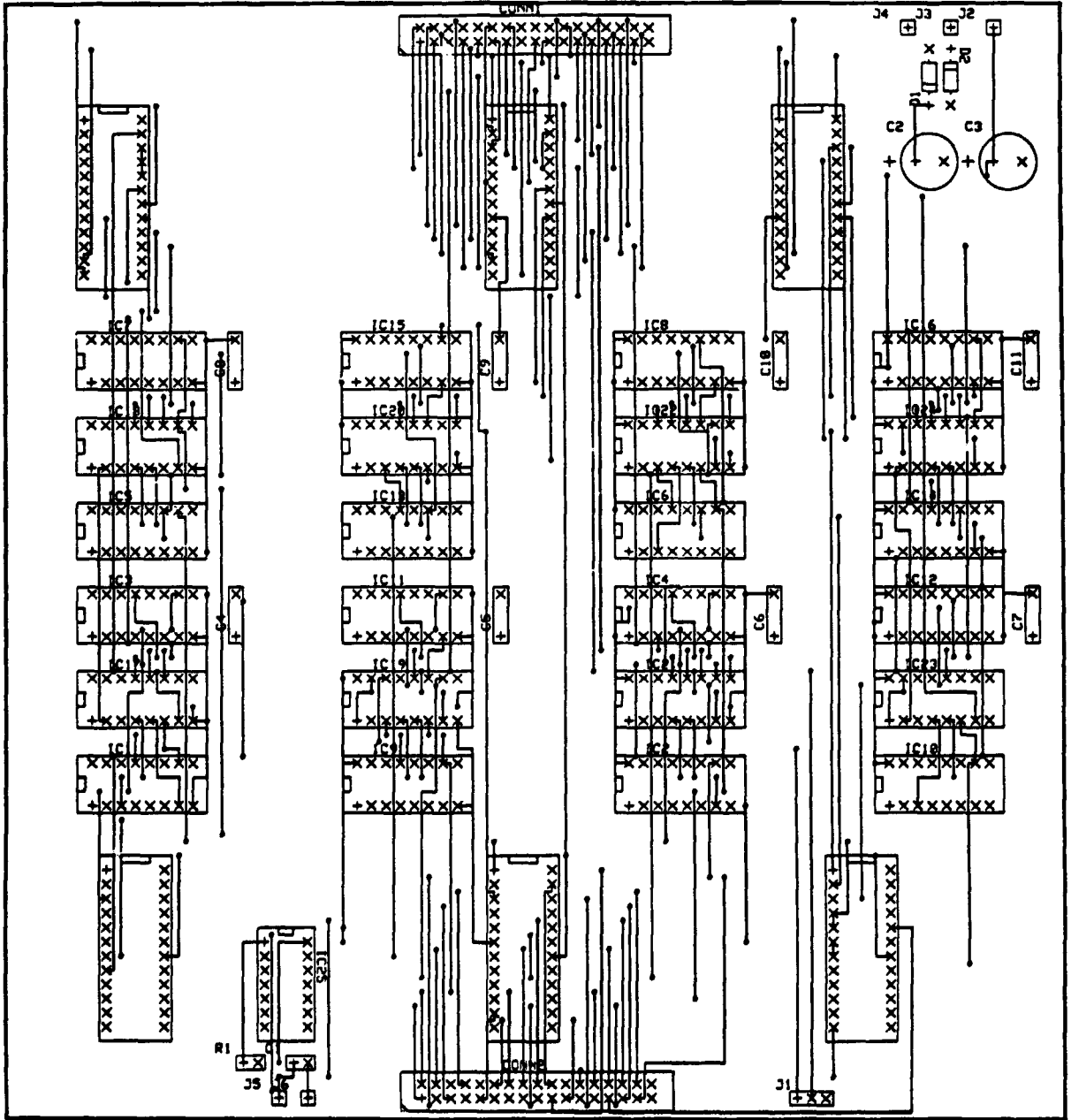

Fig.9. Board TANSY2 Layer 2

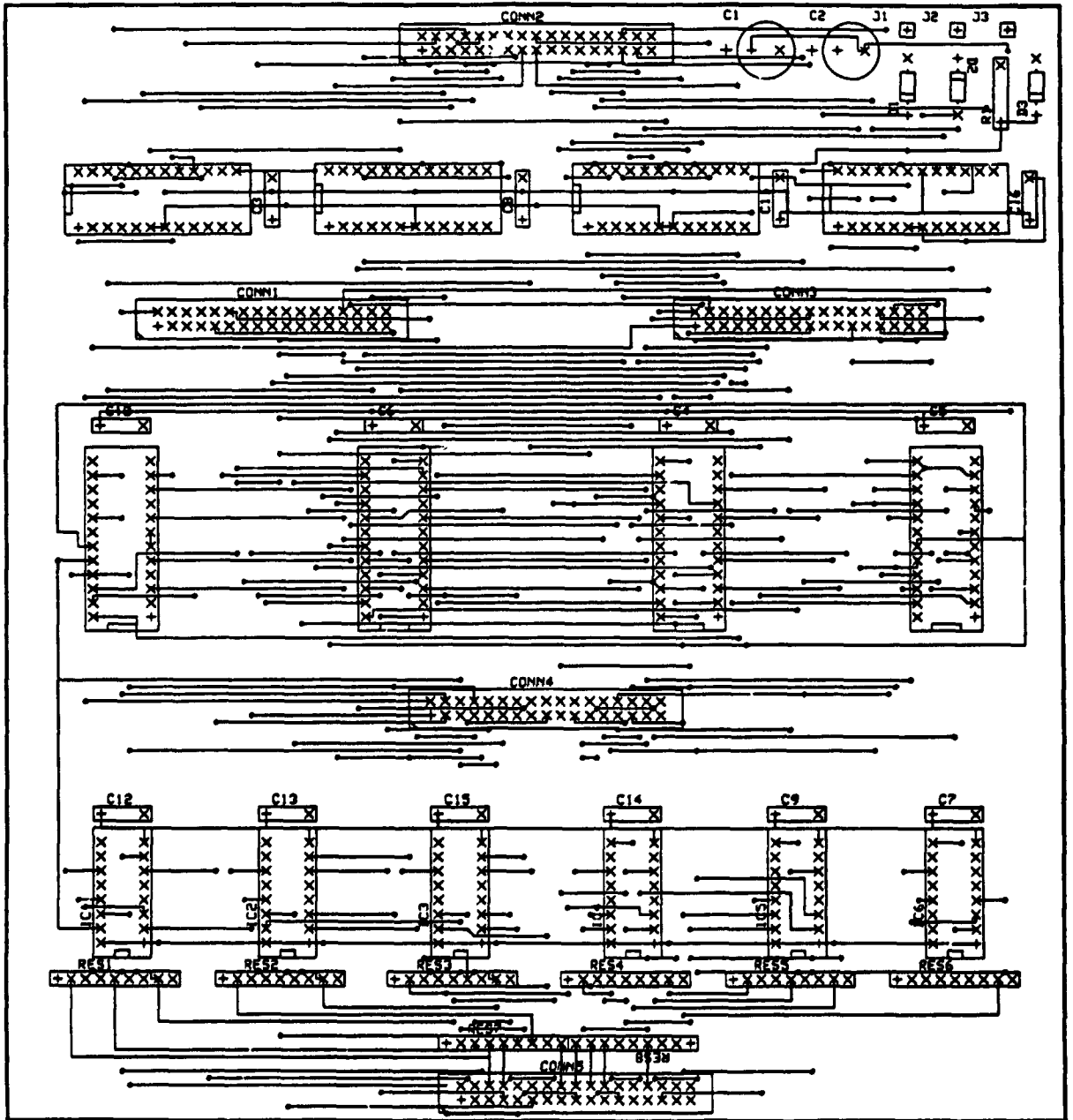

Fig.10. Board TANSY3 Layer 1

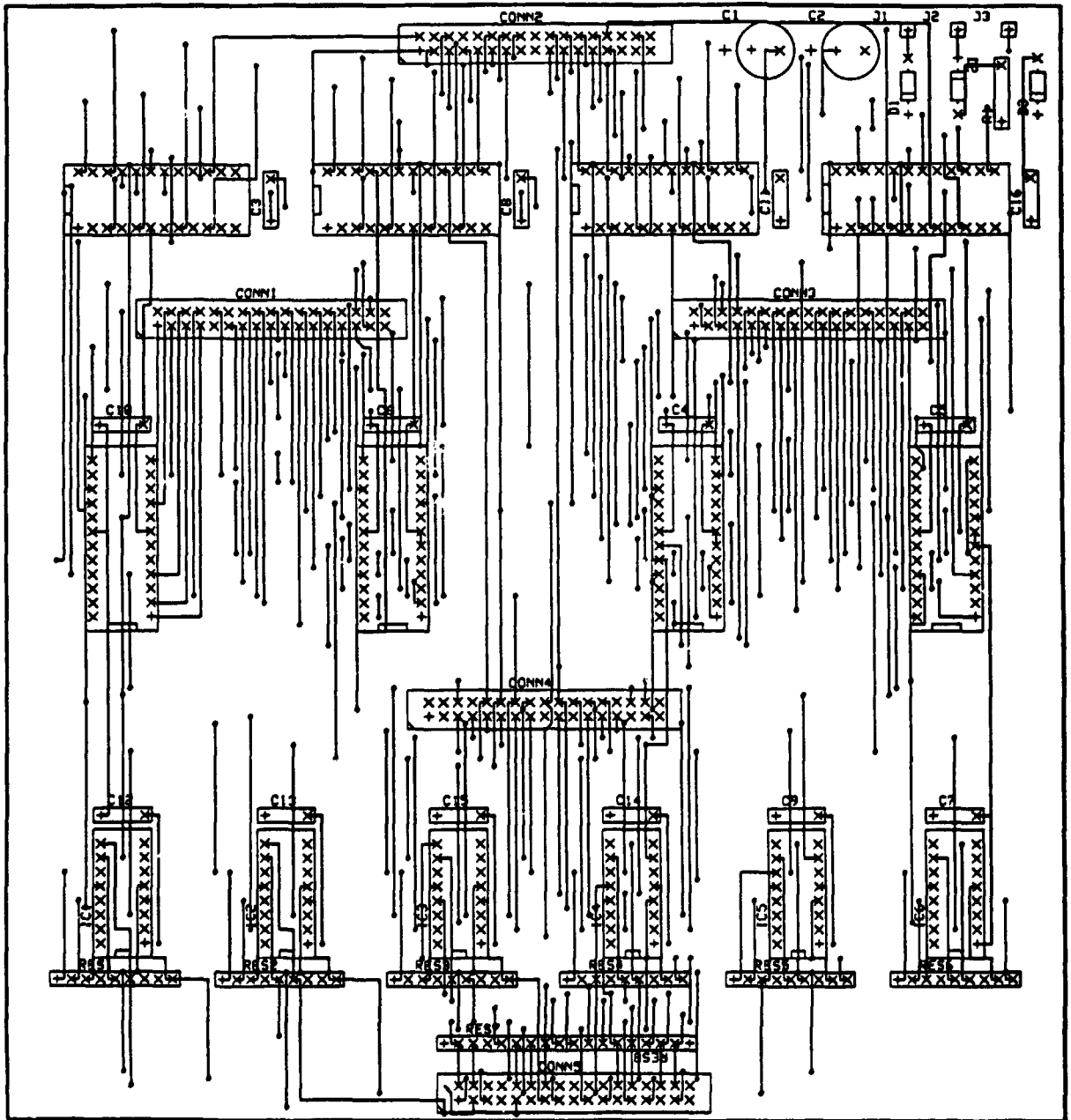

Fig.11. Board TANSY3 Layer 2

Table 1. Component List for Board TANSY2

Comp. #	Type	Value
C1	CF31	100nF
C2	CF31	100nF
C3	CF31	100nF
C4	CF31	100nF
C5	CF31	100nF
C6	CF31	100nF
C7	CF41	10nF
C8	CF41	
C9	CF41	390pF
C10	CF41	470pF
C11	CF41	100nF
C12	CF41	100nF
C13	CES24	1000μF
C14	CES24	1000μF
C15	CF41	680pF
C16	CF41	10nF
C17	CF41	10nF
D1	DIODE4	1N4148
D2	DIODE4	1N4148
D3	DIODE4	1N4148
D4	DIODE4	1N4148
D5	DIODE4	1N4148
D6	DIODE4	1N4148
D7	DIODE4	1N4148
D8	DIODE4	1N4148
D9	DIODE4	1N4148
D10	DIODE4	1N4148
D11	DIODE4	1N4148
D12	DIODE4	1N4148
D13	DIODE4	1N4148
D14	DIODE4	1N4148
D15	DIODE4	1N4148
D16	DIODE4	1N4148
D17	DIODE4	1N4148
D18	DIODE4	1N4148
D19	DIODE4	1N4148
D20	DIODE4	1N4148
D21	DIODE4	1N4148
D22	DIODE4	1N4148
D23	DIODE4	1N4148
D24	DIODE4	1N4148
D25	DIODE4	1N4148
D26	DIODE4	1N4148
D27	DIODE41	1N5400
D28	DIODE41	1N5400
IC1	F100114	F100114
IC2	F100104	F100104
IC3	F100102	F100102
IC4	F100125	F100125
IC5	MC10198	MC10198
IC6	MC10198	MC10198
IC7	MC10198	MC10198



Fan-Out Module CTH-RF-83

Comp. #	Type	Value
IC8	74HC14	74AC14
J1	LEMOPC	
J2	LEMOPC	
J3	LEMOPC	
J4	LEMOPC	
J5	LEMOPC	
J6	LEMOPC	
J7	LEMOPC	
J8	LEMOPC	
J9	LEMOPC	
J10	LEMOPC	
J11	LEMOPC	
J12	LEMOPC	
J13	LIST1	
J14	LIST1	
J15	LIST1	
J16	LIST1	
J17	LIST1	
J18	LIST1	
J19	LIST1	
J20	LIST1	
J21	LIST1	
K1	OUTPIN	
K2	OUTPIN	
K3	OUTPIN	
K4	OUTPIN	
P1	POT67W	10k
P2	POT67W	10k
P3	POT67W	10k
R1	RES4	22k
R2	RES4	560
R3	RES4	820
R4	RES4	820
R5	RES4	22k
R6	RES4	560
R7	RES4	820
R8	RES4	820
R9	RES4	22k
R10	RES4	560
R11	RES4	820
R12	RES4	820
R13	RES4	22k
R14	RES4	560
R15	RES4	820
R16	RES4	820
R17	RES4	47
R18	RES4	680
R19	RES4	33
R20	RES4	330
R21	RES4	110
R22	RES4	1k
R23	RES4	680
R24	RES4	330

Fan-Out Module CTH-RF-83

Comp. #	Type	Value
R25	RES4	330
R26	RES4	680
R27	RES4	820
R28	RES4	10
R29	RES4	10
R30	RES4	47
R31	RES4	680
R32	RES4	33
R33	RES4	330
R34	RES3	330
R35	RES3	330
RES1	SIL9	8*330
T1	NPN	2N3904
T2	NPN	2N3904
T3	NPN	2N3904
T4	NPN	2N3904
T5	NPN	2N3904
T6	NPN	2N3904
T7	PNP	2N3906
T8	PNP	2N3906
T9	PNP	2N3906
T10	PNP	2N3906
T11	PNP	2N3906
T12	PNP	2N3906

Table 2. Component List for Board TANSY3

Comp. #	Type	Value
C1	CF31	100nF
C2	CF31	100nF
C3	CF31	100nF
C4	CF31	100nF
C5	CF31	100nF
C6	CF31	100nF
C7	CF41	10nF
C8	CF41	
C9	CF41	390pF
C10	CF41	470pF
C11	CF41	100nF
C12	CF41	100nF
C13	CES24	1000μF
C14	CES24	1000μF
C15	CF41	680pF
C16	CF41	10nF
C17	CF41	10nF
D1	DIODE4	1N4148
D2	DIODE4	1N4148
D3	DIODE4	1N4148
D4	DIODE4	1N4148
D5	DIODE4	1N4148
D6	DIODE4	1N4148
D7	DIODE4	1N4148
D8	DIODE4	1N4148
D9	DIODE4	1N4148
D10	DIODE4	1N4148
D11	DIODE4	1N4148
D12	DIODE4	1N4148
D13	DIODE4	1N4148
D14	DIODE4	1N4148
D15	DIODE4	1N4148
D16	DIODE4	1N4148
D17	DIODE4	1N4148
D18	DIODE4	1N4148
D19	DIODE4	1N4148
D20	DIODE4	1N4148
D21	DIODE4	1N4148
D22	DIODE4	1N4148
D23	DIODE4	1N4148
D24	DIODE4	1N4148
D25	DIODE4	1N4148
D26	DIODE4	1N4148
D27	DIODE41	1N5400
D28	DIODE41	1N5400
IC1	F100114	F100114
IC2	F100104	F100104
IC3	F100102	F100102
IC4	F100125	F100125
IC5	MC10198	MC10198

## Fan-Out Module CTH-RF-83

Comp. #	Type	Value
IC6	MC10198	MC10198
IC7	MC10198	MC10198
IC8	74HC14	74AC14
J1	LEMOPC	
J2	LEMOPC	
J3	LEMOPC	
J4	LEMOPC	
J5	LEMOPC	
J6	LEMOPC	
J7	LEMOPC	
J8	LEMOPC	
J9	LEMOPC	
J10	LEMOPC	
J11	LEMOPC	
J12	LEMOPC	
J13	LIST1	
J14	LIST1	
J15	LIST1	
J16	LIST1	
J17	LIST1	
J18	LIST1	
J19	LIST1	
J20	LIST1	
J21	LIST1	
K1	OUTPIN	
K2	OUTPIN	
K3	OUTPIN	
K4	OUTPIN	
P1	POT67W	10k
P2	POT67W	10k
P3	POT67W	10k
R1	RES4	22k
R2	RES4	560
R3	RES4	820
R4	RES4	820
R5	RES4	22k
R6	RES4	560
R7	RES4	820
R8	RES4	820
R9	RES4	22k
R10	RES4	560
R11	RES4	820
R12	RES4	820
R13	RES4	22k
R14	RES4	560
R15	RES4	820
R16	RES4	820
R17	RES4	47
R18	RES4	680
R19	RES4	33
R20	RES4	330
R21	RES4	110
R22	RES4	1k

Fan-Out Module CTH-RF-83

Comp. #	Type	Value
R23	RES4	680
R24	RES4	330
R25	RES4	330
R26	RES4	680
R27	RES4	820
R28	RES4	10
R29	RES4	10
R30	RES4	47
R31	RES4	680
R32	RES4	330
R33	RES4	330
R34	RES3	330
R35	RES3	330
RES1	SIL9	8*330
T1	NPN	2N3904
T2	NPN	2N3904
T3	NPN	2N3904
T4	NPN	2N3904
T5	NPN	2N3904
T6	NPN	2N3904
T7	PNP	2N3906
T8	PNP	2N3906
T9	PNP	2N3906
T10	PNP	2N3906
T11	PNP	2N3906
T12	PNP	2N3906