

**Cold Test Facility for 1.8 m Superconducting  
Model Magnets at the SSC\***

A. LaBarge

Superconducting Super Collider Laboratory<sup>†</sup>  
2550 Beckleymeade Ave.  
Dallas, TX 75237

July 1993

**MASTER**

---

\*To be presented at the International Cryogenics Engineering Conference, July 12-14, Albuquerque, N.M.

<sup>†</sup>Operated by the Universities Research Association, Inc., for the U.S. Department of Energy under Contract No. DE-AC35-89ER40486.

*db*  
DISTRIBUTION OF THIS DOCUMENT IS UNLIMITED

## COLD TEST FACILITY FOR 1.8 M SUPERCONDUCTING MODEL MAGNETS AT THE SSCL

A. LaBarge

Superconducting Super Collider Laboratory\*  
2550 Beckleymeade Ave.  
Dallas, TX 75237

### INTRODUCTION

A new facility has been constructed to measure the characteristic features of superconducting model magnets and cable at cryogenic temperatures—a function which supports the design and development process for building full-scale accelerator magnets. There are multiple systems operating in concert to test the model magnets, namely: cryogenic, magnet power, data acquisition and system control.

A typical model magnet test includes the following items: (1) warm measurements of magnet coils, strain gauges and voltage taps; (2) hipot testing of insulation integrity; (3) cooling with liquid nitrogen and then liquid helium; (4) measuring quench current and magnetic field; (5) magnet warm-up.

While the magnet is being cooled to 4.22 K, the mechanical stress is monitored through strain gauges. Current is then ramped into the magnet until it reaches some maximum value and the magnet transitions from the superconducting state to the normal state. Normal-zone propagation is monitored using voltage taps on the magnet coils during this process, thus indicating where the transition began. The current ramp is usually repeated until a plateau current is reached, where the magnet has mechanically settled.

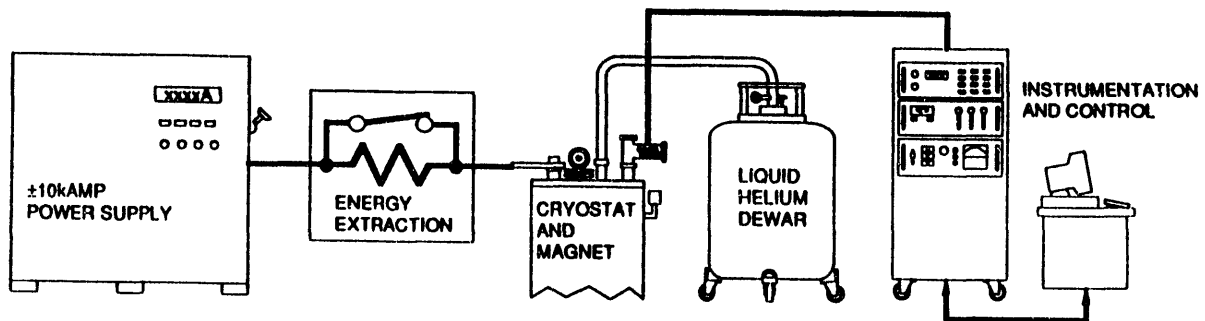

Figure 1. A simplified block diagram of the model magnet testing facility, illustrating current flow through the energy extract dump resistor, LHe supplied through portable 500 L dewars and the data acquisition and control system.

\*Operated by the Universities Research Association, Inc., for the U.S. Department of Energy under Contract No. DE-AC35-89ER40486.

Many variations on the current ramping sequence are used to study different phenomena associated with magnet performance, *e.g.* magnetization hysteresis, eddy current losses, cryogenic stability, etc.

A warm bore cryostat with a rotating coil is inserted in the magnet to measure field strength and homogeneity. These types of measurements yield multipole and current versus field data.

## CRYOGENIC SYSTEM

The testing vessel is an open mouth helium dewar designed for vertical testing of short dipole and quadrupole superconducting magnets. The nominal clear ID of the dewar is 711 mm except at the lambda plate support channel where the ID is 664 mm. The working depth below the Lambda plate is approximately 2400 mm and the overall height of the dewar to the top-plate is 3529 mm. The associated top-plate assembly includes a subcooler, Lambda plate and HE II heat exchanger to permit magnet operation over the temperature range from 4.5 K down to 1.8 K at 1.0 to 1.3 bar. The dewar is equipped with a liquid nitrogen-cooled shield to reduce the heat leak to liquid helium. The liquid nitrogen system terminates in an external keepful which automatically controls venting without release of liquid.

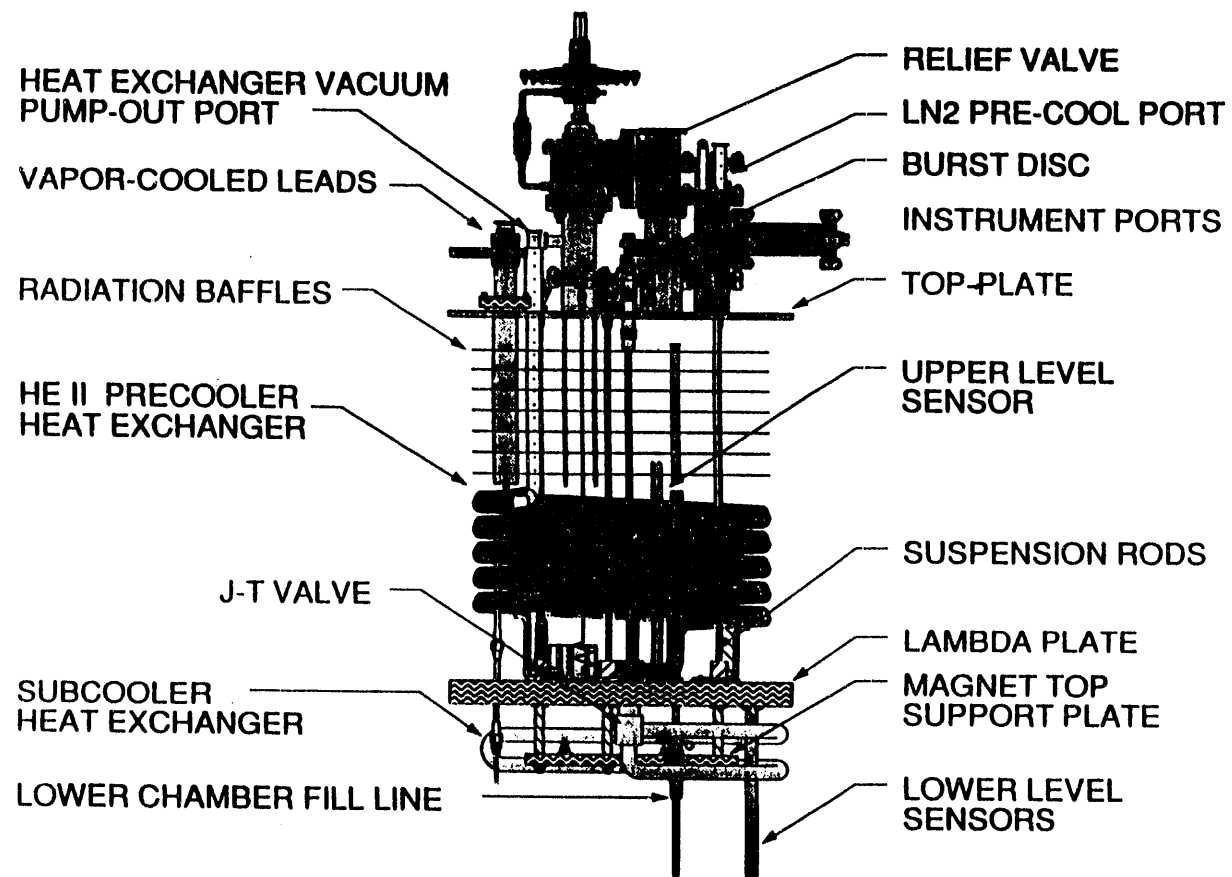

**Figure 2.** The top-plate assembly contains all of the active elements of the cryostat and provides an interface for the cryogenics and instrumentation. The magnet under test is suspended below the Lambda plate.

Additional features of the cryostat include a manual Joule-Thomson valve to control flow from the subcooler to the HE II heat exchanger, a vacuum pumping line for 10 to 12 Torr vapor from the superfluid heat exchanger, two superconducting liquid level gauges above and two below the Lambda plate, a Lambda plate relief device, and a capillary line for pressurization of the HE II volume.

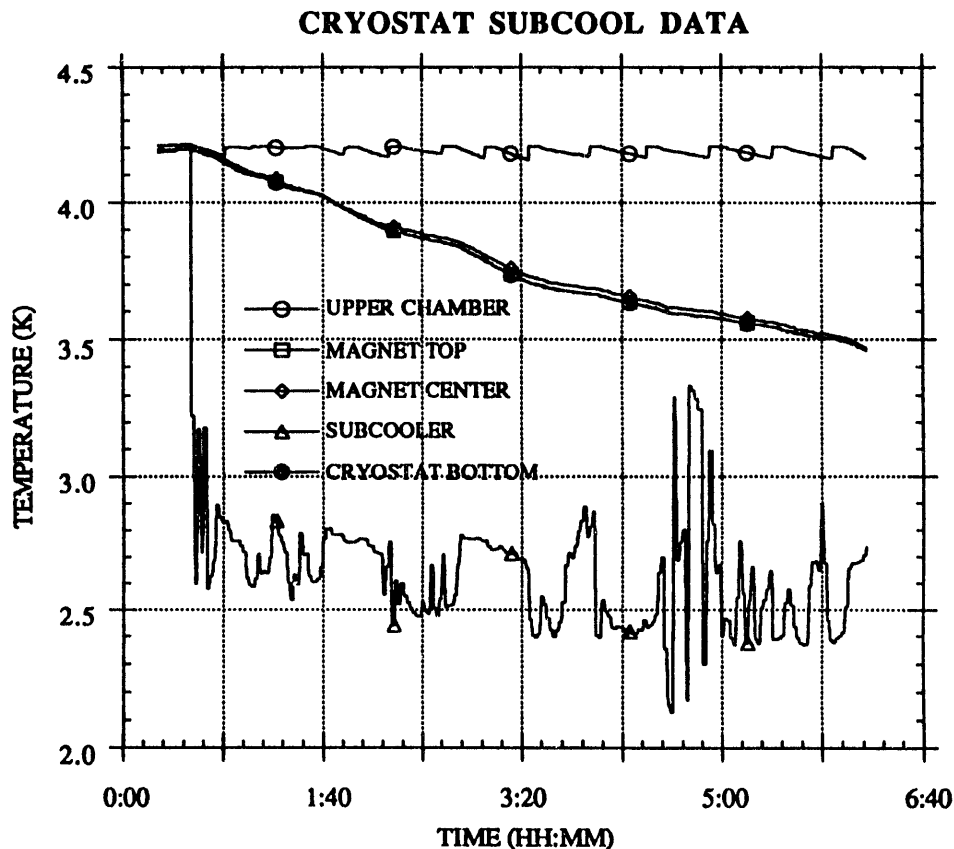

**Figure 3.** The subcooler was operated over a 6-hour period producing the data illustrated above, the 750 L volume of LHe below the Lambda plate was subcooled to 3.5 K.

## POWER SYSTEM

A Dynapower four quadrant  $\pm 10$  kA power supply is used to energize the model magnet. It is series connected to the dump resistor which provides 1 MJ of energy extraction. The  $\pm 10$  kA power supply has two six (6) pulse secondary silicon controlled rectifier (SCR) cycloconverters in series operating in a circulating current mode. The passive Prague filter with split-leg choke and active *ripple buckler* together provide excellent noise performance with a measured voltage ripple of less than 3.0 mV. Three primary taps are available on the transformer to configure the output voltage to  $\pm 6$  V,  $\pm 12$  V, and  $\pm 24$  V. The current is reduced to  $\pm 5$  kA at the  $\pm 24$  V setting.

Power supply stability and regulation is maintained by an ultra-stable zero flux current transducer (ZFCT) with temperature controlled burden resistor, digital-to-analog converter and summing amplifier. The ZFCT accounts for the 2 ppm stability and 50 ppm absolute accuracy.

Operating wave forms for either voltage or current are downloaded to the power supply's embedded controller through an IEEE-488 interface. This wave form is executed as a piece-wise linear curve. Each set-point is described by a final current or voltage value and an associated ramp rate. Access to the digital-to-analog converter is also possible for arbitrary wave form generation.

One rail of the power supply output is connected to the energy extraction circuit as illustrated below in figure 4. Ordinary operation of energizing the magnet bypasses the dump resistor by allowing current to flow through the active parallel SCR.

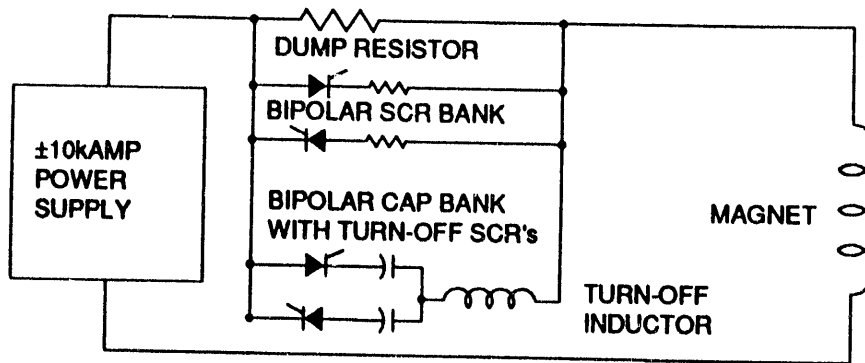

**Figure 4.** The  $\pm 10$  kA power supply is series connected to the magnet under test through an energy extraction dump resistor. Two sets of SCR's and capacitor banks are utilized for bipolar operation.

When the magnet transitions to normal state, the active SCRs are disabled by removing the gate drive signal. The SCRs will stop conducting when current stops flowing through the junction and the gate charge is removed. This is accomplished by discharging the associated capacitor bank into the magnet, which turns-off the active SCRs, thus allowing the energy stored in the magnet to dissipate through the dump resistor. During energy extraction the power supply reference is set to zero which causes the output to invert and assist the extraction. The power supply output may also be clamped by a set of bypass thyristors.

## DATA ACQUISITION AND CONTROL

The data acquisition and control system is comprised of the following instruments: (1) 256 channel voltage tap, (2) 96 channel strain gauge, (3) power supply, (4) cryogenic, (5) magnetic measurement. Each of these instruments is connected, via ethernet, to a SPARCstation 2 control console. Ethernet provides the principal data and control path for communication with each instrument. Data synchronization is handled at each instrument through an on-board time stamp module which is connected through a fiber optic cable to the master time stamp controller in the power supply instrument. Sampled data is stored locally at each instrument until the experimental run is finished. At this time the data is transferred to the SPARCserver 690MP for archive to the main database, Sybase.

Control software at each instrument consists of VxWorks, a real-time operating system, and application code for data acquisition and control. Network sockets are used to communicate back to the control console with data and status. At the control console, application software is running under SunOS UNIX with DataViews as the graphical user interface. PV~Wave is used to plot results to a postscript printer.

## Voltage Tap Instrument

The Analogic Data Acquisition Instrument (DAI) is a 256 channel transient signal recorder with a wide dynamic range and 13-bit resolution. Each channel is a low noise, floating, autoranging analog-to-digital converter which can digitize signals from  $\pm 5 \mu\text{V}$  to greater than  $\pm 1000$  V. A 16-bit word consisting of a two's complement 13-bit mantissa and a 3-bit exponent is produced for each sample. The digitizer sampling rate ranges from 1 kHz to 100 kHz and each channel has 1 Mbyte of buffer space allocated, thus 5.12 seconds of data may be recorded at 100 kHz. Each exponent value corresponds to seven (7) gain ranges, the full-scale ranges are as follows: (1) 9.76 mV, (2) 78.1 mV, (3) 0.625 V, (4) 5 V, (5) 40 V, (6) 320 V, (7) 2560 V. The resolution at the lowest gain range is  $2.3 \mu\text{V}$  and the system bandwidth is approximately -3 dB @ 25 kHz with a noise density less than  $30 \text{ nV}/(\text{Hz})^{1/2}$ .

The DAI contains a precision voltage source, which is used for channel calibration before each experimental run. The calibration coefficients are stored in each of the digitizers and used in real-time to compensate for channel offsets. Each set of 32 channels is funneled through a digital signal processor consisting of two (2) TMS320C30s, each capable of 33 million floating point operations per second.

## Strain Gauge Instrument

The strain gauge instrument provides 96 channels of precision 4-wire resistance measurements with continuous sampling at approximately 1 Hz. The illustration in Figure 5 outlines a typical set of seven strain gauge channels and their interconnection to the instrument. A 16-bit isolated analog-to-digital converter is used as a precision current source for a series of seven active and compensating strain gauges. The center of the current loop is a Vishay resistor with a temperature drift of 0.3 ppm/°C. This sense resistor is sampled along with the strain gauges as an accurate measure of the excitation current. Thermal offsets present in the interconnection cable, relays and FET multiplexers are significantly reduced by switching the source current and voltmeter terminals.

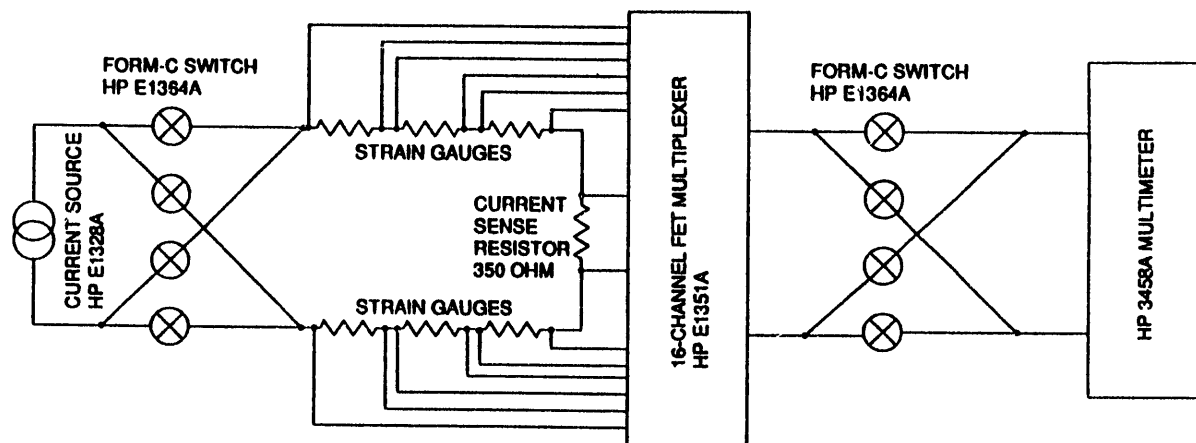

**Figure 5.** A functional diagram of the strain gauge instrument depicting the strain gauge current loop with the central current sense resistor.

Additionally, a precision resistor (traceable to NIST) is measured by each channel during a calibration cycle and the offsets are used for subsequent channel compensation.

## Power Supply and Cryostat Instruments

The power supply instrument is primarily responsible for accurately measuring the magnet voltage and current in addition to downloading wave forms to the  $\pm 10$  kA power supply. The HP 3458A 8 1/2 digit multimeter is used to measure magnet current from the ZFCT in the power supply, an additional meter is used to measure magnet voltage. Safety interlocks, data synchronization, and energy extraction are also managed from this instrument.

The cryostat instrument handles all temperature, pressure and mass flow measurements, including liquid level monitoring and a weighing pad for portable 500 L LHe dewars. The Lake Shore model 820 cryogenic thermometer is used to monitor carbon-glass and platinum temperature sensors. The MKS model 147B flow and pressure controller is used to monitor and control cryostat pressure and mass flow through the vapor-cooled current leads.

## Software Control System

The software control system may be segregated into six primary activities, namely: (1) Experiment Control, (2) Instrument Front Panel, (3) Embedded Controller, (4) Database and (5) Analysis. Illustrated below is a data flow diagram of the interactions between these activities.

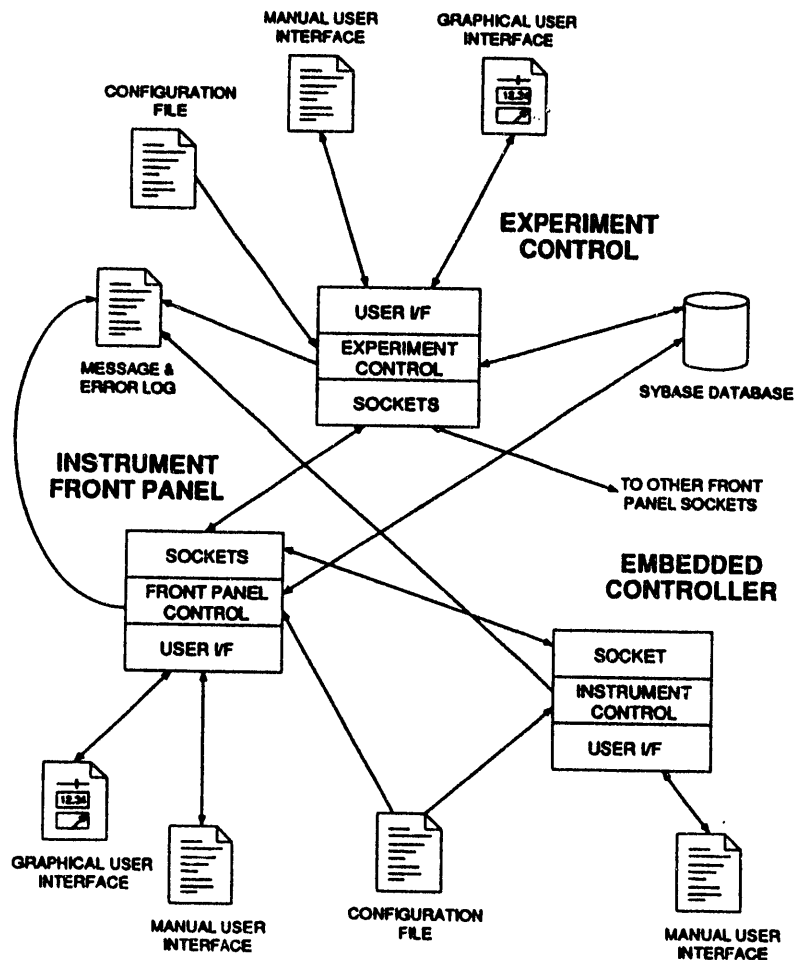

Figure 6. A data flow diagram illustrating the interactions between the various software tasks of the control system.

Experiment Control is responsible for time sequencing commands to each instrument during the course of an experiment and allowing the user to interact with the process. Additionally, it handles tightly coupled operations by coordinating commands based on instrument status.

Instrument Front Panel tasks directly communicate to their respective instrument via ethernet. This provides a graphical interface for the user to interact with the instrument. These tasks may run in a stand-alone mode allowing autonomous control of the instrument from a single workstation.

The Embedded Controller deals directly with the business of data acquisition. It is responsible for hardware setup, status monitoring, and short term data storage. This task is closest to the hardware and operates through a real-time multitasking executive.

Each magnet test is archived to an on-line database. Once the experimental run is complete, the data is collected from each instrument and stored in the database. Setup configuration, such as channel assignment and strain gauge calibration coefficients, are also stored. The database easily handles multiple user requests so data collection and analysis may operate concurrently. The database conforms to the ANSI standard for structured query language (SQL) transactions.

## RESULTS

Several representative data plots are illustrated below depicting typical analysis results from several model magnets.

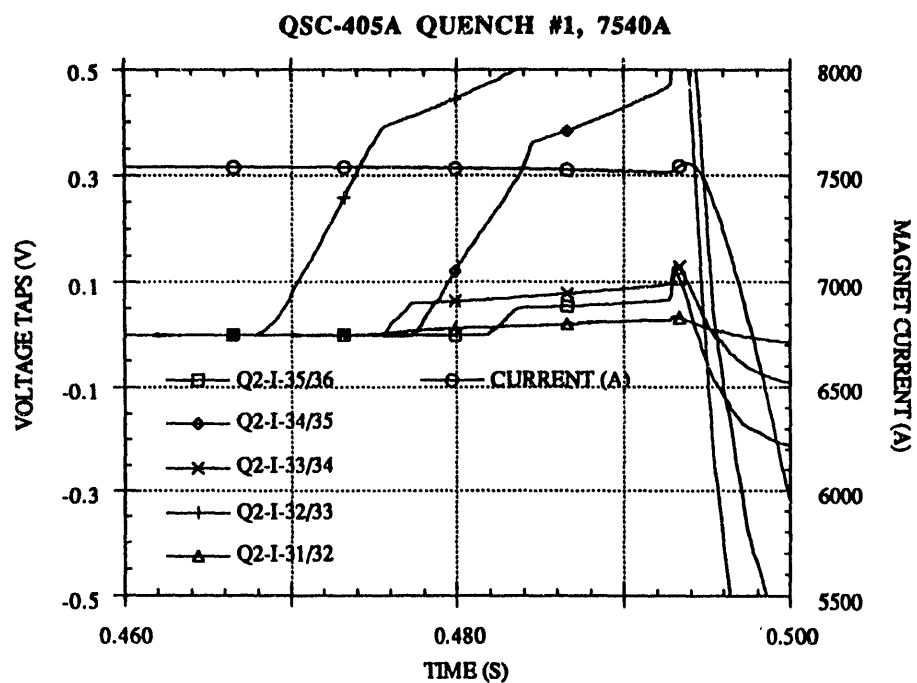

Figure 7. Voltage tap versus time plots provide identification of quench origin and propagation. Here, QSC-405A, begins normal state transition at Quadrant 2 of the inner coil between taps 32 and 33.

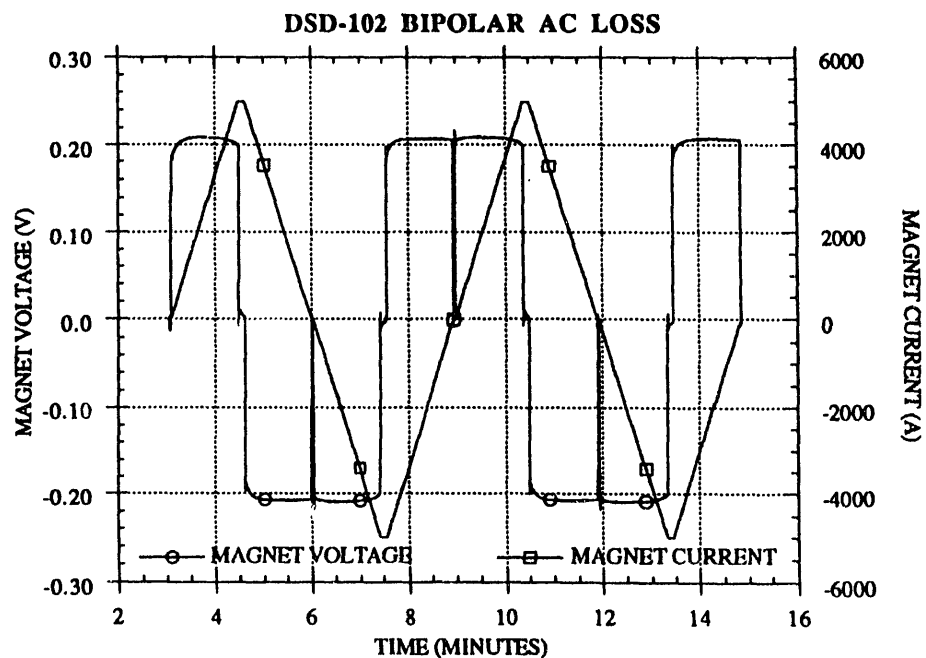

Figure 8. An AC Loss measurement of DSD-102 provides magnetization hysteresis and eddy current loss information. The power supply ramp is continuous through zero which allows true bipolar operation.



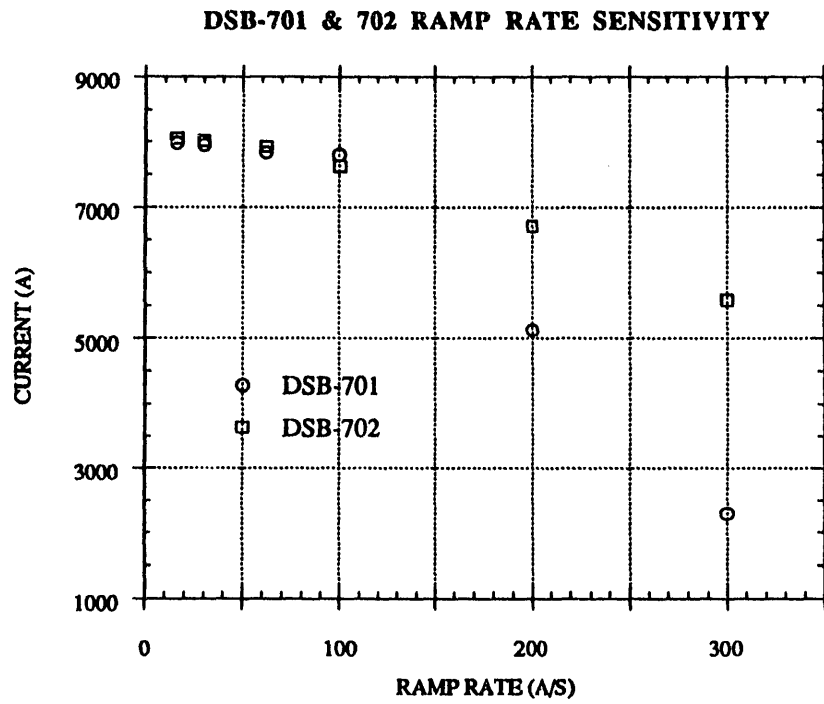

Figure 9. DSB-701 & 702 quench performance ramp rate dependence.

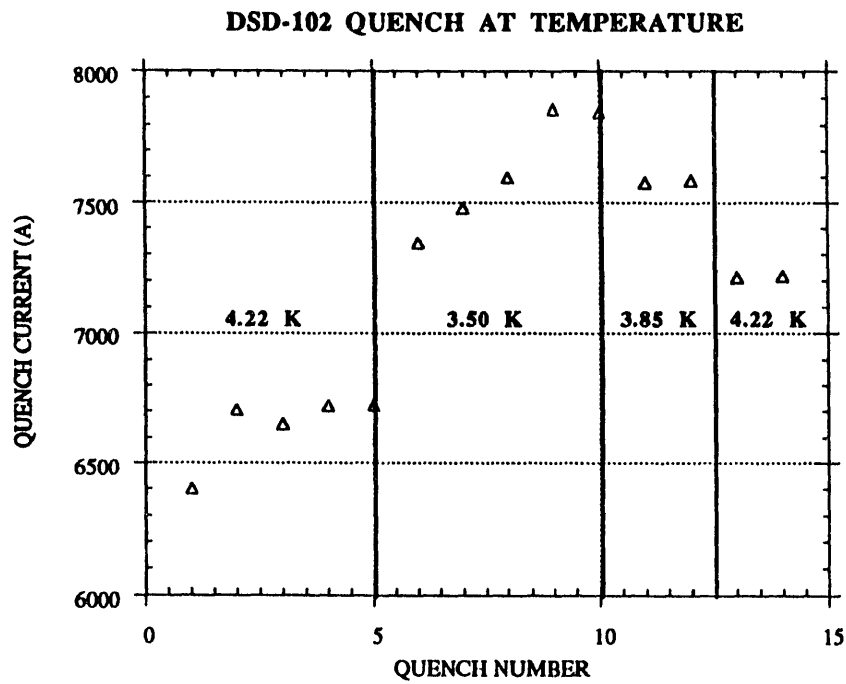

Figure 10. DSD-102 quench performance temperature dependence.

**END**

**DATE  
FILMED**

**10 / 13 / 93**

