

Distribution Category: Atomic,
Molecular, and Chemical Physics
(UC-411)

ARGONNE NATIONAL LABORATORY
9700 South Cass Avenue
Argonne, Illinois 60439

ANL/APS/TB-7
SLAC TN 93-5

Guide to Beamline Radiation Shielding Design at the Advanced Photon Source

by

N. Ipe, D. R. Haeffner, E. E. Alp, S. C. Davey, R. J. Dejus,
U. Hahn, B. Lai, K. J. Randall, and D. Shu

Experimental Facilities Division
Advanced Photon Source

November 1993

work sponsored by
U.S. DEPARTMENT OF ENERGY
Office of Energy Research

MASTER

DISTRIBUTION OF THIS DOCUMENT IS UNLIMITED *ds*

Acknowledgments

The authors would like to acknowledge the contributions of the following individuals:

APS: Glen Decker, Louis Emery, John Noonan, Tom Sanchez, Wenbing Yun, Diane Cheek, Kathy Krazuski, Bonnie Meyer, Susan Picologlou, Julie Wulf, and Cheryl Zidel,

SLAC: Ralph Nelson, James Liu, Helmut Wiedemann (SSRL), Melinda Ebron, Maxine Stokely, and Loretta Bleller,

CERN: Alberto Fasso,

and Dick McCall.

Nisy Ipe would like to thank Gopal Shenoy and Tunch Kuzay (both APS) for providing her with the opportunity of spending several months in the Experimental Facilities Division of the APS. She also expresses gratitude to Ken Kase (SLAC) for permitting her to work at the APS.

Table of Contents

List of Figures	vii
List of Tables	ix
1 Introduction.....	1
2 Design Criteria.....	3
2.1 DOE Requirements	3
2.1.1 <i>The Radiological Control Manual</i>	3
2.1.2 Dose Equivalent Limits	3
2.1.3 ALARA	3
2.2 Abnormal Situations	4
2.3 Interlocks.....	4
2.4 Local Shielding.....	5
2.5 Storage Ring Parameters.....	5
2.6 Choice of Insertion Device	6
2.7 Geometry of Shielding.....	6
3 Sources of Radiation	8
3.1 Radiation through the Ratchet Wall	8
3.2 Radiation through the Ratchet Wall Penetration	8
3.2.1 Interaction of Stored Beam with Ring Components.....	8
3.2.2 Gas Bremsstrahlung	9
3.2.3 Synchrotron Radiation	19
4 Shielding Recommendations	24
4.1 White Beam Hutches	24
4.1.1 Insertion Device.....	24
4.1.2 Bending Magnet	25
4.2 Monochromatic Beam Hutches.....	25
4.2.1 Insertion Device.....	26
4.2.2 Bending Magnet	26
4.3 Transport.....	26
4.3.1 White Beam	26
4.3.2 Monochromatic Beam.....	26
4.4 Shutters/Stops	27
Appendix A: Definition of Basic Radiological Quantities	A-1
A.1 Absorbed Dose.....	A-1
A.2 Dose Equivalent.....	A-1
A.3 Effective Dose Equivalent	A-1
Appendix B: APS Undulator Shielding.....	B-1

Appendix C: Radiation Environment of High-Energy Storage Rings..... C-1
 C.1 Electrons and Photons..... C-1
 C.2 Neutrons..... C-4
 C.3 Muons C-7
 C.4 Typical High-Energy Accelerator Shield C-8

Appendix D: Front End Collimation of Bremsstrahlung Beams..... D-1

List of Figures

Figure 1. Side view of a possible APS beamline.....	7
Figure 2. Gas bremsstrahlung from the APS insertion device straight section at 7.0 GeV.....	13
Figure 3. Photon dose equivalent rate one m from a 5-cm-long Cu target (radius of 2.54 cm) hit by the APS gas bremsstrahlung beam. The storage ring pressure is 1 atm, and the straight section length is 15 m.	14
Figure 4. Photon dose equivalent rate one m from a 5-cm-long W target (radius of 2.54 cm) hit by the APS gas bremsstrahlung beam. The storage ring pressure is 1 atm, and the straight section length is 15 m.	15
Figure 5. Top view of the FOE used in the sample calculations. Point A is the ratchet wall penetration.	16
Figure 6. The neutron yield from infinitely thick targets (per kW) as a function of electron beam energy. The calculation disregards target self shielding.	17
Figure 7. Comparison of PHOTON and PHOTON2 spectrums for the APS Wiggler A.	21
Figure B-1. The PHOTON bending magnet approximation compared to an undulator calculation.	B-1
Figure C-1. A schematic of an electromagnetic shower caused by an electron hitting a target.	C-2
Figure C-2. Photon cross section for Cu.....	C-6
Figure C-3. Typical high-energy electron accelerator shield.....	C-8
Figure D-1. The bremsstrahlung vertical ray tracing for the APS insertion device front end.....	D-2
Figure D-2. The bremsstrahlung horizontal ray tracing for the APS insertion device front end.....	D-3
Figure D-3. The bremsstrahlung vertical ray tracing for the APS bending magnet front end.	D-4
Figure D-4. The bremsstrahlung horizontal ray tracing for the APS bending magnet front end.	D-5

List of Tables

Table 1. Photon Calculation Parameters.....	22
Table B-1 Photon Calculation Parameters: Undulator Case.....	B-2
Table C-1 Radiological Parameters for Different Materials.....	C-5

1 Introduction

This document is intended to provide the necessary general information on radiation shielding for designers of beamlines at the Advanced Photon Source (APS). It is the result of numerous meetings by the APS Experimental Facilities Division Radiation Safety Committee (XFD/RSC) over a two year period. The current members of this committee are: Dean Haeffner (Chair), Ercan Alp, Steve Davey, Barry Lai, Kevin Randall, and Deming Shu. Both Nisy Ipe* and Ulrich Hahn† were visitors at the APS for several months and served on the XFD/RSC during their stays. Roger Dejus (APS) is a past member.

The most difficult part of this effort was defining appropriate radiation exposure scenarios. Lengthy discussions were held with the accelerator designers at the APS to help determine bremsstrahlung source locations, stored beam loss possibilities, injection loss ramifications, et cetera. A concerted effort was made to learn as much as possible from the experience of operating synchrotron sources. Experts on the simulation of bremsstrahlung photon-target interactions were consulted. The result of this considerable effort is probably the most comprehensive preoperation study of radiation safety ever conducted for a dedicated synchrotron facility.

Most of the XFD/RSC members are primarily engaged in the design of beamlines for the APS. It is hoped that by having such membership, the user's perspective was kept in mind throughout the process. Certainly, issues pertaining to these beamlines have elucidated problems that will be common to other beamlines on the APS floor. On the other hand, the addition of Nisy Ipe (who was on contract from SLAC for the duration of this study) gave the perspective and technical expertise of someone who has dealt with radiation safety at a high-energy Department of Energy (DOE) accelerator facility.

* Present address: Radiation Physics Department, Stanford Linear Accelerator Center (SLAC), Stanford, CA 94309.

† Present address: Hamburger Synchrotronstrahlungslabor (HASYLAB), Deutschen Elektronen-Synchrotron (DESY), Notkestrasse 85, D-2000 Hamburg 52, Germany.

This document is concerned with the general requirements for radiation shielding common to most APS users. These include shielding specifications for hutches, transport, stops, and shutters for both white and monochromatic beams. For brevity, only the results of calculations are given in most cases.

So-called "special situations" are not covered. These include beamlines with white beam mirrors for low-pass energy filters ("pink beams"), extremely wide band-pass monochromators (multilayers), or novel insertion devices. These topics are dependent on beamline layout and, as such, are not easily generalized. Also, many examples are given for "typical" hutches or other beamline components. If a user has components that differ greatly from those described, particular care should be taken in following these guidelines. Users with questions on specific special situations should address them to the APS User Technical Interface.

Also, this document does not cover specifics on hutch, transport, shutter, and stop designs. Issues such as how to join hutch panels, floor-wall interfaces, cable feed-throughs, and how to integrate shielding into transport are covered in the *APS Beamline Standard Components Handbook*.¹ It is a "living document" and as such reflects the improvements in component design that are ongoing.

This document has the following content. First, the design criteria will be given. This includes descriptions of some of the pertinent DOE regulations and policies, as well as brief discussions of abnormal situations, interlocks, local shielding, and storage ring parameters. Then, the various sources of radiation on the experimental floor will be discussed, and the methods used to calculate the shielding will be explained (along with some sample calculations). Finally, the shielding recommendations for different situations will be given and discussed.

¹U. Hahn, D. Shu, and T. Kuzay, *APS Beamline Standard Components Handbook*, Version 1.3, ANL/APS/LS-187 (1993). This document is periodically updated. The most current version should be used.

2 Design Criteria

2.1 DOE Requirements

2.1.1 The *Radiological Control Manual*

Argonne National Laboratory (ANL), and hence the APS, is a Department of Energy (DOE) facility and as such is subject to all DOE requirements. In recent years, the DOE has placed greater emphasis on safety, and this emphasis will be reflected in many ways in the Experiment Hall of the APS.

For DOE facilities the primary document on radiation safety is the *Radiological Control Manual (RadCon Manual)*.² It is a general document that specifies the requirements for many aspects of radiation safety including radiological standards, conduct of work, radioactive materials, support organizations, training, and record keeping. Where applicable, it will be used in the discussion that follows. In situations where no guidance is given by the *RadCon Manual*, the rationale that was used will be explicitly stated.

2.1.2 Dose Equivalent Limits

The *RadCon Manual* requires that new facilities be designed so that the annual integrated dose equivalent received by an individual be no more than 500 mrem.³ (For definitions of basic radiation safety units see Appendix A. *) With the assumption of a 2000-hour working year, this becomes a dose equivalent rate of 0.25 mrem/hr. The value of 0.25 mrem/hr will be used as the criterion to be met throughout this document unless otherwise noted.

2.1.3 ALARA

The *RadCon Manual* also requires the establishment of an ALARA program to guide the operation and design of radiation producing facilities at ANL.

²*Radiological Control Manual*, DOE N5480.6, U. S. Department of Energy, June 1992.

³*Radiological Control Manual*, Section 128.1.a., page 1-15.

* The DOE recommends the use of SI units in documents. This policy will be followed in this document, with the exception of units for radiation dose and dose equivalent. Both the *RadCon Manual* and ANL ESH training refer to dose equivalent values in mrem. Conversions to Sieverts are given in Appendix A.

ALARA stands for as low as reasonably achievable. ALARA should be considered a process by which the health risk to the individual is kept as low as is reasonably feasible. Implementation of this concept is the responsibility of all ANL employees and guests, and it must be used as a guiding concept during design.

Of course, the word "reasonably" in ALARA is somewhat subjective. To quote the *RadCon Manual*, "There is considerable leeway in determining how far is reasonable."⁴ It should be understood that this is not a draconian policy to make all radiation facilities impossible to design and operate, but rather a policy to achieve the best possible ratio of benefit to risk.

When calculating radiation shielding for personnel safety, a conservative approach should always be used. However, increasing the shielding arbitrarily can make design of experimental beamlines extremely difficult and prohibitively expensive while adding no additional safety benefit. During this study, an effort was made to keep the calculations as accurate as possible and to then add the appropriate safety factor.

2.2 Abnormal Situations

A somewhat difficult guideline to establish is the amount of radiation a worker can receive in an "abnormal" situation. Here, this is defined as an event whose occurrence is not a part of routine operations but is nonetheless believed to be possible. The *RadCon Manual* provides no guidance on this point. Therefore, the APS has established a design guideline that no single occurrence shall exceed 100 mrem (1/5 the annual dose equivalent). The time duration and resulting dose equivalent rate have to be examined on a case-by-case basis. Events that are found to occur routinely will require additional shielding steps to reduce the resulting exposure to acceptable levels.

2.3 Interlocks

The interlock system at the APS will monitor many situations that relate to radiation shielding. This is not the subject of this report and will not be cov-

⁴*Radiological Control Manual*, Section 138, paragraph 1, page 1-22.

ered here. However, note that there are two levels of interlock safety systems: personnel and equipment. The limitation of dose by the personnel safety system will be used when appropriate. The equipment safety system will not be considered as a means to reduce radiation exposure.

2.4 Local Shielding

When a potential radiation source is well known and limited in extent, it may be appropriate for local shielding to be used. Here, local shielding is shielding specific to a particular problem (e.g., the shielding around the bremsstrahlung stop) and not shielding that is general in concept (e.g., a hutch). It may be prudent in some circumstances to examine a situation under operating conditions and add local shielding if the radiation dose is too high. This should normally be done during commissioning.

All safety shielding (local or otherwise) is subject to administrative control. These controls must ensure that no beamline user can remove the shielding while the beamline is operational. Local shielding must be an integral part of the beamline's safety system. Details of local shielding design and implementation will have to be worked out on a case-by-case basis.

2.5 Storage Ring Parameters

The expected operating conditions of the APS storage ring are 7.0-GeV ring energy and 100-mA positron current. To increase operational reliability, the components of the storage ring have been designed to withstand 7.0 GeV and 300 mA. With these design parameters, the storage ring components should also be able to operate reliably at 7.5 GeV and 200 mA, or 7.7 GeV and 100 mA. If it is decided at a later date to run the ring at these higher values (in energy or current), it is undesirable to retrofit shielding for structures such as hutches. Hence, it was decided to make the shielding calculations at the operating conditions that would provide for the worst case. For synchrotron radiation, the worst case is 7.5 GeV and 200 mA. For gas bremsstrahlung radiation calculations, it is 7.0 GeV and 300 mA. Any operations at 7.7 GeV and 100 mA will probably be for machine studies only. During such studies, user activities on the experimental floor may be restricted (at least until a complete radiation survey has been made).

2.6 Choice of Insertion Device

All of the shielding calculations for insertion device (ID) beamlines have been done for APS Wiggler A with a minimum gap of 2.1 cm.⁵ It provides the most significant radiation risk among the currently planned IDs due to its relatively high critical energy (37.4 keV at 7.5-GeV ring energy).

Having shielding for Wiggler A ensures that a user initially using only an undulator may switch to (or add in tandem) a Wiggler A. It is best not to have to retrofit or construct a new hutch once a sector has been in operation. Not only are extra costs incurred from the hutch construction, but the disruption to the user and his neighbors by heavy construction activities is best avoided. A slightly heavier hutch, if constructed at the outset, has only a marginal impact on cost. (Another factor, discussed below, is that secondary gas bremsstrahlung tends to dominate certain aspects of the white beam shielding for IDs. This radiation is independent of the type of insertion device.)

Of course, any move to an insertion device with significantly greater radiation risk than Wiggler A will have to be evaluated for potential shielding problems. For comparison, the calculated shielding for the APS Undulator A is given in Appendix B.

2.7 Geometry of Shielding

In calculations of shielding, the distance from the scatterer to the shield plays a significant role. In general, the smaller the hutch, the greater the radiation through its walls and roof. For the calculations used in this study, rather small hutches were taken as models so as to represent worst-case situations. Any prospective hutch that has dimensions significantly smaller than those used in a particular calculation must be examined to see if the calculations are still valid. The same would hold for any hutch with an unconventional geometry. Figure 1 shows a schematic of a possible APS beamline.

⁵B. Lai, A. Khounsary, and E. Gluskin, "Wiggler A Characteristics and Specifications," ANL/APS/TB-11, Argonne National Laboratory (1993).

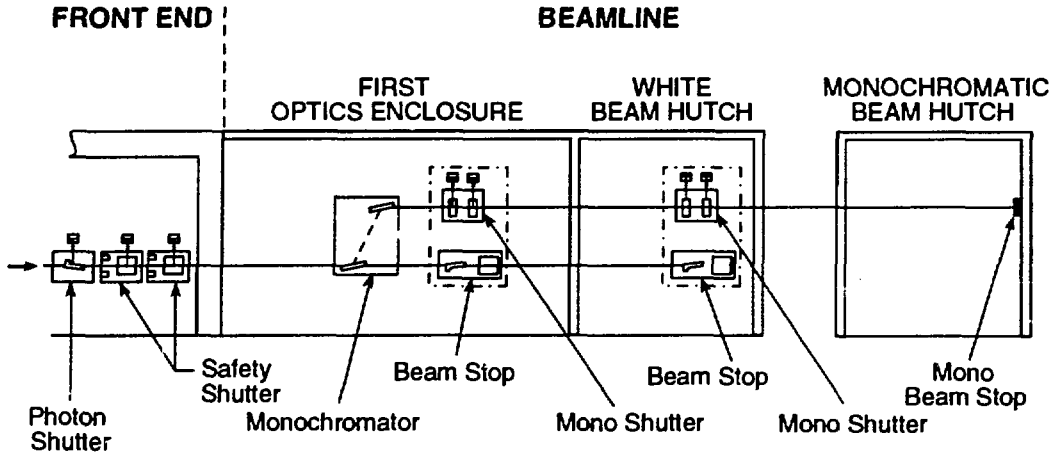

Figure 1. Side view of a possible APS beamline.

3 Sources of Radiation

The radiation present on the experimental floor can be separated into sources that come through the ratchet wall penetration and those that come through the ratchet wall itself. Appendix C contains a general discussion of the radiation environment of high-energy accelerators and storage rings.

3.1 Radiation through the Ratchet Wall

In the process of operating the accelerators and storage ring, as well as producing the desired synchrotron radiation, there is considerable generation of other radiation behind the ratchet wall. The shielding for this parasitic radiation is the responsibility of the Accelerator Systems Division of the APS. During the commissioning of the storage ring, surveys will be made to determine if any "hot spots" exist, and, if so, local shielding will be employed to reduce the dose rates to acceptable levels. The dose to a user on the Experiment Hall floor by radiation through the ratchet wall is intended to be negligible. The design of the shielding for the storage ring and other accelerator systems is covered in a previous report.⁶

3.2 Radiation through the Ratchet Wall Penetration

The radiation through the ratchet wall penetration falls into the following categories:

- Radiation from positron beam hitting storage ring components
- Gas bremsstrahlung
- Synchrotron radiation

These sources will now be considered in turn.

3.2.1 Interaction of Stored Beam with Ring Components

If the stored positron beam collides with any storage ring component, a bremsstrahlung shower will be produced. The most likely place for this to

⁶H. J. Moe, "Advanced Photon Source: Radiological Design Considerations," ANL/APS/LS-141 Revised, Argonne National Laboratory (1991).

happen is the transition piece from the rest of the storage ring to an ID vacuum chamber. Computer simulations used to follow the shower components indicate that only a small portion of this radiation makes it through the ratchet wall penetration. In addition, ray-tracing results have been used to design a series of collimators for the front end to severely limit the line of sight through the ratchet wall penetration. These collimators allow only radiation scattered very nearly along the beam path to exit onto the experimental floor. Additional information on these collimators is given in Appendix D. It is believed that the beamline shielding present to account for other radiation sources will be more than sufficient to stop the radiation from beam losses in storage ring components.

Initial operations at the APS will require that the beamline safety shutters (located inside the ratchet wall) be closed during injection. The closed shutters will keep any radiation that might come through the ratchet wall penetration behind the ratchet wall. A safety shutter consists of two (for redundancy) 30-cm tungsten blocks.⁷ The radiation dose through this amount of tungsten should be negligible.

If the APS at some point begins operating in a "Top Off" mode, in which the safety shutters are left open, the additional radiation due to this mode of operation will be addressed. Preliminary analysis indicates that it is not expected to be a problem. Studies are continuing, but a definitive answer will probably not be known until machine studies can be carried out on the operating storage ring.

3.2.2 Gas Bremsstrahlung

3.2.2.1 General Discussion

Gas bremsstrahlung is produced by the interaction of the storage ring positron (or electron) beam with residual gas molecules in the ring vacuum chamber. Such interactions are one of the sources of stored beam losses that result in beam decay. Gas bremsstrahlung interactions take place all around

⁷D. Shu, T. Sanchez, and T. Kuzay, "An Integrated Bremsstrahlung Safety Shutter and Collimator Designed for the APS Front End Operating in the Top-up Mode," ANL/APS/LS-192, Argonne National Laboratory (1992).

the storage ring, but are a particular problem in the straight sections for the IDs. Gas bremsstrahlung is produced in a very narrow beam ($1/\gamma$, 73 μ rad for 7 GeV) that sums for the entire section length. The APS ID straight sections are 15 m in length. (The straight section length is not the same as the maximum ID length.)

The radiation dose equivalent rate, *DER*, in the forward direction due to the direct gas bremsstrahlung beam is proportional to

$$DER \propto \frac{E_0^{2.67} i p l}{d(l+d)}, \quad [1]$$

where E_0 is the storage ring energy, i is the storage ring current, p is the storage ring pressure, l is the length of the effective straight section, and d is the distance from the end of straight section to the observation point.⁸ The spectral distribution of this beam is roughly proportional to the inverse of the photon energy going to 0 at E_0 .

3.2.2.2 Effect of Vacuum

From Eq. [1], it is seen that the gas bremsstrahlung radiation is proportional to the ring vacuum. Several factors lead to some uncertainty as to what value of ring vacuum should be used in the shielding calculations. First, if the storage ring is run at a relatively poor vacuum, the level of radiation present from gas interactions will be higher. Second, the actual vacuum in the narrow straight sections of the ID chambers may be somewhat worse than the ring vacuum as a whole. Finally, the use of a positrons (as opposed to electrons) may significantly reduce gas-beam interactions due to the repulsive force exerted by the positron beam on the positively charged gas ions.

It was assumed for calculation purposes that normal APS operating vacuum would be 10^{-9} Torr. If the storage ring is operated for a significant period of time at a poorer vacuum, radiation surveys will be made to determine radiation levels near the first optic enclosures (FOEs). If these levels are too high,

⁸A. Ferrari, M. Pelliccioni, and P. R. Sala, "Estimate of Fluence Rate and Absorbed Dose Rate Due to Gas Bremsstrahlung from Electron Storage Rings," LNF-93/016 P, INFN, Frascati, Italy (1993).

access will be limited, and, if deemed prudent, additional local shielding may have to be added.

One accident scenario is the venting of a straight section completely to atmosphere. This scenario was considered to be a maximum credible accident in a study for the NSLS.⁹ This is a complicated situation, and a rigorous calculation is difficult. The NSLS study concluded that, in a long straight section, the residual gas bremsstrahlung dose for one year should be roughly equivalent to a single vacuum loss event. An effort is being made to determine the radiation levels from such an event at the APS. Until this study is completed, the conservative assumptions used to determine the residual gas bremsstrahlung shielding are assumed to be adequate for such an accident.

3.2.2.3 Secondary Bremsstrahlung Scattering

The difficult problem with gas-positron interactions is not the gas bremsstrahlung beam itself; it can be stopped by an adequate bremsstrahlung stop. A more difficult problem to quantify is the scatter from all the components that the primary beam strikes. Such components include windows, filters, slits, monochromators, mirrors, and stops. These vary with each beamline and can change as a function of time (e.g., the monochromator). The scattering from these components will be referred to as secondary gas bremsstrahlung in this document.

The secondary gas bremsstrahlung radiation consists of neutrons as well as photons. The lead generally used to shield for photons will not effectively reduce neutron dose, so additional steps must be taken. The dose equivalent design limit of 0.25 mrem/hr applies to all radiation, so the sum of the dose equivalents from the photons and neutrons must be less than this value.

To calculate the secondary bremsstrahlung scattering, the EGS4 computer program was used with a special user code written at SLAC.¹⁰ The code uses

⁹W. Thomlinson, R. Watson, and L. Blumberg, NSLS Bulletin 82-2 (1982).

¹⁰W. R. Nelson and J. C. Liu, private communication.

the standard cylinder-slab geometry (described in the EGS4 manual¹¹) and calculates the following

- energy-angle distribution of fluence and absorbed dose equivalent on a scoring sphere surrounding a secondary target downstream of a gas bremsstrahlung source,
- output spectrum of photons from the target into various angular intervals, and
- yield of photo neutrons produced in the target.

It is not feasible to determine the scattering from all possible targets in the FOE or white beam hutches. Materials can change (e.g., new monochromator crystals), and the geometry of elements is not fixed (e.g., variable Bragg angles for crystals, position of slits). Hence, it is necessary to choose a representative target that will give doses of the highest likely magnitude.

The EGS4 program was used to generate a bremsstrahlung beam onto targets of various elements and geometry. The primary beam was generated with an E_0 of 7 GeV, l of 15 m, i of 1 A, and p of 1 atm. (The results were later scaled to appropriate ring current and pressure.) Figure 2 shows the *DER* from the primary gas bremsstrahlung beam before it strikes the target 24.6 m downstream of the center of the ID straight section.

Figures 3 and 4 show the results when 5-cm-long targets of copper and tungsten, respectively, are struck by this beam. After comparison of these and results from other targets, the 5-cm copper block was chosen to be the representative target.

If a target is struck at glancing angle, such as in the case of an x-ray mirror, the results calculated for the representative target may not provide a reliable estimate. A calculation has been made for a 90-cm-long Cu target inclined 1.25° from the incident beam. The target was facing towards the lateral wall. The *DER* at the lateral wall, 90° from the incident beam, was an order of magnitude higher than the *DER* for the representative normal incidence target.¹² Further calculations of glancing-angle scattering are being carried

¹¹W. R. Nelson, H. Hirayama, D. W. O. Rogers, "The EGS4 Code System," SLAC Report 265, Stanford Linear Accelerator Center (1985).

¹²N. Ipe, private communication.

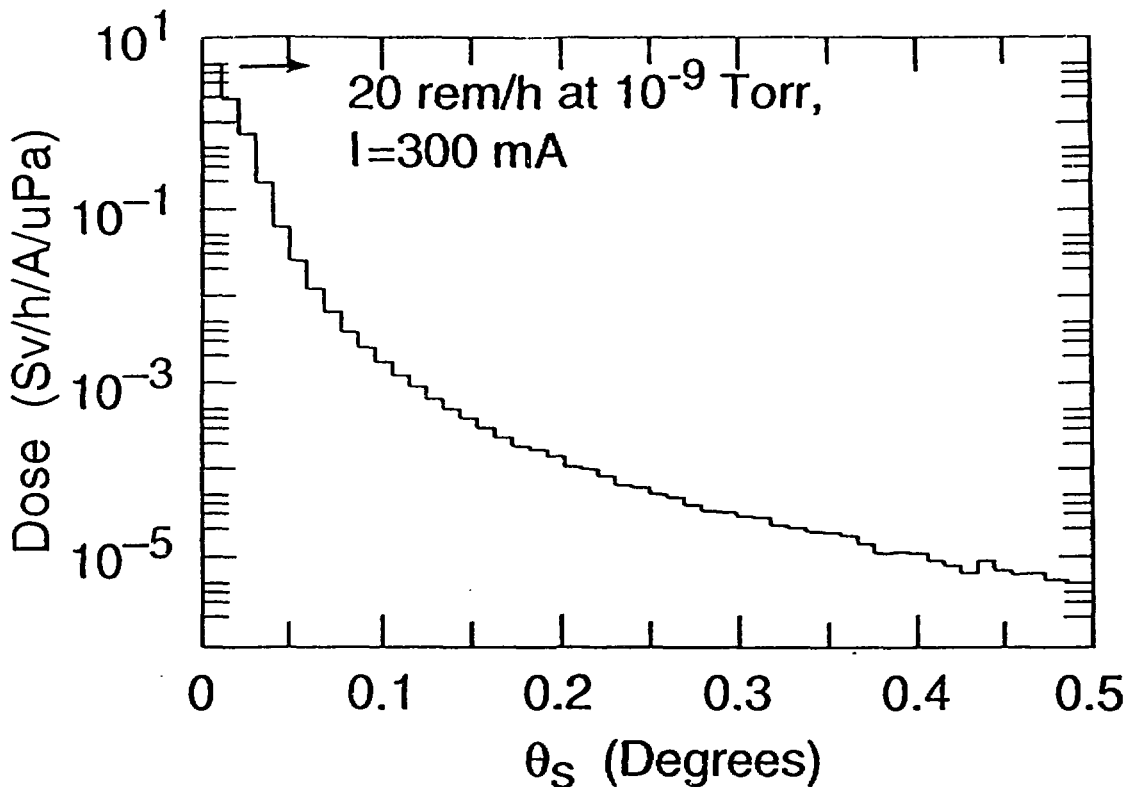

Figure 2. Gas bremsstrahlung from the APS insertion device straight section at 7.0 GeV.

out. Local shielding may be necessary for horizontal reflecting mirrors and other glancing angle components.

3.2.2.4 Shielding Determination

The appropriate shielding for secondary gas bremsstrahlung is calculated as follows:

1. Calculate the angle from the target to the point of interest.
2. Read the photon *DER* for that angle from the appropriate figure.
3. Convert the photon *DER* to appropriate values for the APS vacuum and current conditions.
4. Correct the photon *DER* for the distance to the shielding point.
5. Determine the *DER* for neutrons.
6. Determine the appropriate shielding for the combination of photon and neutron *DER*.

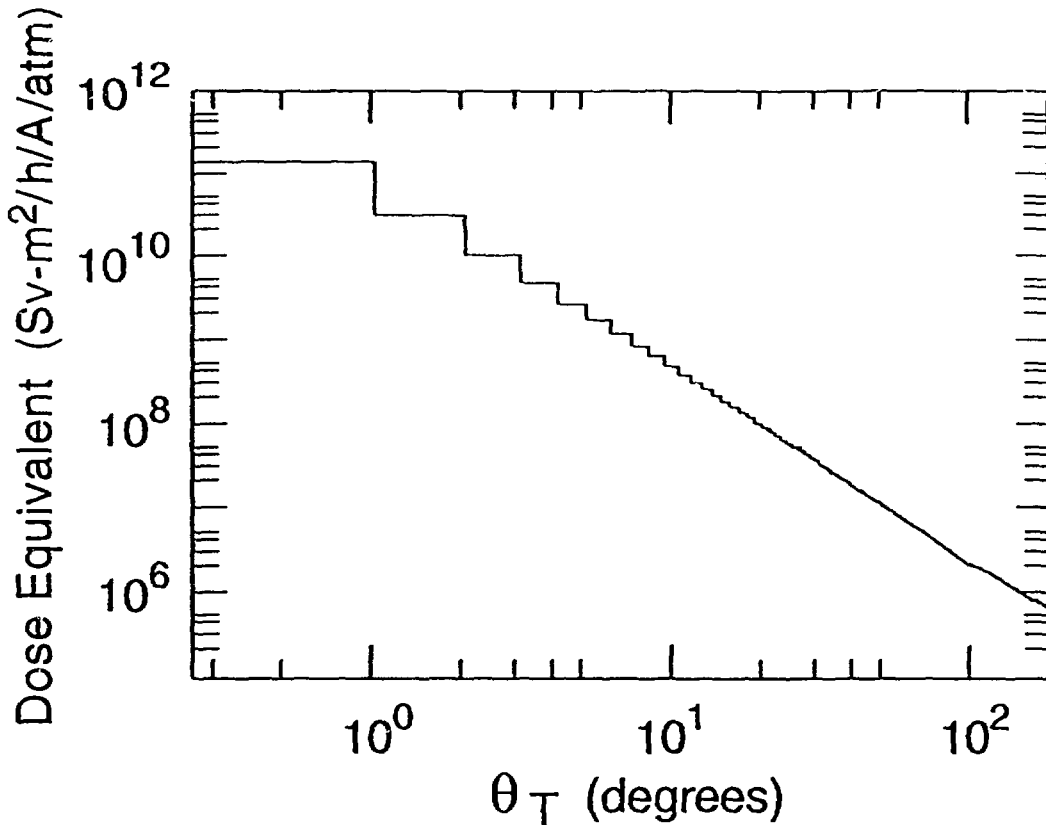

Figure 3. Photon dose equivalent rate one m from a 5-cm-long Cu target (radius of 2.54 cm) hit by the APS gas bremsstrahlung beam. The storage ring pressure is 1 atm, and the straight section length is 15 m.

A schematic of an APS FOE is shown in Figure 5. Due to space constraints on the experimental floor, most user FOEs will probably closely resemble this example. This hutch is 7.7 m along the beam (*AB*) and 1.2 m from the beam to the lateral wall (*BC*) (the other side is the ratchet wall). The following example shows how the shielding due to secondary gas bremsstrahlung can be calculated.

In the hutch shown in Figure 5, point *D* is the farthest point upstream where a scatterer (such as a beam shutter) can be placed. A bremsstrahlung stop is placed at point *G*, 6.9 m downstream of *D*. The stop is a tungsten block 30 cm along the beam and 24 cm transverse to the beam. The first point of concern is the lowest angle point on the back wall not shadowed by the stop (call this point *E*). The corresponding angle for scatter from *D* to this point is

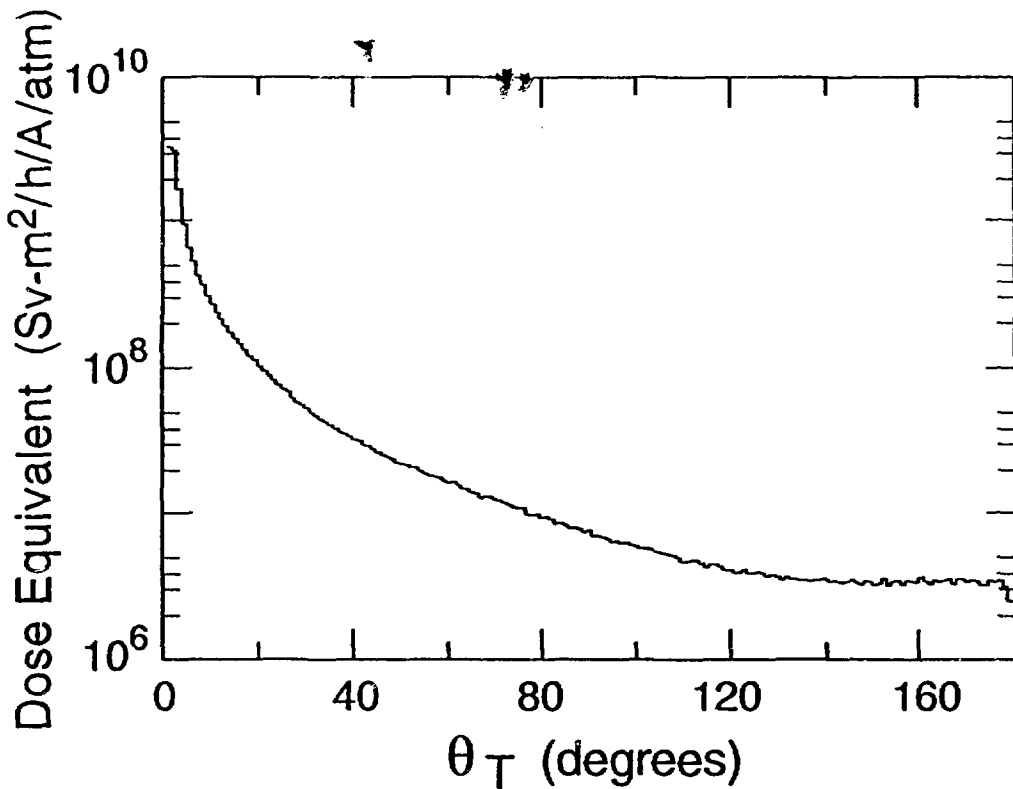

Figure 4. Photon dose equivalent rate one m from a 5-cm-long W target (radius of 2.54 cm) hit by the APS gas bremsstrahlung beam. The storage ring pressure is 1 atm, and the straight section length is 15 m.

$$\theta_{\min} = \tan^{-1}\left(\frac{0.12}{6.9}\right) = 0.996^\circ.$$

Therefore, the minimum angle of concern is 1° .

The photon *DER* for a copper scatterer at this angle is read from Figure 3 to be $8 \times 10^{10} \text{ Sv}\cdot\text{m}^2/\text{hr}\cdot\text{A}\cdot\text{atm}$. This is multiplied by 3.95×10^{-8} to convert the *DER* to the APS conditions of 300 mA and 10^{-9} Torr and to convert to mrem. This gives an adjusted *DER* of $3160 \text{ mrem}\cdot\text{m}^2/\text{hr}$.

The *DER* needs to be adjusted for the distance from the scatterer to the shield point. This distance, s , is

$$s = \frac{DB}{\cos(\theta_H)} = \frac{7.5 \text{ m}}{\cos(1^\circ)} = 7.5 \text{ m}.$$

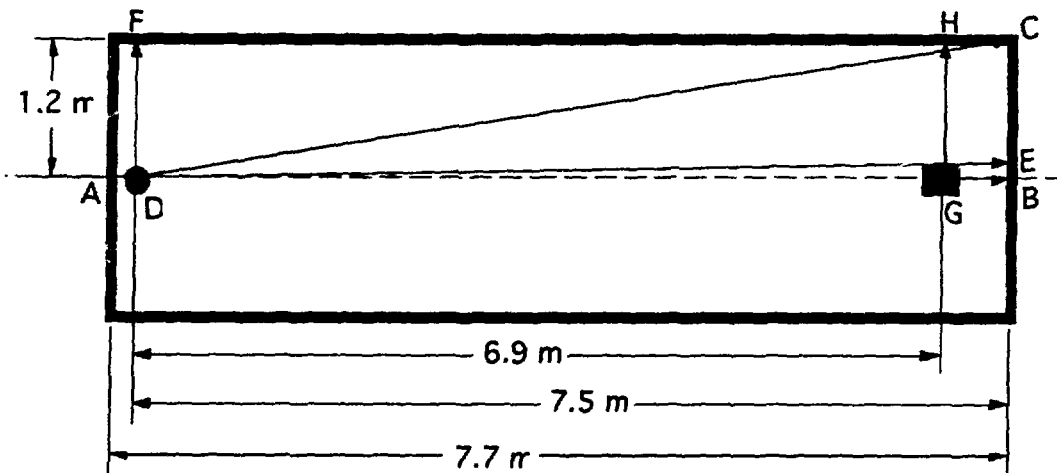

Figure 5. Top view of the FOE used in the sample calculations. Point A is the ratchet wall penetration.

(In this particular case, the angular correction is trivial but is included here for completeness. For greater angles, it is more significant.) The adjustment is made by

$$DER = \frac{DER}{s^2} = \frac{3160 \text{ mrem m}^2 / \text{hr}}{(7.5 \text{ m})^2} = 56.2 \text{ mrem / hr.}$$

This value is the photon *DER* for this case if no shielding is present.

Now the neutron component needs to be considered. The average energy of neutrons produced in secondary gas bremsstrahlung will be a few MeV. Figure 6 shows the neutron yield as a function of primary electron energy for several elements.¹³ The relative yield for a photon beam is similar. The high-Z elements, such as lead and tungsten, used for primary beam shutters and stops pose the most significant neutron problem. The neutron production from monochromator, mirror, and filter materials should be considerably reduced because they are made from lighter elements and are also, typically, thinner targets.

¹³Adapted from W. P. Swanson, "Radiological Safety Aspects of the Operation of Electron Linear Accelerators," IAEA Technical Report Series No. 188, International Atomic Energy Agency, Vienna (1979).

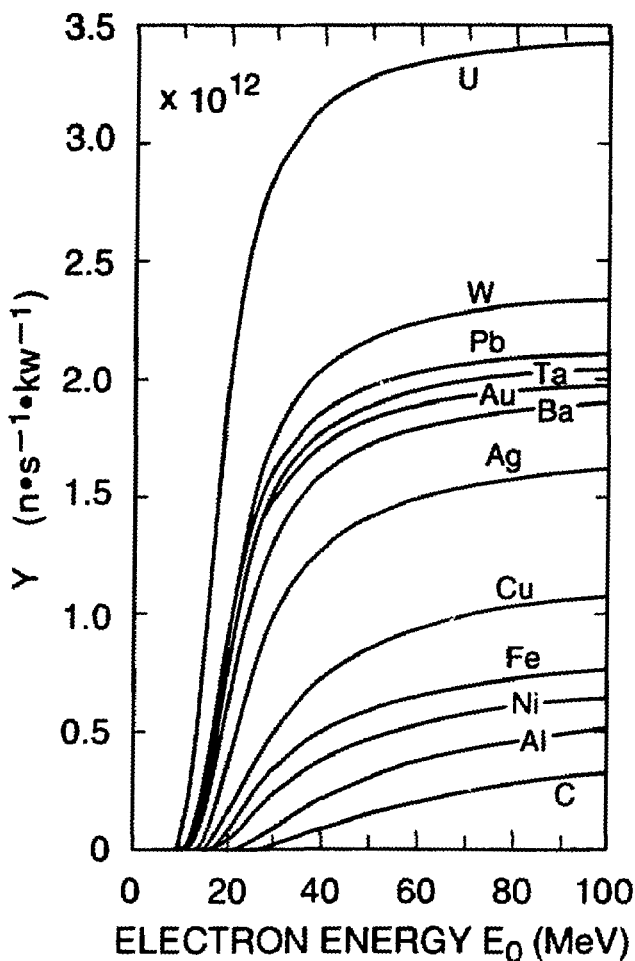

Figure 6. The neutron yield from infinitely thick targets (per kW) as a function of electron beam energy. The calculation disregards target self shielding.¹³

The neutron dose was calculated for a tungsten target (again 30 cm in length and 24 cm transverse to the beam) placed 31.5 m from the center of the straight section (point G). The DER one meter from the target was found to be 0.5 mrem/hr (using a quality factor of 20). The distribution of the neutrons is nearly isotropic and will be assumed to be isotropic for the calculations.

The neutron yield from a copper target of the same size as the tungsten stop will be approximately 40% less leading to a neutron dose equivalent of 0.2 mrem/hr one meter from the scat-

terer. (This is a conservative estimate because the thinner target will give a smaller neutron yield.) Adjusting for the distance from point *D* to *E* (7.5 m) gives a *DER* of 0.0036 mrem/hr. Obviously, for this case, the neutrons do not pose a problem; hence only the photons need be considered. (It will be shown below that neutrons are a factor for shielding for scatter from the tungsten stop.)

Next the needed shielding is determined.

The *DER* after shielding with a thickness of *t* is given by:

$$DER_{\text{shielded}} = DER_{\text{unshielded}} e^{-(\mu/\rho)t}, \text{ and}$$

$$t = \frac{1}{\mu} \ln \left(\frac{DER_{\text{unshielded}}}{DER_{\text{shielded}}} \right).$$

The absorption of photons by lead reaches a minimum around 3 MeV. After several radiation lengths inside the shielding material, the resultant radiation will have a spectrum centered on this minimum. Therefore, the μ/ρ of that energy is the proper value to use. For lead,

$$\left(\frac{\mu}{\rho} \right)_{\text{Pb min}} = \frac{1}{24 \text{ g/cm}^2} = 0.04167 \text{ cm}^2/\text{g}, \text{ and}$$

$$\mu_{\text{Pb min}} = \rho_{\text{Pb}} \left(\frac{\mu}{\rho} \right)_{\text{Pb min}} = \frac{11.35 \text{ g/cm}^3}{24 \text{ g/cm}^2} = 0.473 \text{ cm}^{-1}.$$

The desired dose equivalent rate is 0.25 mrem/hr (in this case, the neutrons are not a factor), so

$$t = \frac{1}{0.473 \text{ cm}^{-1}} \ln \left(\frac{56 \text{ mrem/hr}}{0.25 \text{ mrem/hr}} \right) = 11.44 \text{ cm}.$$

A similar analysis can be made for point *C*, the joint of the back wall to the lateral wall.

The scattering angle to point *C* is found to be

$$\theta_c = \tan^{-1} \left(\frac{BC}{DB} \right) = \tan^{-1} \left(\frac{1.2}{7.5} \right) = 9.09^\circ.$$

From Figure 3, the *DER* is $5 \times 10^8 \text{ Sv}\cdot\text{m}^2/\text{hr}\cdot\text{A}\cdot\text{atm}$. Multiplying by 3.95×10^{-8} gives $19.75 \text{ mrem}\cdot\text{m}^2/\text{hr}$.

Adjusting for distance,

$$s = \frac{DB}{\cos(\theta_c)} = \frac{7.5 \text{ m}}{\cos(9.1^\circ)} = 7.6 \text{ m, and}$$

$$DER = \frac{DER}{s^2} = \frac{19.75 \text{ mrem m}^2 / \text{hr}}{(7.6 \text{ m})^2} = 0.34 \text{ mrem / hr.}$$

Calculating the required lead thickness (as in the case above, neutrons are not a problem)

$$t = \frac{1}{\mu} \ln\left(\frac{DER}{DER_{\text{shielded}}}\right) = \frac{1}{0.473 \text{ cm}^{-1}} \ln\left(\frac{0.34 \text{ mrem / hr}}{0.25 \text{ mrem / hr}}\right) = 0.65 \text{ cm.}$$

The examination of point *F*, the closest position on the lateral wall to the scatterer at point *D*, shows that

1. The scattering angle is 90° . The photon *DER* for that angle is approximately $2.5 \times 10^6 \text{ Sv}\cdot\text{m}^2/\text{hr}\cdot\text{A}\cdot\text{atm}$. This converts to $0.1 \text{ mrem}\cdot\text{m}^2/\text{hr}$ at one m and 0.069 mrem/hr at 1.2 m. Clearly the photon secondary gas bremsstrahlung is not a problem at this high of angle.
2. Following the same logic as above concerning the neutrons, a *DER* of 0.139 mrem/hr is determined. If the *DER* from synchrotron radiation (see below) is less than 0.1 mrem/hr , no additional shielding is needed.

The shielding for the roof can be calculated in a similar way using 2.5 mrem/hr as the design limit. For a roof 1.5 m above the beam (2.9 m total height), secondary gas bremsstrahlung was found not to determine the roof shielding.

3.2.3 Synchrotron Radiation

The synchrotron radiation traveling down the beamline will scatter from every component it strikes. As in the gas bremsstrahlung case, the direct beam is relatively easy to handle with shutters and stops; the scattered radiation is harder to estimate. To determine the necessary shielding for the syn-

chrotron radiation, the PHOTON program was used.^{14,15} PHOTON calculates doses using the following procedure:

1. Calculate the photon flux as a function of energy and vertical opening angle of the synchrotron beam.
2. Attenuate the beam for any filters.
3. Scatter from a chosen target.
4. Convert the resulting photon flux to dose.

Within PHOTON several assumptions are made.

The scattered photons are assumed to come from Compton scattering. With regards to shielding, only relatively high-energy photons (> 50 keV) are of much consequence. For these photons to scatter at significant angles (i.e., to hit the side of a hutch), Compton scattering is by far the dominant process. Bragg scattering from single crystals is not a problem for angles greater than a few degrees.¹⁶

In PHOTON, an isotropic point scatterer is assumed, and the total angle-integrated Compton cross-section is used to calculate the scattered photon spectrum. The isotropic point assumption is reasonable for measurements well away from the source. This is true for most cases in beamline shielding (transport is an exception). Compton scattering is not isotropic; the scattering becomes increasingly forward directed for higher energies. This assumption will tend to overestimate the scattering at large angles and underestimate the scattering in the forward direction.

Additionally, no polarization dependence of the incident beam is recognized. Because the synchrotron beam is normally highly polarized in the horizontal plane, the horizontal scattering will be overestimated, and the vertical scattering underestimated (especially at angles approaching 90°). Because personnel are

¹⁴D. Chapman, N. Gmur, N. Lazarz, and William Thomlinson, NIM A266, 191 (1988).

¹⁵E. Brauer and W. Thomlinson, NIM A266, 195 (1988).

¹⁶D. R. Haeffner in an internal memo to the XFD/RSC. This memo will be expanded and made an APS Light Source Note.

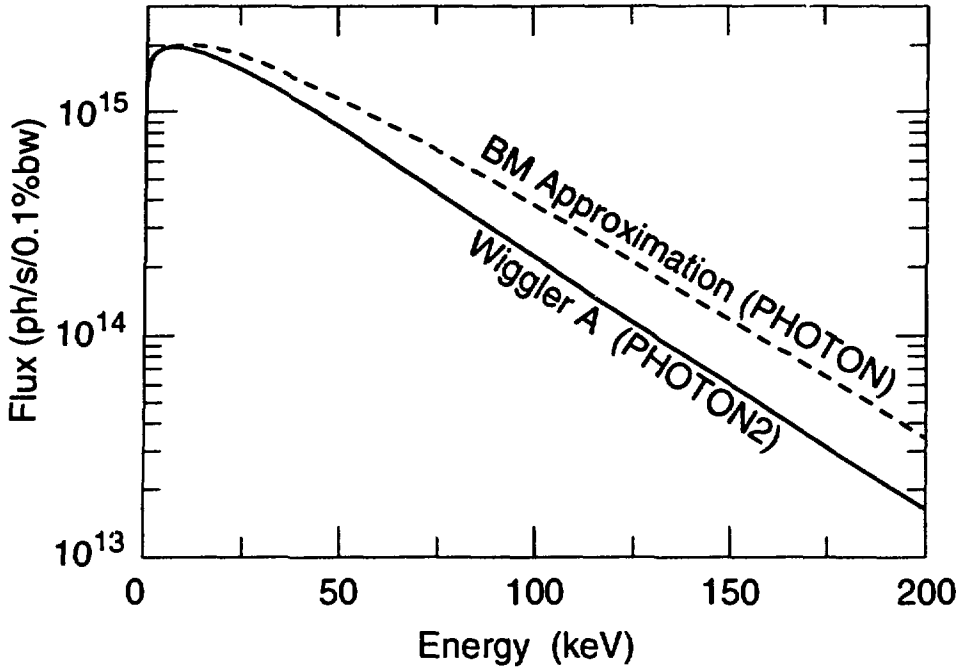

Figure 7. Comparison of PHOTON and PHOTON2 spectrums for the APS Wiggler A.

usually located in the horizontal direction from the scattering source, the omission of polarization dependence is a conservative estimate.

The "narrow beam" attenuation coefficient of the shielding material is used. This will ignore build-up factors of scattered photons. For photons up to several hundred keV shielded by lead, the use of the narrow beam coefficient should have a small effect on the calculation.

Finally, PHOTON calculates the flux for a bending magnet source. This can be used to approximate a wiggler by multiplying the spectrum by the number of poles (twice the number of periods). This overestimates the horizontally off-axis flux. The PHOTON2 program is a modified version of PHOTON that cal-

Table 1. Photon Calculation Parameters

Source	APS Wiggler A	APS Bending Magnet
Positron Energy	7.5 GeV	7.5 GeV
Positron Current	200 mA	200 mA
Critical Energy	37.4 keV	24.0 keV
Number of poles	56	1
Vertical Divergence	$4/\gamma$	$4/\gamma$
Horizontal Divergence	1.08 mrad	6.0 mrad

culates the wiggler spectrum using the proper wiggler horizontal beam distribution.¹⁷ A comparison of the results is shown in Figure 7. (PHOTON2 at the time of these calculations could not do all the shielding estimates that are part of PHOTON. Therefore it was only used for comparison purposes.)

The combination of all these factors indicates that use of PHOTON should overestimate the scattering in the horizontal plane from a wiggler. Experimental results confirm this.¹⁵

Using the parameters shown in Table 1, PHOTON was run for several different targets (air, copper, and lead), with several thicknesses for each. Based on these results, a target of copper 30 cm in length was chosen to be representative. (The difference between targets 3 cm long and 30 cm long is not large.) The PHOTON model hutch has the scatterer 1 m from the walls (lateral, front, and back) and 1.5 m from the roof. Because of the PHOTON assumptions discussed above, the scatter in the forward direction (toward the back wall) may be underestimated. To account for this, the amount of shield-

¹⁷R. J. Dejus, A. M. Khounsary, D. A. Brown, and P. J. Viccaro, NIM A319, 207 (1992).

ing needed to reduce the dose an order of magnitude, one tenth value layer (TVL), was calculated and added to the amount of shielding for the back wall.

PHOTON was used to calculate two scenarios for beamline transport shielding: 1. air scattering due to loss of vacuum, and 2. the scatter from the beam hitting a solid object (including the beampipe).

The vacuum loss calculations were made with the equivalent 30 cm of air at 1 atm as a target. The beampipe was assumed to be 10 cm in diameter. Under normal conditions, negligible scattering will result from residual air in an evacuated beampipe.* However, the vacuum level for beamline transport will not normally be part of the personnel safety system, so the accidental venting of a beamline must be considered. A vacuum loss will be detected after a short time by the resulting diminished flux to the user or (at the longest) by a radiation survey (which will be made on a regular, probably weekly, basis). A limit of 40 hours was used as the maximum amount of time in a year that such a condition could persist. With a limit of 100 mrem for such an accidental situation, the maximum dose equivalent rate should be limited to 2.5 mrem/hr.

For a beamline, if it can be shown that the beam will never strike a solid object, only the vacuum loss shielding is necessary. If this is not the case, scattering from the PHOTON Cu target used for the hutch calculation should be used to determine shielding. In some circumstances, the shielding amount along the transport may vary as a function of distance from the potential scatterer. (Note that, in a white beam transport line, bremsstrahlung radiation must also be considered.)

No calculations were made for beamline transport filled with helium; this is considered a special situation.

* The APS Standard and Modular Components Committee has recommended a beamline transport vacuum of at least 10^{-6} Torr.

4 Shielding Recommendations

For each shielding situation (i.e., ID white beam, bending magnet monochromatic beam, transport, etc.) the synchrotron and gas bremsstrahlung radiation (photons and neutrons) have been calculated for a representative geometry. The requirements for both the gas bremsstrahlung and synchrotron radiation will be given. **The worst case values are the ones that should be used.** In most cases, one source dominates and the contribution of the others becomes negligible, so the calculated shielding for the dominant source is directly found. If the dose equivalent rates through the shielding for two sources are approximately equal, then the sum was kept below the design limit. An appropriate safety factor was added to the final values.

4.1 White Beam Hutches

4.1.1 Insertion Device

To shield the ID white beam hutch and FOEs for **synchrotron radiation only** requires 19 and 16 mm of lead for the back wall and the lateral wall, respectively. The roof will have a very low occupancy rate and will be shielded for 2.5 mrem/hr, which requires 12 mm of lead.

In Section 3.2.2, a lead thickness for **gas bremsstrahlung only** shielding was calculated to be 11.44 cm at the lowest-angle spot on the back wall not shadowed by the tungsten stop. The secondary bremsstrahlung scattering, and hence the required shielding, drops quickly as the angle from the primary beam increases. It is recommended that collimators be placed along the beamline to shadow the back wall from the low-angle scatter of components in the beam. With the use of collimators, the recommended shielding for the entire back wall is 50 mm of lead. A 1 m² portion of the back wall, centered on the direct beam, will require an additional 50 mm of lead. The *DER* from neutrons will be handled by local shielding around the tungsten stops (see below).

A lead thickness of 6.5 mm was calculated for **gas bremsstrahlung only** scatter to the highest dose location (where the back and lateral walls of the

FOE meet). A similar calculation shows that the *DER* to the roof from **gas bremsstrahlung only** is below the design *DER* limit.

To summarize, the bremsstrahlung shielding dominates for the back wall, and the synchrotron radiation dominates for the lateral wall and roof. Lead shielding of 50 mm is needed for the entire back wall, with an additional 50 mm (100 mm total) for the center portion of the back wall. Lead shielding of 19 mm is needed for the lateral wall, and 12 mm is needed for the roof.

4.1.2 Bending Magnet

The bending magnet white beam hutches and FOEs require 9, 8, and 6 mm of lead for the back wall, lateral wall, and roof, respectively, for **synchrotron radiation only**.

The gas bremsstrahlung for a bending magnet when compared to that for an ID is reduced by the effective straight section the beamline sees. The length of the positron path in the bending magnet is 6 milliradians \times 39 m (the maximum horizontal divergence and radius of the bending magnet) or 0.234 m. The ratio of ID to bending magnet gas bremsstrahlung is $15/0.234 = 64$. The shielding thickness scales as the natural log of this number, 4.2. Dividing the recommended ID shielding thicknesses by this value leads to shielding of 12 mm for the back wall, 6 mm for the lateral wall, and 3 mm for the roof for **bremsstrahlung only**. An area of 1 m² around the direct beam will require an additional 12 mm (a total of 24 mm) of lead shielding. As with the ID FOE, collimators should be used to reduce the line of sight to the back wall.

Taking the larger of these values gives lead thicknesses of 12 mm for the back wall (24 locally), 8 mm for the lateral wall, and 6 mm for the roof.

4.2 Monochromatic Beam Hutches

For the monochromatic hutch shielding calculations, a conservative band-pass value of 0.1% was assumed for the monochromator. Most of the radiation that needs to be shielded results from the higher harmonics of the transmitted beam. It is assumed that the bremsstrahlung radiation has been stopped upstream.

4.2.1 Insertion Device

The ID source requires lead shielding of 12.5 mm for the back (downstream) wall, 10 mm for the front (upstream) and lateral walls, and 6 mm for the roof.

4.2.2 Bending Magnet

The bending magnet source requires lead shielding of 7 mm for the back wall, 6 mm for the front and lateral walls, and 4 mm for the roof.

4.3 Transport

4.3.1 White Beam

It is recommended that, wherever possible, white beam transport be avoided. If deemed necessary, a careful ray trace should be carried out, and collimation used to limit the amount of transport that can be hit by the bremsstrahlung beam. Some parameters for bremsstrahlung ray tracing are given in Appendix D. Wherever possible, slits, shutters, and any other components that might be struck by the beam should be placed inside an experimental hutch.

To shield the ID beamlines against **synchrotron radiation only**, 11 mm of lead is needed for air scattering. For a solid scatterer, 21 mm of lead will be needed for the **synchrotron radiation only**. Additionally, for the solid scattering, an analysis of secondary bremsstrahlung scattering must be made (by the user) using the basic methods given above.

For the bending magnet, 6 mm of lead is needed for air and 11 mm for solid scatterers for **synchrotron radiation only**. A calculation should be made (by the user) to determine if the secondary bremsstrahlung scattering is a problem for the solid scatterer.

4.3.2 Monochromatic Beam

For the ID with a 0.1% band-pass monochromator, the required lead shielding on transport is 8 mm for vacuum loss scattering. Shielding of 15 mm of lead is recommended for areas in which there are potential solid scatterers.

Likewise, for the bending magnet, the recommended lead shielding for vacuum loss is 5 mm and 7 mm for potential solid scatterers.

4.4 Shutters/Stops

All APS photon shutters (for white and monochromatic beams) are designed to be redundant; two shielding blocks will stop the beam when the shutter is closed. Also, the personnel safety interlock system will detect any shutter failure through redundant switches and will take appropriate measures to shut off the beam during a fault condition. Stops are not movable; hence they are not redundant.

A previous APS report⁶ recommended that shutters for the APS beamlines be lead blocks 25 cm along and 20 cm transverse to the beam. For the APS front end shutters, the size of the blocks was increased to 30 cm by 24 cm for a comfortable safety factor and changed from lead to tungsten for engineering considerations.¹ Thus, a 30 cm by 24 cm tungsten block is recommended for direct gas bremsstrahlung stops.

As discussed above, a tungsten stop will be a source of neutron generation. For a stop placed at point G in Figure 5 (1.2 m from the lateral wall and 0.6 m from the back wall), a neutron *DER* of 0.34 mrem/hr will exist at the lateral wall, and a *DER* of 1.38 mrem/hr will exist at the back wall. Local shielding should be used around the stop to reduce these values to acceptable levels.

If polyethylene is used for neutron shielding, 13 cm is needed to reduce 2.0 MeV neutrons by an order of magnitude.¹⁸ Hence, for the lateral wall, 1.73 cm is needed to reduce the neutron *DER* to 0.25 mrem/hr, and 6 cm is needed to reduce the neutron *DER* to 0.12 mrem/hr. For the back wall, 6 cm is needed for a neutron *DER* of 0.25 mrem/hr, and 14 cm is needed for a neutron *DER* of 0.12 mrem/hr. It should be remembered that the total photon and neutron design *DER* must add to 0.25 mrem/hr. It is recommended that lead or tungsten stops be designed so that the local shielding reduces the neutron

¹⁸"Neutron Contamination from Medical Electron Accelerators," NCRP Report No. 79, National Council on Radiation Protection and Measurements, Bethesda, Maryland (1984).

DER to at least 0.12 mrem/hr. The neutron *DER* around the stop should be checked during beamline commissioning.

The thickness of each monochromatic beam shutter block was calculated with PHOTON so that no more than 2.5 mrem/hr would be present if only one block of the shutter closes. In normal redundant operation, this rate would be much lower. The tungsten thickness of each shutter is specified to be 6.5 cm for ID sources and 2.1 cm for bending magnet sources. The stops should be 7.7 and 2.7 cm of tungsten for ID and bending magnet sources, respectively.

Appendix A: Definition of Basic Radiological Quantities

A.1 Absorbed Dose

The absorbed dose (D) is defined as

$$D = \frac{d\varepsilon}{dm},$$

where $d\varepsilon$ is the mean energy imparted by ionizing radiation and dm , is mass of the volume element. The unit for absorbed dose is the rad, where

$$1 \text{ rad} = 100 \text{ erg / g}.$$

The SI unit for absorbed dose is the gray (Gy), where

$$1 \text{ Gy} = 1 \text{ J / kg} = 100 \text{ rad}.$$

A.2 Dose Equivalent

The dose equivalent (H) is defined as

$$H = DQN,$$

where Q is the quality factor, and N is other modifying factors. Q accounts for the biological effectiveness of different types of radiation. It has a value of 1 for photons (x-rays and γ -rays), and 20 for fast neutrons (200 keV to 1 MeV). The unit for dose equivalent is the rem. For photons, 1 rad and 1 rem are equivalent; for neutrons 1 rad is equivalent to 20 rem.¹⁹

The SI unit for dose equivalent is the sievert (Sv)

$$1 \text{ Sv} = 100 \text{ rem}.$$

A.3 Effective Dose Equivalent

The effective dose equivalent (H_E) (measured in rem) accounts for nonuniform irradiation of the whole body and is defined as

¹⁹Radiological Control Manual, Section 128, paragraph 1, page 1-16.

$$H_E = \sum_T w_T H_T,$$

where w_T is the proportion of stochastic risk for the tissue T (compared to the total risk), and H_T is the dose equivalent to the tissue T . For example:

$$w_{\text{gonads}} = 0.25, \text{ and}$$

$$w_{\text{breast}} = 0.15.$$

The SI unit for effective dose equivalent is the sievert (Sv).

Appendix B: APS Undulator Shielding

The radiation from synchrotron radiation and the resultant shielding for beamlines having only undulators was calculated using PHOTON. As discussed above, PHOTON calculates the initial beam using a bending magnet source. Figure B-1 compares the PHOTON approximation with a properly calculated undulator spectrum. Table B-1 gives the PHOTON calculation parameters.

For the white beam hutch, the **synchrotron radiation only** would require lead shielding of 12.5, 10, and 7 mm for the back and lateral walls and the roof, respectively. The gas bremsstrahlung values would be the same as those for Wiggler A and would dominate the shielding requirements.

For a monochromatic hutch, the **synchrotron radiation only** requires lead of 8, 6, and 5 mm for the back and lateral walls and the roof, respectively. As in the wiggler case, the calculation was made with a 0.1% band-pass value. The results are to be compared with the 12.5, 10, and 6 mm values for Wiggler A.

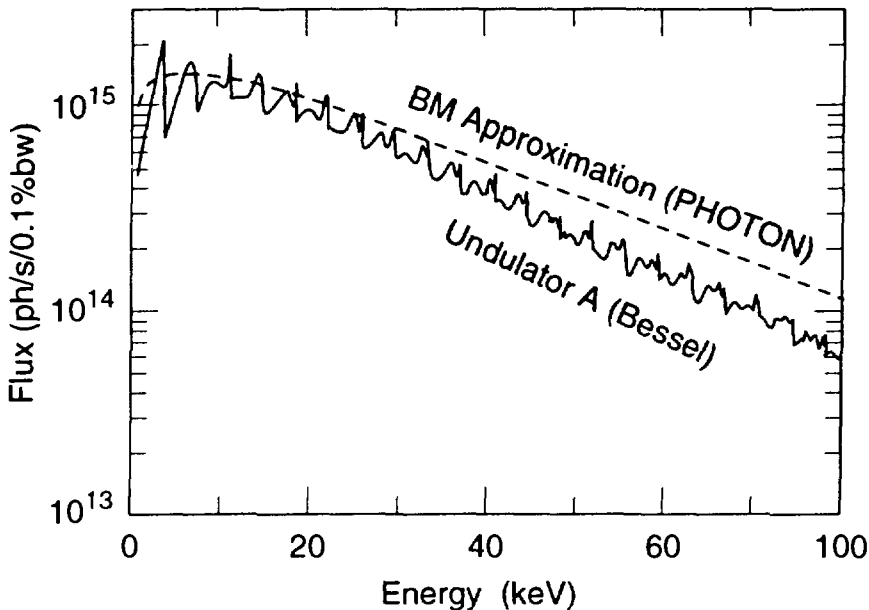

Figure B-1. The PHOTON bending magnet approximation compared to an undulator calculation.

Table B-1 Photon Calculation Parameters: Undulator Case

Source	APS Undulator A
Positron Energy	7.5 GeV
Positron Current	200 mA
Critical Energy	27.1 keV
Number of poles	144
Vertical Divergence	$4/\gamma$
Horizontal Divergence	0.3 mrad

Appendix C: Radiation Environment of High-Energy Storage Rings

The following description of the interaction of electrons (or positrons) with matter, and the consequential production of photons, neutrons, and muons is given in order that the radiation environment of a high-energy storage ring be better understood.

C.1 Electrons and Photons

When high-energy electrons interact with matter, only a small fraction of the energy is dissipated as a result of collision processes. A large fraction is spent in the production of high-energy photons (bremsstrahlung). These photons produce further electrons through pair production or Compton collisions. These new electrons radiate more photons, which in turn interact to produce more electrons.

At each new step, the number of particles increases, and the average energy decreases. This process continues until the electrons fall into the energy range where radiation losses no longer compete with collision losses. Eventually, the energy of the primary electron is completely dissipated in excitation and ionization of the atoms resulting in heat production. This entire process results in a cascade of photons, electrons, and positrons called an electromagnetic shower (or electromagnetic cascade). Figure C-1 illustrates the various processes that take place within an electromagnetic shower.

A shower is produced when the primary beam energy is much greater than the critical energy. The critical energy, E_c , is the electron energy at which the average energy loss due to radiation equals that due to ionization and is given by

$$E_c (\text{MeV}) = \frac{800}{(Z + 1.2)},$$

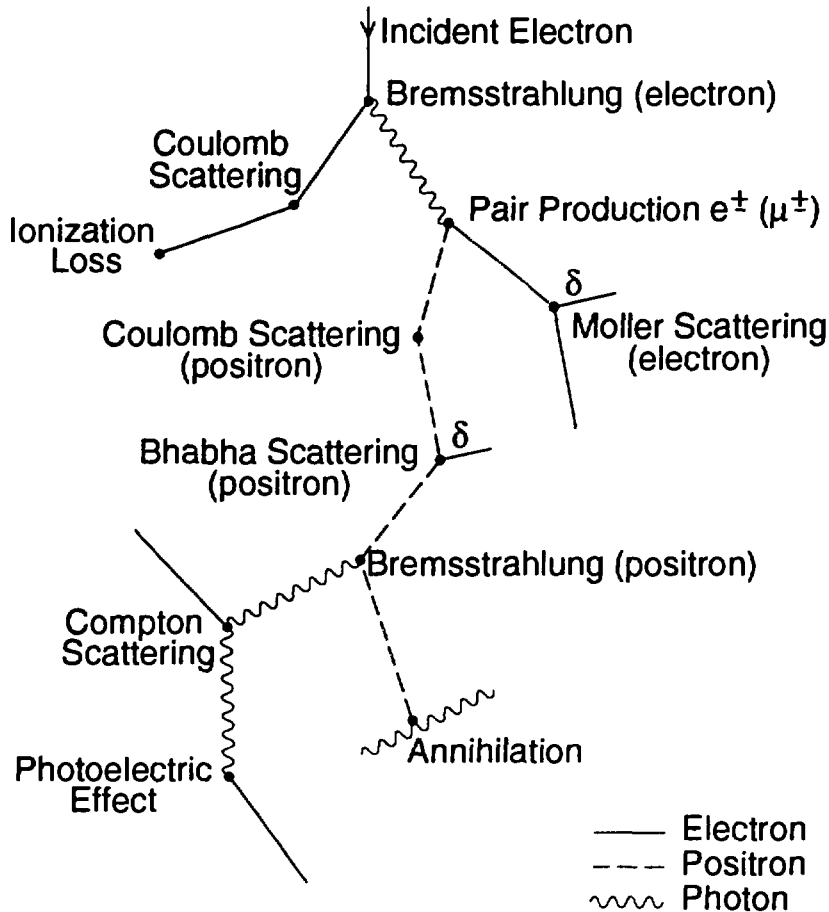

Figure C-1. A schematic of an electromagnetic shower caused by an electron hitting a target.

where Z is the atomic number of the target material.²⁰ The electromagnetic shower contains photons of all energies up to the primary particle energy. The photon spectrum has a $1/E^2$ distribution for thick targets, and a $1/E$ distribution for thin targets (here, E is the photon energy).²¹

The distance needed to reduce, by radiation, the average electron's energy to $1/e$ of its original value is called a radiation length, X_0 . In the high-energy limit²⁰

²⁰W. P. Swanson and R. H. Thomas, "Dosimetry for Radiological Protection at High-Energy Particle Accelerators," in *The Dosimetry of Ionizing Radiation*, Vol. III, (New York: Academic Press, 1990).

²¹A. Fasso, K. Goebel, M. Hofert, T. Ranft, and G. Stevenson, *Shielding Against High-Energy Radiation*, (New York: Springer-Verlag, 1990).

$$X_0(\text{g/cm}^2) = 716A \frac{Z(Z+1)}{\ln\left(\frac{183}{\sqrt{Z}}\right)},$$

where A is the atomic number.

The characteristic angle of photons and electrons emitted by bremsstrahlung and pair production is given by

$$\theta_c = \frac{m_e}{E_0},$$

where θ_c is in radians, m_e and E_0 are the rest mass and energy of the electron. This angle is typically very small, meaning that the shower is strongly peaked in the forward direction.

Multiple Coulomb and Compton scattering both depend on Z and are important for materials of high atomic number. Cascades developing in high- Z materials contain a large proportion of particles traveling at large angles from the shower axis and even scattered backward. The mean scattering angle (in radians) for an electron of energy E_0 having traveled a distance x in the target is given by²¹

$$\theta \approx 21.2 \sqrt{\frac{1}{E_0} \frac{x}{X_0}}.$$

There is also a transverse development of the shower due to Coulomb scattering of the electrons and Compton scattering of the photons. This is described by the Moliere length, X_m .²⁰

$$X_m = X_0 \frac{21.2}{E_c(\text{MeV})}.$$

The electron shower reaches a maximum when the average electron energy approaches E_c . At this depth, the electron energy is too low to propagate the shower and continued propagation occurs through photons. This depth in radiation lengths is given by²¹

$$t_{\max} = 1.01 \left[\ln \left(\frac{T_0}{E_c} \right) - 1 \right] ,$$

where T_0 is the kinetic energy of the electron.

The photon energy at which the minimum attenuation coefficient, μ_{\min} , occurs is called the Compton minimum and is typically 1/2 to 1/3 E_c for all materials. The photon energy for μ_{\min} occurs when the energy for the cross-sections for Compton scattering and pair production are nearly equal. At this energy Compton scattered electrons and photons have energies well below E_c and cannot effectively replenish the shower. Therefore, μ_{\min} can be used as the attenuation coefficient for the entire shower. The minimum attenuation length, λ_{\min} , is given by $1/\mu_{\min}$. Measured attenuation lengths in the GeV range are close to λ_{\min} , with the best agreement for low- Z materials. Table C-1 lists some radiological parameters for different materials.

C.2 Neutrons

A small fraction (0.2%) of the bremsstrahlung energy in the shower goes into the production of hadrons including neutrons, protons, and pions. Figure C-2 shows the photon cross sections in copper (in barns/atom). There are three neutron production mechanisms: giant resonance neutrons (GRN) below 30 MeV, neutrons between 30 and 150 MeV from the quasi-deuteron process, and neutrons released as a product of pion production at photon energies above 150 MeV.

Table C-1 Radiological Parameters for Different Materials

Material	E_c (MeV)	t_{max}	x_0 (cm)	λ_{min} (g/cm²)	x_m (cm)	(γ,n) Threshold (MeV)
Air	10.2	3.3	30380.	62.5	31400.	10.55 (¹⁴ N) 15.66 (¹⁶ O)
Copper	24.8	4.7	1.44	32.8	1.23	10.85 (⁶³ Cu) 9.91 (⁶⁵ Cu)
Lead	10.2	5.6	0.56	23.9	1.25	8.09 (²⁰⁶ Pb) 7.37 (²⁰⁸ Pb)
Tungsten	9.51	5.6	0.35	24.8	0.73	8.41 (¹⁸⁰ W)

Neutrons will be produced in any material struck by the electron or bremsstrahlung beam above threshold energies that vary from 10-19 MeV for light nuclei and 4-6 MeV for heavy nuclei.¹³ (Exceptions are ²H and ⁹Be, which have threshold energies of 2.2 and 1.67 MeV, respectively.)

Giant resonant neutrons occur when an absorbed photon introduces resonance into the nucleus. At low photon energies, the GRN dominate because of the larger number of photons and the relatively large cross sections. The giant resonance cross-section reaches a maximum at photon energies of about 20-23 MeV for light nuclei (<40) and 13-18 MeV for heavier nuclei. The GRN are of low energy, with an average of a few MeV. In general, they can be considered to be produced isotropically.

At energies between 30 and 300 MeV, the photon interacts with a neutron-proton pair instead of with the nucleus as a whole.¹³ This mechanism is called the "pseudo-deuteron" or "quasi-deuteron" effect.

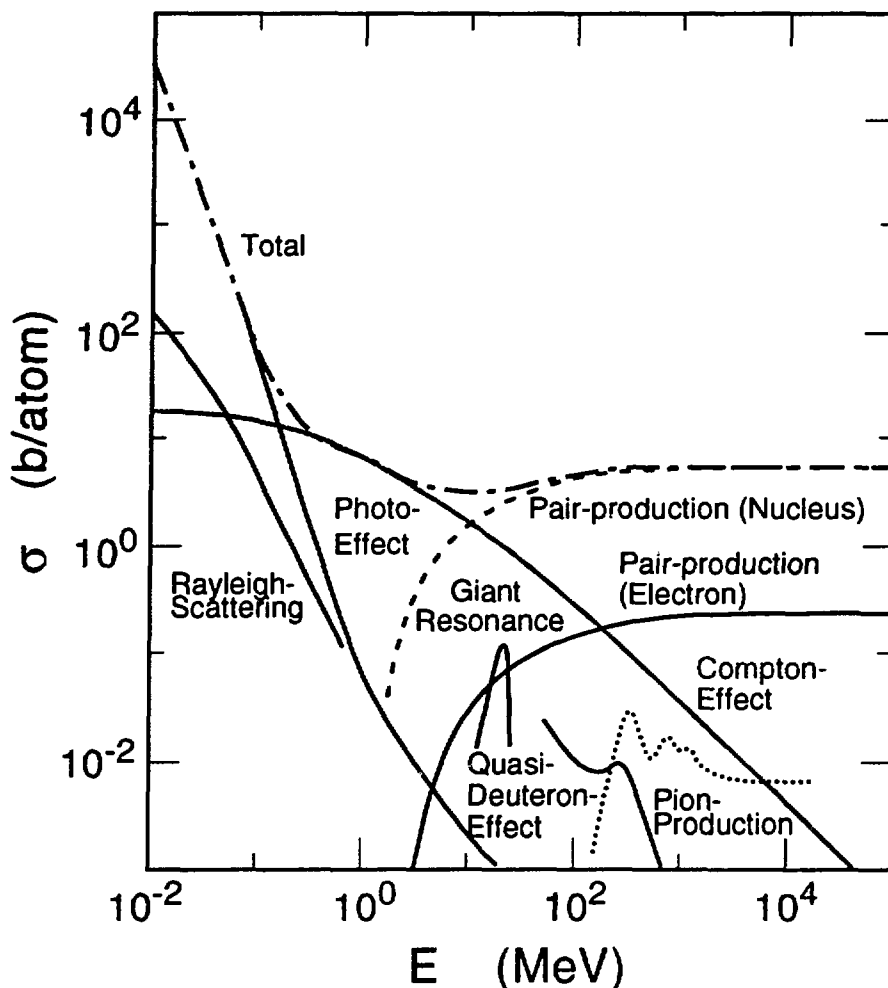

Figure C-2. Photon cross section for Cu.²²

Above photon energies of 140 MeV, the cross section rises again due to photo-pion production and goes through a number of resonance peaks. These peaks are only a fraction of the giant resonance cross sections. However, the neutrons released as a product of photo-pion reactions are much higher in energy and, therefore, much more penetrating than GRN. These neutrons are peaked in the forward direction. For shield thicknesses greater than 2 m of

²²Adapted from E. Freytag, *Strahlenschutz an Hochenergiebeschleunigern*, (Karlsruhe: G. Braun, 1972).

concrete, these neutrons dominate and continually regenerate a field of lower energy neutrons and neutron-capture gamma rays. Thus, the dose equivalent outside the shield will have both neutron and photon components.

C.3 Muons

Muon pair production (μ^+ , μ^-) by photons becomes possible at energies greater than about 211 MeV (2×105.66 MeV). This process is similar to the electron-positron pair production, except that the cross sections scale by the ratio of the square of the particle masses, $(m_e/m_\mu)^2 = 1/40,000$. Thus the cross section for muon pair production is orders of magnitude smaller than that for electron-positron pair production. The dominant process is the coherent production, in which the nucleus remains intact as it recoils from the interaction of the photons with the target nucleus.

Muons are also produced during the decay of Π^\pm and K^\pm mesons (photo produced), but, depending on the decay path, these fluences are much smaller than those from direct muon pair production.²⁰ The muon fluence is very highly peaked in the forward direction. The typical beam diameters outside thick shielding are about 10-20 cm.

Because of their large masses, muons do not readily radiate energy by bremsstrahlung except at very high energies (>50 GeV). Muons with energies below about 50 GeV mainly lose their energy by ionization and hence have a fairly well-defined range associated with each energy.

For most accelerator facilities that are well shielded, muons do not pose a problem until the beam energy exceeds 1 GeV. Because the muons are very highly peaked in the forward direction, they are shielded in the forward direction with a beam stop. They are rarely a problem for transverse shielding.

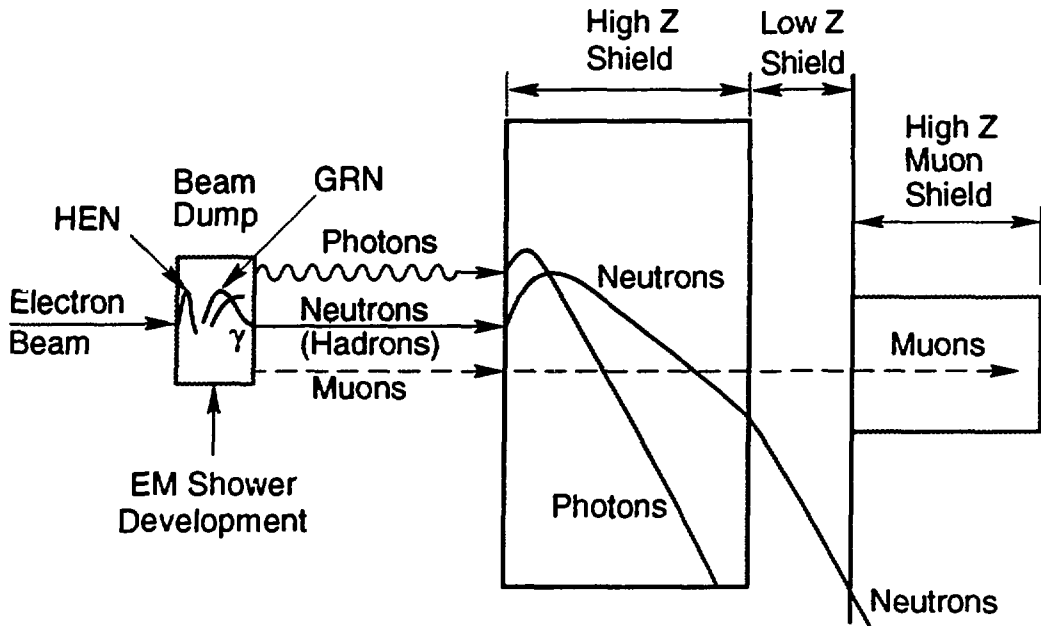

Figure C-3. Typical high-energy electron accelerator shield.

C.4 Typical High-Energy Accelerator Shield

Figure C-3 shows a typical high-energy electron accelerator shield. Typical high- Z shield materials are lead and tungsten. Typical low- Z materials are hydrogenous (e.g., concrete and polyethylene). High- Z materials do not provide any significant attenuation for neutrons, but can degrade the neutron energy through inelastic scattering, thus making the hydrogenous neutron-shielding material more effective.

Concrete has a λ_{min} of 42 g/cm^2 for photons, and an attenuation length of 30 g/cm^2 for GRN. Concrete shielding of 30 cm reduces the photon dose rate by a factor of 5 and the neutron dose by a factor of 10. Hence, shielding walls of a storage ring are normally made of concrete.

Appendix D: Front End Collimation of Bremsstrahlung Beams

Figures D1-D4 show the ray-tracing diagrams of the collimation in the APS front ends. These drawings define the largest possible angular excursions a primary and secondary bremsstrahlung beam may have coming out of the ratchet wall penetration. Detailed description of APS front end components can be found in other APS documents.²³

²³D. Shu and T. Kuzay, *General Design of the Layout for the Advanced Photon Source Beamline Front Ends*, ANL/APS/LS-228 (1993).

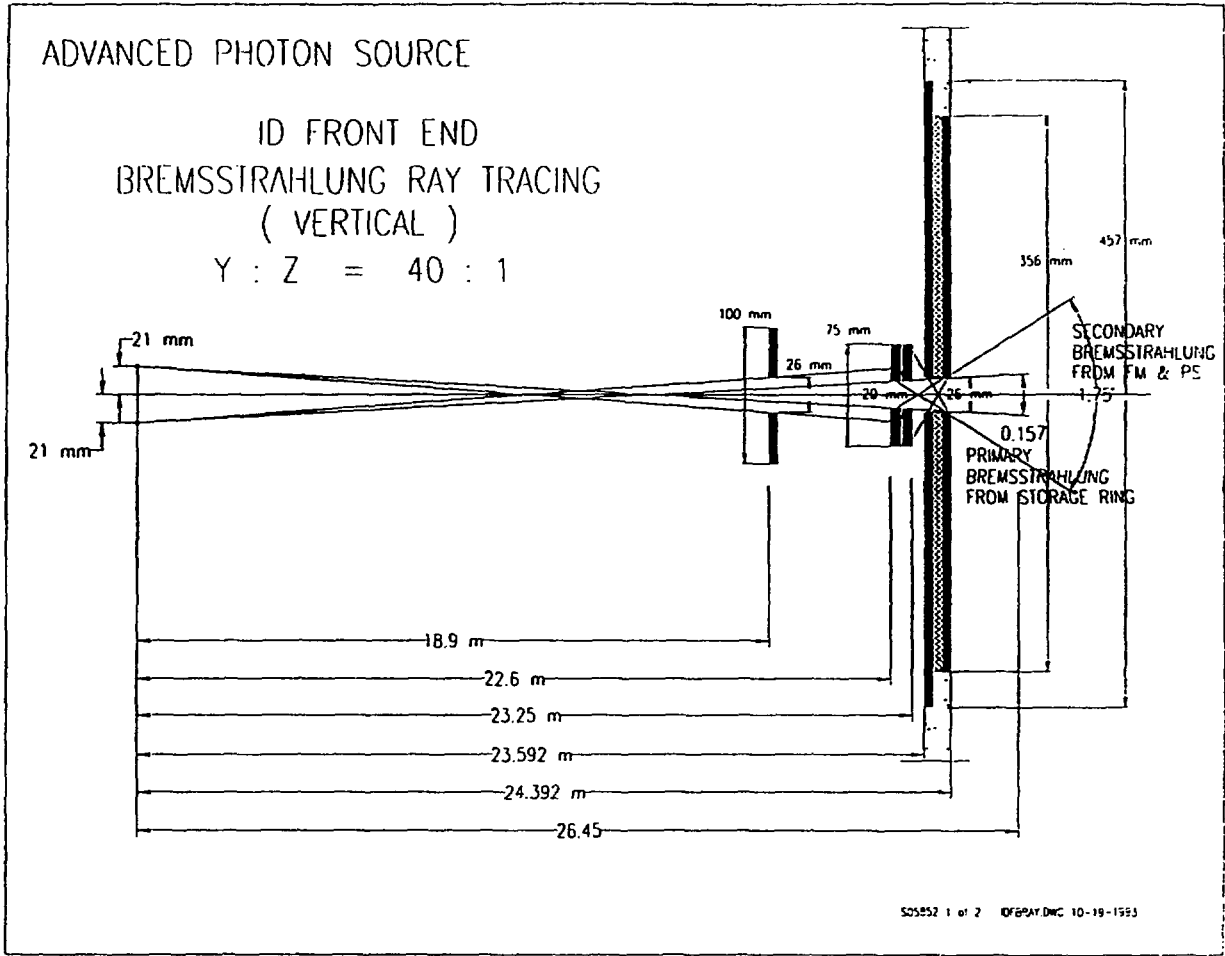
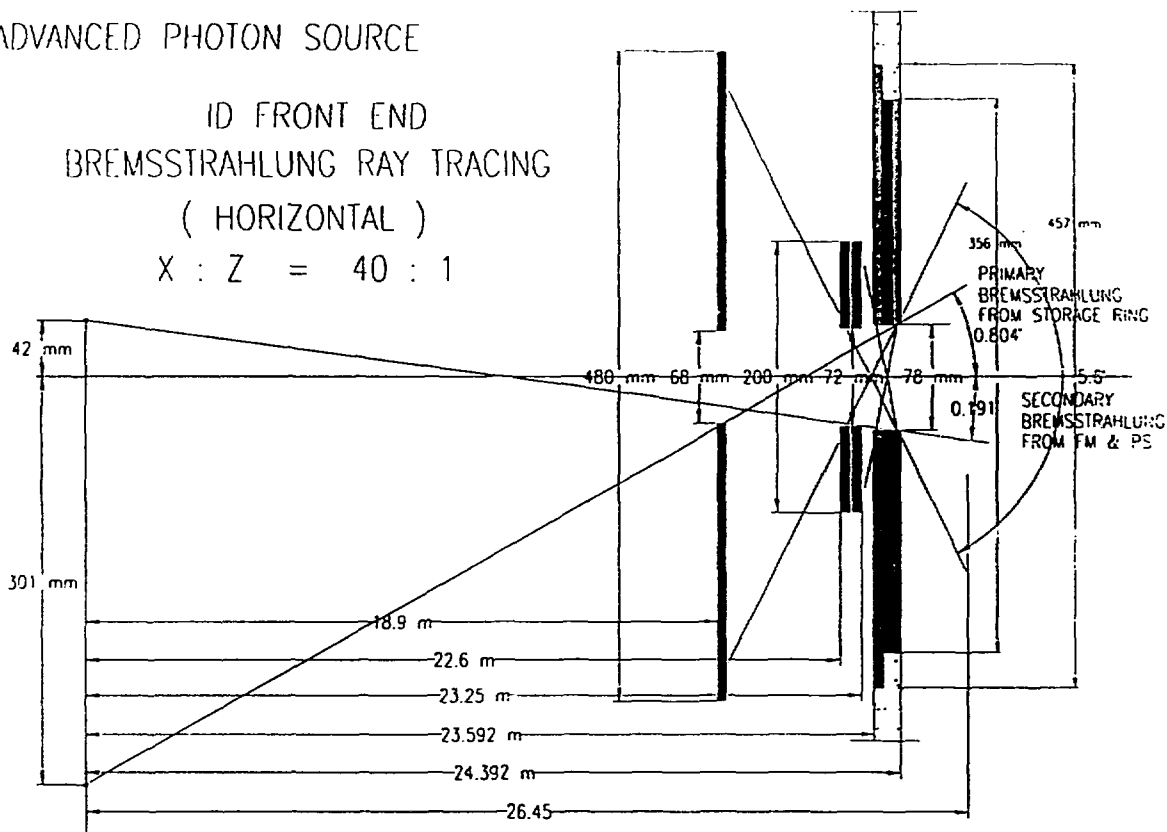

Figure D-1. The bremsstrahlung vertical ray tracing for the APS insertion device front end.

ADVANCED PHOTON SOURCE

ID FRONT END
BREMSSTRAHLUNG RAY TRACING
(HORIZONTAL)

X : Z = 40 : 1



S05652 2 of 2 07BRAY.DWG 10-19-1993

Figure D-2. The bremsstrahlung horizontal ray tracing for the APS insertion device front end.

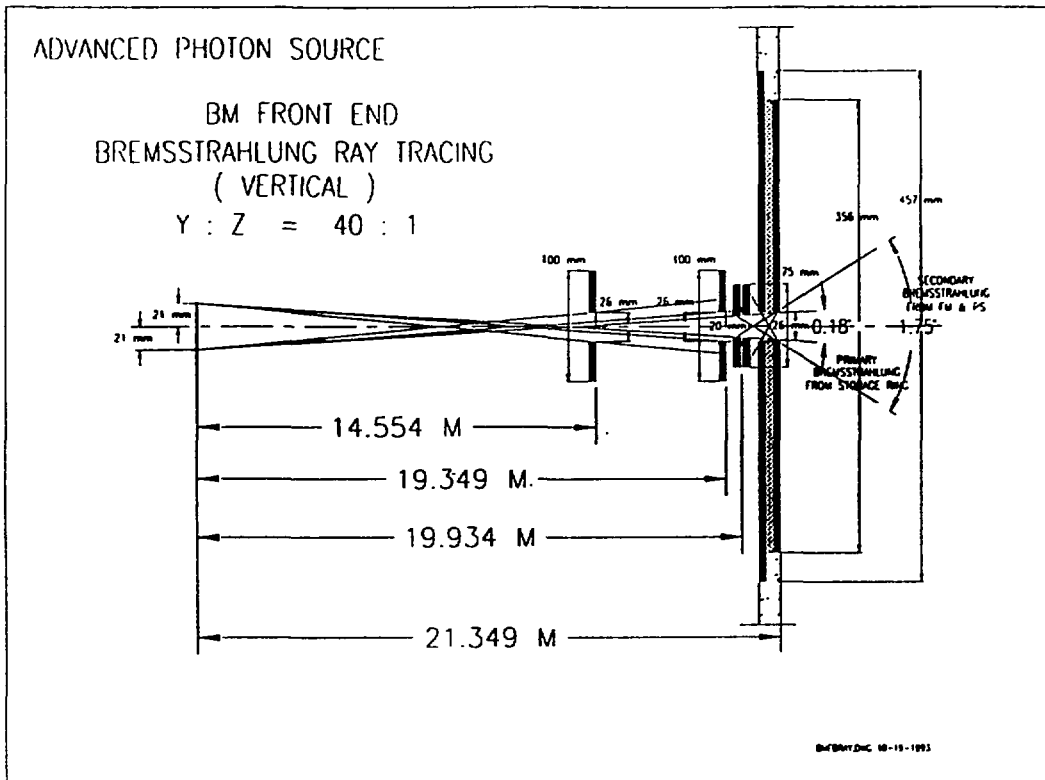

Figure D-3. The bremsstrahlung vertical ray tracing for the APS bending magnet front end.

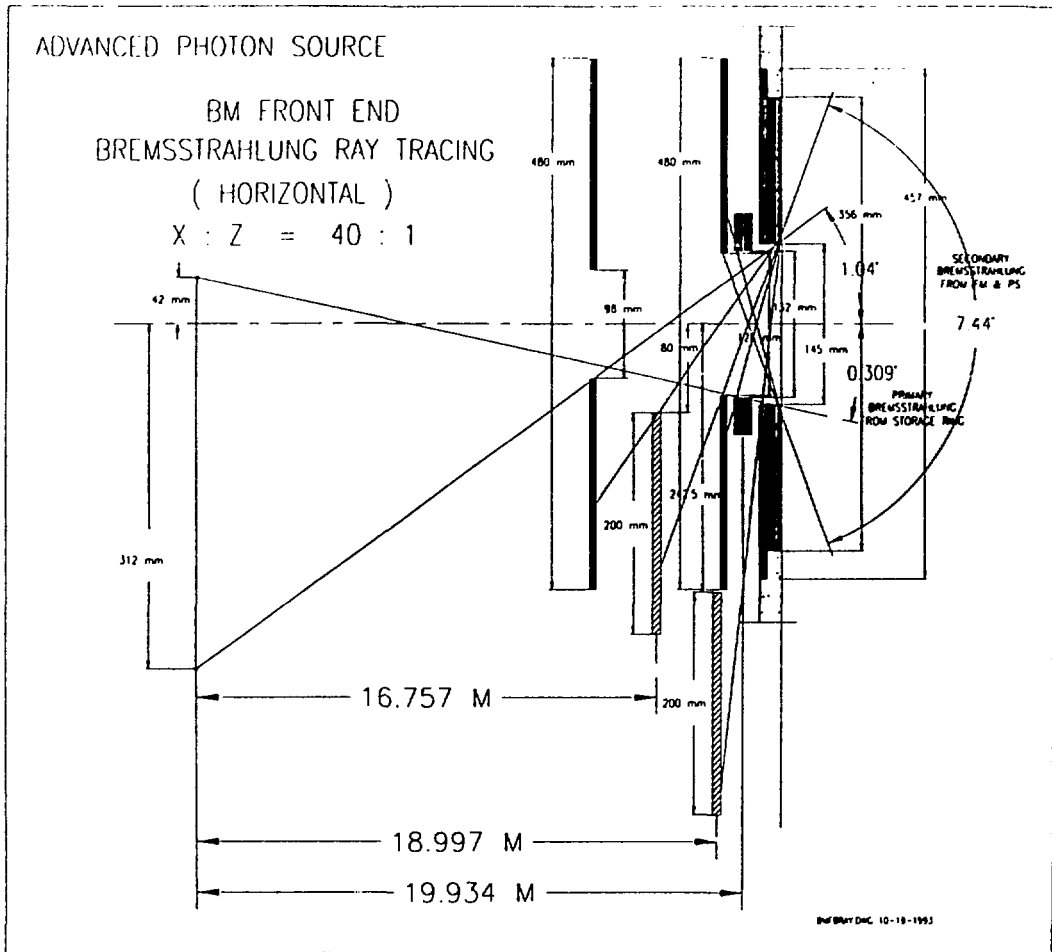

Figure D-4. The bremsstrahlung horizontal ray tracing for the APS bending magnet front end.