

WATCH ALPHABETIC SYMBOLS!!!!

CONVENTIONAL RF SYSTEM DESIGN

M. Puglisi
Sincrotrone Trieste, Italy

Abstract

The design of a conventional RF system is always complex and must fit the needs of the particular machine for which it is planned. It follows that many different design criteria should be considered and analyzed, thus exceeding the narrow limits of a lecture. For this reason only the fundamental components of an RF system, including the generators, are considered in this short seminar. The most common formulas are simply presented in the text, while their derivations are shown in the appendices to facilitate, if desired, a more advanced level of understanding.

1. INTRODUCTION

In dynamic machines the charged particles exchange energy with the electric field (*positive or negative acceleration*). The acceleration can be:

- a) along a straight path - linear accelerators, (*single-pass acceleration*);
- b) along a closed orbit - cyclic accelerators, (*many-pass acceleration*).

In both cases, because the curl of the electric field cannot be zero, it follows that a static field cannot be used. In fact we know that: $\text{curl } E = -\frac{dB}{dt}$.

In principle any non-constant E.M. field could be used, but due to the huge amount of technology derived from radio communications, sinusoidal radio-frequency fields are used. The equipments, which create and apply the field to the charged particles, are known as the *RF-systems* or, more simply, the *RF*.

2. THE ACCELERATING GAP

Basically RF acceleration is obtained by creating a suitable RF field inside one or more gaps of the vacuum chamber which is supposed to be metallic. These accelerating gaps can be obtained using two conceptually different devices:

- drift tubes;
- cavity resonators.

First of all we study the behaviour of a gap (no matter how it is made). We make the hypothesis that the field E_z is uniform along the axis of the gap and depends sinusoidally upon the time:

$$E_z = E_0 \cos(\omega t + j).$$

Phase j is referred to the particle which for $t = 0$ is in the middle of the gap ($z = 0$). The voltage gain is then:

$$V = E_0 \int_{-G/2}^{+G/2} \cos(\omega t + \varphi) dz. \quad (1)$$

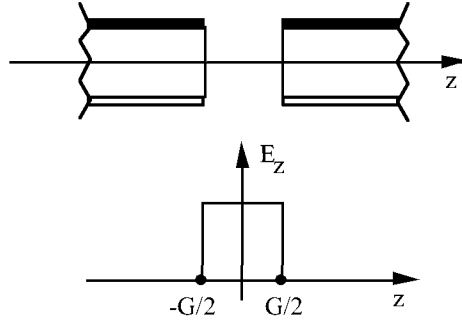

Fig. 1 RF gap

Normally the energy imparted in a single pass is small compared with the kinetic energy of the particle. In this case we assume that the speed of the particle does not change during the transit. Consequently $z = \beta ct$ and Eq. (1) becomes:

$$V = E_0 \int_{-G/2}^{+G/2} \cos \left(\frac{\omega z}{\beta c} + \varphi \right) dz = 2E_0 \cos \varphi \frac{\sin \frac{\omega G}{2\beta c}}{\frac{\omega}{\beta c}}.$$

Rearranging we write:

$$V = E_0 G \cos \varphi \frac{\sin \frac{\omega G}{2\beta c}}{\frac{\omega G}{2\beta c}} = E_0 G \tau \cos \varphi. \quad (2)$$

where t is the well-known transit-time or gap factor.

If we define the transit angle $q = \frac{\omega G}{\beta c} = \frac{2\pi G}{\beta c T} = 2\pi \frac{G}{\lambda_p}$, where l_p is the distance covered by the particle during one period T of the RF field, then the transit-time factor becomes:

$$\tau = \frac{\sin \theta / 2}{\theta / 2}. \quad (3)$$

3. THE DRIFT TUBE

Schematically we can imagine that a portion of the vacuum chamber is replaced by a shorter tube which is connected with the RF voltage (Fig. 2). If the free-space wavelength of the electric field is much larger than the physical length $L-G$, then we can assume that the whole drift tube has the same voltage. Consequently if the electric field in gap (1) is:

$$E_1 = \frac{V}{G} \cos (\omega t + \varphi)$$

then in gap (2) we have:

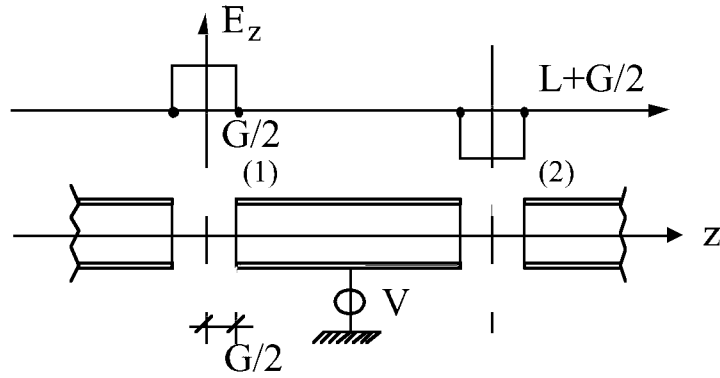

Fig. 2 The physical length of the drift tube is $L-G$, while G is the length of each gap

$$E_2 = -\frac{V}{G} \cos(\omega t + \varphi) .$$

It is then evident that the energy gained by the particle passing through gap (1) will be doubled if and only if:

$$\frac{\omega L}{\beta c} = \pi . \quad (4)$$

Nevertheless to find the effect of the drift tube, we proceed as in the previous case and evaluate the integral:

$$V = E_0 \left\{ \int_{-G/2}^{+G/2} \cos(\omega t + \varphi) dz - \int_{L-G/2}^{L+G/2} \cos(\omega t + \varphi) dz \right\} . \quad (5)$$

Using the same substitution as above, $z = bct$, and integrating, we obtain the general formula:

$$V = E_0 G \frac{\sin \theta / 2}{\theta / 2} \left[\cos \varphi - \cos \left(\varphi + \frac{\omega L}{\beta c} \right) \right] . \quad (6)$$

It is then confirmed that if $\frac{\omega L}{\beta c} = \pi$, then:

$$V = 2E_0 G \tau \cos \varphi .$$

If $l_p = bcT$ is the distance covered by the particle during one RF period, then the synchronism condition (4) becomes:

$$L = \frac{\lambda_p}{2} = \frac{\beta \lambda}{2} . \quad (7)$$

4. CAVITY RESONATORS

4.1 Definitions and assumptions

A volume of perfect dielectric limited by infinitely conducting walls can be considered as the ideal cavity resonator. A significant step towards the real case is the introduction of losses inside the resonator. This can be done by assuming that both the walls and the dielectric are lossy. In order to simplify the mathematical treatment, we will assume that the dielectric is homogeneous, linear, time invariant with a finite conductivity s . That is: only the dielectric is lossy. Moreover we will assume that the charges and the impressed current are zero inside the volume. With these assumptions the Maxwell equations become:

$$\begin{aligned} e = 0 ; \quad h = 0 \\ \langle e = -\mu \frac{fh}{ft} ; \quad \langle h = \sigma e + \varepsilon \frac{fe}{ft} . \end{aligned} \quad (8)$$

Making the curl of the third equation and substituting from the fourth, we obtain:

$$\langle \langle e = -\frac{f}{ft} \sigma e + \varepsilon \frac{fe}{ft} \mu .$$

Expanding, taking into account the vector identity:

$$\langle \langle A = \nabla^2 A - \nabla(\nabla \cdot A)$$

and using the first equation we obtain:

$$\nabla^2 e = \mu \sigma \frac{fe}{ft} + \varepsilon \mu \frac{f^2 e}{ft^2} . \quad (9)$$

This equation must be solved with the following boundary conditions:

$n \times e = 0$ because the e field should be normal to the perfectly conducting walls.

$\nabla \cdot e = 0$ because no charges are present inside the volume.

4.2 Mathematical tools

The vector eigenfunction $E = E(x_1, x_2, x_3)$ satisfying the problem:

$$\begin{aligned} \nabla^2 E + \Lambda^2 E = 0 \\ E = 0 \\ n \langle E = 0 \text{ on the boundary} \end{aligned} \quad (10)$$

exists for an infinite, discrete set of real values Λ_n . The eigenfunctions E_n constitute a complete set of orthogonal functions capable of representing any divergenceless vector $A = A(x_1, x_2, x_3)$ perpendicular to the boundary. Consequently we write:

$$\begin{aligned} A = \sum_n c_n E_n \\ \nabla^2 A = -\sum_n c_n \Lambda_n^2 E_n \end{aligned} \quad (11)$$

where c_n are constants and A is time invariant.

If we assume that A depends on the time: $A = A(x_1, x_2, x_3)j(t)$, then we have to substitute the constants c_n with appropriate time dependent functions:

$$a_n = a_n(t). \quad (12)$$

4.3 Solution of the wave equation

We rewrite Eq. (9):

$$\Delta^2 e = \mu\sigma \frac{fe}{ft} + \varepsilon\mu \frac{f^2 e}{ft^2}.$$

and expand the vector "e" according to (11) and (12):

$$e = \sum a_n E_n ; \quad \Delta^2 e = -\sum a_n \Lambda_n^2 E_n$$

Substituting and factorizing the E_n :

$$\sum \left[\varepsilon\mu \frac{f^2 a_n}{ft^2} + \mu\sigma \frac{fa_n}{ft} + \Lambda_n^2 a_n \right] E_n = 0 \quad (13)$$

Since the $E_n \neq 0$, then (13) can be satisfied if, and only if, each of the bracketed terms is identically zero. This means that each function a_n must be defined by the equation:

$$\ddot{a}_n + \frac{\sigma}{\varepsilon} \dot{a}_n + \frac{\Lambda_n^2}{\sqrt{\varepsilon\mu}} a_n = 0 \quad (14)$$

together with the initial conditions. From (14), we immediately conclude that each a_n must be a damped sine wave.

Now we recognize that in a real cavity the losses are due to many factors:

- The introduction of devices for exciting the cavity and for measurements.
- The introduction of lossy dielectrics and, above all, the finite conductivity of the metallic walls.

Because the walls are not perfectly conducting, the condition $n \times e = 0$ is no longer exact even if, normally, the error is negligible. For this reason the above theory is acceptable, but total losses should be expressed by some equivalent conductivity. This can be done using the quality factor (see Appendix 1) and (14) becomes:

$$\ddot{a}_n + \frac{\omega_n}{Q_n} \dot{a}_n + \omega_n^2 a_n = 0 \quad (15)$$

where $\omega_n = \frac{\Lambda_n}{\sqrt{\varepsilon\mu}}$ is the resonant angular frequency of the same cavity when the losses go to zero (that is $Q_n = \infty$). Solving (15), we obtain:

$$a_n = e^{-\frac{\omega_n t}{2Q}} \{ A_1 \cos \Omega_n t + A_2 \sin \Omega_n t \} \quad (16)$$

where:

$$\Omega_n = \omega_n \sqrt{1 - \frac{1}{4Q^2}} \quad (17)$$

is the angular frequency of free oscillation (see Appendix 2) and A_1, A_2 are numerical constants, which depend upon the initial conditions.

4.4 Conclusions

- The electromagnetic field contained by an undriven lossless cavity can be interpreted as the sum of discrete resonant configurations (standing fields) which are known as the modes.
- The modes are only the divergenceless eigenfunctions of the Laplacian operator which fits the boundary conditions.
- The resonant frequency ω_n of each mode depends upon the eigenvalue corresponding to the eigenfunction E_n which characterizes the mode:

$$\omega_n = \frac{\Lambda_n}{2\pi\sqrt{\epsilon\mu}} .$$

- If the cavity is lossy (as is always the case) then an attenuation constant should be associated with each mode:

$$\alpha_n = \frac{\omega_n}{2Q_n} .$$

- The treatment of a cavity driven by an induced current can follow the same lines but current J which appears in the Maxwell equation becomes:

$$J = J_{\text{losses}} + J_{\text{induced}} .$$

- This means that, depending upon the induced current, any frequency can be present inside a driven cavity. Moreover "all the coupled modes" are excited, with different amplitudes and phases.
- When the frequency of the injected current is "practically" coincident with the frequency of one mode, then the amplitude of this mode becomes dominant.
- What we have seen is valid for cavities of any shape. The most used, in practice, are the trirectangular and cylindrical cavities.
- In the following we will deal with the cylindrical cavities that are, by far, the most used in particle accelerators.

5. THE CYLINDRICAL CAVITY

Normally this cavity (see Fig. 3) is used in the accelerating $\text{TM}_{0\ell m}$ mode. This means that the electric field should not have azimuthal variations and that component E_j should be zero.

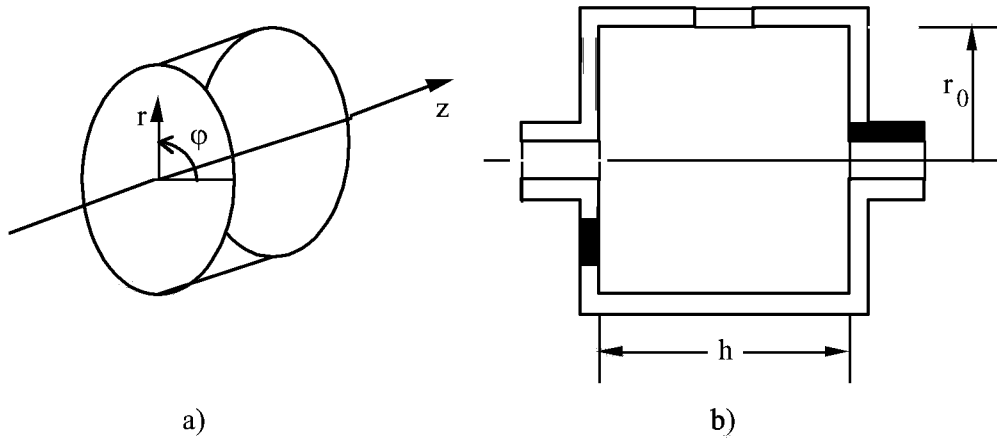

Fig. 3 a) Axonometric view (with the reference versors) of the ideal cylindrical cavity.
 b) Axial section of a real cylindrical cavity where the hole for the coupling and the cut-off axial tubes are shown.

With the above conditions Eq. (10) is easily solvable (see appendix 3) and we obtain:

$$\begin{aligned}
 E_z &= E_0 J_0 \frac{P_{0\ell}}{r_0} r \cos \frac{m\pi}{h} z \\
 E_r &= E_0 \frac{m\pi r_0}{P_{0\ell} h} J_1 \frac{P_{0\ell}}{r_0} r \sin \frac{m\pi}{h} z \\
 \Lambda_{0\ell m}^2 &= \frac{P_{0\ell}}{r_0} + \frac{m\pi}{h}^2
 \end{aligned} \tag{18}$$

where J_0 and J_1 are, respectively, the Bessel functions of order zero and of order one while $P_{0\ell}$ is the ℓ^{th} zero of the Bessel function of order zero.

It is interesting to observe that (see Fig. 4):

- a) If $\ell = 1$ and $m = 0$ then we have the fundamental accelerating mode and the lines of force are straight, without any variation along z , and the resonant frequency does not depend upon the length h of the cavity. Because $P_{01} = 2.405$ we obtain:

$$\begin{aligned}
 E &= E_0 J_0 \frac{2.405}{r_0} r \quad ; \quad \Lambda_{010} = \frac{2.405}{r_0} \quad , \quad \omega_{010} = \frac{\Lambda_{010}}{\sqrt{\epsilon\mu}} \\
 \nu_{010} &= \frac{\omega_{010}}{2\pi} = \frac{1.147 \cdot 10^9}{r_0} \quad ; \quad \lambda_{010} = \frac{1}{\nu_{010} \sqrt{\epsilon\mu}} = \frac{2\pi}{\Lambda_{010}} = 2.61 r_0
 \end{aligned}$$

- b) If, with $\ell = 1$, we make $m = 1$ then the component E_r steps in and from (18) we obtain:

$$E_z = E_0 J_0 \frac{2.405}{r_0} \cos \frac{\pi}{h} z$$

$$E_r = 1.306 \frac{r_0}{h} E J_{10} \frac{2.405}{r_0} r \sin \frac{\pi}{h} z$$

$$\Lambda_{011} = \sqrt{\frac{2.405^2}{r_0^2} + \frac{\pi^2}{h^2}} ; \quad \lambda_{011} = \frac{2.61 r_0}{\sqrt{1 + 1.706 \frac{r_0^2}{h^2}}}$$

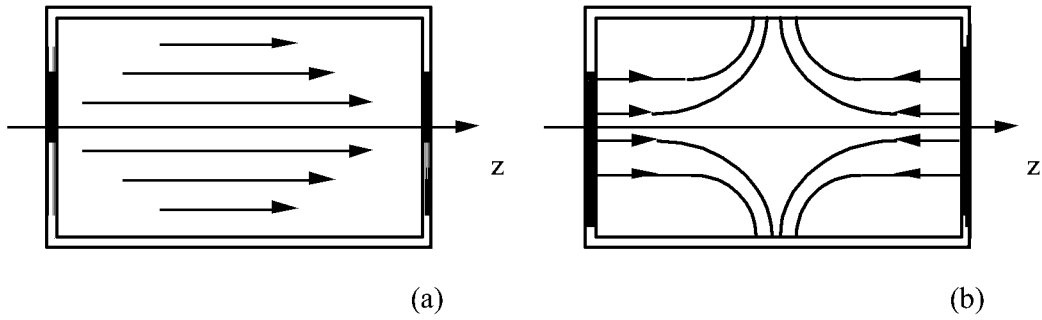

Fig. 4 Lines of force for the electrical field as in modes TM_{010} (a) and TM_{011} (b)

It should be noted that in case (b) the cavity length contains one half of the cavity wavelength: $h = \frac{\lambda}{2}$ where l_g must not be confused with the free space wavelength l .

6. TEM CAVITIES

The pill-box cavity, (and its derivations), solves our problem of creating a gap where the accelerating field can be confined.

Another class of resonant cavities is based on the uniform transmission line, the most common example of which is the coaxial cable (Fig. 5). For this kind of transmission line, inductance L and capacitance C , per unit of length, are as follows:

$$L = \frac{\mu}{2\pi} \ln \frac{R_2}{R_1} ; \quad C = \frac{2\pi\epsilon}{\ln \frac{R_2}{R_1}} . \quad (19)$$

For any kind of uniform transmission line, product LC depends only upon the permittivities of the medium and:

$$V_p = \frac{1}{\sqrt{LC}} = \frac{1}{\sqrt{\epsilon\mu}} \quad (20)$$

is the speed of a signal propagating along a uniform, lossless, transmission line.

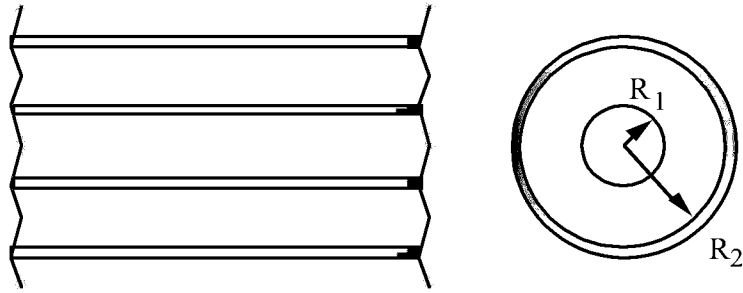

Fig. 5 Axial and normal section of a coaxial cable

For a lossless transmission line the characteristic equations written for the steady state situation (see Appendix 4) are as follows:

$$\begin{aligned} V(x) &= V_L \cos \gamma x + jZ_0 I_L \sin \gamma x \\ I(x) &= I_L \cos \gamma x + j \frac{V_L}{Z_0} \sin \gamma x \end{aligned} \quad (21)$$

where: x is the distance from the load ($x = 0$).

V_L and I_L are respectively the voltage and the current in the load Z_L .

$\gamma = \omega \sqrt{\epsilon\mu} = 2\pi / \lambda$ is the propagation constant and ω is the angular frequency.

$Z_0 = \sqrt{L/C}$ is the characteristic impedance (real) of the line which depends upon the shape of the line and the permittivities of the medium.

In addition to its use for power transmission, an element of line can be used as a pure reactance. The ratio $V(x)/I(x)$ is the input impedance of an element of line terminated on the load Z_L . From Eq. (21) we obtain:

$$Z(x) = Z_0 \frac{Z_L + jZ_0 \tan \gamma x}{Z_0 + jZ_L \tan \gamma x} \quad (22)$$

A very important case is met when $Z_L = 0$ and we obtain:

$$Z(x) = jZ_0 \tan \gamma x \quad (23)$$

So we conclude that a stub of transmission line short-circuited at one end shows the following behaviour:

- Its input impedance can show any reactance.
- If the physical length of the element is equal to $l/4$ then the stub exhibits an infinite (real) impedance and we have the quarter-wavelength resonator.

The above behaviour is used in the TEM (coaxial) resonators. One end of the coaxial line is short circuited ($x = 0$) and the other is connected to the capacity C of the accelerating gap as shown in Fig. 6. The resonant condition is met when $Y = 0$.

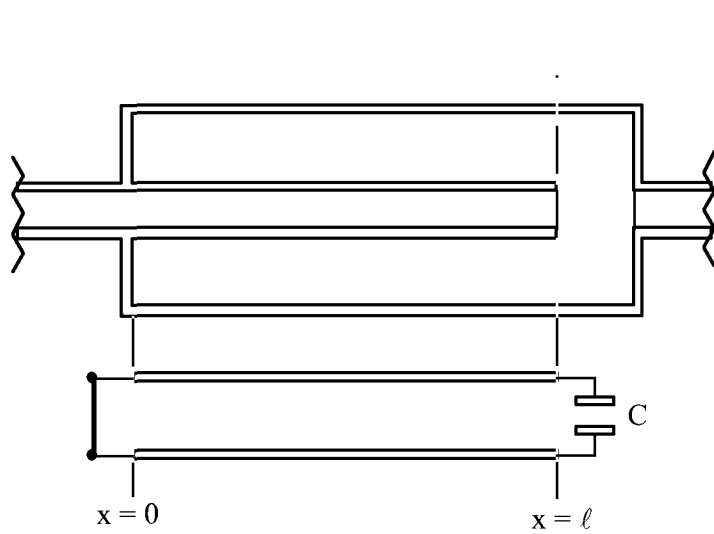

$$v(x) = v_0 \frac{\sin \gamma x}{\sin \gamma \ell}$$

$$I(x) = -j \frac{v_0 \cos \gamma x}{Z_0 \sin \gamma \ell}$$

$$Y = j\omega C + \frac{1}{jZ_0 \tan \gamma \ell}$$

$$\gamma = \frac{2\pi}{\lambda} = \frac{2\pi}{V_p T} = \frac{\omega}{V_p}$$

If $\mu = \mu_0$ and $\epsilon = \epsilon_0$ then $V_p = 1/\sqrt{\epsilon\mu}$ coincides with the speed of the light.

Fig. 6 The foreshortened coaxial resonator and its equivalent scheme for the TEM modes

7. $l/2$ CAVITY (Fig. 7)

In this case the E fields at the two gaps must be 180° apart and this means that the two ends should oscillate in phase. This cavity is devised to "contain" the drift tube, so reducing the losses and eliminating the radiation. It is made with a piece of coaxial line loaded at the two ends with the capacity of the gap, and at the center with the output capacity of the driving tube.

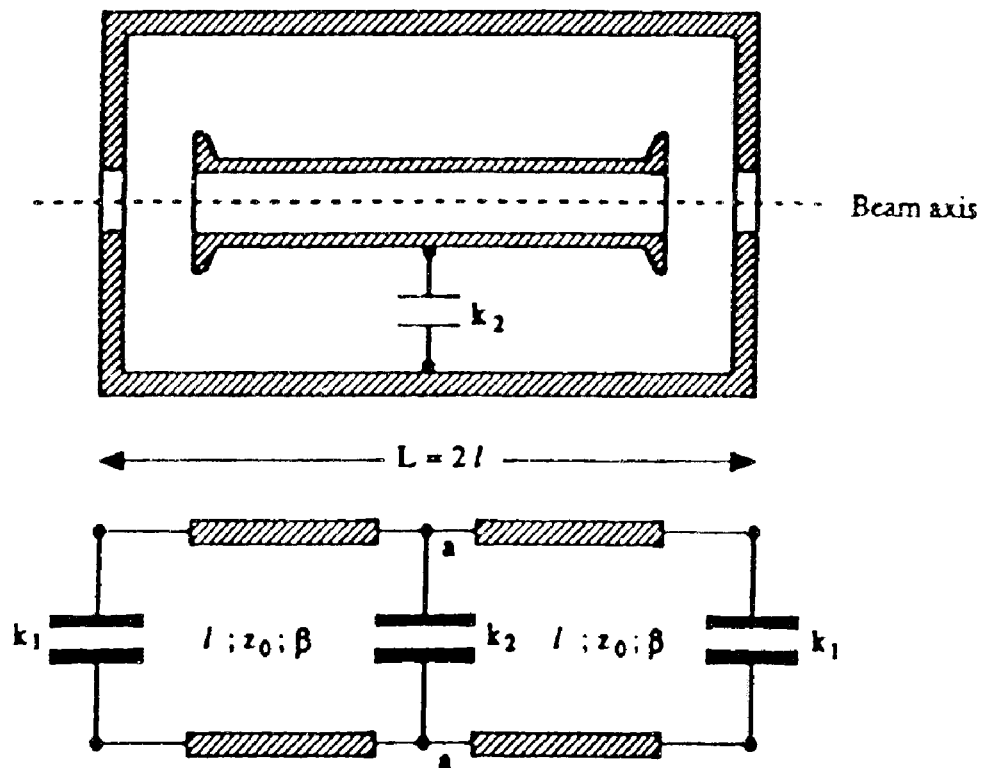

Fig. 7 Simplified axial section and equivalent scheme of the $l/2$ cavity

The resonant frequency of this cavity can be determined with a very simple procedure. The equivalent circuit can be bisected along "aa" and we obtain two identical circuits where, instead of capacitor k_2 , we have capacitor $k_2/2$. Then we consider the admittance Y of the stub connected, at one end, to capacitor k_1 .

$$Y = \frac{1}{Z_0} \frac{Z_0 + jZ_L \tan \gamma \ell}{Z_L + jZ_0 \tan \gamma \ell} = \frac{1}{Z_0} \frac{Z_0 + \frac{1}{\omega k_1} \tan \gamma \ell}{\frac{1}{j\omega k_1} + jZ_0 \tan \gamma \ell} .$$

$Y_t = j\omega \frac{k_2}{2} + Y$ is the total admittance of each stub and the resonant condition is met when $Y_t = 0$.

$$Z_0 \omega \frac{k_2}{2} + \frac{\omega k_1 Z_0 + \tan \gamma \ell}{1 - \omega k_1 Z_0 \tan \gamma \ell} = 0 .$$

Length $L = 2\ell$ of the drift tube is assigned together with the output capacity of the tube. Consequently the capacity k_1 of each gap together with the value of Z_0 must be chosen according to the resonant condition.

8. RE-ENTRANT CAVITY

This cavity (Fig. 8) can be considered as being derived from the pill box-cavity or from a foreshortened coaxial cavity. In many particle accelerator and specialized books it is considered as the limit of a resonant device made of many identical loops connected to two parallel disks. When the number of loops becomes infinite the device is completely closed and becomes a resonant cavity.

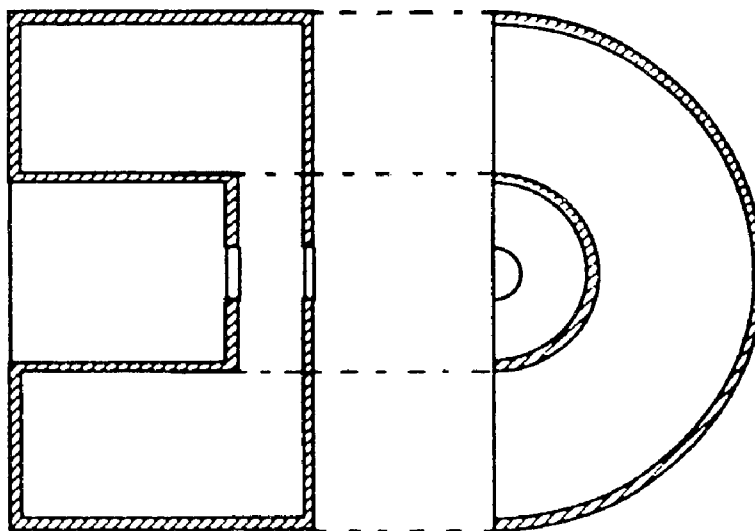

Fig. 8 Axial and equatorial section of a re-entrant cavity

The resonant frequency of this cavity can be studied rigorously (and it is a complicated study) but it can be also approximated with a very simple procedure. Consider Fig. 9 where the magnetic circuit is defined by the cylindrical sleeves of radii r_1 and r_2 limited by the two circular crowns separated by distance k . The currents injected onto the inner walls by the capacitor create a flux f whose lines of force are circular and centered on the axis of the cavity. If the cross section of the toroid is approximately square and if we suppose that the magnetic field obeys the Biot-Savart law then the flux passing through the cross section dA of a cylindrical crown with thickness equal to dr is:

$$d\phi(r) = \mu_0 H(r) dA = \mu_0 \frac{I}{2\pi r} k dr$$

where I is the peak of the alternating current due to the capacitor. The total flux is obtained by integration. Taking into account that:

$$L = \phi/I$$

we obtain:

$$L = \frac{\mu_0}{2\pi} k \ln \frac{r_2}{r_1} .$$

If $\epsilon_0 \pi r_1^2 / d$ is the capacity due to the central disk we obtain for the resonant frequency:

$$f_0 = \frac{1}{2\pi\sqrt{LC}} = \frac{1}{2\pi\sqrt{\epsilon_0\mu_0 r_1 \frac{k}{2d} \ln \frac{r_2}{r_1}}} = \frac{0.225}{r_1 \sqrt{\epsilon_0\mu_0 \frac{k}{d} \ln \frac{r_2}{r_1}}} .$$

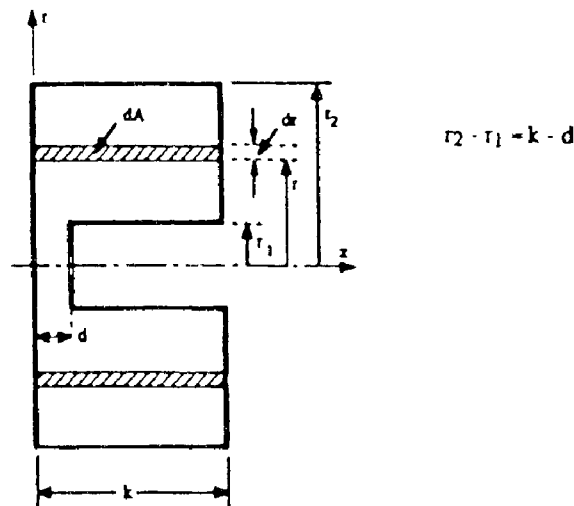

Fig. 9 Cross section of 'LC' cavity with the gap on one side

It should be emphasized that the heuristic procedure already outlined cannot give a very good approximation unless special geometrical conditions are fulfilled. In fact:

- i) The fringing field around the capacitor has been ignored but the contribution of this field to the total capacity may be large.
- ii) The magnetic field in the cross section is a function both of r and z . Consequently the use of the Biot-Savart law may result in a very naive approximation.
- iii) It is immediately seen, from the Maxwell equation, that the magnetic field cannot be zero inside the capacitive region. Similarly, the electric field cannot be zero inside the inductive, or H , region.

In Fig. 10 three examples of LC cavities are indicated together with the lines of force of the electric fields and the value of the resonant frequencies. (The sizes of the cavities are $r_2 = 0.40$ m, $r_1 = 0.10$ m, $k = 0.3$ m. The gaps are 0.01, 0.02 and 0.06 meters for a), b) and c) respectively.)

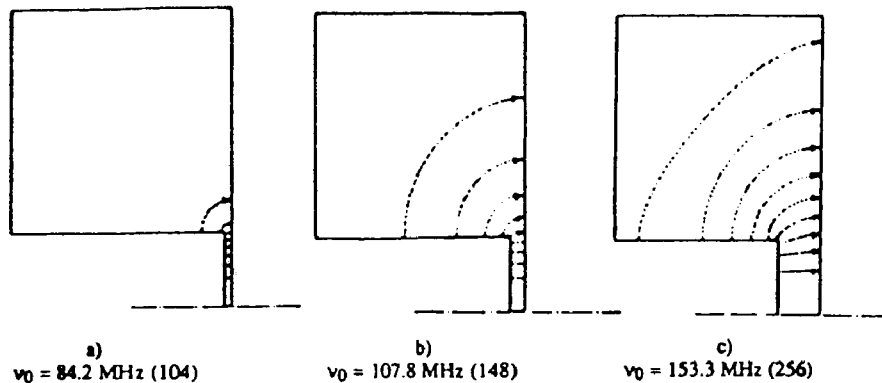

Fig. 10 Three different profiles of LC cavities (the cavities are symmetric and only half the section is shown). ν_0 is the resonant frequency from a computer program while the value between parenthesis comes from the analytical formula.

9. COMMON RF ACCELERATING STRUCTURES

9.1 Drift-tube (Alvarez) structures

As we have seen, the cavity resonator is a powerful device which can "contain" the RF fields with very small losses so preventing irradiation of the chamber by the particles being accelerated. The ideal situation is shown in Fig. 11 where the "charged particle" sees the field only when it is inside the gap. This situation can be developed in many ways which end in the creation of many gaps inside one cavity driven at resonance.

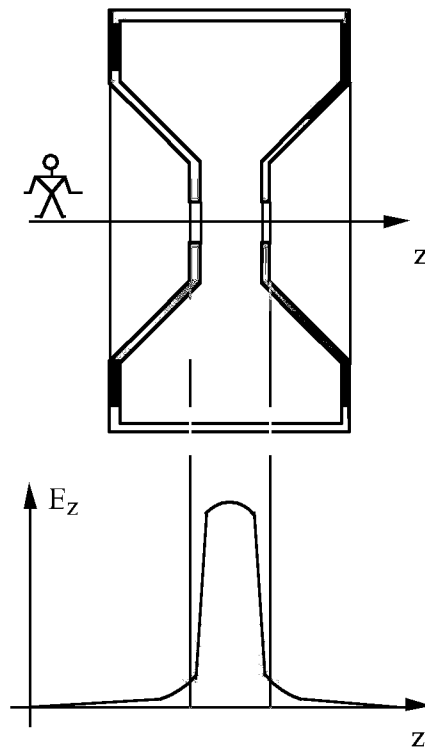

Fig. 11 Field in a resonant cavity

If the number of gaps is small then the device is called an "accelerating structure". If the number of gaps is large, or very large, then the structure is known as a "linear accelerator". When we deal with particles with low β , the gaps are made from "drift-tubes" as shown in Fig. 12, which is the so-called Alvarez cavity, named after its inventor.

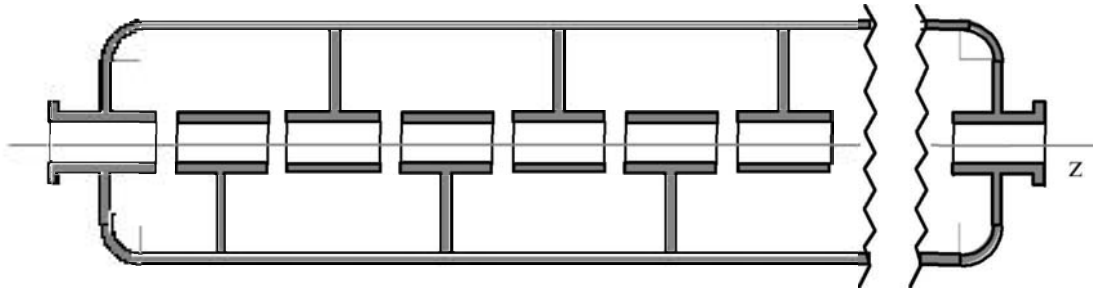

Fig. 12 Sketch of the Alvarez cavity

If the structure is operated in the TM_{101} mode then all the gaps are excited in phase and the length L of each drift tube should be:

$$L \cong \beta CT = \beta \lambda = \lambda_p$$

where l_p is the distance covered by a particle during one period of the RF field.

Obviously other modes of resonance are possible for this device. If the fields in the gaps oscillate in anti phase then the length of each drift tube should become:

$$L = \beta C \frac{T}{2} = \beta \frac{\lambda}{2} = \frac{\lambda_p}{2} .$$

For the previous mode the supports of the drift tubes should not carry any RF current while for the latter mode they become a fundamental part of the structure. (This is evident looking at the figures in Appendix 5.)

9.2 Corrugated structures

This topic is vast, complex and cannot be summarized without some knowledge of wave-guides (see Appendix 6) and periodic-structures theory. Consequently here we remain within the limit of a simple and heuristic presentation.

Consider a pill-box cavity modified as shown in Fig. 13 a) and b). If the ring which loads each cavity is very small, then it can be treated as a small perturbation of the original pill-box cavity and we can recognize that the indicated modes are the TM_{101} and TM_{011} respectively. In reality the loading rings are much more than a simple perturbation and the resonant frequencies change accordingly. It is evident that for relativistic particles ($\beta \sim 1$) the second mode of operation is more effective. Resonant cavities with many cells have been made in this way including the super conducting cavities.

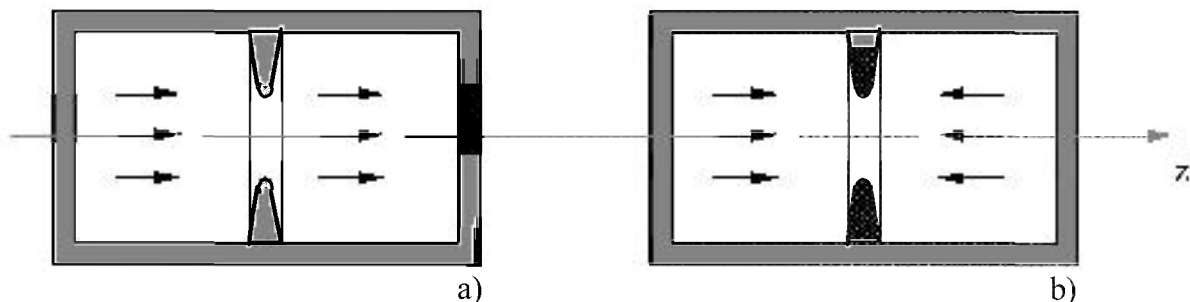

Fig. 13 E_z component for the modes of oscillation zero and π

In the above example the coupling between adjacent cavities depends upon the thickness and the inner radius of the rings (the washers) and the coupling is mainly capacitive.

Large fields demand a small inner radius of the rings and the consequent small coupling may be intolerable in view of the overall efficiency of the structure. The introduction of "inductive coupling" improves the situation as shown in Fig.14.

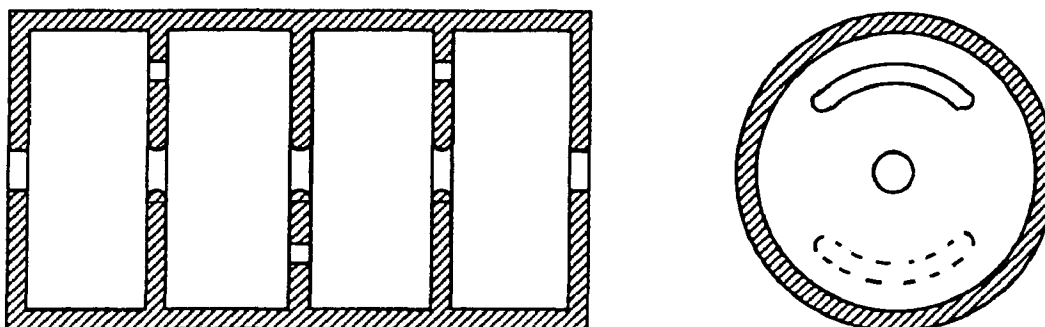

Fig. 14 Axial and normal section of an accelerating structure made of two half and two full cavities mostly inductively coupled

9.3 Linacs

The accelerating structure described above is resonant and for technical reasons cannot be made of very many cavities (the number of possible modes of oscillations increases with the number of elements). However, it is perfectly possible to build a structure "similar" to the one shown in Fig. 14 where the last short-circuiting wall is substituted with a matched load and the RF power is supplied at the first cell, also with a matched coupling. (This means that the reflection at both ends is eliminated.) In this situation the structure does not resonate whereas it can propagate an electromagnetic wave from the first to the last cell (with small losses). This wave can efficiently accelerate the charged particles if the phase velocity V_p of the wave is equal to the speed of the particles (for electrons or positrons $V_p = c$).

A matched structure is less critical than the corresponding resonant one and can be made with a large number of cavities. The latter are known as travelling wave linacs and are known to be very efficient. Structures working at 3000 MHz and containing ~240 cavities have been constructed, and 200 MeV per structure are now possible (34 MeV/meter).

10. COUPLING TO THE CAVITIES

10.1 Magnetic coupling

Here the electrical power excites a loop that is coupled to the cavity. This means that the magnetic field created by the loop should have a component in common with the magnetic field of the mode we wish to excite in the cavity. As shown in Fig. 15, the loops are placed in the region of the cavity where the magnetic field is stronger.

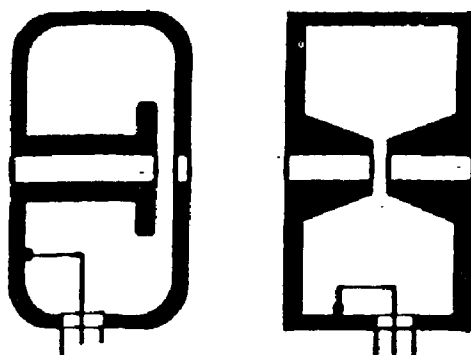

Fig. 15 Two examples of loop coupling

10.2 Electric coupling

In this case a capacitive coupling is created by placing the exciting electrode where the electric field is stronger. This coupling is simple and efficient but creates high field gradients which must be carefully evaluated to avoid the risk of dark and/or glow discharges.

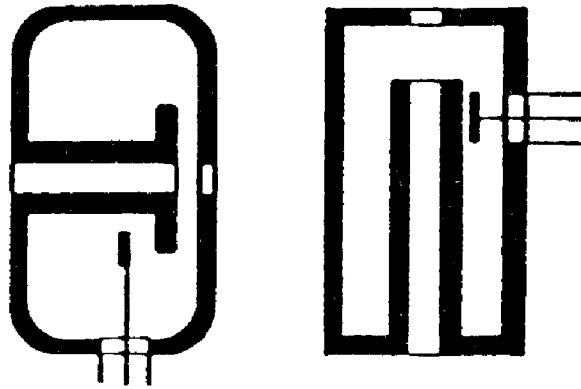

Fig. 16 Two examples of electric coupling

10.3 Direct coupling

In this case the generator is connected directly to the cavity. This may be convenient if, avoiding the transmission line, the plate or the cathode of the final tube can be directly connected with the "hot" electrode of the cavity.

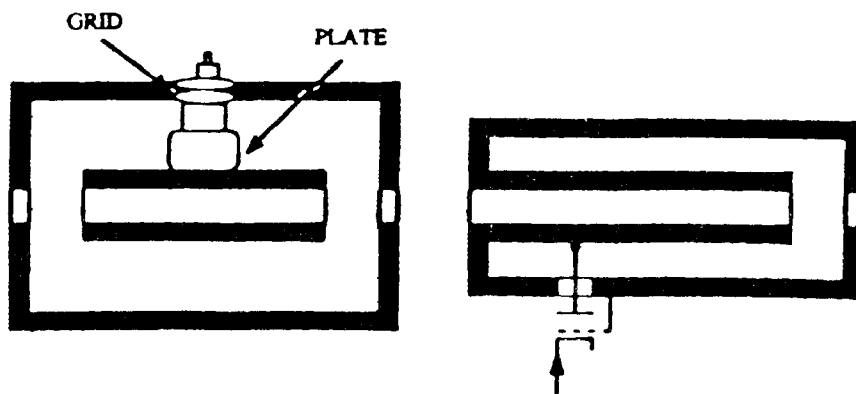

Fig. 17 Two examples where the plate of the final tube is directly connected to the "hot" electrode of the cavity

An intermediate situation is indicated in Fig. 18, which is self explanatory. (The "tuning magnet", operated with an external current, changes the permittivity of the ferrite and allows a continuous tuning of the cavity.)

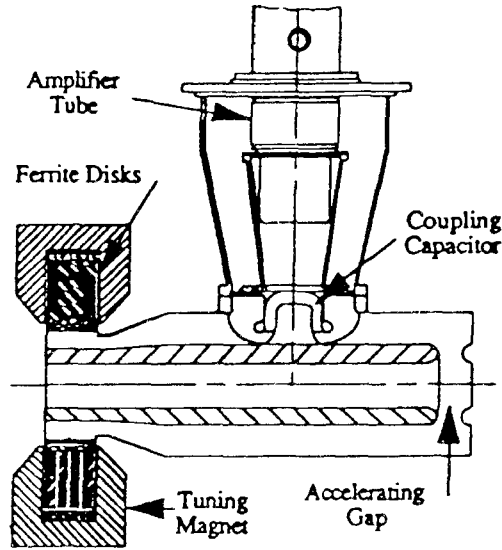

Fig. 18 Accelerating cavity for the SSC Low-Energy Booster [1] © 1991 IEEE

11. SHUNT IMPEDANCE

This is an important topic for the whole RF field. Basically we can say that the shunt impedance R_{sh} (always a real quantity) of an RF structure is the parameter which relates the level of excitation of the structure with the power W which has to be provided. The determination of R_{sh} depends upon the fact that, for each *arbitrary* selected pattern ℓ inside the structure, a voltage V can be defined and considered as the measure of the excitation level.

$$V = \int_{\text{pattern}} |E(x, y, z)| d\ell$$

and consequently:

$$R_{sh} = \frac{V^2}{2W} .$$

For a first determination of W it is common practice to evaluate the linear density (amp/meter) of the current j along the walls of the selected structure. First the walls are considered to be lossless and then the losses are introduced taking into account the finite conductivity s of the walls.

Since for a perfect conductor we have $j = n \times H$, then:

$$W = \frac{R_s}{2} \int_s |H|^2 ds$$

where s is the inner surface of the structure and $R_s = \sqrt{\pi\nu\mu/\sigma}$ is the familiar surface resistance of an imperfect conductor (for copper $R_s = 2.61 \cdot 10^{-7} \sqrt{\nu} \Omega$).

12. RF POWER AMPLIFIERS

- 1) The power needed to drive the accelerating structures ranges between a few kilowatts and a few megawatts (c.w.).
- 2) The wave shape is always sinusoidal. Amplitude and frequency modulation may be requested.
- 3) Due to these facts tuned amplifiers are always used (both for narrow and broad band operation).
- 4) The tuned amplifier is used because it has high efficiency and allows the generation of sinusoidal carriers independently upon the shape of the current inside the tube.
- 5) In a tuned amplifier both the input and the output circuits should be resonant (tuned).
- 6) Sometimes the RF output circuit is the accelerating structure (resonant).

The basic elements of most RF power amplifiers are the triode or the tetrode with which it is possible to cover a frequency range from a few to a few hundred megahertz. At higher frequencies another device is preferred: the klystron. As will be shown later, this is an electron device which, by its own nature, is an amplifier. Both the electron tube and the klystron are considered as RF generators.

13. RF GENERATORS

13.1 Introduction

RF generators constitute a "universe" similar to our own in that it is expanding and contains galaxies. In fact it contains very many groups of elements with something in common but, on the other hand, far apart from each other technically speaking.

The dawn of the modern RF generators started with the invention of the triode by L. de Forest in 1906, a discovery of so great practical importance that it made the electronic industry possible. The actual industrial frontier is represented by the Gyrotron which is a powerful generator in the range of the millimetric waves while the very promising free electron laser is still under laboratory development.

It is important to notice that each new class of generators does not render the previous ones obsolete. This is due to the different applications for which the generator is required. For instance, triodes are still commonly manufactured together with other more modern devices.

13.2 Triode amplifier

It is well known that in a triode, the current I_a depends upon the plate and the grid voltages referred to the cathode. Let V_{pk} and V_{gk} be those voltages. Roughly the anode current obeys the "adapted" Langmuir-Child law:

$$I_a = k(V_{pk} + \mu V_{gk})^{3/2} \quad (24)$$

where k is the perveance of the tube and μ its amplification factor. Unfortunately these parameters are not constant (because they depend upon the current) and should be considered as average values. For this reason the characteristics of each tube provided by the manufacturers should be carefully studied for each application.

The power handling capacity of a triode can be very large. For instance assume the typical values for large triodes $\mu = 40$ and $k = 3 \cdot 10^{-5} (A/V^{1.5})$. Then with a minimum $V_{pk} = 2000$ V while the grid attains its maximum, say $V_{gk} = 300$ V, the plate current is ~ 50 A and the instantaneous input power is 100 kW. The relation:

$$I_a = f(V_{pk}, V_{gk}) \quad (25)$$

between the anode current and the voltages applied to the tube is normally given by graphics. The most used for the design of the power RF amplifier is the graphic of the lines of "constant currents" in the plane of the anode and grid voltages. An example of the constant current characteristic for a medium power tube is given in Fig. 19 and it is evident that the "useful" anode current must be contained between the cut-off and the diode (dotted) lines.

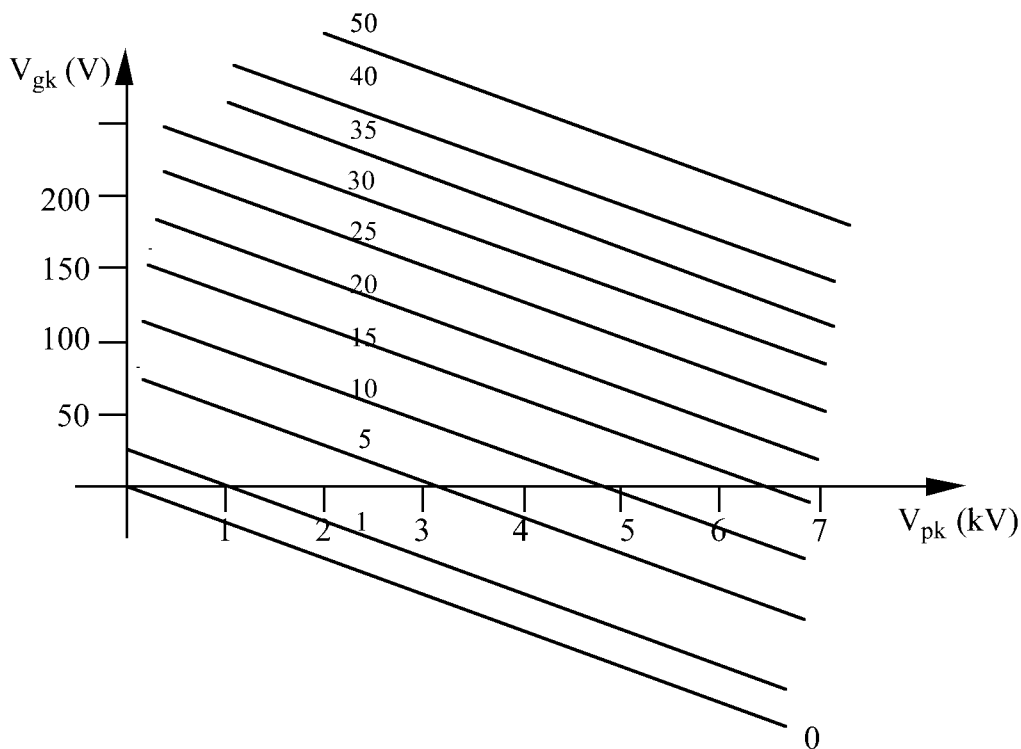

Fig. 19 Constant current characteristic of a medium-power tube

Usually the voltages V_{pk} and V_{gk} are resolved into the components:

$$V_{pk} = E_p + V_p ; \quad V_{gk} = E_g + V_g$$

where E_p and E_g are the polarization (bias) voltages and V_p , V_g are the variations around E_p and E_g (the quiescent point) corresponding to the signals. Then Eq. (25) is expanded, with the Taylor series, around the quiescent point and the anode current becomes:

$$I_a = I_0 + I_p$$

where I_0 and I_p are the static and the dynamic components of the anode current. (The reader should be aware of the fact that I_0 depends upon both the quiescent current and the other terms of the series).

If we assume that:

$$E_p \gg |V_p| ; \quad |E_g| \gg |V_g| \quad (\text{small signals theory})$$

then the higher-order terms of the series can be neglected and we write:

$$I_p = \frac{fI_p}{fV_p} V_p + \frac{fI_p}{fV_g} V_g = \frac{1}{\rho} V_p + G_m V_g \quad (26)$$

where r (the plate resistance) and G_m (the transconductance) are constants in a small range around the quiescent point. The product $G_m r = \mu$ is the familiar amplification factor. From Eq. (26) it is immediately evident that in a circuit the triode can be replaced by its equivalent circuits as shown in Fig. 20a) and 20b), where the inter-electrode static capacities are considered.

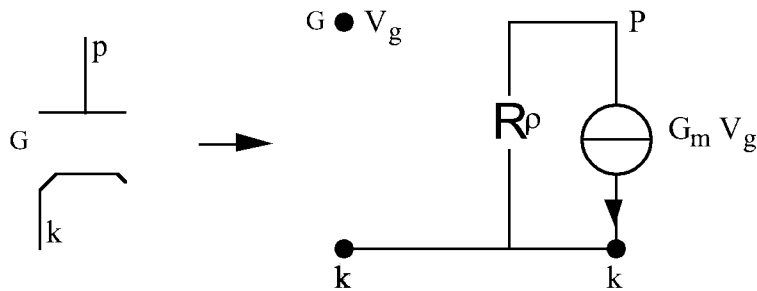

Fig. 20a)

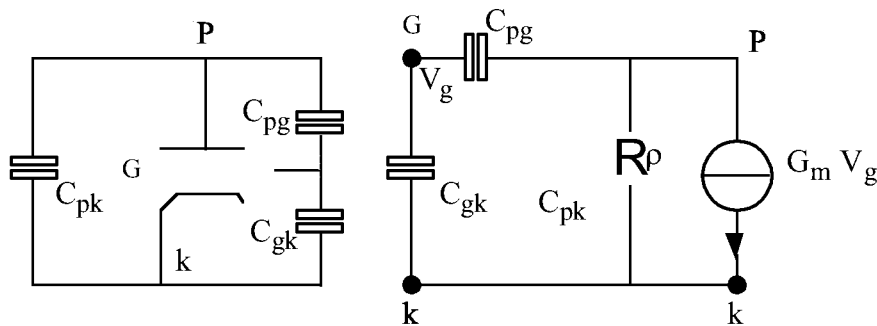

Fig. 20b)

The basic scheme of a tuned amplifier is given in Fig. 21, where the "normal" operating conditions are indicated.

$$Z = \frac{R_{eq}}{1 + jQ \left(\frac{F}{F_0} - \frac{F_0}{F} \right)}$$

For the tuned case we have:

$$V_{pk}(t) = E_p + V_p \sin \omega t$$

$$V_{gk}(t) = E_g + V_g \sin \omega t$$

In this case the load line is straight and it is defined by the four voltages E_p, E_g, V_p, V_g . The load line crosses the constant current characteristics and the anode current is determined. The fundamental component of this current should be consistent with the anode voltage V_p and with the value of R_{eq} . The diagrams illustrate a class C_2 operation. The output circuit always has a quality factor so high that the higher-order harmonics of the anode current has a negligible effect on the anode signal which remains sinusoidal.

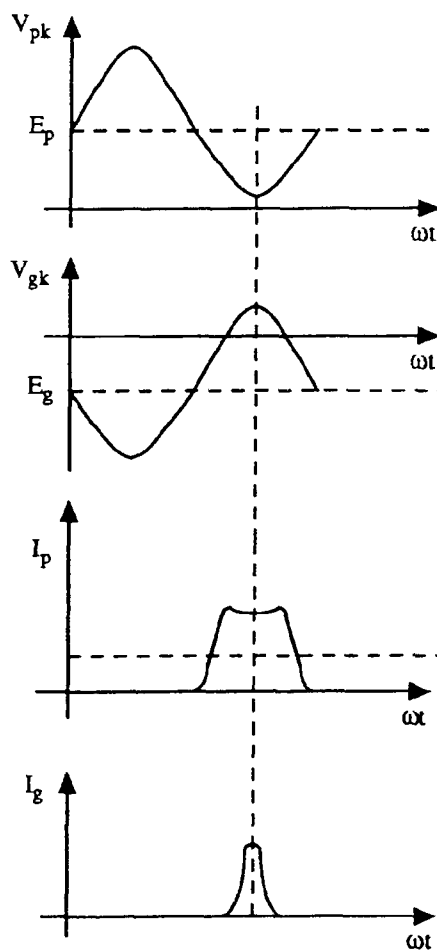
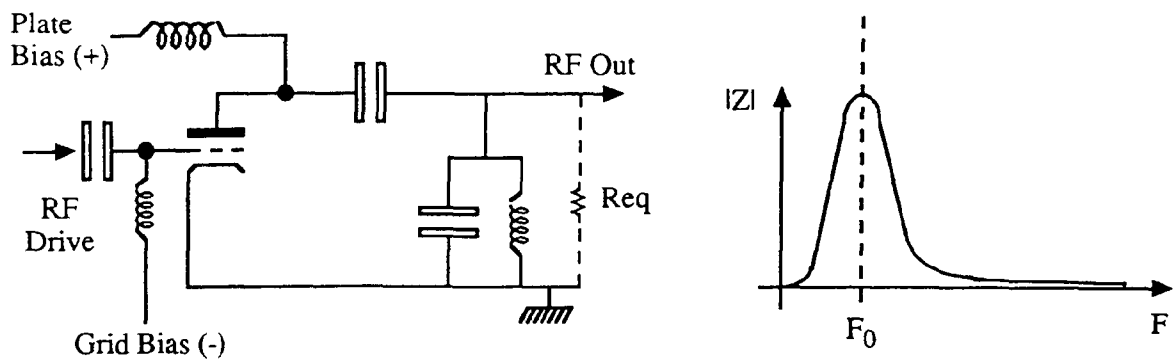

Fig. 21 Characteristics of a tuned amplifier

13.3 Internal feedback

This is due to the unavoidable internal capacities. To alleviate this problem the tetrode was invented where the grid and the plate circuits are separated by the screen grid which, normally, is held at constant voltage. In any case some form of neutralization is required and one important example of a neutralized circuit (for frequencies below ~ 50 MHz) is given in Fig. 22, where as indicated, the grid and the plate circuits are on the two diagonals of a bridge. Balancing the bridge the two circuits ignore each other and neutralization is achieved.

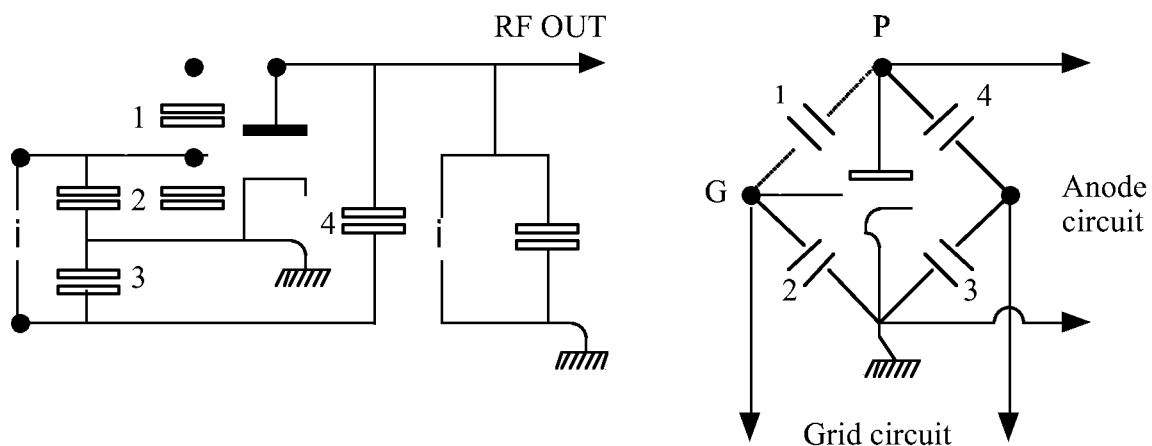

Fig. 22 Neutralized circuit

The most common solution (for triodes and tetrodes) at higher frequencies is the grounded-grid configuration shown in Fig. 23 with its equivalent circuit.

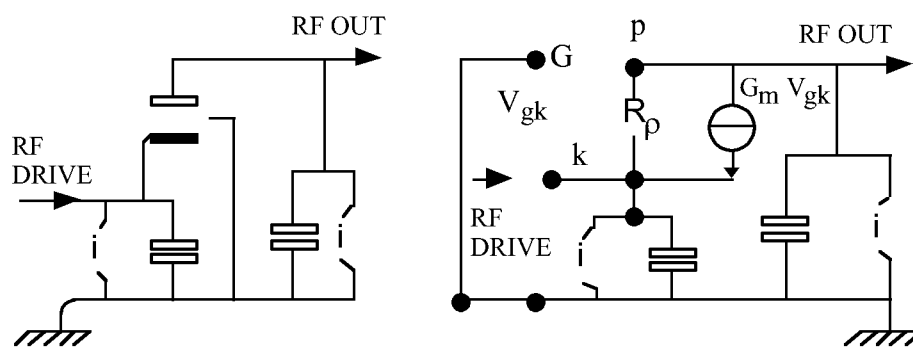

Fig. 23 Grounded-grid configuration

Note that:

- 1) The control grid (and for a tetrode also the screen grid) are grounded from the RF point of view. So the residual feedback capacity (between anode and cathode) is very small.
- 2) The RF drive should come from a very low output impedance source ($\leq 50 \Omega$) because we are driving the cathode.
- 3) In the normal situation (plate and cathode circuits tuned to the same frequency) the input and output voltages are in phase.

The mounting scheme of the grounded-grid amplifier, which is normally used in the range from ~ 40 to 250 MHz, is sketched in Fig. 24. It is easy to see that the tube is connected to two foreshortened coaxial resonators which, due to the input and output capacity of the tube are both shorter than $l/4$. The two resonators are tuned by varying the position of the two short circuits at the bottom while the useful power is picked off with a capacitive coupling. The decoupling between the d.c. biases and the a.c. components is ensured by lumped or distributed capacitors.

Some important comments are in order:

- i) The cathode is heated from the central pin of the tube.
- ii) The drive is applied between grid and cathode, normally with a loop coupling.
- iii) Operation is "normally" in class C_2 which means that the quiescent current in the tube is set to zero, that the grid to cathode voltage becomes positive for a short period of the RF cycle and that the plate current is different from zero for less than half a cycle of the RF voltage.

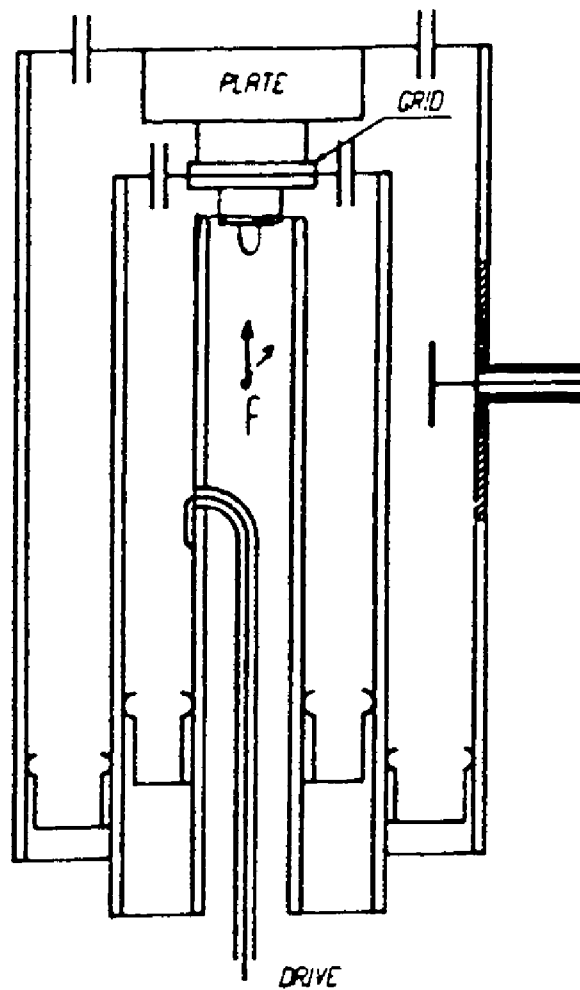

Fig. 24 Grounded-grid amplifier

- iv) The tuned high- Q plate circuit practically filters out all the harmonic components of the plate current.
- v) Sometimes the tube can be mounted directly on the cavity which acts as the resonant anode circuit.
- vi) Tetrodes are used as well as triodes.

13.4 Klystron amplifier

The klystron is a narrow-band, tuned amplifier capable of delivering a very large amount of power with wavelength from about one meter to a few centimeters (while the triode is a wide-band generator which is used to make narrow or wide-band tuned amplifiers). It is inherently a narrow-band amplifier because it relies on the interaction between the electrons emitted by the cathode and two or more cavity resonators. A simplified scheme of a klystron amplifier is given in Fig. 25.

The anode block, always at ground potential, consists of two resonant cavities separated by a drift tube. This block ends with a collector which, normally, is water cooled. Under the anode block there is a ceramic tube which contains the optics capable of creating a powerful electron beam and the cathode. The cathode is supplied with a negative voltage which can be very high (even more than 100 kV). The working principle is as follows:

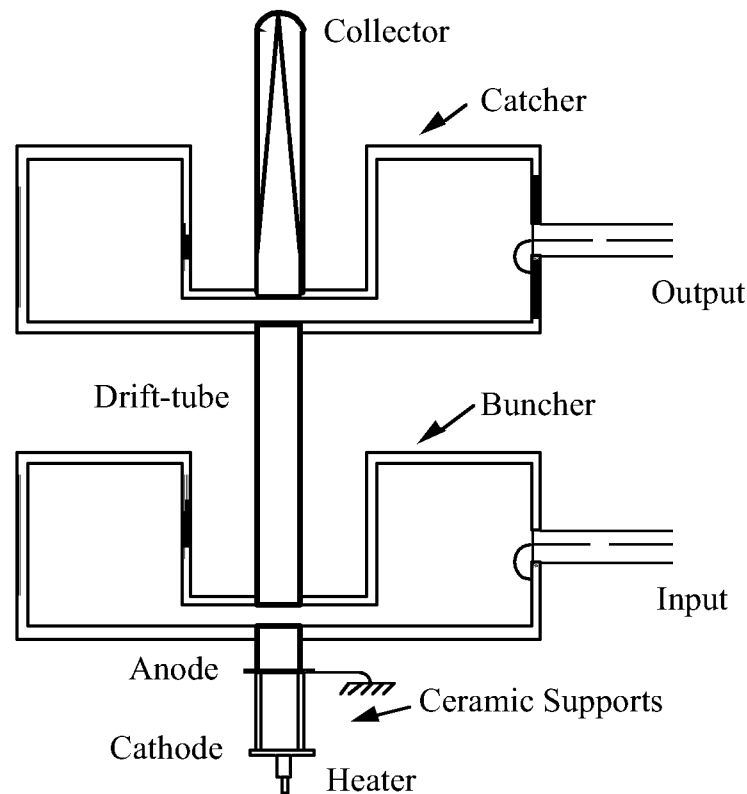

Fig. 25 Schematic of a klystron amplifier

The RF signal to be amplified is sent to the buncher cavity and some voltage is developed at the gap. The continuous electron beam which comes from the cathode enters the gap of the first cavity and the speed of the particles is slightly varied according to the phase of the voltage at the entrance. In this way the uniform beam comes out slightly modulated in velocity. It should be noticed that this operation does not involve energy exchange between the cavity and the beam as long as the entering beam is uniform and the impressed changes in the speed are small. The emergent beam travels along the drift tubes and, due to the differences in speed of the particles, undergoes the process of bunching. (This is a very complicated process especially if the space-charge effects are taken into account.)

At some distance from the buncher a position exists, the first focus, where the electrons arrive in bunches, theoretically with infinite longitudinal density. The gap of the second cavity (the catcher) which becomes excited by the train of bunches (one per period) is placed at this point. The output coupling loop absorbs power from the cavity so its gap voltage remains in the prescribed limits. Having lost the greatest part of their kinetic energy, the bunches inside the catcher are finally absorbed by the collector. In other words: part of the kinetic energy of the electrons coming from the cathode is converted into RF power.

It should be remembered that the above description is an over simplification of the whole phenomenon of the energy conversion in a klystron.

For instance, two or three "idle" cavities, which improve the bunching action, are normally inserted between the buncher and the catcher. Moreover a focusing solenoid is placed along the bunching region.

The pulsed power from an industrial klystron can be as large as 50 MW and for those levels of power a waveguide output is preferred. In continuous-wave operation a power of 1 MW has been reached at 350 MHz.

REFERENCE

- [1] C.C. Friedrichs, L. Walling and B.M. Campbell, Design of an accelerating cavity for the Superconducting Super Collider Low-Energy Booster, Proc. Particle Accelerator Conference, May 6-9, 1991 in California.

BIBLIOGRAPHY

- 1) R.E. Collin, Field Theory of Guided Waves, McGraw Hill, New York (1961).
- 2) C.G. Montgomery, R.H. Dike and E.M. Purcell, Principles of Microwave Circuits, M.I.T. Radiation Lab. Series, Mc Graw Hill, (1948).
- 3) T. Moreno, Microwave Transmission Design Data, Dover Pub. Inc., (1958).
- 4) J.C. Slater, Microwave Electronics, Dover Pub. Inc., (1969).
- 5) S. Ramo, J.R. Whinnery and T. van Duzer, Fields and Waves in Communication Electronics, John Wiley & Sons, (1984).
- 6) E.T. Whittaker and G.N. Watson, A Course of Modern Analysis, 4th ed., Cambridge Univ. Press, Cambridge, England, (1952).

APPENDIX 1

QUALITY FACTOR OF A RESONATOR

We consider a parallel "L-C" circuit, where the inductor L is lossless while the capacitor, with capacity C , is made of two parallel plates (with equivalent surface s and separated by distance d), which contains a dielectric with electrical permittivity ϵ and conductivity σ . (That is $C = \epsilon \frac{s}{d}$.)

For this circuit $\omega = 1/\sqrt{LC}$ is, obviously, the *resonant* angular frequency while if V is the voltage on the circuit then:

$$U_s = \frac{V^2}{2} \epsilon \frac{s}{d} ; \quad U_d = \frac{V^2}{2} \frac{\sigma s}{d} \frac{2\pi}{\omega}$$

are, respectively, the stored energy and the energy wasted per cycle $\frac{2\pi}{\omega} = T$.

Consequently a very simple substitution shows that:

$$\frac{\sigma}{\epsilon} = \frac{\omega}{2\pi} \frac{U_s}{U_d} = \frac{\omega}{Q} \tag{A1.1}$$

where " Q " is the familiar quality factor which characterizes the "quality" of a resonance.

APPENDIX 2

RESONANT FREQUENCY

Resonant frequency $\nu_r = \frac{\omega}{2\pi}$ and the frequency of free (and damped) oscillations $\nu_f = \frac{\Omega}{2\pi}$ of a parallel "RLC" circuit are conceptually very different, even if their values may be extremely close.

Consider the circuit and its equations given below.

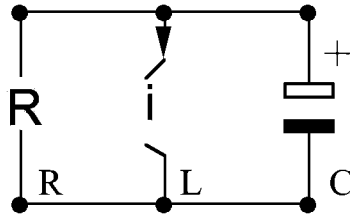

$$\begin{aligned} C \frac{dV}{dt} + \frac{V}{R} + I &= 0 \\ L \frac{dI}{dt} - V &= 0 \end{aligned} \tag{A2.1}$$

The voltage on the capacitor is V and I is the current in the inductor. Solving Eq. (A2.1) and using the normal parameters $\omega = 1/\sqrt{LC}$; $Q = \omega RC$, we obtain the differential equation:

$$\ddot{V} + \frac{\omega}{Q} \dot{V} + \omega^2 V = 0 \tag{A2.2}$$

for which the general integral is:

$$V = A_1 e^{\alpha_1 t} + A_2 e^{\alpha_2 t} \tag{A2.3}$$

where:

$$\alpha_{1,2} = -\frac{\omega}{2Q} \pm j\omega \sqrt{1 - \frac{1}{(2Q)^2}} . \tag{A2.4}$$

Assuming that the initial conditions are:

$$V = V_0 ; I = 0$$

then (A2.2) becomes:

$$V = V_0 e^{-\frac{\omega}{2Q} t} \cos \Omega t - \frac{1}{\sqrt{4Q^2 - 1}} \sin \Omega t \tag{A2.5}$$

where:

$$\Omega = \omega \sqrt{1 - \frac{1}{(2Q)^2}} .$$

It is now evident that when Q becomes very large, then Ω reduces to ω . For instance in a cavity with a loaded Q as low as 100, we obtain:

$$\frac{\omega}{Q} = 1 + 1.25 \cdot 10^{-5} .$$

APPENDIX 3

CYLINDRICAL CAVITY

Because E_ϕ and $\frac{f}{f_\phi}$ are supposed to be zero then:

$${}^2E = a_z {}^2E_z + a_r {}^2E_r - \frac{E_r}{r^2} \quad (\text{A3.1})$$

where, for any scalar ξ , and under the above conditions we have:

$${}^2\xi = \frac{f^2\xi}{fr^2} + \frac{1}{r} \frac{f\xi}{fr} + \frac{f^2\xi}{fz^2} . \quad (\text{A3.2})$$

Substituting into Eq. (10) we obtain:

$$\begin{aligned} \frac{f^2E_z}{fr^2} + \frac{1}{r} \frac{fE_z}{fr} + \frac{f^2E_z}{fz^2} + \Lambda^2 E_z &= 0 \\ \frac{f^2E_r}{fr^2} + \frac{1}{r} \frac{fE_r}{fr} + \frac{f^2E_r}{fz^2} - \frac{E_r}{r^2} + \Lambda^2 E_r &= 0 . \end{aligned} \quad (\text{A3.3})$$

Using the technique of the separation of the variables we set:

$$E_z = F(r) \cdot \varphi(z) ; E_r = \Psi(r) \cdot f(z)$$

where F, φ, Ψ, f are functions only of the indicated variables. Substituting into (A3.3) we obtain:

$$F'' + \frac{1}{r} F' + (\Lambda^2 - k^2) F = 0 \quad (\text{A3.4})$$

$$\varphi'' + k^2 \varphi = 0 \quad (\text{A3.5})$$

$$\Psi'' + \frac{1}{r} \Psi' + (\Lambda^2 - k^2) \Psi = 0 \quad (\text{A3.6})$$

$$f'' + k^2 f = 0 \quad (\text{A3.7})$$

Equations (A3.4) and (A3.6) are the Bessel equation of zero and first order respectively while (A3.5) and (A3.7) are the familiar equation of the undamped harmonic motion.

Solving and putting for brevity $\alpha = \sqrt{\Lambda^2 - k^2}$ we obtain:

$$\begin{aligned} E_z &= [A_1 J_0(\alpha r) + A_2 N_0(\alpha r)] (A_3 \cos kz + A_4 \sin kz) \\ E_r &= [B_1 J_1(\alpha r) + B_2 N_1(\alpha r)] (B_3 \cos kz + B_4 \sin kz) \end{aligned}$$

where we have indicated with J and N respectively the Bessel and the Newman function. Because for $r = 0$ the Newman functions become infinite then it follows that A_2 and B_2 must be equal to zero. Moreover $n \times E = 0$ means that E_z should be zero for $r = r_0$ and that E_r should be zero for $z = 0$ and $z = h$. This means that we should have:

$$\alpha r_0 = \sqrt{\Lambda^2 - k^2} r_0 = P_{0\ell} ; \quad B_3 = 0 ; \quad k = \frac{m\pi}{h} \quad (\text{A3.8})$$

where $P_{0\ell}$ is the ℓ^{th} zero of the Bessel function of zero order. From (A3.8) the eigenvalue of Λ is determined and we have:

$$\Lambda_{0\ell m}^2 = \frac{P_{0\ell}^2}{r_0} + \frac{m\pi^2}{h^2} \quad (\text{A3.9})$$

The introduction of the last condition: $\nabla \cdot E = 0$ imposes two more constrains: $A_4 = 0$ (otherwise the sum of the derivatives can never be zero) and the condition on the coefficients $B_1 \frac{P_{0\ell}}{r_0} - A_1 \frac{m\pi}{h} = 0$. The problem is then solved.

APPENDIX 4

LOSSES IN TRANSMISSION LINES

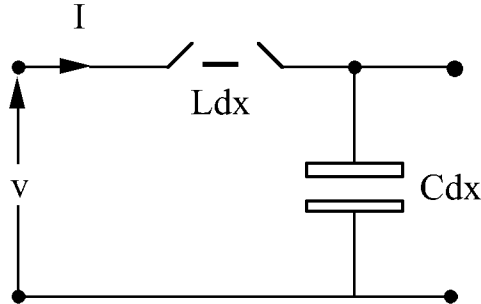

Inductance L and the capacitance, per unit of length, are defined on the basis of the energies stored by the fields. We write the Kirchoff laws for the infinitesimal quadrupole shown in the figure:

$$V - V + \frac{\delta V}{\delta x} dx = L dx \frac{dI}{dt} ; \quad I - I + \frac{\delta I}{\delta x} dx = C dx \frac{dV}{dt} .$$

Assuming the sinusoidal steady state and simplifying:

$$-\frac{dV}{dx} = j\omega LI ; \quad -\frac{dI}{dx} = j\omega C V .$$

Integrating and putting $\gamma = \sqrt{LC}$; $Z_0 = \sqrt{\frac{L}{C}}$ for clarity, we obtain the fundamental relations:

$$V(x) = A_1 e^{-j\gamma x} + A_2 e^{+j\gamma x} ; \quad Z_0 I(x) = A_1 e^{-j\gamma x} - A_2 e^{+j\gamma x}$$

where A_1 and A_2 are integration constants which depend upon the boundary conditions.

Assume that the lines are terminated at the origin, $x = 0$, on the load Z_L . Then we have: $A_1 + A_2 = V_L$; $Z_0 I_L = A_1 - A_2$ and it follows that:

$$A_1 = (Z_L + Z_0 I_L) / 2 ; \quad A_2 = (Z_L - Z_0 I_L) / 2 .$$

Substituting:

$$V(x) = V_L \cos \gamma x - j Z_0 I_L \sin \gamma x ; \quad I(x) = -j \frac{V_L}{Z_0} \sin \gamma x + I_L \cos \gamma x$$

It is common procedure to call $\ell = -x$, the distance from the origin, and so we obtain the canonical form.

$$V(x) = V_L \cos \gamma \ell + j Z_0 I_L \sin \gamma \ell$$

$$I(x) = j \frac{V_L}{Z_0} \sin \gamma \ell + I_L \cos \gamma \ell$$

APPENDIX 5

RESONANCE MODES OF THE ALVAREZ CAVITY

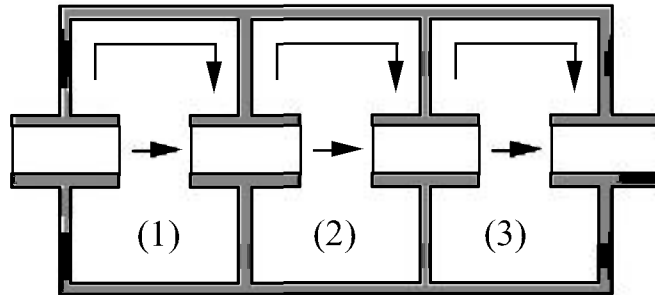

- a. In the three cavities the gaps are supposed to have the E fields equal and in phase. This means that the two internal walls do not carry any current.

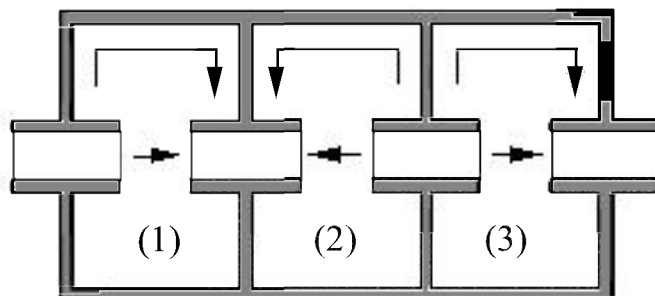

- b. In the three cavities the gaps are supposed to have the E fields with equal amplitude but opposed phases (the π mode). This means that the internal walls must carry current.

APPENDIX 6

WAVEGUIDES

In addition to transmission lines, another way of transmitting electromagnetic power is by means of waveguides. Uniform waveguides are metallic tubes with constant cross-section and straight axis and, in practice, they always have rectangular or circular cross-sections. Moreover we limit ourselves here to the case of the lossless waveguides.

Let us indicate with T the coordinates of the cross-section (x, y and r, ϕ for the two cases). If $\psi(T)$ indicates any real function of the transverse coordinates then:

$$\begin{matrix} E \\ H \end{matrix} \propto \psi(T) e^{j(\omega t - \beta z)} \quad (\text{A6.1})$$

indicates a sinusoidal field which propagates along the z axis with phase velocity v_p equal to ω/β where β is a real function of ω that for the moment is unknown (here, in order to be consistent with the current engineering literature, the quantity β is the propagation constant and should not be confused with the normalized speed of the particles).

If the above fields are substituted into the Maxwell equations we obtain a linear system where the transverse fields depend upon the derivatives of the longitudinal fields. Solving the system we obtain:

Rectangular coordinates	Cylindrical coordinates
$E_\phi = \frac{j}{k_c^2} \frac{\partial}{\partial r} \left(-\beta \frac{\partial E_z}{\partial \phi} \right) + \omega \mu \frac{\partial H_z}{\partial r}$	$E_r = \frac{-j}{k_c^2} \frac{\partial}{\partial r} \left(\beta \frac{\partial E_z}{\partial r} \right) + \frac{\omega \mu}{r} \frac{\partial H_z}{\partial \phi}$
$E_y = \frac{j}{k_c^2} \frac{\partial}{\partial x} \left(-\beta \frac{\partial E_z}{\partial y} \right) + \omega \mu \frac{\partial H_z}{\partial x}$	$E_\phi = \frac{j}{k_c^2} \frac{\partial}{\partial r} \left(-\beta \frac{\partial E_z}{\partial \phi} \right) + \omega \mu \frac{\partial H_z}{\partial r}$
$H_x = \frac{j}{k_c^2} \frac{\partial}{\partial x} \left(\omega \epsilon \frac{\partial E_z}{\partial y} \right) - \beta \frac{\partial H_z}{\partial x}$	$H_r = \frac{j}{k_c^2} \frac{\partial}{\partial r} \left(\omega \epsilon \frac{\partial E_z}{\partial r} \right) - \beta \frac{\partial H_z}{\partial r}$
$H_y = \frac{-j}{k_c^2} \frac{\partial}{\partial x} \left(\omega \epsilon \frac{\partial E_z}{\partial x} \right) + \beta \frac{\partial H_z}{\partial y}$	$H_\phi = \frac{-j}{k_c^2} \frac{\partial}{\partial r} \left(\omega \epsilon \frac{\partial E_z}{\partial \phi} \right) + \frac{\beta}{r} \frac{\partial H_z}{\partial \phi}$

(A6.2)

where

$$k_c^2 = \omega^2 \epsilon \mu - \beta^2 .$$

From the above equations, we obtain:

$$E_T = -\frac{j\beta}{k_c^2} \nabla_T E_z ; \quad H_T = -\frac{j\beta}{k_c^2} \nabla_T H_z \quad (\text{A6.3})$$

where with ∇_T we indicate the gradient operator in the transverse plane.

It is now evident that our problem is solved when we know the longitudinal components E_z and H_z and the value of k_c . Before proceeding with this determination we recognize that:

- i) The solutions E_z and H_z are obviously independent. From the systems (A6.2) we see that the total field in the guide may depend upon both the E_z and H_z functions.

- ii) The fields for which $H_z \neq 0$ are called transverse magnetic (TM) modes (accelerating modes), while the fields for which $E_z \neq 0$ are the transverse electric (TE), deflecting, modes.

The scalar potentials E_z, H_z together with the corresponding values of k_c , are obtained as follows. We indicate with \mathbf{V} a vector which can represent either E or H and from the Maxwell equations we obtain the familiar vector wave equation:

$$\nabla^2 \mathbf{V} = +\varepsilon\mu \frac{f^2}{f_0^2} \mathbf{V} .$$

For the z component we obtain (in both the coordinate systems):

$$\nabla_T^2 V_z + \frac{f^2 V_z}{f_z^2} = +\varepsilon\mu \frac{f^2 V_z}{f_0^2}$$

where ∇_T^2 indicates the scalar bidimensional (transverse) Laplacian operator. Introducing the general hypothesis (A6.1) we obtain the fundamental equation:

$$\nabla_T^2 V_z + (\omega^2 \varepsilon\mu - \beta^2) V_z = 0$$

or

$$\nabla_T^2 \frac{E_z}{H_z} + k_c^2 \frac{E_z}{H_z} = 0 . \quad (\text{A6.4})$$

We know that given the appropriate boundary conditions this equation can be solved for an infinite number of discrete real values of k_c (the eigenvalues) to which correspond an infinite number of eigenfunctions.

With reference to the cross-sections and reference systems for rectangular and circular waveguides, shown below we obtain:

Cartesian	Cylindrical
$E_z = E_0 \sin \frac{m\pi}{a} x \sin \frac{n\pi}{b} y$	$E_z = E_0 J_\nu(k_c r) \begin{matrix} \cos \nu\phi \\ \sin \nu\phi \end{matrix}$
$H_z = H_0 \cos \frac{m\pi}{a} x \cos \frac{n\pi}{b} y$	$H_z = E_0 J_\nu(k_c r) \begin{matrix} \cos \nu\phi \\ \sin \nu\phi \end{matrix}$
$k_c^2 = \frac{m\pi}{a}^2 + \frac{n\pi}{b}^2$	$k_c = \begin{matrix} \frac{P_{\nu l}}{a} & \text{for } E_z \\ \frac{P'_{\nu l}}{a} & \text{for } H_z \end{matrix}$

(A6.6)

where m, n and ν, l are couples of arbitrary integers, J_ν is the Bessel function of order ν , $P_{\nu l}$ and $P'_{\nu l}$ are respectively the l^{th} root of the Bessel function of order ν and the l^{th} root of its derivative.

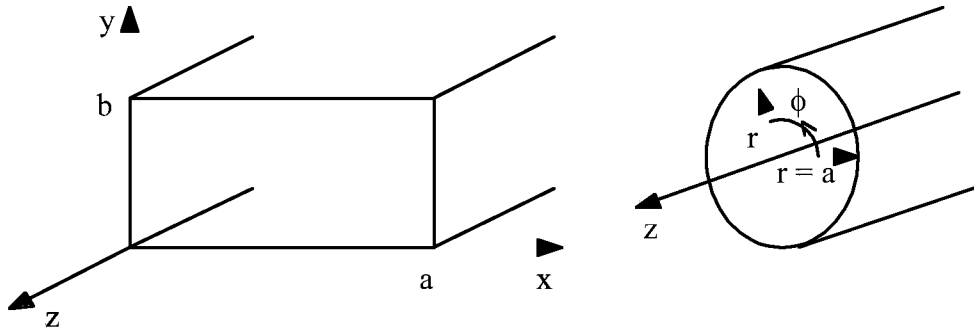

From Eqs. (A6.5) and (A6.6) we know the possible form for the longitudinal fields and the corresponding values of the eigenvalues k_c . Recalling that k_c is related to the phase constant β we obtain:

$$\beta = \frac{2\pi}{\lambda_g} = \sqrt{\omega^2 \epsilon \mu - k_c^2} . \quad (\text{A6.7})$$

It is now clear that because k_c is always real then the propagation in a waveguide is always possible (i.d. β is real) above certain "cut-off" frequencies which depend upon the chosen mode of propagation (choice between TE or TM modes and choice of the integers m, n or v, l according to the cross-section of the guide). Moreover since $\omega^2 \epsilon \mu$ must be larger than k_c^2 then λ_g must be larger than λ . Consequently, phase velocity v_p must be larger than $1/\sqrt{\epsilon \mu}$.

APPENDIX 7

THE LOADED QUALITY FACTOR Q_L

The normal definition:

$$Q = 2\pi \frac{\text{Energy spread}}{\text{Energy lost per cycle}}$$

is used under the assumption that the cavity is not coupled to any circuit.

If the cavity is coupled to an external circuit (normally the generator), then the output-impedance of this circuit (normally real) affects all the coupled modes and the quality factor of each mode changes. These new quality factors are the loaded Q denoted as Q_L .

Consider the two examples a) and b) below.

a)

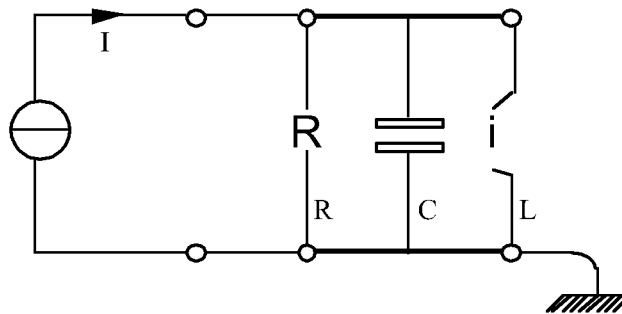

$$\omega_0^2 = 1/LC$$

$$Q = \omega_0 RC$$

$$|Z| = \frac{R}{1 + jQ \left(\frac{F}{F_0} - \frac{F_0}{F} \right)}$$

Since the output impedance of the ideal current generator is supposed to be infinite, then the quality factor that we can measure from the band-width of the modulus of the impedance is the normal (or unperturbed) one.

b)

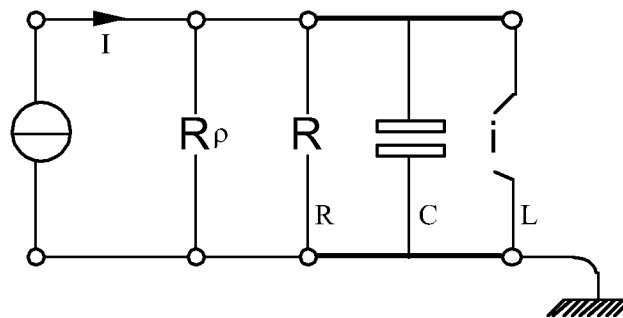

$$R_p = \frac{R\rho}{R + \rho} < R$$

$$\omega_0^2 = 1/LC ; \quad Q_p = \omega_0 R_p C$$

$$|Z| = \frac{R_p}{1 + jQ_p \left(\frac{F}{F_0} - \frac{F_0}{F} \right)}$$

In this case we assumed that the output impedance of the generator is ρ and because $Q_p < Q$, then the band-width of the circuit is increased. Using the normal way of naming the parameters with special names we replace Q_p with Q_L .

Coming back to the cavities: the stronger is the coupling, the lower is the loaded Q . In other words: the stronger the coupling the larger the band-width. For instance when the coupling to the generator is adjusted for maximum energy transfer, then the loaded Q_L is one half of the unperturbed one. Sometimes (not always!) the power given to the beam is considered but this confused situation should be avoided if at all possible.