

**INSTITUTE FOR NUCLEAR STUDY
UNIVERSITY OF TOKYO
Tanashi, Tokyo 188
Japan**

INS-Rep. -1088
Jan. 1995

INS--1088
JP9503014

High resolution and two-dimensional focal plane detector for intermediate energy heavy ions

**M. H. Tanaka ^{a,*}, Y. Fuchi ^a, S. Kubono ^a, T. Ichihara ^b,
H. Kawashima ^a, S. Takaku ^a**

^a Institute for Nuclear Study, University of Tokyo, Midori-cho 3-2-1, Tanashi, Tokyo,
188 Japan

^b The Institute of Physical and Chemical Research, Hirosawa 2-1, Wako, Satitama,
350-01 Japan

High resolution and two-dimensional focal plane detector for intermediate energy heavy ions

M. H. Tanaka ^{a,*}, Y. Fuchi ^a, S. Kubono ^a, T. Ichihara ^b,
H. Kawashima ^a, S. Takaku ^a

^a Institute for Nuclear Study, University of Tokyo, Midori-cho 3-2-1, Tanashi, Tokyo,
188 Japan

^b The Institute of Physical and Chemical Research, Hirosawa 2-1, Wako, Satitama,
350-01 Japan

Abstract

A large-area, high-resolution two-dimensional position sensitive gas detector has been developed for intermediate energy heavy ions. The x position information is obtained by a multi-cathode read-out method and the y position by measuring the drift time of electrons. This detector has no left-right ambiguity and very little dead layer in the sensitive area, resulting in a detector system which is thin and homogeneous in the whole sensitive area. The overall position resolution of 0.20 mm and 0.4 mm (FWHM) were obtained for x and y directions, respectively. The position resolutions at lower gas pressure were also measured to find an optimum operating condition to reduce multiple scattering effect from the window foils and the detector gas. This detector has been shown to be very useful for high-resolution heavy ion experiments at intermediate energies.

1. Introduction

As a two-dimensional position detector for a magnetic spectrograph, large active area Multi-Wire Drift Chambers (MWDC) have been widely used with high position resolution and high count rate. However, it has a left-right ambiguity and also needs a

* Corresponding author. Tel. +81-424-69-9571, Fax. +81-424-68-5844, E-mail tanaka@insuty.ins.u-tokyo.ac.jp.

large number of read-out elements. To solve this ambiguity, three layers of MWDCs are usually used. This fact together with many dead areas of many wires and window foils prevents a high position resolution measurement for intermediate energy heavy ions. On the contrary, Single Wire Proportional Counter (SWPC) has no left-right ambiguity and has a very simple structure. However, it usually does not have a large active area and the position resolution depends on the length of the detector. And the count rate of a charge division method for SWPCs is not high, since a resistive wire is used for the sense wire. The resolution by the charge division method for SWPCs is ordinary about 1/1000 of the length of the sense wire. For instance, if the length of the sense wire is longer than 50 cm, the position resolution should be worse than 0.5 mm.

A new method for read-out which uses multi-cathodes has been reported [1,2]. This read-out method is known to give a high position resolution irrelevant to the wire length and high count rate. Therefore, this method will improve the position resolution and the count rate problem for SWPCs. On the other hand, a good y position resolution (<0.5 mm) has been obtained by measuring a drift time of secondary electrons for a drift space of 35 mm with a focal plane detector [3] for the QDD spectrograph [4] at the Institute for Nuclear Study, University of Tokyo (INS). This is a kind of single drift chamber of a drift length of 35 mm in y direction, and 80 cm long SWPC in x direction. Thus, we simply extended the drift space to 10 cm as requested for the design, requiring about 3 kV for the drift space. The diffusion effect of the secondary electrons during the 10 cm drift for the position resolution for both x and y is estimated to be 0.3 mm at an atmospheric pressure (atm) [5,6]. This position resolutions certainly meet the requested values of less than 0.5 mm.

This is a report of a development of a detector system which has a high count rate, very little dead area in the counting space and no left-right ambiguity for intermediate-energy heavy ion experiments at the Institute of Physical and Chemical Research (RIKEN). This detector was designed as a focal plane detector of a high resolution magnetic spectrograph, the SMART (a Swinger and a Magnetic Analyzer with Rotator and Twisters) [7] for intermediate-energy heavy ions from the RIKEN Ring Cyclotron

(RRC) with $K = 540$. The requirements for the detector are as follows: The sensitive area is 50 cm in the x direction (the momentum dispersion direction) and 10 cm in the y direction (the angular direction). The position resolutions should be better than 0.5 mm full width at half maximum (FWHM) in both x and y directions. The maximum count rate should be no less than 10^4 counts per second (cps). The particle identification should be made completely up to Ne isotopes, while rejecting multi-hit events.

The optimum condition was also investigated to reduce the multiple scattering effect and δ -ray effect from the foils and the gas of the detector, which worsen the final resolution in the practical operations.

Part of this work has been already published elsewhere [8].

2. Detector Design

Figure 1 shows a schematic view of the multi-cathode read-out single-wire drift counter (CRDC) designed here. The effective detecting area has a drift space of 100 mm long in the drift direction (y direction) and a length of 500 mm in the x direction for the secondary electrons which are produced by incident particles, and the thickness of the counter is 15 mm. To realize a uniform electric field in the drift space, field wires of a diameter of 50 μm are used at an interval of 10 mm, giving very little dead layer in the sensitive area. These field wires will be removed in the next design to achieve no dead layer using guard plates outside the chamber as was made for the INS detector [3]. A proportional chamber is placed on the top of the drift space. The proportional chamber is separated from the drift space with grid wires of 50 μm of 2 mm spaces. The cross section of the proportional chamber is a square of a side of 15 mm. The anode wire, a gold plated tungsten wire of 55 cm long and a diameter of 12.5 μm , is set in the center of the chamber. Multi cathodes were set along the top side of the proportional chamber. Thus, the distance between the anode and the cathode is 7.5 mm. A high x position resolution should be obtained by a cathode which has roughly the same width as the distance between the anode wire and the cathodes [9]. Therefore, the cathode was divided into 64 strips whose width is 7.5 mm with 0.5 mm separation between them.

We estimated the position resolution with this geometry to be 0.09 mm assuming 0.2 % of the electric noise [9]. We expected less noise level than 0.2 % by introducing the preamplifiers inside the detector box. It is also easy to handle the proportional chamber of 15 mm of cross section. Therefore, we have chosen this size of cross section for the proportional chamber. The strips are followed by charge-sensitive pre-amplifiers independently. Each ten pre-amplifiers are packed into a can and enclosed in the detector box in order to reduce the noise level.

On the other hand, the position in the y direction is determined by measuring the drift time of the secondary electrons, using the anode signal of the proportional counter and the signal of the plastic scintillators which are placed behind the CRDCs for the stop and start signals, respectively. A timing filter amplifier and a constant fraction discriminator are used to get a fast timing signal from the proportional counter. The two-layer plastic scintillators also give TOF information and also ΔE or E information. The anode signals of the gas counter also provide ΔE information which can be used for the particle identification.

The whole detector system consists of two CRDCs and two-layer plastic scintillators. They are all arranged in a series and perpendicularly to the beam direction in the vicinity of the second focal plane of SMART. The distance between the two CRDCs is 55 cm. Using two dimensional position information, ray tracing is performed. This two-scintillator system is effective to reduce background events for intermediate-energy heavy-ions.

3. Result and Discussion

The beam tests were performed with a faint proton beam of 30 MeV from the SF-cyclotron at INS, since this beam gives a smaller energy loss than the 135 MeV/A ^{12}C beam and thus the test would be more severe than the heavy ion case. The CRDC was operated while flowing a mixed gas of Ar 70% and CH_4 30%. This gas mixture was chosen to get rather long plateau of the voltage for the drift speed of electrons [5,6]. The x and y position resolutions were tested individually.

The position resolution of x direction was tested with a small size CRDC of 24 cm wide and 3.5 cm high, which fitted in the detector box of the QDD spectrograph [4]. To get a small beam spot, the QDD spectrograph was set at 0 degree without any target and the faint beam was directly transported into the focal plane where the CRDC was set. The detector gas pressure was 1 atm. The anode voltage was searched to be 1980 volts for the best resolution. The overall x position resolution obtained was 0.20 mm FWHM, as shown in fig. 2. Therefore, the intrinsic resolution of the detector should be equal or less than 0.20 mm FWHM.

The y position resolution was tested with the full-size CRDC by a double slit method. The CRDC was placed in the air behind the Kapton foil which was the end of the beam duct. Two slits (0.2 mm width) were placed just before and behind the CRDC. The voltage of 3000 volts for the drift space, the electric field strength of 0.40 volt/(cm-mmHg), was found to give the best resolution for the case of 1 atm and the drift velocity of the electrons was also found to be well saturated at this field strength. The position resolution in y direction was tested at the point of 15 mm and 85 mm from the grid. The overall y position resolutions obtained were 0.4 mm in FWHM at both points. The x position resolution with the full-size CRDC was also tested by the same way for the test of y position resolution. The results were 0.4 mm FWHM at both y-positions. These resolutions for both x and y positions are clearly limited by the double slit method which is suffered from an edge scattering problem at the slit and the multiple scattering effect of the window foils and the detector gas. The diffusion effect of the drifting electrons in the drift space was not visible through the present resolutions. We are also planning to clarify experimentally the intrinsic y-resolution with a short detector setting the y-direction of the detector horizontally on the QDD focal plane where one can get a small size of beam.

From the present experimental results, the CRDC designed here has been proved to satisfy the requirements for the position resolutions at 1 atm. In our detector arrangement, however, the second detector is set 55 cm behind the first detector. Therefore, the beam spread problem by multiple scattering from the window foils and the gas of the first

detector became serious. This effect was estimated to be about 0.8 mm FWHM at the second detector with Kapton Polyimide foil of 75 μm thick and 1 atm Ar 70% + CH₄ 30% of 5 cm thick for the beam of ¹²C, 135MeV/A. To reduce this effect we needed to use thinner foils and lower gas pressures. However, the position resolution of the drift counter usually becomes worse when the counter is operated at lower gas pressure, since the diffusion effect during the drift becomes larger. Therefore, we also have tested the position resolutions of the detector at low pressures.

A gas-pressure and drift-length dependence of the position resolution in y direction was tested with a single wire drift chamber (SWDC) which has the same effective area, 10 x 50 cm², since the CRDC with 10 cm drift space does not fit to the focal plane box of the QDD spectrograph. Two slits (0.2 mm width) were placed just before and behind the SWDC. The gas pressure was changed from 1 to 0.5 atm. The drift length was also changed from 15 to 85 mm from the grid at each pressure. The voltages applied to the drift plate, which gave the best resolution and the saturated drift velocity at each pressure, were found to be the same, 0.40 in the unit of volt/(cm·mmHg). The applied voltages to the anode were also searched for the best resolution at each pressure. Figure 3 shows the drift length dependence of the y position resolution at each gas pressure denoted. The position resolution changes little as a function of y at 1 atm as mentioned before. The dependence at 0.75 atm is visible already in the figure. The dependence becomes larger as the pressure becomes low. The lines in the figure are to guide the eye.

As can be seen in the figure, the resolutions at the pressure of 0.75 atm are acceptable for the present application. We can use 25 μm Kapton foil at this pressure, reducing the multiple scattering effect from 0.8 mm to 0.5 mm. Therefore, our final detector arrangement is as follows: The first detector has the window of 25 μm thick Kapton foil and the gas pressure of 0.75 atm, and the second has the window of 75 μm Kapton foil and the gas pressure of 1 atm being 55 cm behind the first detector. In addition a SWPC was placed to reduce erroneous trajectory construction due to δ -rays.

The CRDCs have been used for heavy-ion reaction studies at intermediate energies at RIKEN. Figure 4 shows typical momentum spectra of ^{12}N from the $^{12}\text{N}(^{12}\text{C}, ^{12}\text{N})^{12}\text{B}$ reaction at $E/u = 135$ MeV[10]. The particle identification was easily made by using ΔE signals from the gas proportional counter and the TOF generated from the plastic counter and the RF signal of the cyclotron. The upper one is the spectrum of an angular bin of $0^\circ - 0.2^\circ$ and the lower one is of $1.0^\circ - 1.2^\circ$. The overall energy resolution obtained was about 700 keV FWHM. This energy resolution corresponds to 1.3 mm of spatial resolution which is composed of the counter resolution, the multiple scattering effect and the others (the beam energy spread, the δ -ray effect, etc.). They are roughly estimated to be about 0.4, 0.7 and 1 mm, respectively. We are planning to improve the resolution in near future by a better transport condition and dispersion matching to reduce the beam energy spread.

There is a problem caused by δ -rays from the detector foils and gas, which worsens the timing and position resolutions. The wrong position information caused by the δ -rays was partially discriminated by an additional information using a third detector which was placed just behind the second CRDC. This δ -ray effect alone is not determined yet, although we estimated the effect is about 1 mm FWHM which includes the incident beam spread as well. This problem has to be solved in the near future.

The maximum count rate of the CRDC is not fully tested yet. The spectra in fig. 4 were obtained with a count rate of about two thousand cps. We also obtained some spectra with a count rate of $3\sim 4 \times 10^3$ cps with the same resolution.

To get accurate position information for the correct energy information, there is a problem of non linearity[2, 9] in the position evaluation from the multistrips depending on the choice of algorithm. Although we used simply the center of gravity method for the moment, we will introduce a correction method of the empirical transformation in the near future.

4. Summary

A two-dimensional position detector has been developed as a detector system of the second focal plane of SMART for the research of intermediate-energy heavy ion reactions at RIKEN. A thin and homogeneous detection area and high resolution have been achieved by the CRDC which has a structure of a combination of a single drift space and multi cathodes for read out.

The CRDCs were tested with the faint proton beams of 30 MeV. The best resolutions obtained were 0.20 and 0.4 mm FWHM including the beam size at 1 atm for x direction and y direction, respectively, although the Δy is not fully tested, which should be tested. The operational condition with lower gas pressure was also searched to reduce the multiple scattering effect. The drift length and gas pressure dependence of position resolution was also tested using double slit method. The resolutions at the pressure of 0.75 atm were acceptable for the requirements. There are some problems that have to be solved and modifications to be made in the near future, including the δ -ray effect, a correction method for the evaluation of position. The present detector system has been used for heavy-ion reaction studies at intermediate energies with SMART at the RIKEN successfully.

The authors are indebted to Professor. H. Okuno for helpful discussions and also Professors. T. Nomura and I. Katayama for the support.

References

- [1] A. Breskin, G. Charpak, C. Demierre, S. Majewski, A. Policarpo, F. Sauli and J. C. Santiard, *Nucl. Instr. and Meth.* 143 (1977) 29.
- [2] I. Endo, T. Kawamoto, Y. Mizuno, T. Ohsugi, T. Taniguchi and T. Takeshita, *Nucl. Instr. and Meth.* 188 (1981) 51.
- [3] M. H. Tanaka, S. Kubono, S. Kato, *Nucl. Instr. and Meth.* 195 (1982) 509.
- [4] S. Kato, T. Hasegawa and M. Tanaka, *Nucl. Instr. and Meth.* 154 (1978) 19.
- [5] D. Schmit, *Nucl. Instr. and Meth.* 176 (1980) 39.
- [6] W. Sauli, CERN 77-09.
- [7] H. Ohnuma et al., *Proc. Second IN2P3-RIKEN Symp. on Heavy-Ion Collisions*, eds. B. Heusch and M. Ishihara (World Scientific, Singapore, 1990) p. 26.
- [8] Y. Fuchi, M. H. Tanaka, S. Kubono, H. Kawashima, S. Takaku and T. Ichihara, *Conf. Rec. of the IEEE Nuclear Science Symposium and Medical Imaging Conference, Orlando, Oct. 25-31, 1992, Vol. 1*, 172-174.
- [9] J. Chiba, H. Iwasaki, T. Kageyama, S. Kuribayashi, K. Nakamura, T. Sumiyoshi and T. Takeda, *Nucl. Instr. and Meth.* 206 (1983) 451.
- [10] T. Ichihara, T. Niizeki, H. Okamura, H. Ohnuma, H. Sakai, Y. Fuchi, K. Hatanaka, M. Hosaka, S. Ishida, K. Kato, S. Kato, H. Kawashima, S. Kubono, S. Miyamoto, H. Orihara, N. Sakamoto, S. Takaku, Y. Tajima, M. H. Tanaka, H. Toyokawa, T. Yamamoto, M. Yosoi and M. Ishihara, *Nucl. Phys.* A569 (1994) 287.

Figure captions

- Figure 1 A schematic view of the multi-cathode read-out single-wire drift counter (CRDC). The unit of length in the figure is mm. Each number stands for ① pre-amplifier, ② multi-cathodestrips, ③ anode-wire, ④ gird, ⑤ field wires, ⑥ window foil and ⑦ drift plate.
- Figure 2. A typical x position spectrum for the proton beam of 30 MeV, obtained by the small-size CRDC. The distance between the two peaks is 5.70 cm.
- Figure 3. The gas pressure and drift length dependence of the y position resolution. The error bar is within the dot size.
- Figure 4. Typical momentum spectra of ^{12}N from the $^{12}\text{N}(^{12}\text{C}, ^{12}\text{N})^{12}\text{B}$ reaction at $E/u = 135$ MeV. The upper one is the spectrum of an angular bin of $0^\circ - 0.2^\circ$ and the lower one is of $1.0^\circ - 1.2^\circ$.

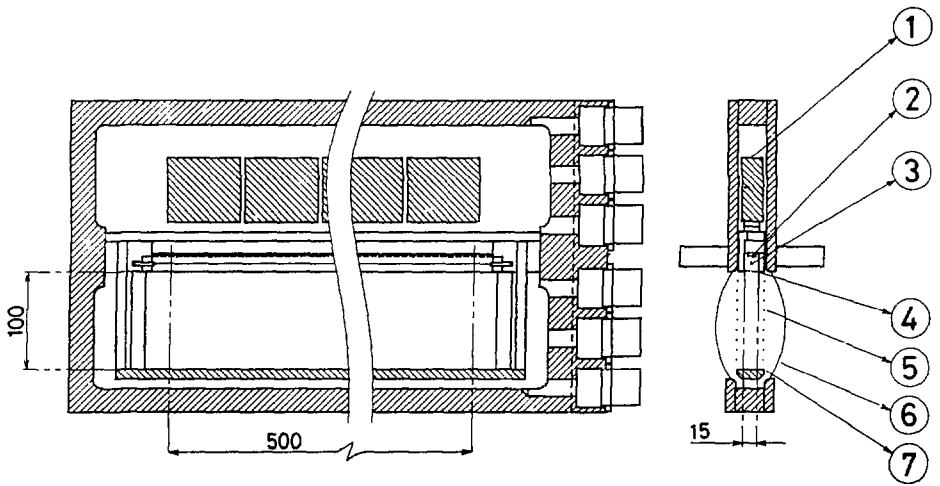

Fig. 1

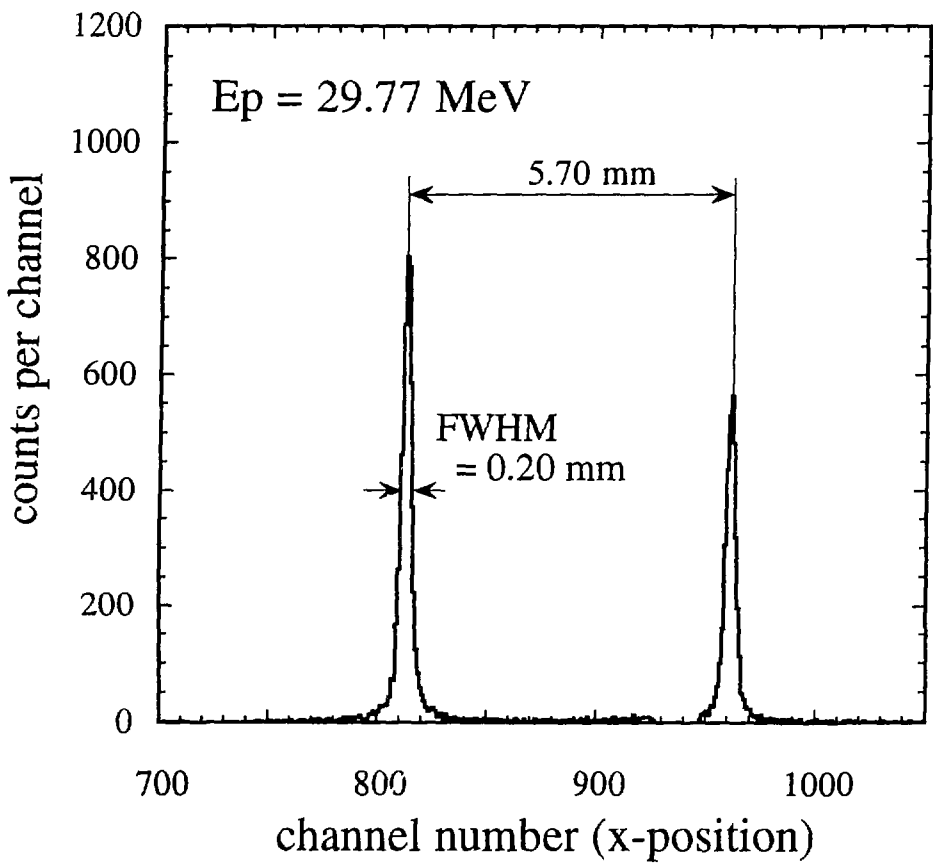

Fig. 2

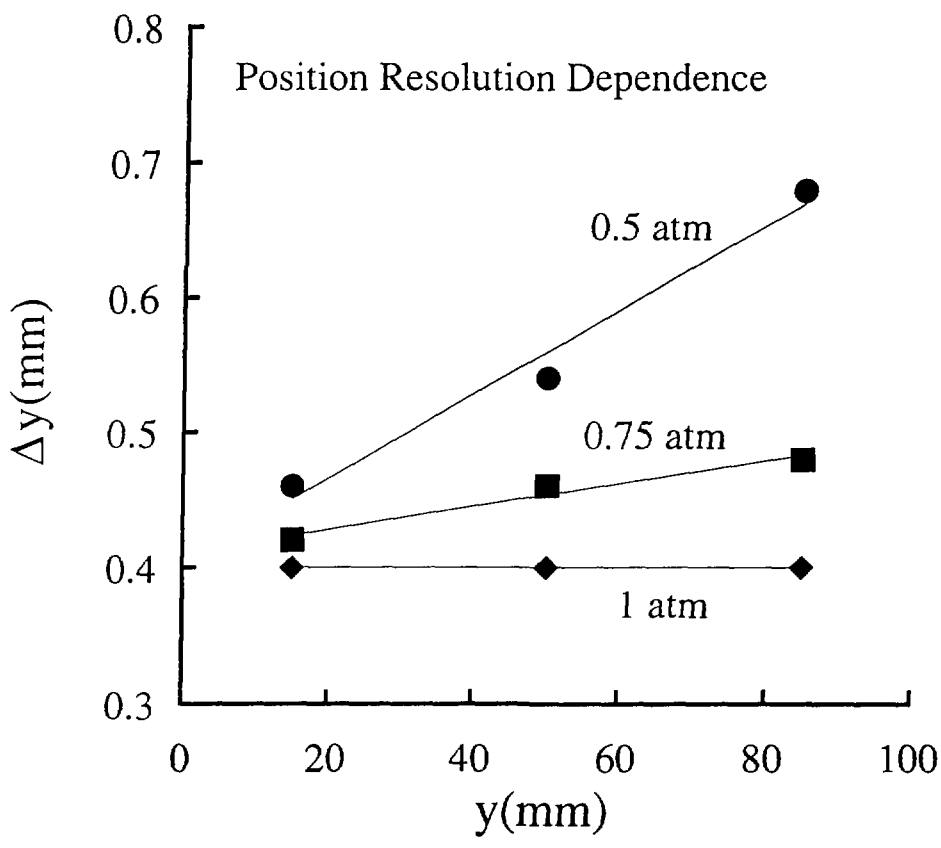

Fig. 3

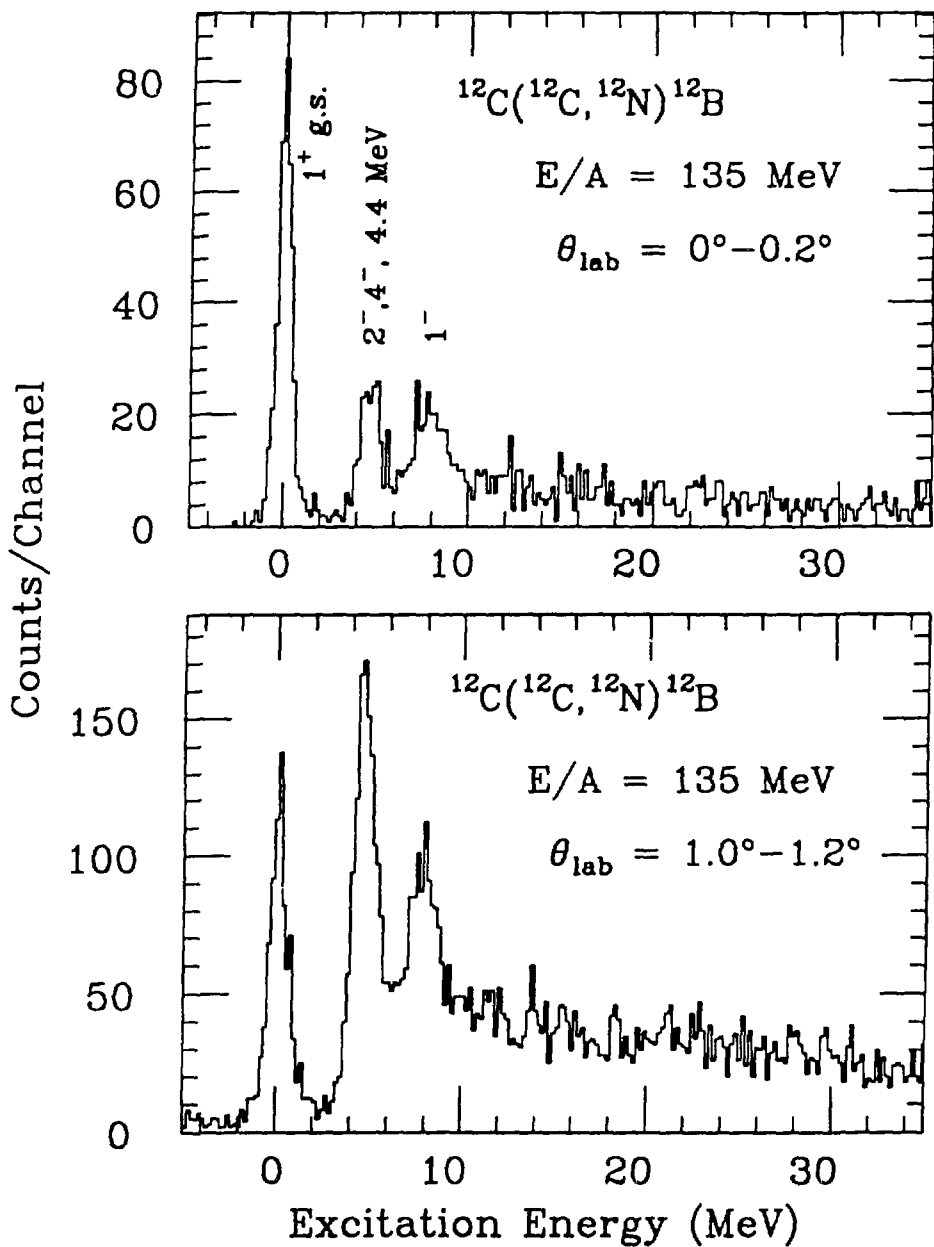

Fig. 4