

SIMULATION OF PEP-II BEAM POSITION MONITORS*

C.-K. Ng, T. Weiland[†], D. Martin, S. Smith and N. Kurita
Stanford Linear Accelerator Center, Stanford University, Stanford, CA 94309

Abstract

We use MAFIA to analyze the PEP-II button-type beam position monitors (BPMs). Employing proper termination of the BPM into a coaxial cable, the output signal at the BPM can be determined. Thus the issues of sensitivity and power output can be addressed quantitatively, including all transient effects and wakefields. Besides this first quantitative analysis of a true BPM 3D structure, we find that internal resonant modes are a major source of high value narrow-band impedances. These are evaluated and methods are presented to suppress these parasitic resonances below the tolerable limit of multibunch instabilities.

I. INTRODUCTION

There are several issues of concern for the button-type BPMs in the PEP-II [1] vacuum chamber. First, the presence of BPMs in the vacuum chamber contributes significant impedances, broad-band and narrow-band. For broad-band impedance, the contribution of all the BPMs to the total impedance budget can be readily calculated. Narrow-band impedances arise from the formation of resonances or trapped modes in the BPM, which may have detrimental effects on the beams because of coupled-bunch instabilities, and which may produce heating effects above tolerable levels. Second, the power coming out of the cable connected to the BPM should not be too high such that it is within the handling capability of the diagnostic electronics, but not at the expense of losing the signal sensitivity at the frequency of interest which is 1 GHz. Third, the power carried by the trapped modes and by the signal, especially when the beam is offset, may produce considerable heating in the ceramic and metallic walls of the BPM. These issues are closely related to each other, thus increasing the complexity of designing the BPM. In view of these electrical and mechanical requirements, 1.5-cm diameter buttons have been selected for PEP-II BPMs.

II. MAFIA MODELING

The detailed layout of the BPM in the arcs of the PEP-II ring is shown in Fig. 1. Each BPM consists of four buttons, located symmetrically at the top and at the bottom of the vacuum chamber. Each of the High Energy Ring (HER) and Low Energy Ring (LER) contains approximately 198 BPMs in the arcs [1]. There are 92 BPMs in the straight sections of each ring, and the four buttons are located symmetrically at 90° from each other at the circumference of the circular pipe. The BPM button is tapered in such a way that the impedance matches that of a

50 Ω coaxial line. A ceramic ring for vacuum insulation is located near the button region. It has a dielectric constant of about 9.5. The inner radius of the ceramic ring needs to be adjusted for optimum matching.

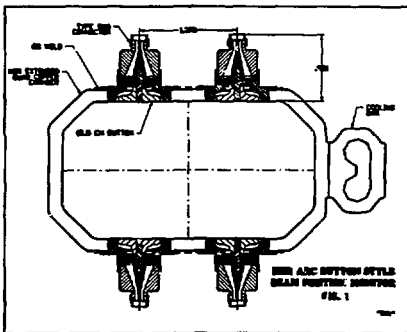

Figure 1 Layout of the 4 buttons of a BPM in the arcs of the HER vacuum chamber.

The 3D MAFIA model of the BPM is shown in Fig. 2. Because of symmetry, only one quarter of the structure is simulated. One button of the BPM is situated on the top of the vacuum chamber, and it tapers gradually to a coaxial line above. The simulation is done in the time domain, which consists of two kinds of calculations, namely wakefield and port transmission calculations. For wakefield calculation, a rigid beam comes in along the x -direction. It excites electromagnetic fields at the BPM, which in turn act back on the beam. The boundary conditions at the beam entrance and exit planes are set to waveguide boundary conditions so that electromagnetic waves traveling to these boundaries are not reflected. At the top boundary of the coaxial line, it is treated as an outgoing waveguide port, where the transmission of the signal is determined. A two-dimensional eigenvalue problem is first solved to determine the propagating and evanescent modes of the coaxial line. These modes are then loaded at the port in the 3D time domain calculation. Since the beam excites a broad frequency spectrum, a broad-band boundary has to be implemented at the waveguide port.

The impedance of a BPM can be evaluated from the wakefield or its Fourier transform. From the Fourier transform of the wakefield, we can identify potential resonant modes excited in the BPM by the bunch. Since the resolution of narrow resonances in the impedance spectrum depends on the number of sampling points in the wakefield calculation, we calculate the wakefield up to a large dis-

*Work supported by the Department of Energy, contract DE-AC03-76SF00515.

[†]Permanent address: University of Technology, FB18, Schlossgartenstr.8, D64289, Darmstadt, Germany.

tance of $s = 5$ m, where s is the bunch coordinate. The transmission calculation at the port gives us the value of the outgoing voltage at the end of the coaxial line as a function of time, which corresponds to the signal picked up by the BPM as the beam passes through this region of the vacuum chamber.

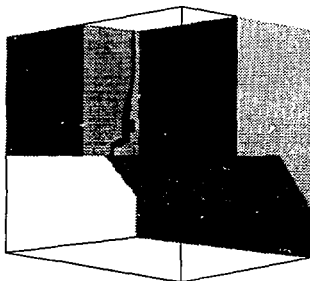

Figure 2. 1/4 MAFIA geometry of the BPM in the vacuum chamber. The button region is cut out for viewing purposes.

III. SIMULATION RESULTS

The high beam current in the PEP-II B-Factor poses stringent requirements on impedances and power deposition. BPMs can generate considerable broad-band and narrow-band impedances. To avoid single-bunch instabilities, the accepted limit of the total broad-band effective impedance for the prescribed PEP-II current is $|Z/n|_{eff} = 0.5 \Omega$ [1], where $n = \omega/\omega_{res}$ is the harmonic number. It is desirable that BPMs contribute a small fraction to the total broad-band impedance budget. Narrow-band impedances can also be generated as a result of the excitation of trapped modes in the BPMs. Their values have to be controlled below some limits so that coupled-bunch instabilities will not occur. The most serious higher-order mode excited by the beam is the TE_{11} mode with respect to the button axis. Its frequency increases with the decrease in the diameter of the button. The acceptable limit of the narrow-band impedance for avoiding coupled-bunch instabilities is a function of the frequency $f = \omega/2\pi$ of the resonant mode and is given by [2]:

$$\left(\frac{Re[Z]}{k\Omega}\right) < 3.0 \left(\frac{GHz}{f}\right) e^{(\omega\sigma_z/c)^2}, \quad (1)$$

where σ_z is the bunch length which is taken to be 1 cm. It should be noted that the above limit is a conservative estimate since it takes into account of only radiation damping. Other damping mechanisms such as feedback will help suppress the narrow-band resonance. The numerical factor is given for the LER with a current of 3 A, and the limit is inversely proportional to the current. The exponential factor indicates the decay of the beam spectrum at high frequencies.

In the following, we present the numerical results from MAFIA simulations. In our simulations, a Gaussian bunch with $\sigma_z = 1$ cm is used and the total bunch length is $10\sigma_z$. For the coaxial port, at the range of frequency of interest, only the TEM mode propagates. Thus for the output signal at the coaxial line, we only need to consider this mode at the port. The MAFIA results shown in the following figures are normalized to a bunch charge of 1 pC. The numerical results for impedance, power and other relevant quantities for the case with 3 A current (8.3×10^{10} per bunch) are listed in Table 1.

Energy loss by beam	126 W
Power out of one cable	9 W (37 W)*
Transfer impedance at 1 GHz	0.65 Ω
Broad-band impedance, $ Z/n $	0.008 Ω (11 nH)
Narrow-band impedance:	MAFIA accepted
	6.5 k Ω at ~ 6.8 GHz
	3.4 k Ω

Table 1: Impedance and power of the 1.5-cm BPM. The beam current is 3 A. The impedances are for all the BPMs in the ring. *The power in the parentheses is that out of the cable which is closest to the beam when it is 1 cm offset from the axis.

(a) Impedances

In Fig. 3, we show the longitudinal wakefield as a function of the beam coordinate s . It can be seen that, for $0 \leq s \leq 10\sigma$, the wakefield is inductive in nature. The inductance of each BPM is estimated to be 0.04 nH or $|Z/n| = 3.4 \times 10^{-2} \Omega$. The total contribution of all the BPMs is 11 nH or $|Z/n| = 0.008 \Omega$. The total broad-band impedance budget for all the ring elements is estimated to be 0.31 Ω [2], and therefore the BPMs contribute a quite small fraction of it. By integrating the wakefield, the loss parameter of a BPM is found to be 2.7×10^{-3} V/pC. For $N = 8.3 \times 10^{10}$ and a bunch spacing of 1.2 m, this gives a power loss by the beam of 126 W. In Fig. 4, we show the impedance spectrum as a function of frequency. A sharp peak of 25 Ω is seen at around 6.8 GHz, which should be compared with the TE_{11} cutoff frequency of 6.4 GHz of an ideal coaxial waveguide with the button dimensions. The frequency and impedance of the TE_{11} mode are in satisfactory agreement with measurements [3]. The total impedance of all BPMs due to this resonant mode is 6.5 k Ω , which is about twice the accepted value calculated by Eq. 1. This resonance can be suppressed to a small value by introducing asymmetry at the button at the cost of increased mechanical complexity [4]. Since the narrow-band impedance is small compared with the feedback power (~ 100 k Ω) used for damping the RF cavity higher-order modes, we rely on the feedback system to suppress this mode.

(b) Signal and power output

In Fig. 5, we show the output signal of the TEM mode at the coaxial line as a function of time. As the beam is passing the BPM region, it generates a large output signal which then oscillates for some time and then dies off as the beam is gone. The power carried by the signal when the beam is offset by 1 cm is 37 W, which can be handled by the

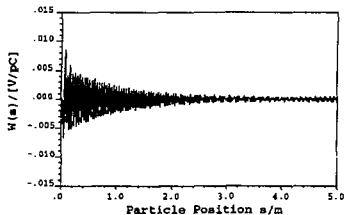

Figure 3. Longitudinal wakefield of the 1.5-cm BPM as a function of the particle position.

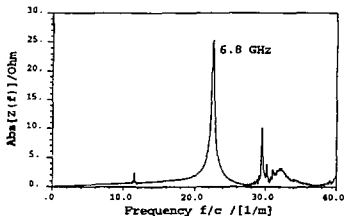

Figure 4. Longitudinal impedance spectrum of the 1.5-cm BPM as a function of the inverse wavelength.

diagnostic electronics. Fig. 6 shows the Fourier transform of the output signal divided by the beam current spectrum. The frequency content of the signal is quite broad-band and there is no evidence of high narrow peaks up to 10 GHz. In particular, at 1 GHz, the transfer impedance is 0.65 Ω , which is above our minimum requirement of 0.5 Ω .

(c) Signal sensitivity

The sensitivity of a BPM is generally determined by the signals picked up by the different monitors when the beam is off center. We define the sensitivity function as:

$$S_i = \frac{1}{d_i} \frac{(A-B)}{(A+B)}, \quad (2)$$

where i can be either x or y . For S_x , d_x is the offset in the x -direction, and A and B are the signals picked up by the top right and top left monitors respectively. For S_y , d_y is the offset in the y -direction, and A and B are the signals picked up by the right top and right bottom monitors respectively. Fig. 7 shows the sensitivity functions S_x and S_y as functions of frequency. It can be seen that the frequency dependences of S_x and S_y are similar and are extremely flat up to about 5 GHz. Their values at around 1 GHz satisfy our position resolution requirements.

IV. SUMMARY

We have shown that the 1.5-cm button type BPM has the required transfer impedance and signal sensitivity. The broad-band impedance is a small fraction of the ring impedance, and the narrow-band impedance can be suppressed by the feedback system.

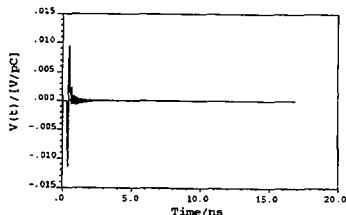

Figure 5. Voltage output of the 1.5-cm BPM at the coaxial line as a function of time.

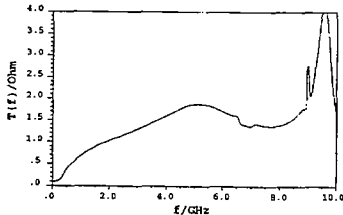

Figure 6. Beam-to-signal transfer function of the 1.5-cm BPM at the coaxial line as a function of frequency.

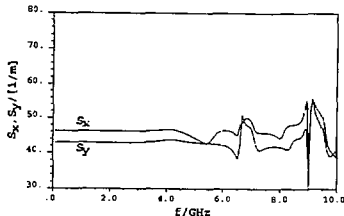

Figure 7. Sensitivity functions of the 1.5-cm BPM as functions of frequency.

Acknowledgements

We would like to thank J. Corlett, S. Heifets, K. Ko, G. Lambertson, M. Nordby, J. Seeman and T. Shintake for many useful discussions.

References

- [1] An Asymmetric B Factory, Conceptual Design Report, LBL-PUB-5379, SLAC-418, CALT-68-1896, UCRL-ID-114055 or UC-IIRPA-93-01, June 1993.
- [2] S. Heifets et. al., Impedance Budget of the PEP-II B-factory, these proceedings.
- [3] J. Corlett, private communication.
- [4] N. Kurita, D. Martin, C.-K. Ng, S. Smith and T. Weiland, Simulation of PEP-II Beam Position Monitors, PEP-II Technical Note No. 87, 1995.