

10/11/6/95 JS (1)

CONF-9506279--1

SLAC-PUB-95-7006
September, 1995

DISCLAIMER

This report was prepared as an account of work sponsored by an agency of the United States Government. Neither the United States Government nor any agency thereof, nor any of their employees, makes any warranty, express or implied, or assumes any legal liability or responsibility for the accuracy, completeness, or usefulness of any information, apparatus, product, or process disclosed, or represents that its use would not infringe privately owned rights. Reference herein to any specific commercial product, process, or service by trade name, trademark, manufacturer, or otherwise does not necessarily constitute or imply its endorsement, recommendation, or favoring by the United States Government or any agency thereof. The views and opinions of authors expressed herein do not necessarily state or reflect those of the United States Government or any agency thereof.

Numerical Simulation of the PEP-II Beam Position Monitor*

N. Kurita, D. Martin, C.-K. Ng, S. Smith
Stanford Linear Accelerator Center
Stanford University, Stanford, CA 94309, USA

and

T. Weiland
University of Technology
FB18, Schlossgartenstr. 8
D64289, Darmstadt, Germany.

Abstract

We use MAFIA to analyze the PEP-II button-type beam position monitor (BPM). Employing proper termination of the BPM into a coaxial cable, the output signal at the BPM is determined. Thus the issues of signal sensitivity and power output can be addressed quantitatively, including all transient effects and wakefields. Besides this first quantitative analysis of a true BPM 3D structure, we find that internal resonant modes are a major source of high value narrow-band impedances. The effects of these resonances on coupled-bunch instabilities are discussed. An estimate of the power dissipation in the ceramic vacuum seal under high current operation is given.

*Presented at the Workshop on Collective Effects and
Impedance for B-Factories, Tsukuba, Japan, June 12-17, 1995*

*Work supported by Department of Energy, contract DE-AC03-76SF00515.

MASTER

1 Introduction

There are several issues of concern for the button-type BPMs in the PEP-II [1] vacuum chamber. First, the presence of BPMs in the vacuum chamber contributes significant impedances, broad-band and narrow-band. For broad-band impedance, the contribution of all the BPMs to the total impedance budget can be readily calculated. Narrow-band impedances arise from the formation of resonances or trapped modes in the BPM, which may have detrimental effects on the beams because of coupled-bunch instabilities, and which may produce heating effects above tolerable levels. Second, the power coming out of the cable connected to the BPM should not be too high such that it is within the handling capability of the diagnostic electronics, but not at the expense of losing the signal sensitivity at the processing frequency of 952 MHz. Third, the power carried by the trapped modes and by the signal, especially when the beam is offset, may produce considerable heating in the ceramic and metallic walls of the BPM. These issues are closely related to each other, thus increasing the complexity of designing the BPM. In view of these electrical and mechanical requirements, BPMs with 1.5-cm diameter buttons have been selected for the PEP-II.

The paper is organized as follows. In the next section, we describe the essential features of the MAFIA modeling of the BPM. The calculations are carried out in the time domain to obtain the wakefield and other relevant information. In section 3, we present the main results of the numerical simulation. The longitudinal broad-band and narrow-band impedances, the signal sensitivity and power output at the coaxial cable are calculated. We estimate the power dissipation in the ceramic vacuum seal in section 4. A summary of the results is given in section 5. In this paper, we are mainly concerned with the electrical properties of the BPM. The mechanical design of the BPM can be found in Ref. [2].

2 MAFIA Modeling

The detailed layout of the BPM in the arcs of the PEP-II High Energy Ring (HER) is shown in Fig. 1. Each BPM consists of four buttons, located symmetrically at the top and at the bottom of the vacuum chamber. The HER arc sections have totally 198 BPMs. There are 92 BPMs in the straight sections of the HER, and the four buttons are located symmetrically at 90° from each other at the circumference of the circular pipe. The BPM button is tapered in such a way that the impedance matches that of a 50Ω coaxial line. A ceramic ring for vacuum insulation is located near the button region. It has a dielectric constant of about 9.5. The inner radius of the ceramic vacuum seal needs to be adjusted for optimum matching.

The 3D MAFIA model of the BPM is shown in Fig. 2. Because of symmetry, only one quarter of the structure is simulated. One button of the BPM is situated on the top of the vacuum chamber, and it tapers gradually to a coaxial line above. The simulation is done in the time domain, which consists of two kinds of calculations, namely wakefield and

DISCLAIMER

**Portions of this document may be illegible
electronic image products. Images are
produced from the best available original
document.**

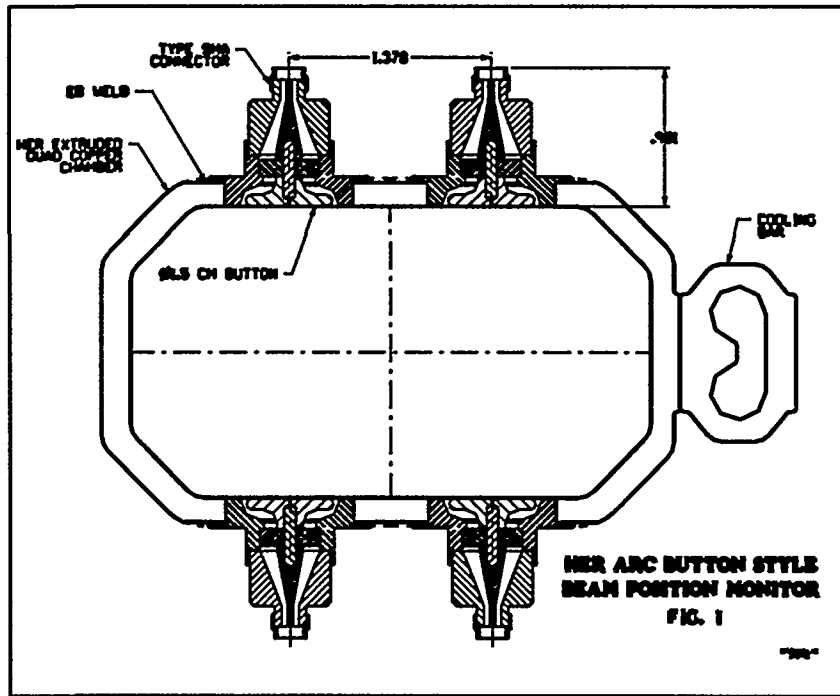

Figure 1: Layout of the 4 buttons of a BPM in the arcs of the HER vacuum chamber.

port transmission calculations. For wakefield calculation, a rigid beam comes in along the z -direction. It excites electromagnetic fields at the BPM, which in turn act back on the beam. The boundary conditions at the beam entrance and exit planes are set to waveguide boundary conditions so that electromagnetic waves traveling to these boundaries are not reflected. At the top boundary of the coaxial line, it is treated as an outgoing waveguide port, where the transmission of the signal is determined. A two-dimensional eigenvalue problem is first solved to determine the propagating and evanescent modes of the coaxial line. These modes are then loaded at the port in the 3D time domain calculation. Since the beam excites a broad frequency spectrum, a broad-band boundary has to be implemented at the waveguide port.

The impedance of a BPM can be evaluated from the wakefield or its Fourier transform. From the Fourier transform of the wakefield, we can identify potential resonant modes excited by the beam in the BPM. Since the resolution of narrow resonances in the impedance spectrum depends on the number of sampling points in the wakefield calculation, we evaluate the wakefield up to a long distance of $s = 5$ m, where s is the bunch coordinate. The transmission calculation at the port gives us the value of the outgoing voltage at the end of the coaxial line as a function of time, which corresponds to the signal picked up by the BPM as the beam passes through this region of the vacuum chamber.

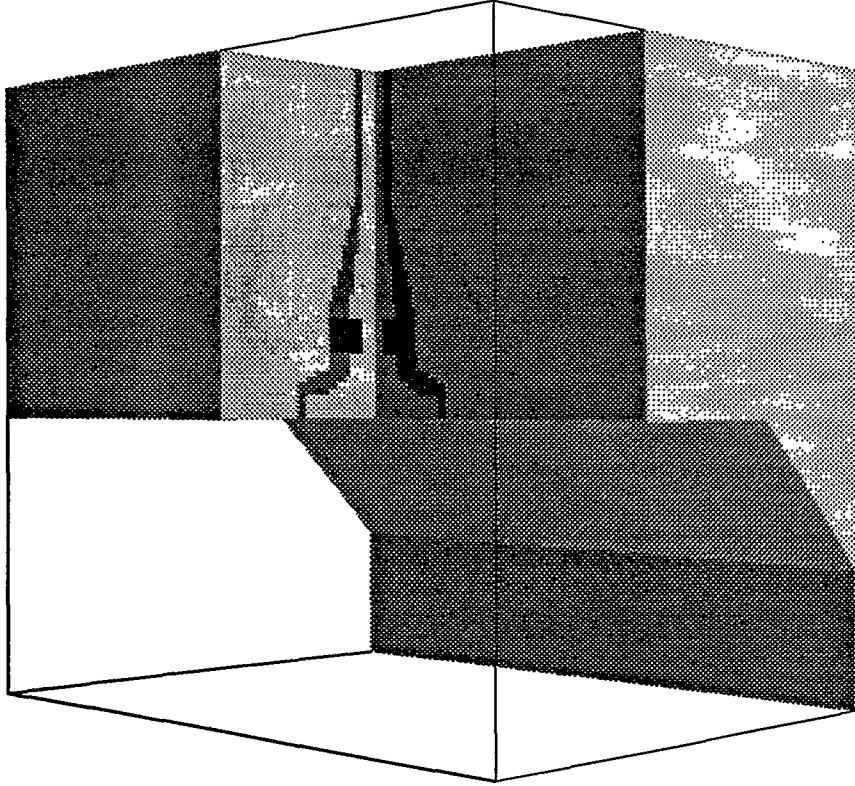

Figure 2: 1/4 MAFIA geometry of the BPM in the vacuum chamber. The button region is cut out for viewing purposes:

3 Longitudinal Impedances

The high beam current in the PEP-II B-Factory poses stringent requirements on impedances and power deposition. BPMs can generate considerable broad-band and narrow-band impedances. To avoid single-bunch instabilities, the accepted limit of the total broad-band effective impedance for the prescribed PEP-II current is $|Z/n|_{eff} = 0.5 \Omega$ [1], where $n = \omega/\omega_{rev}$ is the harmonic number. It is desirable that BPMs contribute a small fraction to the total broad-band impedance budget. Narrow-band impedances can also be generated as a result of the excitation of trapped modes in the BPMs. Their values have to be controlled below some limits so that coupled-bunch instabilities will not occur. The most serious higher-order mode excited by the beam is the TE_{11} mode with respect to the button axis. Its frequency increases with a decrease in the diameter of the button. The acceptable limit of the narrow-band impedance for avoiding coupled-bunch instabilities is a function of the frequency $f = \omega/2\pi$ of the resonant mode and is given by [3]:

$$\left(\frac{Re[Z]}{k\Omega}\right) < 3.0\left(\frac{GHz}{f}\right)e^{(\omega\sigma_z/c)^2}, \quad (1)$$

where σ_z is the bunch length. It should be noted that the above limit is a conservative

estimate since it takes into account of only radiation damping. Other damping mechanisms such as feedback will help suppress the narrow-band resonance. The numerical factor is given for the Low Energy Ring (LER) with a current of 3 A, and the limit is inversely proportional to the current. The exponential factor indicates the decay of the beam spectrum at high frequencies.

In the following, we present the numerical results from MAFIA simulations. In our simulations, a Gaussian bunch with $\sigma_z = 1$ cm is used and the total bunch length is 10σ 's. For the coaxial port, at the range of frequency of interest, only the TEM mode propagates. Thus for the output signal at the coaxial line, we only need to consider this mode. The MAFIA results shown in the following figures are normalized to a bunch charge of 1 pC. The numerical results for impedance, power and other relevant quantities for the case with 3 A current (8.3×10^{10} per bunch) are listed in Table 1.

Energy loss by beam	126 W
Power out of one cable	9 W (37 W)*
Transfer impedance at 952 MHz	0.65 Ω
Broad-band impedance, $ Z/n $	0.008 Ω (11 nH)
Narrow-band impedance:	MAFIA accepted
	6.5 k Ω at ~ 6.8 GHz 3.4 k Ω

Table 1: Impedance and power of the 1.5-cm BPM. The beam current is 3 A. The impedances are for all the BPMs in the ring. *The power in the parentheses is that out of the cable which is closest to the beam when it is 1 cm offset from the axis.

In Fig. 3, we show the longitudinal wakefield as a function of the beam coordinate s . It can be seen that, for $0 \lesssim s \lesssim 10\sigma$, the wakefield is roughly inductive. The inductance of each BPM is estimated to be 0.04 nH or $|Z/n| = 3.4 \times 10^{-5}\Omega$. The total contribution of all the BPMs is 11 nH or $|Z/n| = 0.008\Omega$. The total broad-band impedance budget for all the ring elements is estimated to be 0.31Ω [4], and therefore the BPMs contribute a quite small fraction of it. By integrating the wakefield, the loss parameter of a BPM is found to be 2.7×10^{-3} V/pC. For $N = 8.3 \times 10^{10}$ and a bunch spacing of 1.2 m, this gives a power loss of 126 W by the beam. In Fig. 4, we show the impedance spectrum as a function of frequency. A sharp peak of 25 Ω is seen at around 6.8 GHz, which should be compared with the TE_{11} cutoff frequency of 6.4 GHz of an ideal coaxial waveguide with the button dimensions. The frequency and impedance of the TE_{11} mode are in satisfactory agreement with measurements [5]. The total impedance of all BPMs due to this resonant mode is 6.5 k Ω , which is about twice the accepted value calculated by Eq. 1. This resonance can be suppressed to a small value by introducing asymmetry [6, 7] at the button at the cost of increased mechanical complexity. Since the narrow-band impedance is small compared with the feedback power (~ 100 k Ω) used for damping the RF cavity higher-order modes, we rely on the feedback system to suppress this resonance.

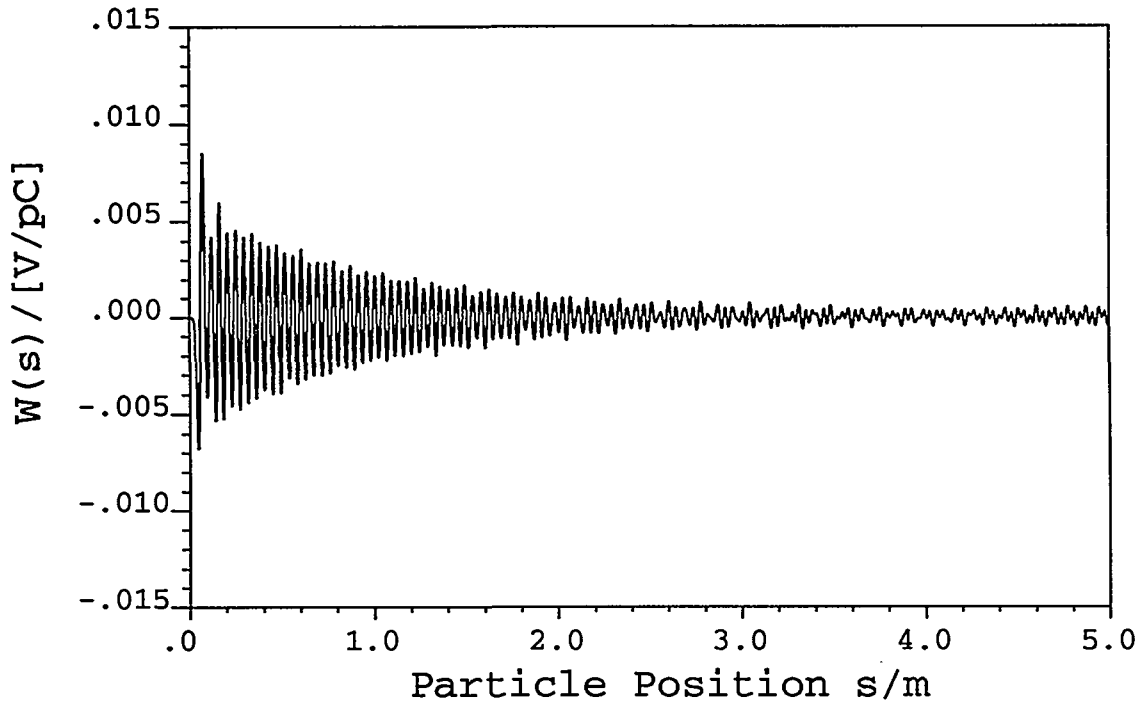

Figure 3: Longitudinal wakefield of the 1.5-cm BPM as a function of the particle position for a Gaussian bunch with $\sigma_z = 1$ cm.

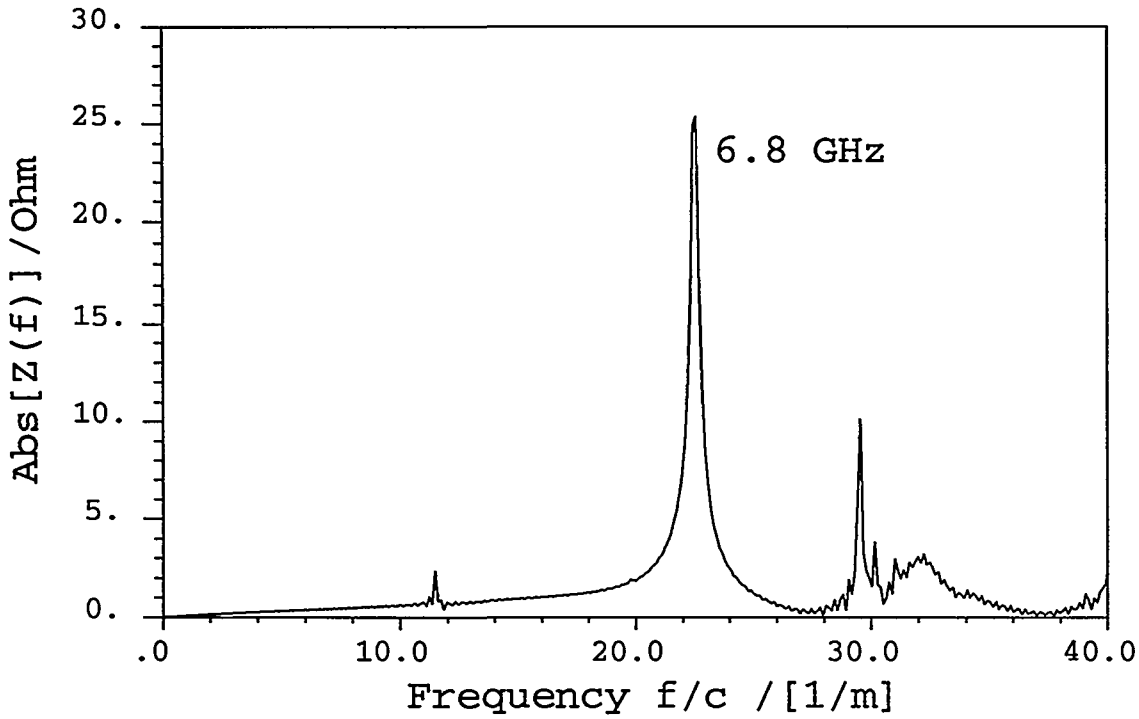

Figure 4: Longitudinal impedance spectrum of the 1.5-cm BPM as a function of the inverse wavelength for a Gaussian bunch with $\sigma_z = 1$ cm.

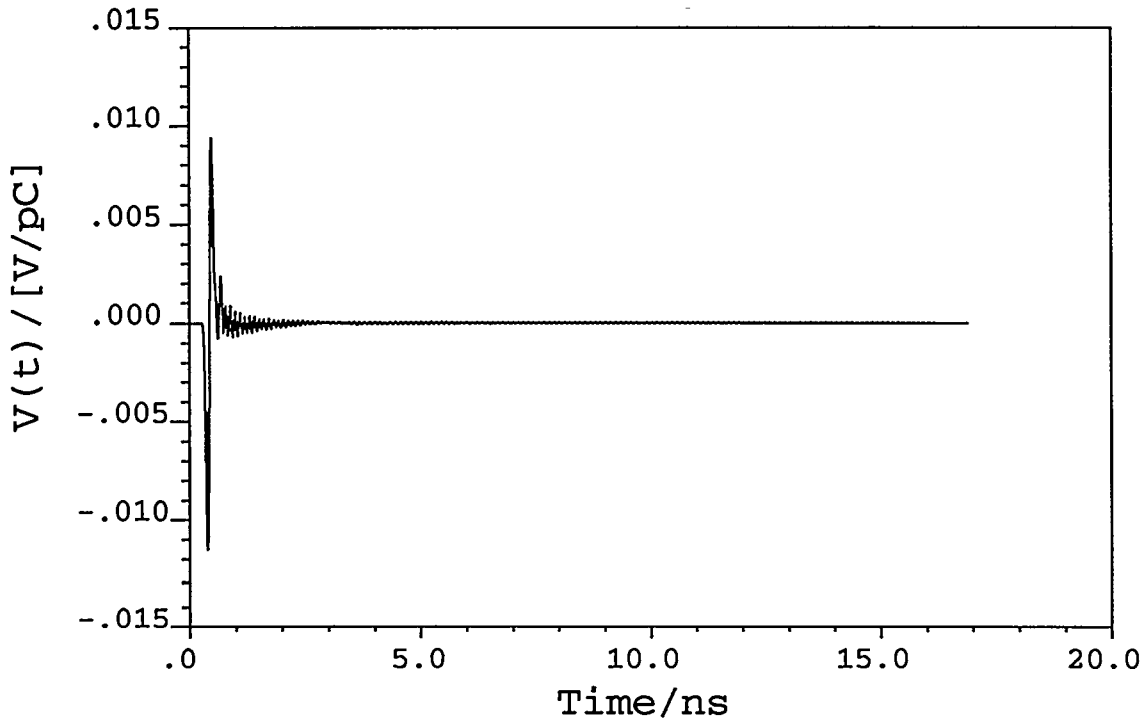

Figure 5: Voltage output of the 1.5-cm BPM at the coaxial line as a function of time.

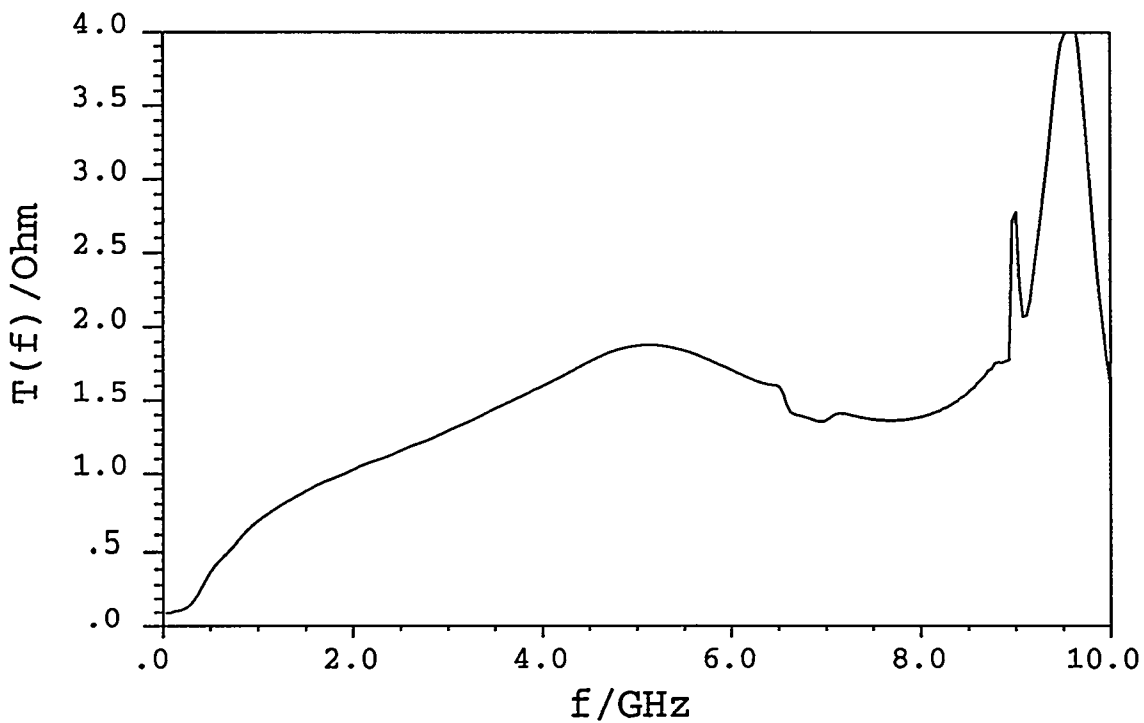

Figure 6: Beam-to-signal transfer function of the 1.5-cm BPM at the coaxial line as a function of frequency.

4 Signal and Power Output

In Fig. 5, we show the output signal of the TEM mode at the coaxial line as a function of time. The signal dies off rapidly after the transient excitation during the passage of the beam. The power output can be evaluated by integrating the signal voltage over time. When the beam is offset from the center of the chamber, the monitor closest to the beam will transmit the highest power. The power carried by the signal for this monitor for an 1 cm offset beam is 37 W, which can be handled by the diagnostic electronics. Fig. 6 shows the Fourier transform of the output signal divided by the beam current spectrum. The frequency content of the signal is quite broad-band and there is no evidence of high narrow peaks up to 10 GHz. In particular, at 952 MHz, the transfer impedance is 0.65Ω , which is above our minimum requirement of 0.5Ω .

The sensitivity of a BPM is generally determined by the signals picked up by the different monitors when the beam is off center. We define the sensitivity function as:

$$S_i = \frac{1}{d_i} \left(\frac{A - B}{A + B} \right), \quad (2)$$

where i can be either x or y . For S_x , d_x is the offset in the x -direction, and A and B are the signals picked up by the top right and top left monitors respectively. For S_y , d_y is the offset in the y -direction, and A and B are the signals picked up by the right top and right bottom monitors respectively. Fig. 7 shows the sensitivity functions S_x and S_y as functions of frequency. It can be seen that the frequency dependences of S_x and S_y are similar and are extremely flat up to about 5 GHz. Their values at 952 MHz satisfy our position resolution requirements.

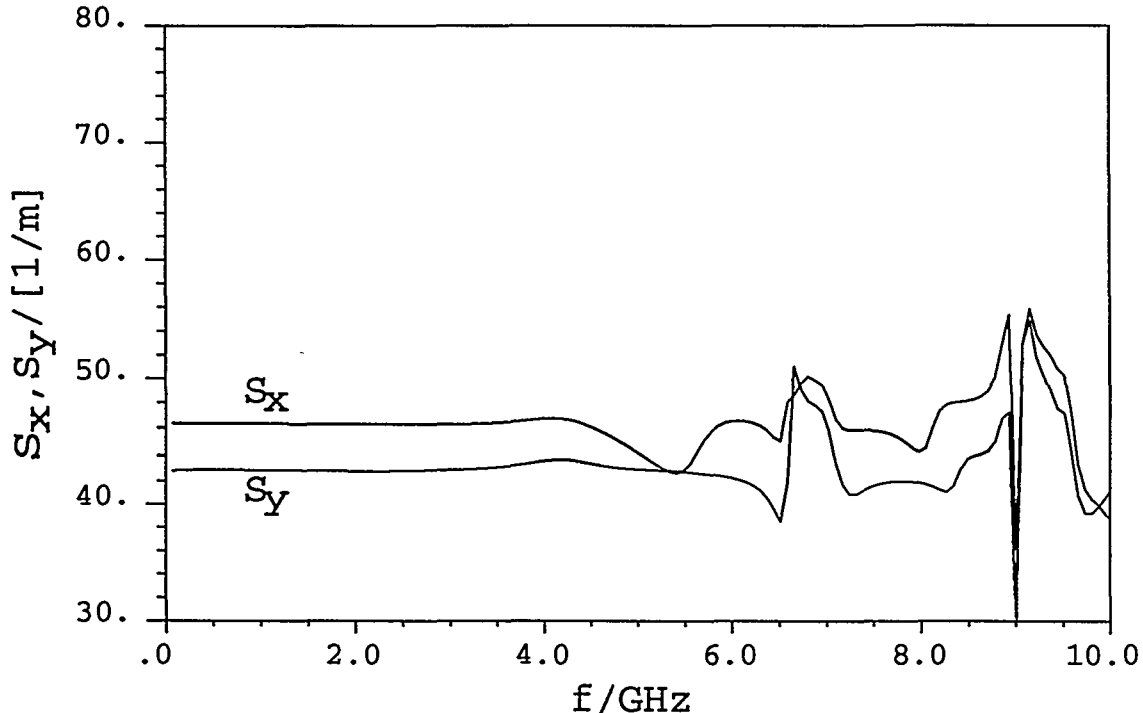

Figure 7: Sensitivity functions of the 1.5-cm BPM as functions of frequency.

5 Power Dissipation

The high power throughput of the signal and the presence of HOMs in the BPM may generate considerable heating effects. Due to the transient behavior of the problem, the calculations of the power loss in the ceramic and in the metallic walls are carried out by fourier-transforming the time evolutions of the electromagnetic fields in the BPM. The energy dissipation in the ceramic during a single bunch crossing is given by:

$$P = \int \omega \epsilon_i(\omega) |\vec{E}_\omega(\vec{x})|^2 \frac{d\omega}{2\pi} d\vec{x}, \quad (3)$$

where

$$\vec{E}_\omega(\vec{x}) = \int \vec{E}(\vec{x}, t) e^{i\omega t} dt, \quad (4)$$

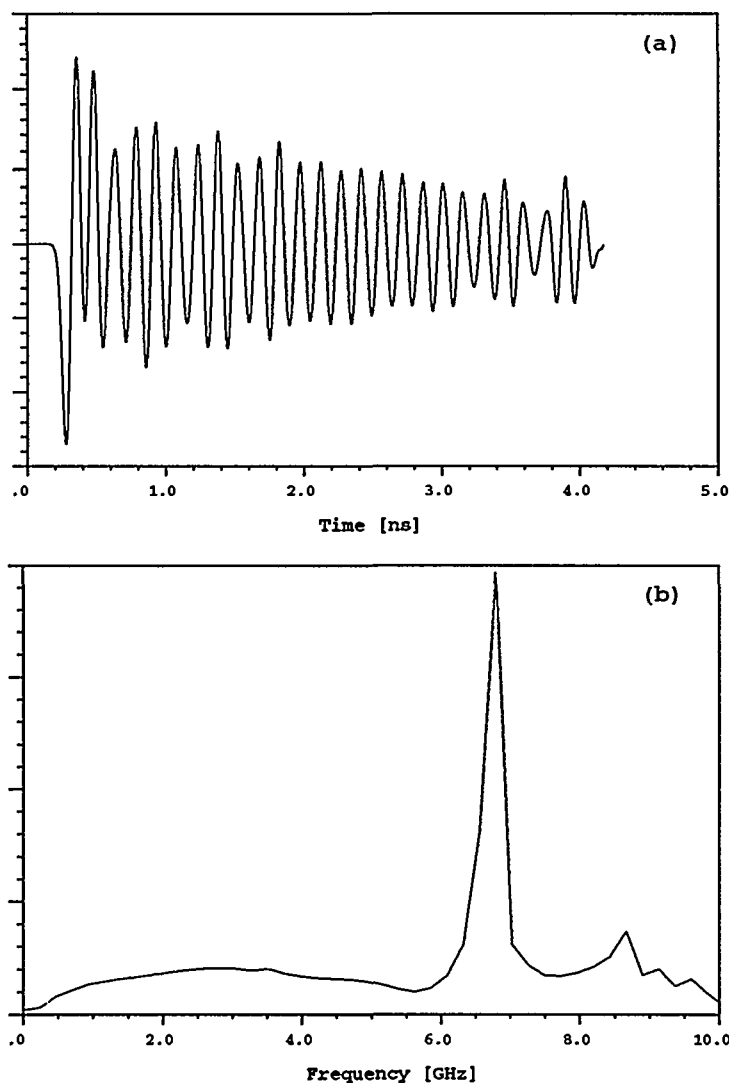

Figure 8: (a) The time history of the electric field and (b) its Fourier transform for a typical location in the ceramic vacuum seal.

and ϵ_i is the imaginary part of the dielectric constant. The time dependence of the electric field and its Fourier transform at a typical location in the ceramic vacuum seal is shown in Fig. 8. A resonant peak appears in the Fourier spectrum, corresponding to the trapped TE mode in the BPM. Since the Q value of the resonance is about 100, we do not expect heating enhancement due to multi-bunch effects. Therefore it is sufficient to use the above formulas to determine the power dissipation. Assuming the ceramic has a dielectric constant of 9.5 and a loss tangent of 0.0007, we find that the ceramic loss is ~ 0.35 W when the beam is offset by 1 cm at 3 A. At the junction of the ceramic and inner molybdenum center pin where heating effects are of more concern than the outer wall, the power loss is found to be ~ 0.007 W, assuming copper conductivity. The introduction of other material such as nickel on the surface of the center pin will increase the power dissipation roughly by an order of magnitude. ANSYS were used to estimate the thermal and structural stabilities of the BPM under these conditions with an additional heat source of 0.25 W/cm² from scattered synchrotron radiation. A maximum temperature of 110°C was found on the button and a temperature gradient of about 30°C in the ceramic. ANSYS simulations showed that the temperature and stress distributions are acceptable [2].

6 Summary

We simulated the PEP-II BPM using MAFIA and showed that the 1.5-cm button type BPM has the required transfer impedance and signal sensitivity. The broad-band impedance is a small fraction of the ring impedance, and the narrow-band impedance can be suppressed by the feedback system. The power dissipated in the ceramic vacuum seal was estimated, and temperature and stress distributions were found to be acceptable from ANSYS simulations.

Acknowledgements

We would like to thank J. Corlett, S. Heifets, K. Ko, G. Lambertson, M. Nordby, J. Seeman and T. Shintake for many useful discussions.

References

- [1] An Asymmetric B Factory, Conceptual Design Report, LBL-PUB-5379 or SLAC-418, June 1993.
- [2] N. Kurita et. al., Design of the Button Beam Position Monitor for PEP-II, to be published in Proc. of PAC95.
- [3] S. Heifets, Estimate of the Wakefield Tolerances, AP-99 (1994).
- [4] S. Heifets, Broad Band Impedance of the B-Factory, SLAC/AP-93 (1992).
- [5] J. Corlett, these proceedings.
- [6] T. Shintake et. al., these proceedings.
- [7] N. Kurita et. al., Simulation of PEP-II Beam Position Monitors, PEP-II Technical Note No: 87, 1995.