



FUEL BUNDLE EXAMINATION TECHNIQUES FOR THE PHEBUS FISSION PRODUCT TEST

J.Y. BLANC

Commissariat à l'Energie Atomique,
Gif-sur-Yvette

B. CLÉMENT

Institut de Protection et de Sûreté Nucléaire
CEA/Cadarache, Saint-Paul-lez-Durance

P. VON DER HARDT

European Commission Joint Research Centre Ispra
CEA/Cadarache, Saint-Paul-lez-Durance

France

Abstract

Post-test analyses in the Phebus Fission Product experiments concentrate on the studies of the circuits where the fission products are transferred after leaving the core. Nevertheless, the examination of the degraded fuel bundle is a key feature when considering source term, mass balances, physical and chemical aspects of the molten fuel rods, and temperatures reached.

Post-irradiation testing of the first fuel bundle consisted of on-site non destructive examinations, sectioning in the Cadarache hot cells, and destructive examinations at Saclay. In future, the Transuranium Institute in Karlsruhe will participate through detailed investigations, including x-y gamma mapping, autoradiography, optical and electronic microscopy, Electron Probe Micro Analysis, and chemical analyses on microdrilled samples.

The paper will develop the non-destructive examinations, with a special emphasis on transmission tomography, performed in the Phebus facility, using a linear accelerator associated with a line scan camera based on PCD components. This particular technique enabled the high level of penetration to be obtained, necessary for this high density application. Spatial resolution is not far from the theoretical limit and the density resolution is often adequate.

This technique permitted : 1) to define beforehand the cuts on a precise basis, avoiding a long step-by-step choice as in previous in-pile tests, 2) to determine, at an early stage, mass balance, material relocations (in association with axial gamma spectrometry), and FP distribution, as an input into re-calculations of the bundle events.

However, classical cuttings, periscopic visual examinations, macrographies, micrographies and EPMA analyses remain essential to give oxidation levels (in the less degraded zones), phase aspect and composition, to distinguish between materials of identical density, and, if possible, to estimate temperatures. Oxidation resistance of sensors (thermocouples or ultrasonic thermometers) is also traced. The EPMA gives access to the molten material chemical analyses, especially in the molten fuel blockage area.

The first results show that an important part of the fuel bundle melted (which was one of the objectives of this test) and that the degradation level is close to TMI-2 with a molten plug under a cavity surrounded by an uranium-rich crust. In lower and upper areas fuel rods are less damaged. Complementarities between these examination techniques and between international teams involved will be major advantages in the Phebus FPT0 test comprehension.

1. INTRODUCTION

Post-test analyses in the Phebus Fission Product experiments [1,2] concentrate on the studies of the circuits where the fission products are transferred after leaving the core. Nevertheless, the examination of the degraded fuel bundle is a key feature when considering source term, mass balances, physical and chemical aspects of the molten fuel rods, and temperatures reached.

Post-irradiation testing of the first fuel bundle consists of on-site non destructive examinations, sectioning in the Cadarache hot cells, and destructive examinations at Saclay and Karlsruhe.

2. BRIEF SUMMARY OF THE PHEBUS FPT0 TEST

The FPT0 test, performed in December 1993, contained a 20 fuel rod bundle, with a central Ag-In-Cd absorbing rod. The fresh, 1 meter-long fuel rods were only irradiated during 9 days before the accident scenario. Degradation events included three heat up phases up to 900°C, from 900°C to 2000°C, and from 2000°C to 2800°C, followed by a late phase, and a cooling phase. Total duration of the transient was 5 h 40 mn.

The paper will develop the post-test non-destructive examinations on the fuel bundle, with a special emphasis on transmission tomography.

3. NON-DESTRUCTIVE EXAMINATIONS

In the Phebus reactor hall, a fuel examination facility, called "PEC" has been built for the FP project. After the FPT0 experiment, the test train was transferred to the "PEC". As the test bundle was not yet embedded in epoxy, special care has been taken during the transfer from the Phebus loop, using a very low speed overhead crane.

This facility has three possibilities of analyses : numerical radiography by translation of the test train, computed tomography by rotation and axial gamma-scanning.

For tomography and radiography (Fig. 1), a linear electron accelerator CGR Neptune 6 was rented. Its energy and dose rates are adapted to the significant amount of dense material to be penetrated, and to the sensitivity of camera optic sensors. Its main characteristics are the following : maximum energy = 5.5 MeV, average energy = 1.7 MeV, source of 2 mm², dose rate = 600 rads/mn at 1 m, primary collimation between source and bundle : height = 2 mm, depth = 300 mm.

The linear camera has two PCD components covered with scintillators, with 1024 photo-sensitive diodes per component. The width of each component is 51.2 mm (total width = 102.4 mm). The thickness of the scintillator layer is 0.3 mm. A personal computer, situated in the reactor hall, controlled the acquisitions and displacements of test train and camera.

A calibration in density was performed, using a lead cone to obtain density and distance as a polynomial fonction. Bundle attenuation is up to 9 cm lead equivalent.

Numerical radiography was performed by vertical translation of the bundle, with 1 projection per mm, 682 pixels/projection, and an acquisition time of 3 hours. In future tests, the resolution can be improved, by a reducing of the axial step.

Each tomography is built from 900 measurements acquired in one turn of the test train under the beam (i.e. one step each 0.4°). The test train has an overall width of 122 mm. The

principles of data acquisition

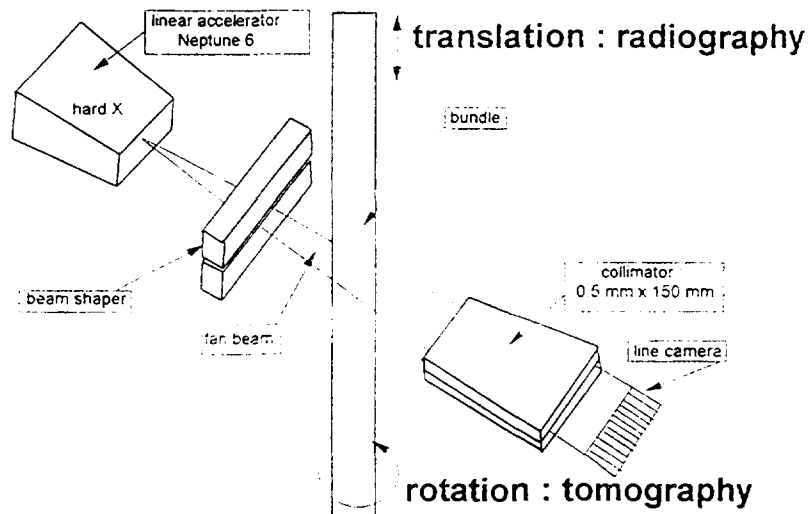

principle of a line scan camera with integrated collimator and edge-on illumination of the scintillator

(Initially developed by L. Steinbock/KFK)

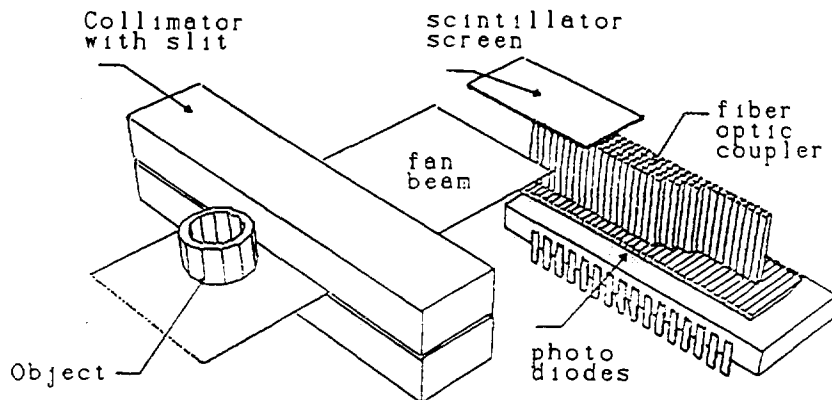

Fig. 1 : Phebus FPTO - Computed tomography and numerical radiography.

electron beam has a width of 150 mm, but the camera is limited to 102.4 mm, so it was necessary to off-center the camera from 19 to 26 mm to see the whole object in one turn. Acquisition time of one projection lies between 6 and 22 s, depending of the section mean attenuation. As the camera has a limited dynamic, it was proceeded by accumulation of short duration acquisitions. For a single tomography, the acquisition time varied between 2 and 5 hours (in the molten pool area).

The result is a 2.5 Mbyte file, which is computed to give a tomographic reconstruction in about 11 mn on a PC DX2 66 MHz. Main steps of the computed tomography reconstruction are : 1) fan-beam correction, 2) Fourier transform, 3) filtering, 4) inverse Fourier transform, and 5) back -projection. The method was beforehand validated on two mock-ups, of similar geometry, realized with materials of similar density. The first mock-up was simulating a non degraded bundle, and the second a molten pool.

52 tomographies were taken, with excellent results. Three kinds of imperfections were detected : 1) edge problems, when the off-centering of the camera is poorly estimated : it leads to density error on the inconel tube, with no incidence on bundle results, 2) rotation problems, leading to poor image quality, 3) circular artefact, due to misalignment of the two PCD components and short acquisition times ; this will be improved in the future test campaigns. Other improvements are under way, mainly concerning acquisition time reduction and density resolution by a new concept of line scan camera and also geometrical resolution by new computing environment.

It is also envisaged in future test to performed ECT : emission computed tomography (i.e. without an external source as transmission method), but the acquisition time is estimated to 1 week per section.

Gamma scanning of the bundle was performed, mainly looking for Zr-95 (fuel distribution), Co-60 (axial profile during irradiation phase), Ba-140, Nb-95, La-140, Ru-103 and Ag-110m. Cesium, iodine and tellurium were not measurable. Hypothesis were introduced about the localisation of the gamma emitters in the section of the bundle. These estimated self shielding coefficients were taken from the 50 tomodensitometries measured all along the bundle. If ECT is performed next time, an improvement of the quantitative estimation can be expected. A planning minimizing the decay time problem will also be looked for.

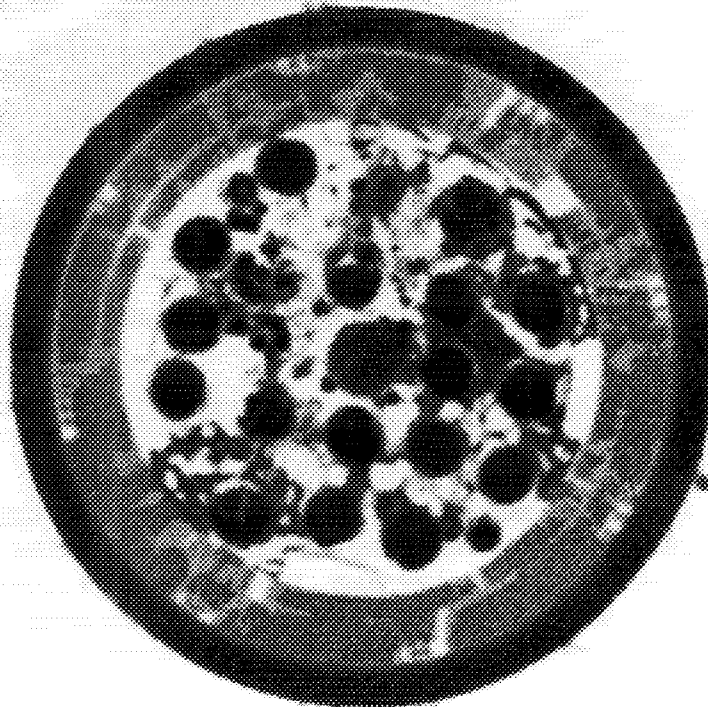

Fig. 2 : Phebus FPT0 - Computed tomography at level + 88 mm bfc.

Downward view - Bundle orientation : North at the top

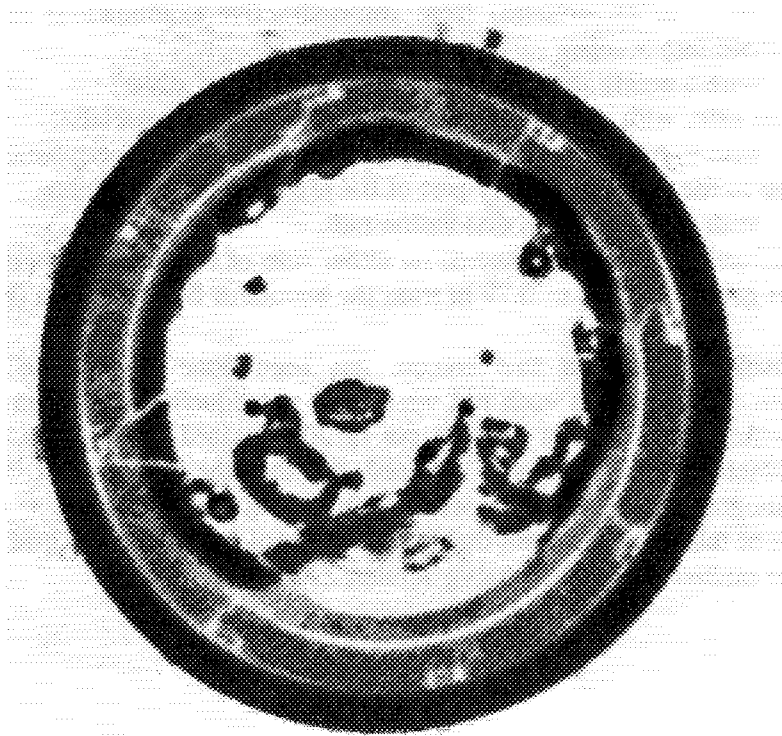

Fig. 3 : Phebus FPT0 - Computed tomography at level + 268 mm bfc.

Downward view - Bundle orientation : North at left

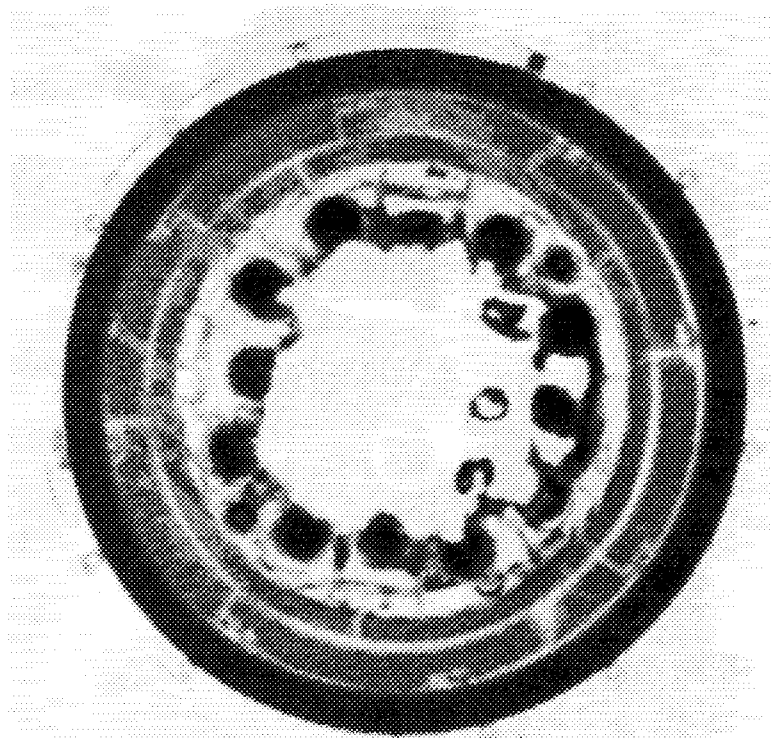

Fig. 4 : Phebus FPT0 - Computed tomography at level + 772 mm bfc.

Downward view - Bundle orientation : North at left

Results (Fig. 2 to 4), obtained from non-destructive examinations showed that the fuel bundle can be divided into 5 zones :

- 1) the lower part, with a nearly intact geometry (and presence of silver) ;
- 2) below the lower grid, with an accumulation of fuel and molten materials ;
- 3) from the lower grid to mid-plane, no more rods are present, but a peripheral crust,
- 4) from mid-plane to the upper grid, only part of the external rods are visible,
- 5) the upper part, with rods with high dissolution rate.

Before the test, Zircaloy grids were located on either side of mid-plane : lower grid from 0.23 to 0.27 m and upper grid from 0.75 to 0.79 m from the bottom of fissile column (bfc).

An estimation of molten fuel amount has been done from these results : on each tomographic level, the amount of each rod which was not liquefied or molten was determined. It showed that an equivalent of about 13 rods out of 20 remained solid. Then, by integration, the amount of fuel which remained solid was obtained, and then the total amount of molten fuel. Mass balances used tomographies for materials with density $> 6\text{g/cm}^3$, i.e. $\text{UO}_2 + \text{AgInCd} + \text{stainless steel}$. Conclusion of this work indicates that the molten pool near the lower grid can be evaluated to 2.4 ± 0.5 kg of molten UO_2 not including molten ZrO_2 .

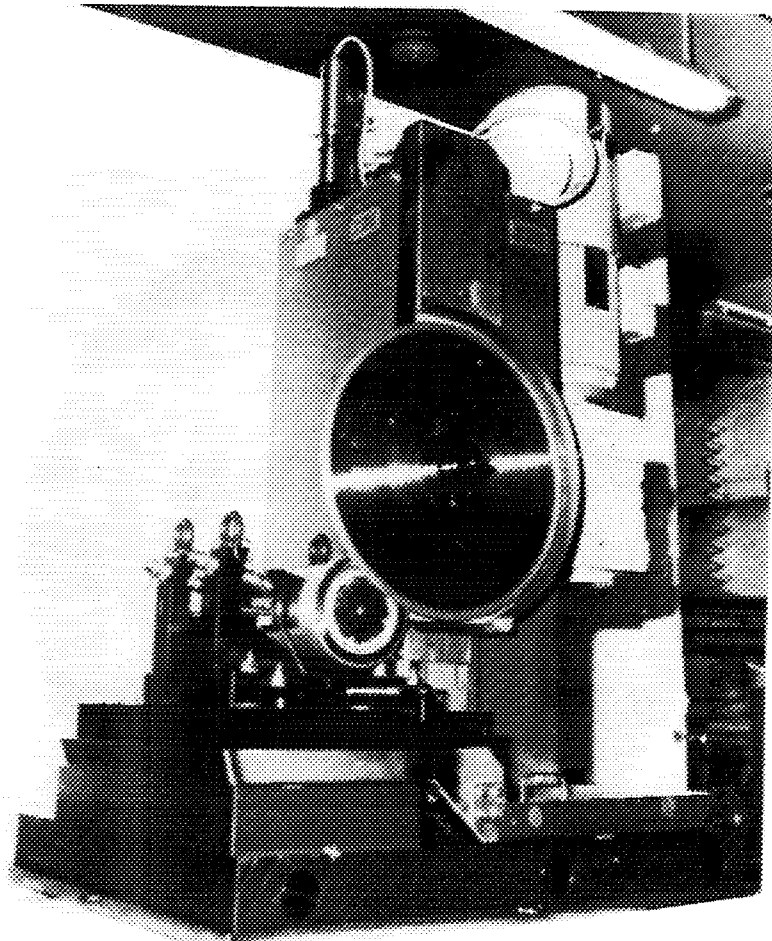

Fig. 5 : Cutting machine for Phebus destructive examinations before implementation in Saclay hot cells.

These techniques, and especially the computed transmission tomography, permitted: 1) to define beforehand the cuts on a precise basis, avoiding a long step-by-step choice as in previous in-pile tests, 2) to determine, at an early stage, mass balance, material relocations (in association with axial gamma spectrometry), and FP distribution, as an input into re-calculations of the bundle events.

4. DESTRUCTIVE EXAMINATIONS

In fall 1994, the lower part of the test train, including the fuel bundle, was embedded in epoxy in the PEC facility, and transferred to the LECA hot cells at Cadarache. Besides cutting out some tube samples for deposit analyses in the upper part of the test train, two saw cuts were realized about 10 cm above and below the fuel rods. Then the bundle was sent to Saclay in early February 1995. It can be pointed out that the epoxy embedding gives some limitations in criticality allowance in hot cells.

At Saclay, two cuts were realized at first at the bottom of the fuel rods to define more precisely the original levels for future sectionning, then a mid-plane cut enabled an easier handling of the bundle. Finally, a total of 19 section cuts were done, with a majority in the lower areas showing highly oxidized cladding in the nearly intact geometry zone, and previously molten fuel in the molten pool area. A cutting saw using a 2 mm-thick diamond disk, with lubrication was employed (Fig. 5). Another cut, in vertical position is to be done in the molten pool area in the near future.

Periscopic photographs ($\times 1$ to $\times 3$) have been taken on all 19 slices both from the top and the bottom of each slice. The quality of the cut was sufficient to avoid polishing before photographs. Most of the cut levels being chosen from tomographic results, comparison between tomographies and photographs of cut at similar elevations are of particular interest (Fig. 6 to 9). It shows that the tomographies were representative of the real state of the bundle, although a better choice in the colours attributed to densities could be discussed.

However, cuts and photographs and further examinations remain essential to give oxidation levels (in the less degraded zones), phase aspect and composition, to distinguish between materials of identical density, and, if possible, to estimate temperatures. Oxidation resistance of sensors (thermocouples or ultrasonic thermometers) is also traced.

On the most interesting slices, areas are defined for further optical macrographies and micrographies (typically $\times 100$ and $\times 400$). Due to apparatus limitations, the sample is re-cut to approximately 20 mm \times 20 mm. Two samples have been examined by June 1995: the first in the area above the blockage zone, where a void volume is surrounded by a crust, somewhat similar to TMI-2, and the second in the molten pool area, showing some metallic inclusions.

During discussions on micrographies, TransUranium Institute in Karlsruhe (TUI) suggested to perform a specific chemical etching on the previously molten materials, using a mixture of HNO_3 50%, H_2O_2 49% and HF 1% during 5 s to 2 mn. This etching was told to be useful for the two-phase system $a\text{Zr(O)} - (\text{U,Zr})\text{O}_{2-x}$.

After metallography, the sample is polished again, cut to limit its thickness (and radioactivity) and sent to the EPMA (Electron Probe Micro Analysis). This gives access to the molten material chemical analyses (either in weight per cent or atomic per cent), especially in the molten fuel blockage area. The zirconia shroud surrounding the fuel is useful as a standard for checking the EPMA results : actually, its chemical analyses before the test are perfectly well known, and as temperatures in this area were significantly lower than in the bundle itself, it can be hypothesized that shroud chemical composition remained stable.

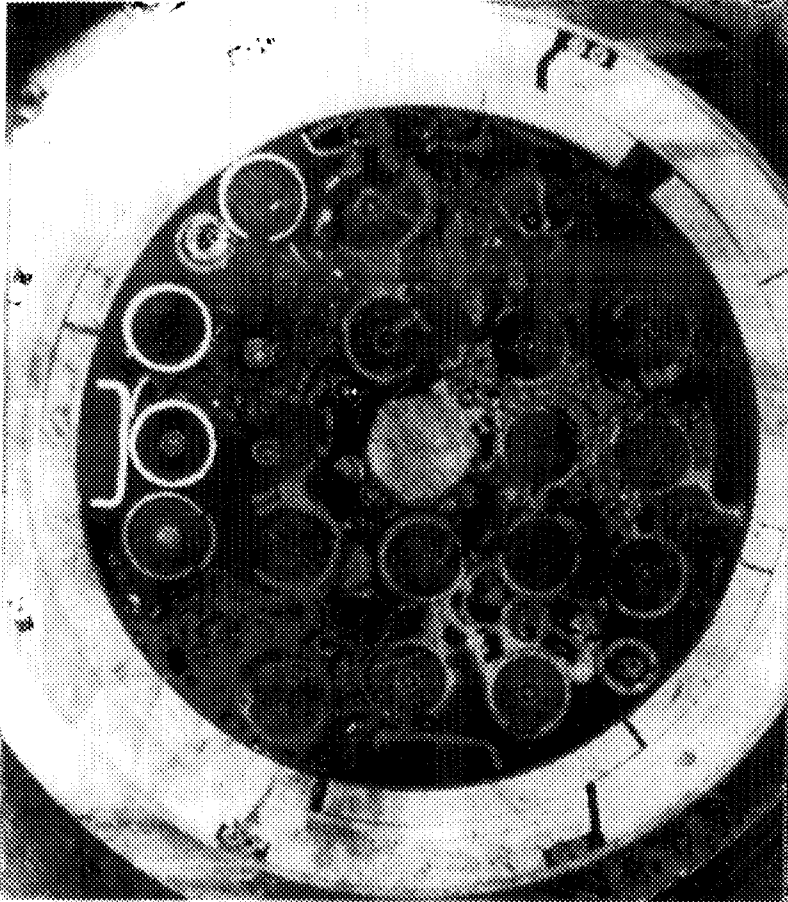

Fig. 6 : Phebus FPTO - Periscopic photography at + 89 mm bfc.
Downward view - Bundle orientation : North at the top

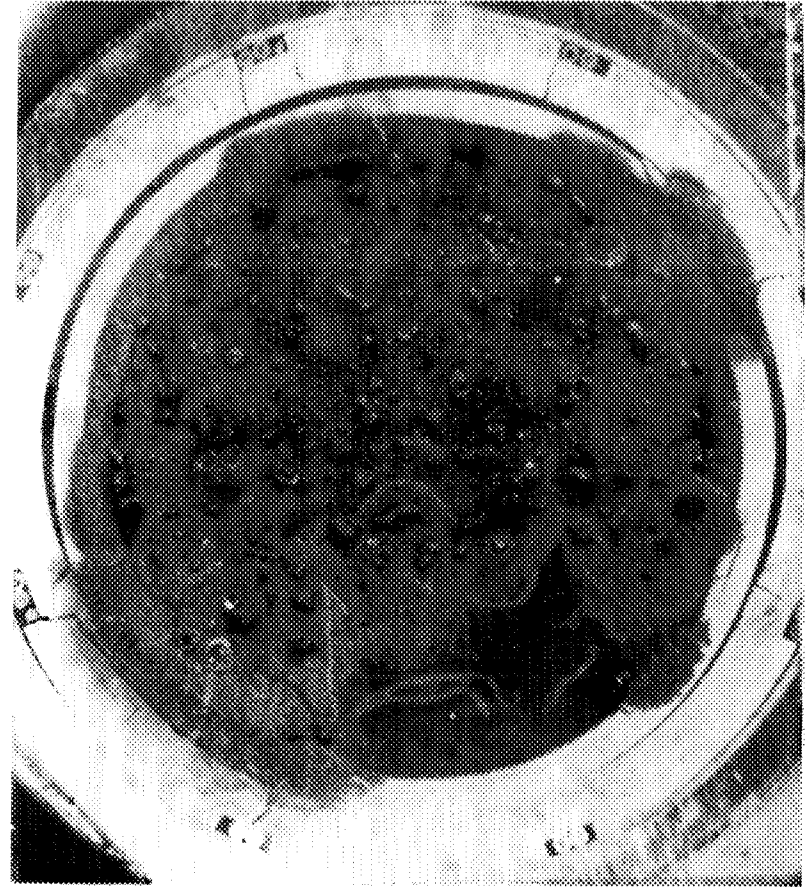

Fig. 7 : Phebus FPTO - Periscopic photography at + 250 mm bfc.
Downward view - Bundle orientation : North at left

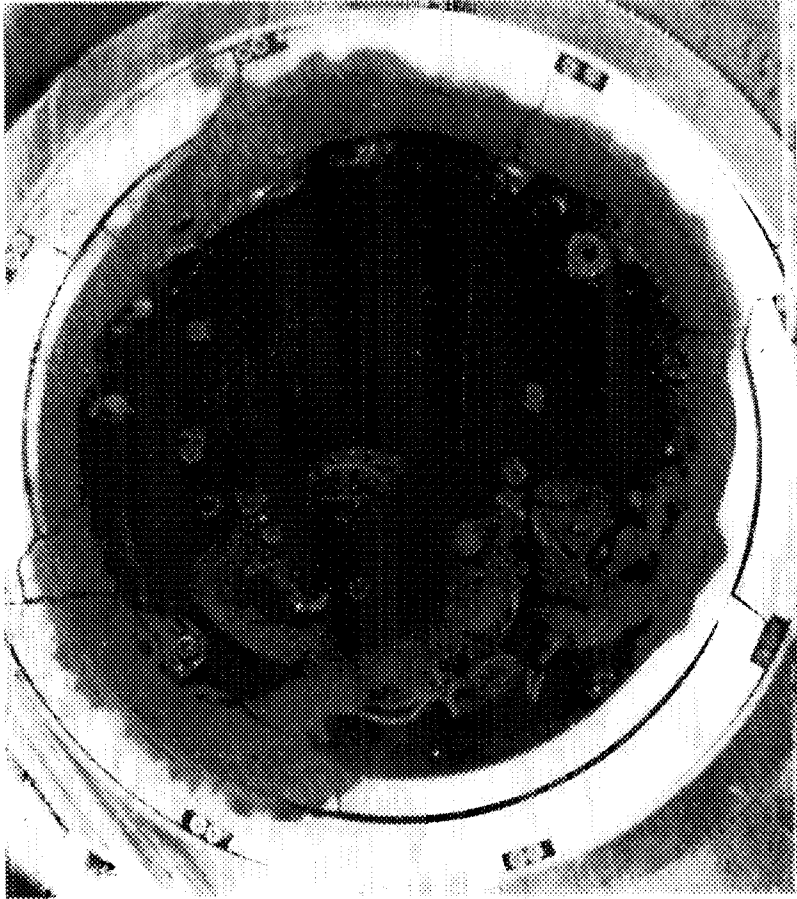

Fig. 8 : Phebus FPTO - Periscopic photography at + 268 mm bfc.
Downward view - Bundle orientation : North at left

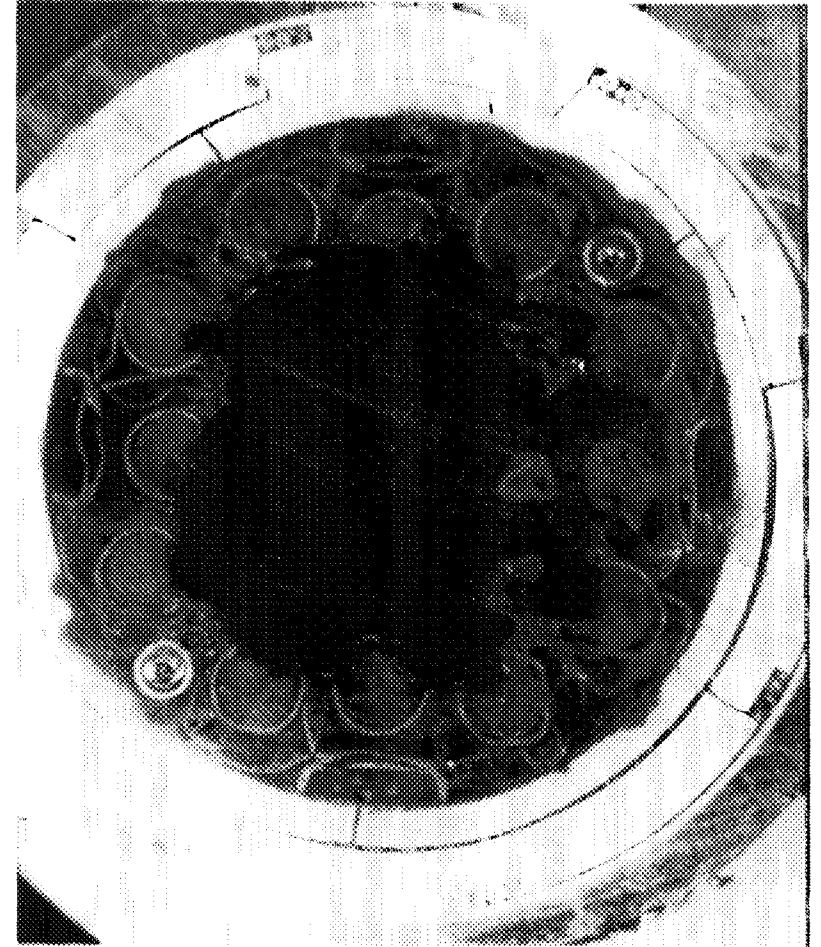

Fig. 9 : Phebus FPTO - Periscopic photography at + 773 mm bfc.
Downward view - Bundle orientation : North at left

However, the epoxy embedding leads to some limitation in EPMA analyses, because epoxy is non-conductive. This difficulty is overcome by performing linescans on points selected manually, out of non-conductive areas (epoxy, void, porosities). The first results on the crust show a quite homogeneous previously molten material, composed of U, Zr and O. The specific etching, recommended by TUI, having revealed a limited area in the crust, some EPMA was performed in that part, but only an increase in iron (or steel) impurities was noticeable.

A second EPMA will be performed in the previously molten bath, essentially for its chemical composition, and for tracing the metallic particules, visible on metallography.

In fall 1995, a slice taken from the lower part of the bundle, in the area at the bottom of the molten pool will be shipped to the Transuranium Institute in Karlsruhe. This laboratory will participate through detailed investigations, including x-y gamma mapping, autoradiography, optical and electronic microscopy, Electron Probe Micro Analysis, and chemical analyses on microdrilled samples.

5. CONCLUSIONS

The first results show that an important part of the fuel bundle melted (which was one of the objectives of this test) and that the degradation level is close to TMI-2 with a molten plug under a cavity surrounded by an uranium-rich crust. In lower and upper areas fuel rods are less damaged.

Complementarities between these examination techniques and between international teams involved is a major asset for the understanding of the Phebus FPT0 test comprehension [3].

ACKNOWLEDGEMENTS

Most of the work described in the non-destructive part is taken out restricted reports from B. Cornu, I. Giacalone (tomography) and G. Répetto (bundle degradation). The principle of the line scan camera described above was initially developed by L. Steinbock/KfK. Destructive examination in Saclay are indebted to J. Y. Latarse, R. Cozler, J. M. Boyer, D. Gauvain and M. Perrot.

REFERENCES

- [1] VON DER HARDT, P., TATTEGRAIN, A., " Phebus FP - An international severe accident research programme", International East-West Topical Meeting, Safety of Operating Nuclear Power Plants (TOPSAFE '95), Budapest, September 24-27, 1995.
- [2] SCHWARZ, M., JONES, A.V., "Analytical interpretation of FPT0 and preparation of future PHEBUS FP tests", *ibid.*
- [3] JAMOND, C., et al., "Phebus FPT0 test : Status of the interpretation of the bundle degradation using ICARE 2", IAEA Technical Committee Meeting on Behaviour of LWR Core Materials under Accident Conditions, Dimitrograd, Russia, October 9-13, 1995.