



RF CONTROL SYSTEM FOR THE KEK 40MEV PROTON LINAC

Z.IGARASHI, K.NANMO, T.TAKENAKA and E.TAKASAKI

National Laboratory for High Energy Physics, KEK

1-1 Oho, Tsukuba-shi, Ibaraki-ken, 305, Japan

Abstract

The KEK 40MeV proton linac comprises a pre-buncher, the first tank (750keV to 20MeV), the second tank (20MeV to 40MeV) and a de-buncher. As routine operation, negative hydrogen ion (H^-) beams of 5mA with a beam pulse duration of about 80 μ s are accelerated and transported to the Booster Synchrotron. In April, 1992, negative deuterium ion (D^-) beams of about 2.5mA were accelerated under the 4π -mode operation.

At present, in order to accelerate H^- or D^- beams, the accelerating field strength in each of the four cavities and the phase differences between the cavities are manually tuned by watching many beam monitors installed on the transport lines. Operation of the KEK 40MeV proton linac has therefore not been very easy. An RF control system with a feedback (ALC and PLL) system has thus been developed in order to stabilize the accelerating RF-fields and to deal with the acceleration mode, which would be used to select parameters of the accelerating field for the acceleration of various particle beams.

This report describes the RF-control system under development and the tested results.

Introduction

At the KEK-12GeV Proton Synchrotron (KEK-PS), under routine operation, proton beams are accelerated up to the 500MeV, with an average intensity of about $1.6\sim 1.7 \times 10^{12}$ pps, and then supplied to the Booster Synchrotron Utilization Facility. A proton beam accelerated up to an energy of 12GeV is transported to the Counter Halls for high-energy physics experiments. On the other hand, deuteron beams were successfully accelerated up to an energy of 11.2GeV on January 30th in 1992¹⁾. In April, 1992, the acceleration of deuteron beams were being carried out as routine operation. The 40MeV proton linac has thus supplied not only H^- beams of 5mA with a beam pulse duration of about 80 μ s but also D^- beams of about 2.5mA to the Booster Synchrotron as routine operation.

Recently, as one candidate future plan of the KEK-PS, a PS-collider, which is an accelerator machine used to accelerate and collide heavy ion beams, has been proposed²⁾. Therefore, in the future, the KEK 40MeV proton linac would accelerate not only H^- and D^- beams, but also heavy-

ion beams: For examples, polarized D^- beams, α -particles, carbon ions and so on. It is thus very important to reconstruct the RF-control system for ease of operation of the 40MeV proton linac.

Now, a new RF-control system has been designed to stabilize the accelerating field and to deal with the acceleration of various ion beams.

Present RF-System

After completing the linac upgrade to 40MeV, and then successfully operating the 40MeV proton linac,³⁾ some components of the RF-system have been improved. The two stage RCA 7651 amplifiers were replaced by a 10kW all solid state amplifier.

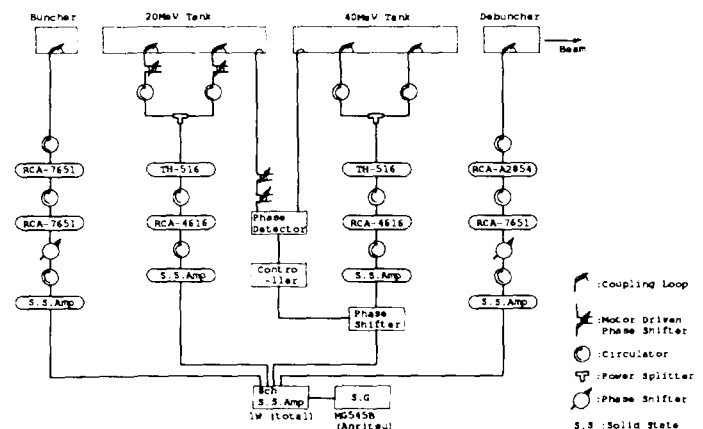

Fig.1 Block diagram of present RF system for the KEK 40MeV Proton Linac

Fig.1 shows a block diagram of the present RF-system for the 40MeV proton linac. As shown, the phase differences between the cavities have been tuned using a trombone phase shifter. The accelerating field strength has been manually controlled by tuning the anode voltage of TH516 at the final stage of the RF-amplifiers.

Beam Monitors, Tuning and Operation

The beam monitors installed on the transport lines have been used to adjust the phase and amplitude of the accelerating field in each of the cavities.

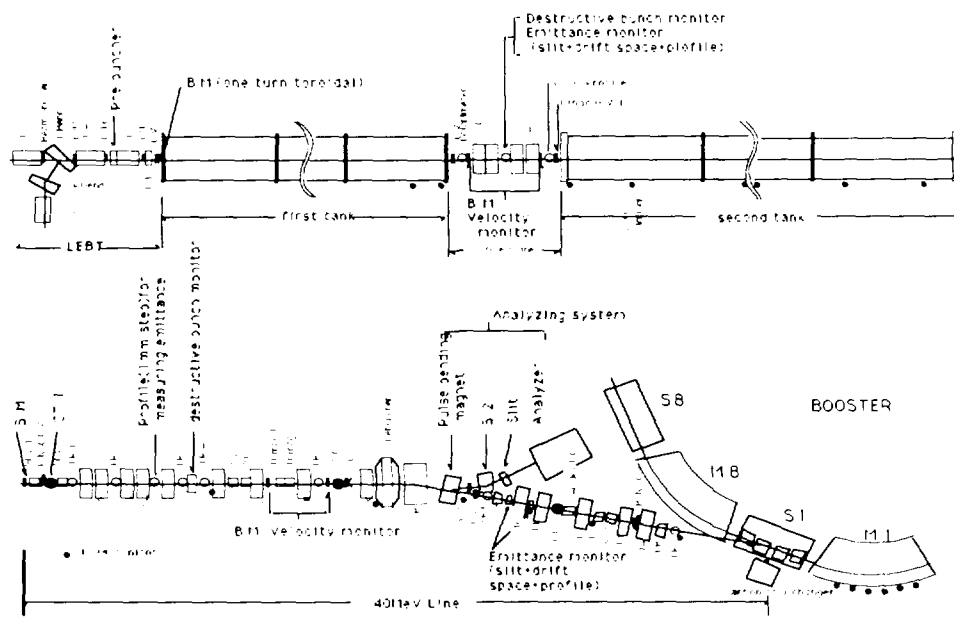

Fig.2 Layout of the KEK Proton Linac and the Beam Lines

Fig.2 shows the beam monitors in the 20 and 40MeV transport lines. Toroidal current monitors (CT), multiwire profile monitors (PR), destructive coaxial-type bunch monitors and a conventional magnetic analyzing system were installed. Recently, in addition to these monitors, nondestructive bunch monitors (one turn toroid with an amorphous core and pick-up electrodes), velocity monitors⁴⁾, a loss monitor system and the emittance monitors were designed and have been installed.

The energy of the center of beam bunches depends on the accelerating field in each tank as well as the phase difference between two tanks. At the beginning of routine operation, the variation of energy with the accelerating field strength and the phase difference has thus been measured with velocity monitors. The momentum of the 40MeV beam is strongly affected by the accelerating field. Since the momentum distribution is also very sensitive to the characteristics of the accelerating field, the momentum distribution has been measured using a conventional analyzing system. The usual momentum spread has been within $\pm 0.15\%$. Finally, the beam losses have been investigated using the loss monitor system installed around the proton linac and near to the transport lines.

Sometimes, to observe the microscopic beam bunches, the destructive coaxial-type bunch monitor was used. The bunch length was usually less than 72° . The capture efficiency of the second tank was measured with the phase differences between the first and second tanks. The acceptable phase width was about 40° under the normal accelerating field strength in the two tanks.

From our experience in tuning the KEK 40MeV proton linac, the characteristics of the 40MeV beam is very sensi-

tive to the phase differences and the accelerating field strength. Therefore, a phase-lock system (PLL) and an auto-level control (ALC) should be made and installed in the RF-system.

New RF-Control System and Test

A new RF-control system was designed in order that the RF-system can be easily controlled against the acceleration of various particles and the high-power RF-field supplied to the cavities with high stability and reliability. Fig.3 shows the designed RF-control system. This system comprises two loops (ALC and PLL) and mode-selector circuits. The ALC and PLL systems are useful for controlling the accelerating field strength and the pulse phase. The mode selector would be used to set up phase differences between the cavities. Therefore, in the future, some mode selectors will be combined with a big feedback loop to control the total RF-systems for the 40MeV proton linac. The 'mode select' will thus correspond to the requests against the acceleration of various particles, the beam intensity, the beam pulse duration and the beam velocity.

The ALC and PLL systems shown in Fig.3 were examined. In order to evaluate the ALC system, the accelerating field in the second tank was varied with the anode voltage of TH516 tube. Fig.4 shows the dependences of the accelerating field strength with or without the ALC system. As can be seen, the variation of the accelerating field was decreased to 1/10 by ALC. We also tried to accelerate an H⁻ beam with the ALC system. However, Beam loading effect was not completely cancelled using only the ALC because of the time lag of the accelerating field excited in the cavity

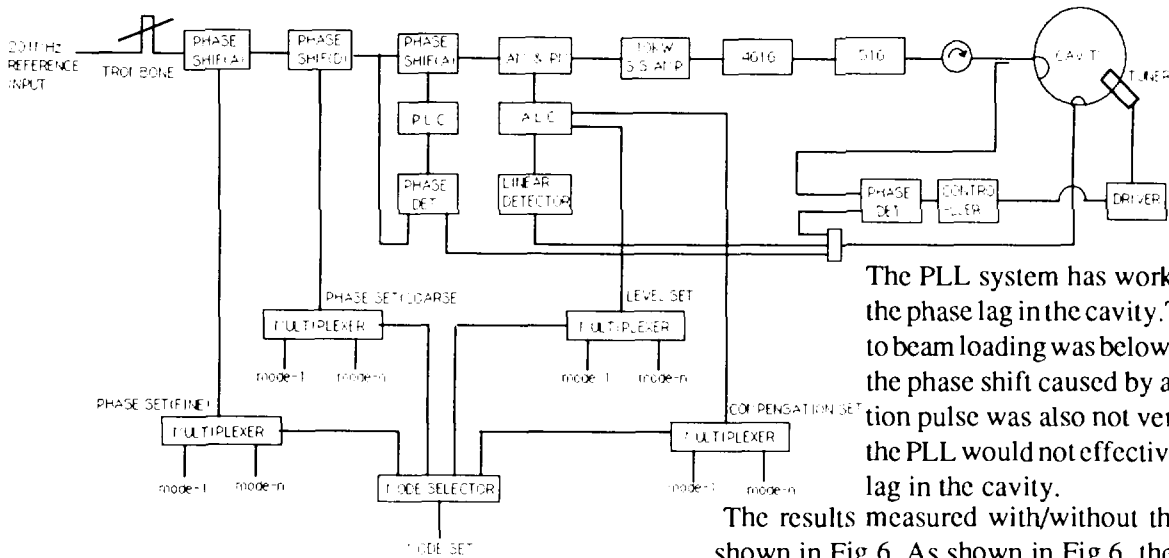

Fig.3 New RF-Control system

with a high Q-value of about 64000. Therefore, in addition to the ALC system, the RF-pulse for compensating the beam loading was applied in advance. The examined results are shown in Fig.5. As can be seen, the accelerating field was kept constant during the beam pulse duration.

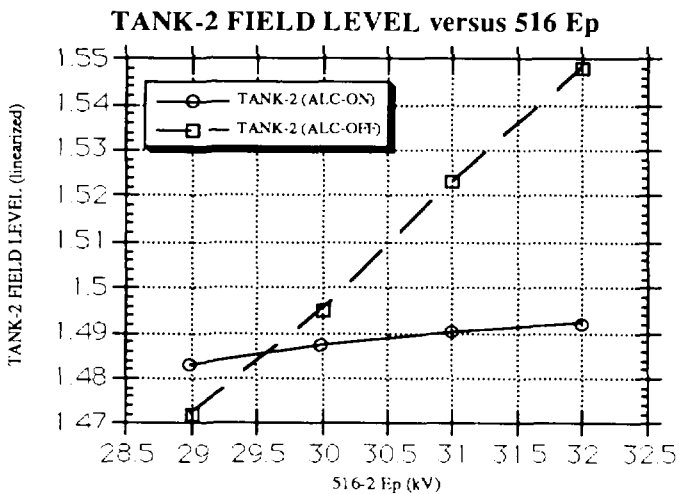

Fig.4 Evaluation of the ALC

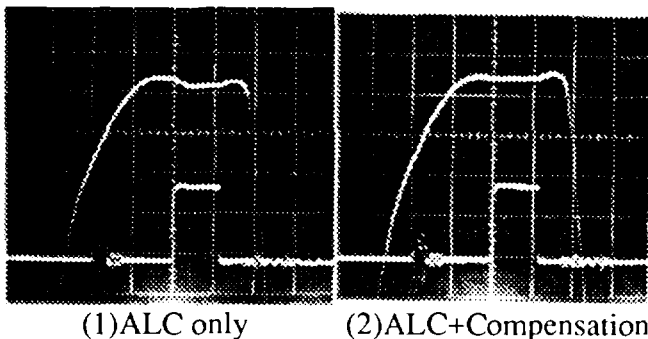
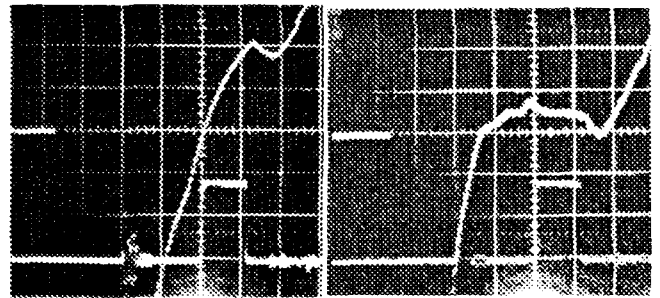

Fig.5 Tank field and pulse beam
upper : Tank field (6.7%/div)
lower : pulse beam (2mA/div)

The PLL system has worked well in spite of the phase lag in the cavity. The phase shift due to beam loading was below a few degrees⁵⁾ and the phase shift caused by an extra compensation pulse was also not very large. Therefore, the PLL would not effectively cause the phase lag in the cavity.

The results measured with/without the PLL system are shown in Fig.6. As shown in Fig.6, the phase shift in the pulse beam duration was decreased within 1° with the PLL system.

From these results it was concluded that the ALL and PLL systems operated well and that an extra compensation pulse against beam loading should be fed in advance. We are now trying to operate the RF-control system, including the big feedback loop, with the mode selectors.



(1) PLL off (2) PLL on
Fig.6 Effect of PLL
upper : phase (2.5deg/div)
lower : pulse beam (2mA/div)

References

- 1)Y.Mori et al.;The 8th Symp. on Accelerator Science and Technology, 1991, Saitama, Japan, p.7
- 2)PS-Collider design group; KEK report 90-13,1990
Y.Mori et al.; The 1991 IEEE Particle Accelerator Conference, San Francisco, 1991, KEK Preprint 91-57,1991
- 3)S.Fukumoto et al.; The 13th Inter. Conf. on High Energy Accel., 1986, NOVOSIBIRSK, p.293
S.Fukumoto, et al.; Proc. of the 1986 Linear Accel. Conf., SLAC, p116
- 4)Z.Igarashi and E.Takasaki; submitted to this Proceedings.
- 5)T.Kato and E.Takasaki; IEEE Trans. Nucl. Sci., NS-28, No.3, 3507, 1981