

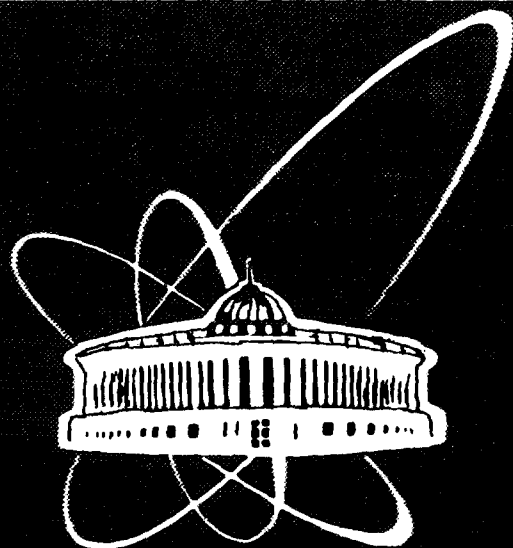

XJ9700218



СООБЩЕНИЯ
ОБЪЕДИНЕННОГО
ИНСТИТУТА
ЯДЕРНЫХ
ИССЛЕДОВАНИЙ

Дубна

E13-97-22
ATLAS Internal Note
TILE-CAL-NO-90

Yu.
J. Budagov, Yu. Kulchitsky*, A. Lebedev, Yu. Lomakin,
V. Romanov, N. Russakovich, A. Shchelchkov,
A. Sissakian, J. Sorokina, N. Topilin

SOME AUXILIARY TECHNOLOGY EQUIPMENT
FOR ATLAS HADRON CALORIMETER MODULE
AND SUBMODULE MANIPULATIONS
AND THE QUALITY CONTROL
OF THE ASSEMBLED MODULE

*On leave from IP Academy of Science, Minsk, Belarus

1997

1 THE INCOMING INSPECTION OF THE GIRDER FOR MODULE-0

Following the distributions of the obligations among MODULE-0 producers the girder for the MODULE was manufactured by the FORT-PRESS-plant (the CLUJ-city, Romania). After the girder arriving to Dubna on the MODULE-0 assembly shop-area, the girder has been observed visually to check if the mechanic damages are absent. By the universal measuring tool the main geometry dimensions of the girder have been measured; these are:

- the length of the girder;
- the width of the girder's key projection (in a few points along the girder length);
- the height of the girder's key projection;
- the distance between the connecting thread holes;
- all other basic outside girder's dimensions.

All the controlled geometric girder's dimensions did fit by shop-drawings figures.

The significant practical interest was also connected with

- a) the flatness and the horizontality in positioning of the surface of the girder's key projection for mounting of submodules and
- b) the twisted angle of flat surface along the girder length.

To carry out the listed measurements the girder has been put on the uniformly distributed — along the girder's length — supports of MODULE-0 assembly main tool. The deviations of the girder's key projection plane from the horizontality were measured in the region supports by the mini-level in two directions:

- in longitudinal (see Fig. 1a);
- in transversal (see Fig. 2a).

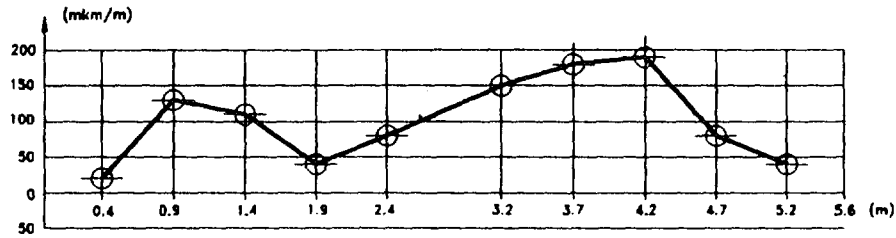

Fig. 1a

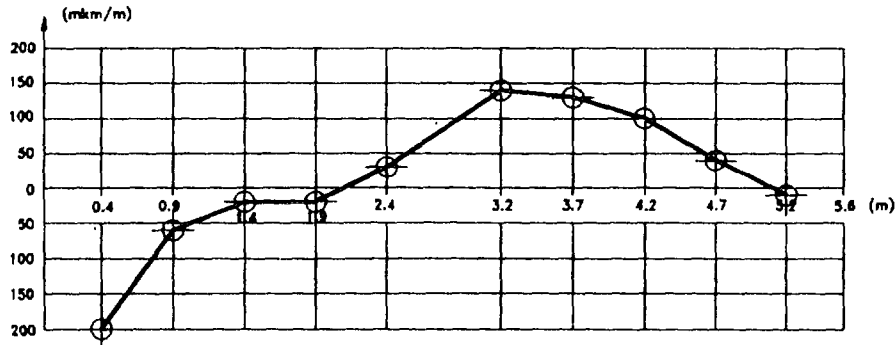

Fig. 1b

Figure 1: a) The measurement results of the horizontal positioning of the surface of girder's key projection. The girder is freely laying on the support; measurements are done in the longitudinal direction. b) The same after the girder's positioning was corrected.

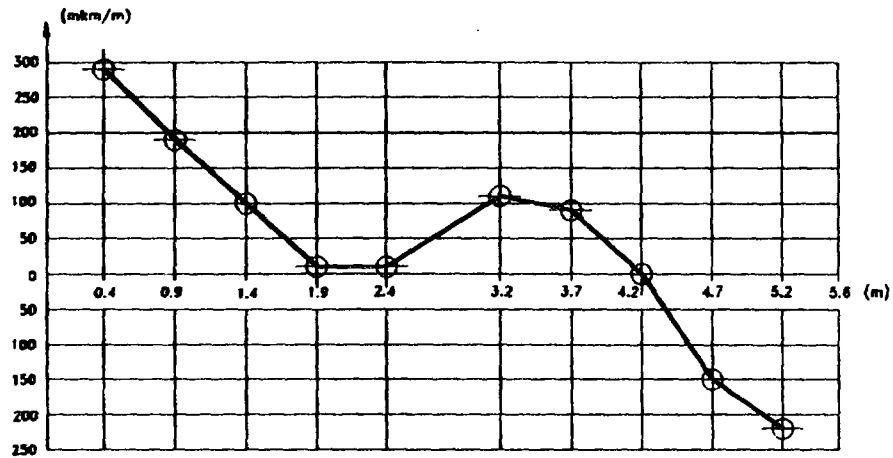

Fig. 2a

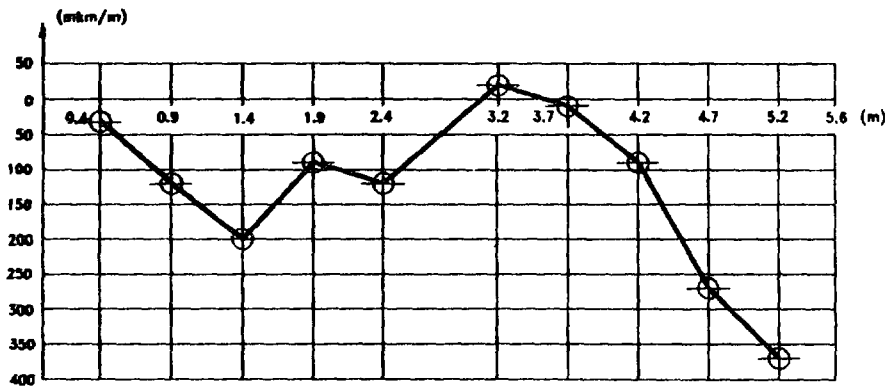

Fig. 2b

Figure 2: a) The measurements results of the horizontal positioning of the surface of girder's key projection. The girder is freely laying on the support; measurement are done in the transversal direction. b) The same after the girder's positioning was corrected.

The measurement precision was $10 \mu\text{m}$ per 1 meter length. As the measurement had demonstrated the presence of the common slope of the girder in its longitudinal direction (see Fig. 1a) therefore between the edge support and the girder's down end side some shims of 1.1 mm and of 1.26 mm thickness were inserted. In the gaps appeared between the girder and the remaining supports of the main tool for MODULE assembly the necessary thickness shims were positioned. After that the girder was pressed by clamps to the supports the measurements of deviations from the horizontal plane of the girder's key projection were repeated. These measurements were carried on the same (as before) points and two directions:

- in longitudinal (see Fig. 1b),
- in transversal (see Fig. 2b)

The repeated measurements indicated that the girder has occupied the position close to the absolute horizontality of the surface of the girder's key projection. Important to stress that the girder was not subjected to significant deformations caused by clamps influence.

Due to absence of the complete set of measuring instruments and because of the lack of time the girder's side sagita (the circle like shaping) was not measured. However: the 2 m long range ruler did not demonstrate any gaps between that ruler and the girder's side surface.

1.1 Conclusions

1. Both the measurements undertaken and the consequent MODULE-0 assembly have demonstrated the good quality of the girder manufacturing.
2. Before the girder mass production start one needs to develop the dimensions measurement program to determine the amount of measurements to be done and purchase the lacking measurement instruments.

2 SUBMODULE MANIPULATION TOOL (auxiliary technology equipment)

2.1 General demands

The submodule manipulation tooling must be simple in production, convenient and save in use.

The submodules are the module components. During all the technological process of submodules manufacturing, of their inter shop-areas transporting and installing on the girder when module assembly the universal rigging tools as well as specially designed and constructed ones are used.

In this article we describe the design and the using rules of the special rigging tools for manipulations of submodules. All the below described tools have been designed and constructed in the Laboratory of Nuclear Problems (LNP) of the JINR (Dubna). When designing of some parts of the tooling we have taken into account the experience of the use of the such sort of instruments at CERN.

2.2 Design description. How to use the special rigging tools for the manipulations with submodules.

The submodules manufacturing technological circle determines the necessity of the submodules transportation in the following cases:

- A. The glued submodules lifting over the table (for gluing) on about $10 \div 15$ cm;
- B. The submodules horizontal transportation to the weld shop-area;
- C. The submodules transportation between different shop-areas or/and institutions;
- D. The submodules painting;
- E. The submodules rolling over when moving from horizontal position to the vertical one;
- F. The submodules mounting on the girder.

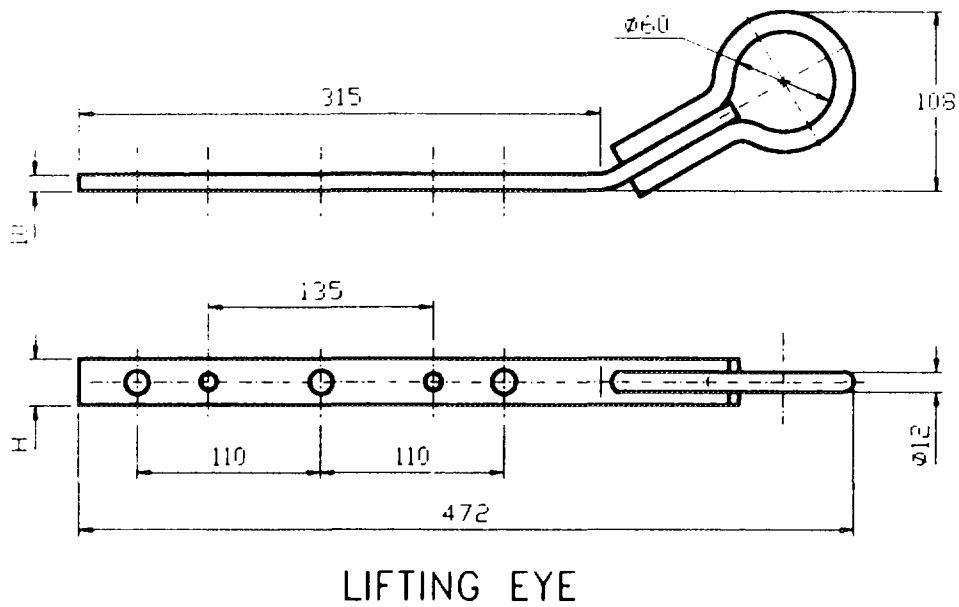

Figure 3

The A-case. After the epoxy glue polymerization is completed the strips must be welded on the submodule's corners. The preliminary strips spot-weld is done on the table for gluing and the final weld (with continuous seam) — on welding shop-area.

After the strips spot pre-welding on the submodule corners the liftin eyes (four of them) are joined by bolts to the strips (see Fig. 3).

The lifting eyes consist of the plates (with holes necessary to join the lifting eyes to the submodule's strips) and of the welded eye (pos. 2) to capture the submodule by the slings of the crane.

In the submodule narrow part the lifting eyes are joined by *M12* bolts and in the wide part — by the *M16* bolts. The submodule slinging scheme is given on Fig. 4).

With the help of such lifting eyes the submodule can be lifted over the table on $10 \div 15$ cm height.

The B-case. To bring the submodule on the welding shop-area two structural channels are laid under the submodule and then the submodule with the help of standard slings is transferred to the welding place. This transporting method is a quite universal one when moving the long object and is not considered in this case.

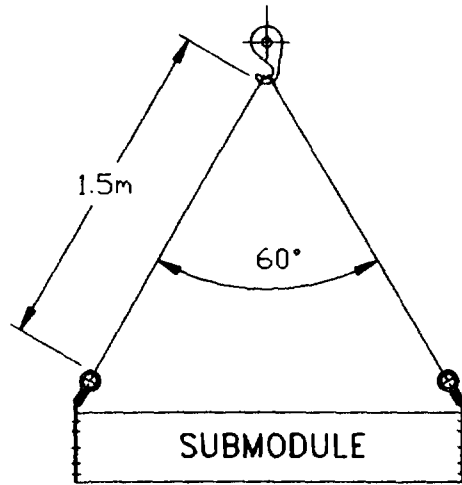

Scheme of submodule slinging
with using of lifting eyes

Figure 4

The C-case. When inter shop-areas (or between the Institutions) submodule transportation the submodules with the help of the lifting eyes (see Fig. 3) are positioned on the wooden supports and if it is necessary — connected to them. The wooden supports together with submodules are lifted by crane or accumulator car.

The D-case. The submodules painting is done by the dip method. When painting the scintillator's slots must be kept vertical. For this purpose the special cross-rail is serving (see Fig. 5).

The cross-rail is a rigid-welded frame (pos. 1, Fig. 5) with two freely-rotating brackets (pos. 2 and 3, Fig. 5) to join the submodules on their edges. The frame has two eyes to take the cross-rail by slings of crane.

For the submodule painting the cross-rail's brackets are joined to the submodule edges. After the submodule is lifted with the cross-rail it can be easily — by hands — rotated around the longitudinal axis.

After the paint full drying the submodule is transferred to the horizontal position or — with the same cross-rail help — brought to the rolling over tool.

The E-case. For the convenience of the scintillators slots visual inspection and also for the submodule mounting on the girder when module

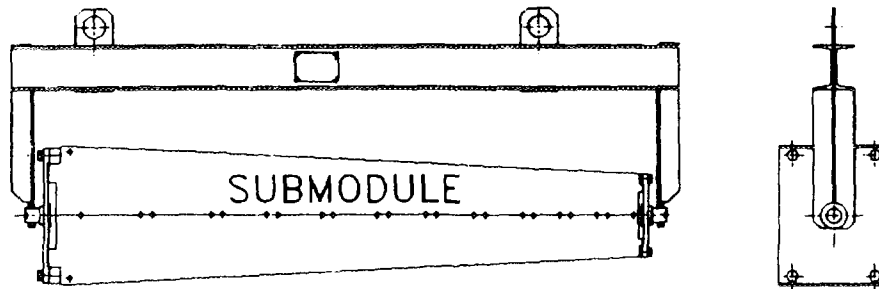

Crossrail

Figure 5

assembling one needs to have the submodule staying vertically on its wide end.

To transfer the submodule from horizontal position to vertical one the rolling over tools are used (see Fig. 6).

The rolling tool consists of:

- the stationary bracket (pos. 1, Fig. 6);
- the movable bracket (pos. 2, Fig. 6);
- the lock pin (pos. 3, Fig. 6);
- the bracket for lifting (pos. 4, Fig. 6).

In order to transfer the submodule to the horizontal position the sub-module with help of lifting eyes (Fig. 3) or the cross-rail (Fig. 5) is being brought to the rolling over tool (Fig. 6) and laid down on two wooden bars. The lifting eyes (of the cross-rail) are disconnected. The submodule's wide end by four *M16* bolts is joined to the movable bracket (pos. 2) of the rolling over tool. The brackets for lifting are connected to the submodule's narrow end with six *M12* stud bolts (pos. 4).

The slings are joined to the bracket and by the crane, slowly, the sub-module is transferred to its vertical position. When the last position is

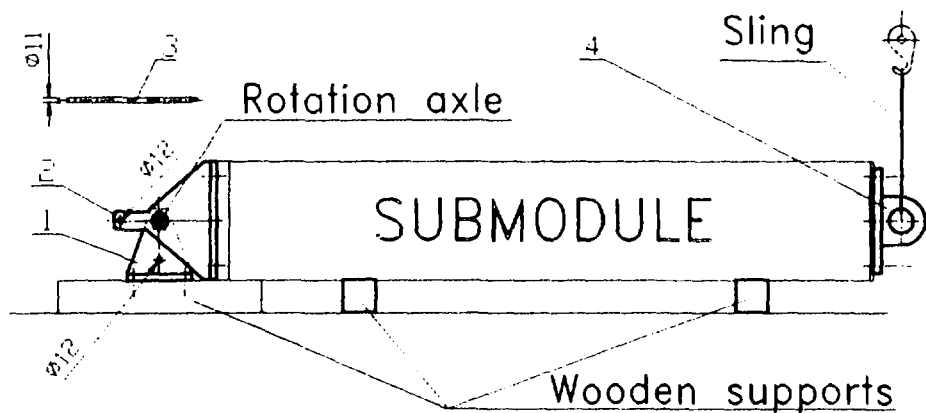

Figure 6

reached the movable bracket (pos. 2) is fixed relative to the stationary bracket (pos. 1) by the lock pin (pos. 3).

After that the *M16* bolts are disconnected submodule is positioned vertically on the stiffened base or on the girder, — if the module assembly is processing.

One has to pay the special attention: before the M16 bolts disconnection it is necessary to be convinced that both movable stationary brackets ARE connected between themselves by the lock-pin and — additionally — that stationary bracket is in the contact with the floor.

These conditions observing are a demandingly necessary safety step to prevent the traumas of the personnel working with submodules.

The F-case. The submodule mounting on the girder when module assembling is executed with the help of lifting bracket (pos. 4, Fig. 6) after the completion of the operations described in “The E-case”.

If necessary the submodule dismounting is executed with the same lifting bracket.

2.3 The strength

All the above described submodule manipulation tools contain the welding seams. The type and the dimensions of the welding seams have been chosen on the base of the experience of the similar object design and practical

use. Also the inverse design of welding seams strength has been done. The maximal stress in the most loaded welding seams reach up to 30% of the allowed ones. The calculation was based on the methods of Material Strength. Besides that all rigging tools were tested following the country-producer norms and roles.

2.4 The production and application experience of the special rigging tools for the manipulations with submodule.

All the above described tools have been manufactured and used when MODULE-0 production.

Here we would like to mention one following positive features of these tools:

- the production simplicity;
- the small amount of the used materials;
- cheapness;
- the use of the thread holes — already existing on the assembled submodule — for connecting of the rigging elements.

As a negative features one can mention the necessity of the special care, large punctuality when connecting the rigging tools to the submodule. The additional punctuality is an obligatory measure to prevent the distortion of the submodule strip thread holes.

2.5 Conclusion

As whole the experience of the special rigging tooling application when manipulating with the submodules has demonstrated the correctness of the conceptual ideas used for these tooling designings. And from the point of view of current time one finds no need in the existing tooling modification. If however it will become necessary to manufacture the tooling one again, on the new place (Institution) there are possible some modifications of the elements used depending on the practically accessible for the producer the variety of materials.

3 MODULE CONTROL MEASUREMENTS

After module assembled it is necessary to determine the non-flatness of module's side walls. This parameter is affected by:

- A. Straightness of the girder,
- B. Master plates manufacturing precision,
- C. ϕ -angle precision of the submodule mounting,
- D. Strips deformation degree in the submodules narrow part after welding.

The most significant contributions to the module side surfaces non-flatness are the A and C factors.

Factor A depends on the original girder precision, on the girder transportation and storage conditions, on the possible girder deformations due to internal stresses in the weld seams when long term girder storage.

The girder straightness control is a necessary one both after the girder manufactured and immediately before the module assembly.

The C-factor influence could be decreased by module assembly quality improving.

The B-factor influence is non-significant provided all the master plates were manufactured using the same technology: either blanking die or by laser cutting.

The D-factor could be kept minimal with appropriate strips welding technology.

Having in mind the above mentioned it would be sufficient to make the judgement on the module side surfaces non-flatness by the measuring of the girder straightness before the module assembly and also by the measuring of the straightness of the surface made by the strips side surfaces in the module narrow part after module assembled.

To produce these measurements it is the most efficient to use strained string together with reading-off microscope. This method allows one to check the straightness of surfaces located in the horizontal or vertical planes.

The string (grand-piano wire) must have constant cross-section along all its length; the string's bends must be excluded. The wire is straightened by some load which weight is enough to obtain (in the extreme points of

surface) the equal distances between the string and the checking surface. The wire diameter for module measurements is 0.08 mm.

By moving of the stand with microscope one must have the eyepiece micrometer thread image coincided with wire image; after that one determines (using the micrometer trimble) the values of the deviations of the surface from the straightness.

The base of the stand could be flat, of V-form or some other one correspondingly to the checked surface profile.

The using of this measurement method is possible on module assembly area (building # 5, Laboratory of Nuclear Problems, JINR, Dubna or/and at CERN without special additional measures).

The total measurement of module (girder) on 3 coordinates needs to have:

A: the specially aided floor of about $1.5 \times 6 \text{ m}^2$;

B: the set of measurement means:

- high precision level theodolite,
- high precision universal electronic theodolite,
- surveyor's staff (special product);

C: the reference marks available on the module and girder;

D: the well qualified personnel.

The technology of module (girder) side surface non-flatness measurements is:

- * module (girder) is mounted on the special floor;
- * theodolite is positioned on the reference marks;
- * with the theodolite help we mount the markers on the floor at 90 degrees to module (girder) longitudinal axis (Fig. 7);
- * move the theodolite on the marker;
- * with the surveyor's staff help we measure the distance to the module (girder) along all the length of module (girder) (Fig. 8).

As the theodolite positioning precision is comparable with the measurements accuracy one needs to carry out a few measurements for one module or girder.

We thank S.Ignatov for help and consultations.

4 SUPPORT DESIGN DESCRIPTION FOR 0-MODULE TRANSPORTATION

4.1 Introduction

Module-0 has a shape of the trust-rum wedge 5640 *mm* long, 1950 *mm* height and about 400 *mm* wide for the wide part and 225 *mm* for the narrow part of the wedge. In the wide part the girder is situated. This girder is strong and stiff. The girder permits to install the module in its vertical position on two supports (Fig. 9).

In the wedge narrow part there are no strong enough elements. The strength and stiffness of the front plate in the narrow part of the wedge doesn't permit to put the module in the horizontal position on the localised supports. This is why the module transportation options were mainly the vertical ones. Such variant looked originally very expedient however when the practical realization had started one faced new technical problems and old ones became sharper:

- the high position of the module centre of gravity;
- the necessity to redistribute the concentrated forces from the module weight ($\approx 20 t$) to power elements of the truck box;
- the necessity to fix the module by the side tension bars;
- the impossibility to attach this tension bars to the truck platform, as the truck platform deformation would have been transmitted to the module. This is inadmissible;
- the necessity to have the truck with the box internal height about 2.5–2.8 *m*;
- the necessity to have the high ceiling Machine Shop to load the module and to unload it (about 7 meters from the floor to the crane hook);

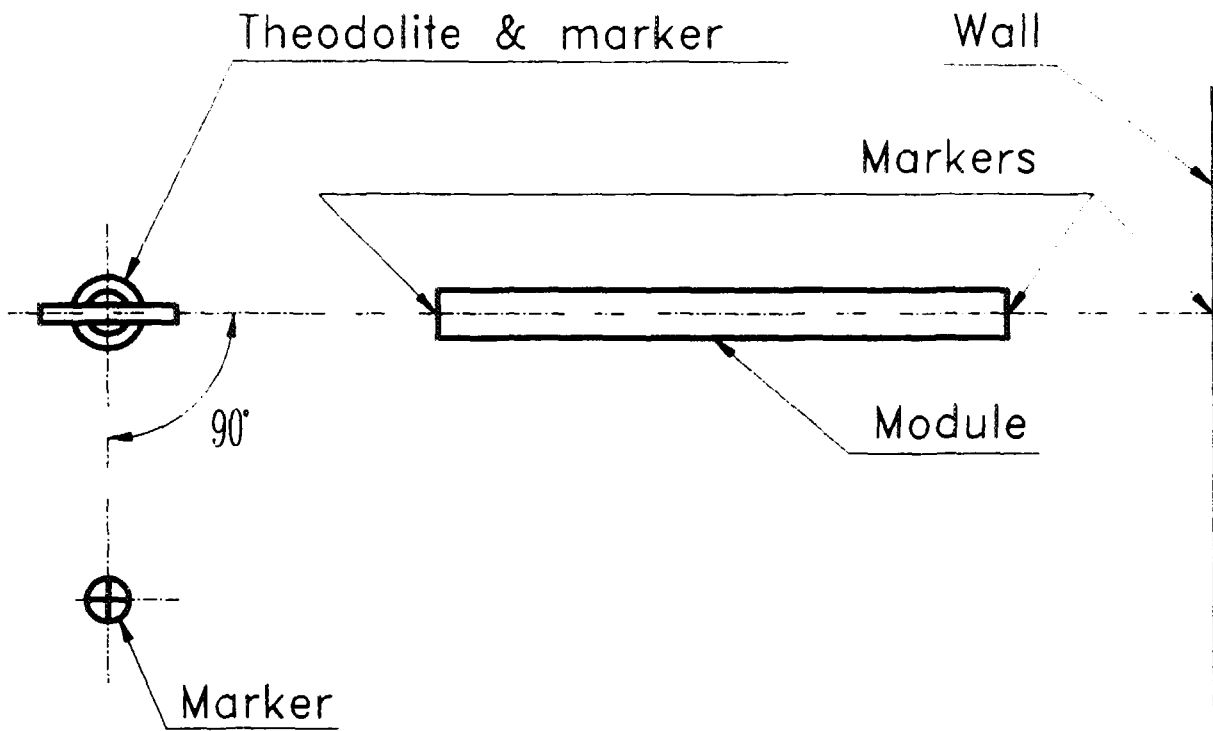

Figure 7

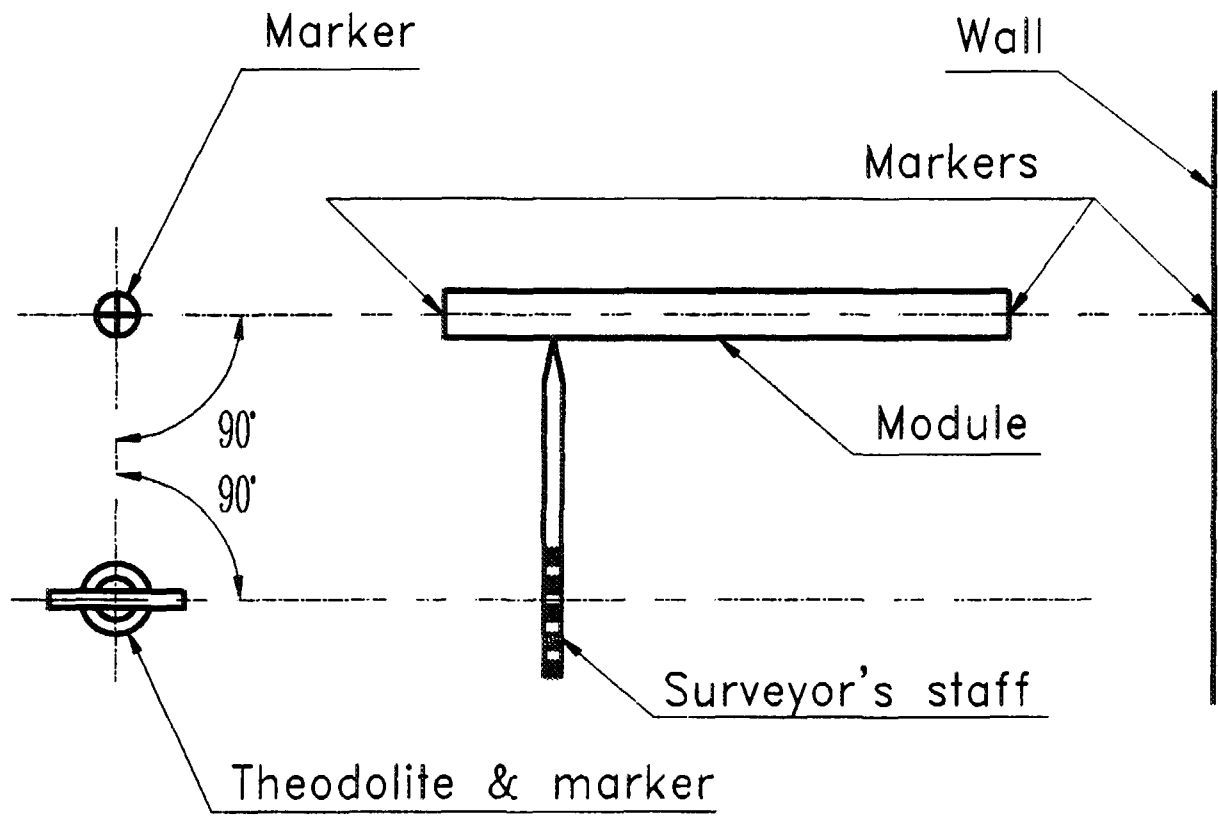

Figure 8

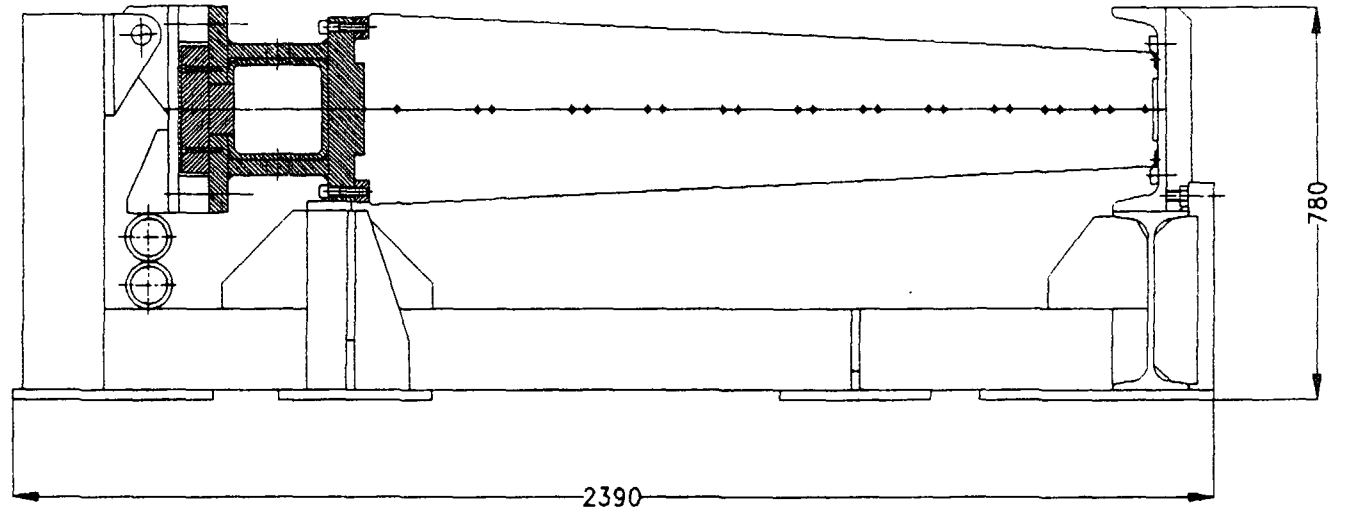

Figure 9

The module0 on the transportation support

JINR has the D-641 type semi-trailer of the “ZASLAV” firm; this track was used for the 0-module transportation from Dubna to CERN (Site de Prevezin). The internal dimensions of the semi-trailer body are:

- length – 12500 *mm*;
- width – 2410 *mm*;
- height – 2200 *mm*.

The maximum load for that semi-trailer is 25 *t*. Using these data we examined the case and realized the module transportation option in the horizontal position.

4.2 The support design description for the 0-module transportation

Before the designing of the module transportation support the support for transferring of the module from the vertical position to the horizontal one was fabricated following to the V. Romanov’s drawings. As this support had to be delivered to CERN it was decided to adapt that ready construction for the module transportation by truck.

The base conception of the support design for the module transportation is the idea of module reclining upon three points. If following to such module reclining scheme the module original form is conserved. The semi-trailer platform deformation would not be transferred to the module when the truck is moving.

The problem was to find these three points. As a results when the module was transportated it was reclined on the line in the narrow part of the wedge and on the point of the girder middle. The stiffness in the narrow part of the wedge was significantly enlarged. For that the structural channel (# 40, $J = 15220 \text{ cm}^4$) was fixed to the module by 114 studs. The structural channel was leaned along all its 5700 *mm* length on the *I*-beam (#36, $J = 13380 \text{ cm}^4$) and was welded to it with the help of six 50×100 *mm* plates. The *I*-beam with the help of the ribs was welded to the existing support. In the middle part of the support base the centre support for the module girder was created. To protect the girder surface this support was covered by the copper sheet.

In such a position the deflection of the girder ends (as static case) is 1.3 mm and the stress is 300 kg/cm². These stresses are significantly less than the proportional limit (1600 kg/cm²).

To damp the elastic vibrations when the truck with the module is moving the girder's ends were reclined on the dampers. The dampers are two cylinder rings (cut from the tube) welded between themselves. The rings have the plastic deformation at about 400 kg force (which is necessary small).

4.3 The successive fulfilment of the operation when 0-module is installed to the semi-trailer for the transportation to CERN

1. To install the support (draw.#2839-00-00) on the specially prepared (steel) floor. It is necessary to foresee suitable free spaces (1.5–2.0 m gaps) from the building walls or the other objects.
2. To set up on the narrow part of the module the beam (draw. # 2813-16-00) and 18 brackets for module lifting by the traverse.
3. To lift the module with help of the traverse and to put it on two supports in such a way which allows to set up two brackets onto the girder.
4. To move the module with the mounted brackets to the support in such manner which allows to insert the axles to the holes of the girder brackets and of support's ones.
5. To transfer the module from the vertical position to the horizontal one. To connect the beam (draw. # 2813-16-00) with the support by welding (or M16 bolts). To disconnect the traverse.
6. To set up the angle brackets on the girder. To connect the traverse.
7. To put the module together with the support in the semi-trailer.
8. To lift slightly the module, to remove the axles connecting the girder with the support.
9. To lift down the module on the support. To disconnect the traverse. To take off the angle brackets.

10. To weld 6 sheets connecting the beam (draw. # 2813-16-00) with the support.
11. To cover the module by the polyethylene film.
12. In the accessible places it is necessary to fasten the 80×80 mm rectangular wooden bars to the semi-trailer floor to prevent displacements of the support in two orthogonal directions when the truck is moving.
13. To forbid to transport the module on the hill roads.
14. The maximum velocity of the moving:
 - on the roads of Russia, CIS, Poland — 50 *km/hour*;
 - on the roads of Germany, France — 60 *km/hour*.

Received by Publishing Department
on January 28, 1997.

**SUBJECT CATEGORIES
OF THE JINR PUBLICATIONS**

Index	Subject
1.	High energy experimental physics
2.	High energy theoretical physics
3.	Low energy experimental physics
4.	Low energy theoretical physics
5.	Mathematics
6.	Nuclear spectroscopy and radiochemistry
7.	Heavy ion physics
8.	Cryogenics
9.	Accelerators
10.	Automatization of data processing
11.	Computing mathematics and technique
12.	Chemistry
13.	Experimental techniques and methods
14.	Solid state physics. Liquids
15.	Experimental physics of nuclear reactions at low energies
16.	Health physics. Shieldings
17.	Theory of condensed matter
18.	Applied researches
19.	Biophysics

Будагов Ю.А. и др.

E13-97-22

Некоторое вспомогательное технологическое оборудование для манипуляций с submodule при сборке модуля адронного калориметра установки АТЛАС

Представлено описание вспомогательного технологического оборудования для манипуляций с submodule и модулем. Приведены результаты входного контроля балки для модуля-0. Описаны варианты контрольных измерений готового модуля. Представлено описание конструкции для его транспортировки.

Работа выполнена в Лаборатории ядерных проблем ОИЯИ.

Сообщение Объединенного института ядерных исследований. Дубна, 1997

Budagov J.A. et al.

E13-97-22

Some Auxiliary Technology Equipment for ATLAS Hadron Calorimeter Module and Submodule Manipulations and the Quality Control of the Assembled Module

Describing of the auxiliary technology equipment for the submodule and module manipulations is presented. The results of the 0-module beam incoming control is given. The variations of the assembled module control measurements are described. The description of the construction for the 0-module transportation is presented.

The investigation has been performed at the Laboratory of Nuclear Problems, JINR.

Communication of the Joint Institute for Nuclear Research. Dubna, 1997

Макет Т.Е.Попеко

Подписано в печать 27.02.97
Формат 60 × 90/16. Офсетная печать. Уч.-изд.листов 2,01
Тираж 370. Заказ 49758. Цена 2412 р.

Издательский отдел Объединенного института ядерных исследований
Дубна Московской области