

92590A

ANL/ASD/CP-92590

A beryllium window for an APS diagnostics beamline

M97054053

CONF-910706--

I. C. Sheng, B. X. Yang, S. Sharma

RECEIVED

Argonne National Laboratory, Advanced Photon Source,
9700 South Cass Ave., Argonne, IL 60439-4815

AUG 22 1997

OSTI

ABSTRACT

A beryllium (Be) window for an Advanced Photon Source (APS) diagnostics beamline has been designed and built. The window, which has a double concave axisymmetrical profile with a thickness of 0.5 mm at the center, receives $160 \frac{W}{mm^2}$ (7 GeV/100 mA stored beam) from an undulator beam. The window design as well as thermal and thermomechanical analyses, including thermal buckling of the Be window, are presented.

Keywords: Beryllium, window, brazing, thermomechanical, APS, diagnostics, thermal, buckling, closed form solutions, finite element method.

1. INTRODUCTION

In order to maintain the vacuum integrity of the APS storage, windows are required to separate the beamlines from the ring. The window discussed in this paper is installed in the diagnostics undulator beamline where the normal incident beam power is $160 \frac{W}{mm^2}$, and the total incident power (7 GeV, 100 mA positron beam) is 800 W. The window satisfies the following design criteria:

- reduced absorption of x-ray power
- enhanced cooling to reduce the temperature gradient
- ability to withstand vacuum force in case of leak in the beamline
- large window stiffness to increase thermal buckling threshold
- passively safe during beam missteering
- ease of fabrication

2. DESIGN FEATURES

Beryllium is used for the window material because Be has low x-ray absorption coefficients and high material strength. As shown in Figure 1, a double concave window is introduced. This geometry is chosen as a compromise between two contradictory effects of window thickness:

- thicker windows increase the thermal conduction as well as the flexural stiffness
- thinner windows reduce absorbed power

The center of the Be window is 0.5 mm thick, which allows Be to absorb only 5% of the 800 Watts total power of the diagnostic undulator beam at 100 mA, with a beam size of 2 mm. This double concave Be window has three advantages: 1) it absorbs less power when beam is at its normal position; 2) it provides a larger conductive area for heat flow; and 3) it is structurally stiff, which prevents thermal buckling.

DISTRIBUTION OF THIS DOCUMENT IS UNLIMITED

MASTER

DISCLAIMER

This report was prepared as an account of work sponsored by an agency of the United States Government. Neither the United States Government nor any agency thereof, nor any of their employees, makes any warranty, express or implied, or assumes any legal liability or responsibility for the accuracy, completeness, or usefulness of any information, apparatus, product, or process disclosed, or represents that its use would not infringe privately owned rights. Reference herein to any specific commercial product, process, or service by trade name, trademark, manufacturer, or otherwise does not necessarily constitute or imply its endorsement, recommendation, or favoring by the United States Government or any agency thereof. The views and opinions of authors expressed herein do not necessarily state or reflect those of the United States Government or any agency thereof.

DISCLAIMER

Portions of this document may be illegible electronic image products. Images are produced from the best available original document.

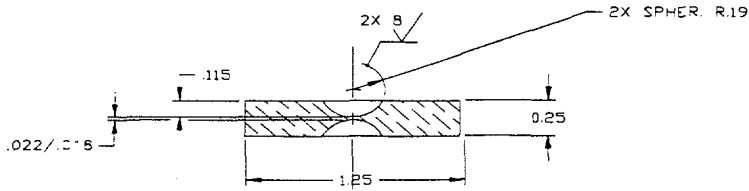

Figure 1. Cross Section of the Double Concave Be Window (dimensions are in inches)

This geometry significantly increases the thermal conduction and flexural stiffness without increasing the power absorption. As shown in Figure 2, the Be window, made of 99.4% pure beryllium, is diffusion brazed on the counterbores of a water-cooled oxygen-free high-conductivity (OFHC) copper manifold. Two 304 stainless steel tubes are brazed on both ends of the manifold and then welded onto 8" flanges. The Brush Wellman Company made this particular brazed assembly.

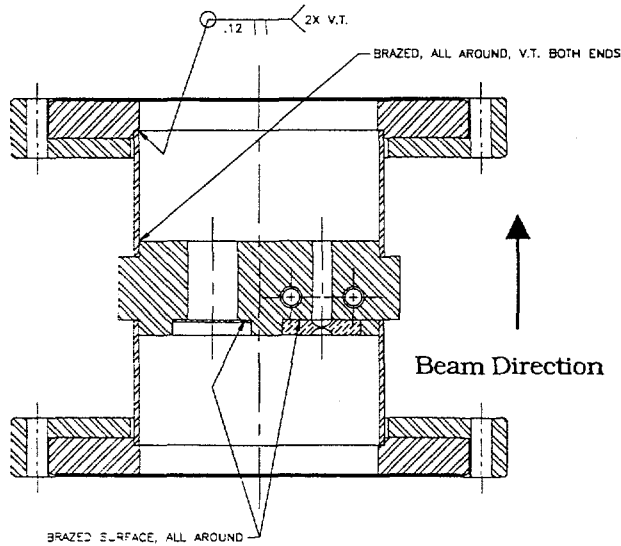

Figure 2. Cross Section View of the Be Window Assembly

3. THERMAL ANALYSIS

As the Be window absorbs the x-ray power, temperature gradients are generated across the material. The resulting thermal stresses can cause the window to buckle and fracture. Thus the temperature rise within the Be window is the primary parameter to be determined. Let t (Figure 3) represent the thickness at the center, and r_o , L , b , r_1 , and a denote the spherical radius of the concave area, thickness, the edge where the concave surface ends, beam size radius, and the radius of the Be window, respectively.

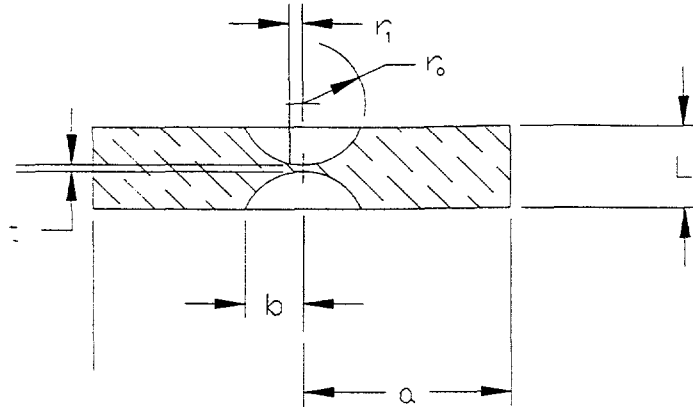

Figure 3. Geometric Dimensions of the Double Concave Be Window

The calculation of the peak temperature rise at the center can be divided into three parts: 1) the temperature rise (ΔT_1) within the area where the window intercepts the x-ray power; 2) the temperature rise (ΔT_2) within the concave area but excluding the area in part 1; and 3) the temperature rise (ΔT_3) outside the radius r_o . Since the beam size is small as compared to the spherical radius, it is reasonable to treat the region in part 1 as a volumetric heating of a thin disk with constant thickness r_1 . Using Fourier's law¹, the temperature rise ΔT_1 can be expressed as

$$\Delta T_1 = \frac{q}{4 \pi k t} \quad (1)$$

ΔT_2 is given as

$$\Delta T_2 = \frac{q}{2 \pi k} \int_0^b \frac{dr}{r \left(r_o + \frac{\delta}{2} - \sqrt{r_o^2 - r^2} \right)} \quad (2)$$

where q is the total power intercepted (40 W), and δ is the window thickness when the radius is r_1 and is expressed as

$$\delta = 2 \left[\left(r_o + \frac{t}{2} \right) - \sqrt{r_o^2 - r_1^2} \right] \quad (3)$$

The temperature rise ΔT_3 is given by

$$\Delta T_3 = \frac{q}{2 \pi k L} \ln \left(\frac{a}{b} \right) \quad (4)$$

The total peak temperature ΔT rise at the center of the window is the sum of these three temperature contributions:

$$\Delta T_1 + \Delta T_2 + \Delta T_3 = \frac{q}{4 \pi k t} + \frac{q}{2 \pi k} \int_0^b \frac{dr}{r \left(r_o + \frac{\delta}{2} - \sqrt{r_o^2 - r^2} \right)} + \frac{q}{2 \pi k L} \ln \left(\frac{a}{b} \right) \quad (5)$$

The second integral can be solved numerically. With the thermal conductivity of Be $k = 1.6 \frac{W}{cm \cdot K}$ [†] and total power $q = 40$ W, we obtain a total temperature rise of 86 °C. The temperature contours analyzed by the finite element method (FEM) shown in Figure 4 predicts a maximum temperature rise of approximately 61 °C :

[†] Material constants can be found at <http://aries.ucsd.edu/PROPERTIES/be.html>.

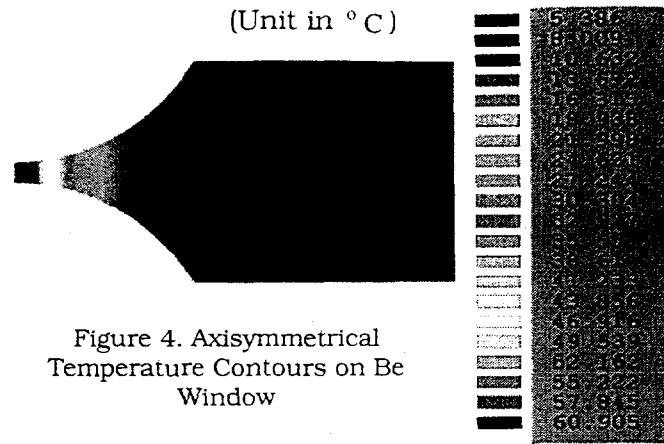

The closed form and FEM results differ to some extent because in the latter model the brazing joint is on one side of the Be window surface rather than on the periphery of the window. This brazing feature not only shortens the heat resistance path but also increases the mechanical stiffness.

A parametric study is also presented in Figure 5. The peak temperature contours plot versus spherical radius and central thickness of the window show that the current design indeed optimizes the temperature rise.

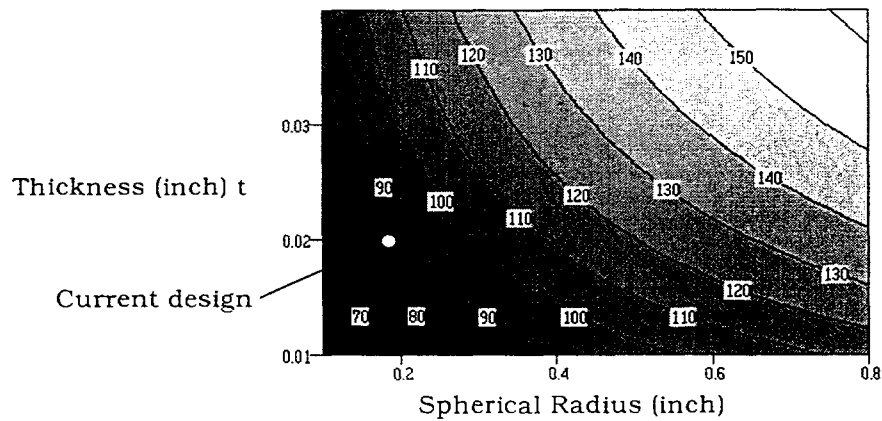

Figure 5. Maximum Temperature Contours Plot with Changing of Thickness and Spherical Radius

Retaining the same thickness (0.5 mm), we also calculate the temperature rise of a thin Be window with 1.25" diameter. The temperature rise ΔT is expressed as

$$\Delta T = \Delta T_1 + \Delta T_3 = \frac{q}{4\pi k t} + \frac{q}{2\pi k t} \ln\left(\frac{a}{r_1}\right), \quad (6)$$

which yields a temperature rise of 173 °C at the center of the window. This temperature is almost three times higher than the double concave window.

A more exact temperature field of a thin Be window subjected to a Gaussian type of heating $q'' = q_0 \exp\left(-\frac{r^2}{2\sigma_0^2}\right)$ is given as

$$T(r) = \frac{q_0 \sigma_0^2}{2kt} \left[\varepsilon\left(\frac{a^2}{2\sigma_0^2}\right) - \varepsilon\left(\frac{r^2}{2\sigma_0^2}\right) \right], \quad (7)$$

where $\varepsilon(r) = [E_1(r) - \ln(r)]$ and $E_1(x)$ is the exponential integral.

During beam missteering, the undulator beam can be 3 mm off-center. Thus, a larger amount of the undulator power is absorbed because of the increase in Be thickness in the beam path. An estimated 240 W (30% of total power) is intercepted when the beam

is missteered. Note that since beam missteering breaks the axisymmetry, a 3-dimensional model is needed for the temperature analysis. The temperature plots (Figure 6) show that the peak temperature rise for the missteered beam is 147 °C.

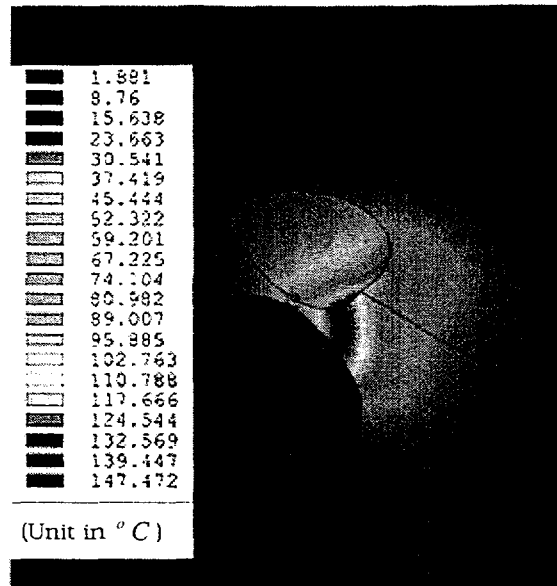

Figure 6. Temperature Contours in Be Window due to Beam Missteering

4. THERMOMECHANICAL ANALYSIS

The thermally induced failure is caused by either thermal buckling or thermal fracture. Buckling normally occurs before the fracture mode, especially in a thin window. With the double concave shape the window behaves more like a thick disk, which can increase the threshold of thermal buckling beyond that of the fracture mode. In this section, buckling analysis will be presented both for the thin Be window with constant thickness and for the present double concave Be window.

The stresses induced by the temperature field of Section 3 are also presented. For the thin Be window, the peak Von Mises effective stress of 70 ksi is obtained if an elastic model is used. The effective stress for the double concave window during normal operation is calculated to be 31 ksi at the center of the window. The effective stress contours of the double concave Be window are illustrated in Figure 7.

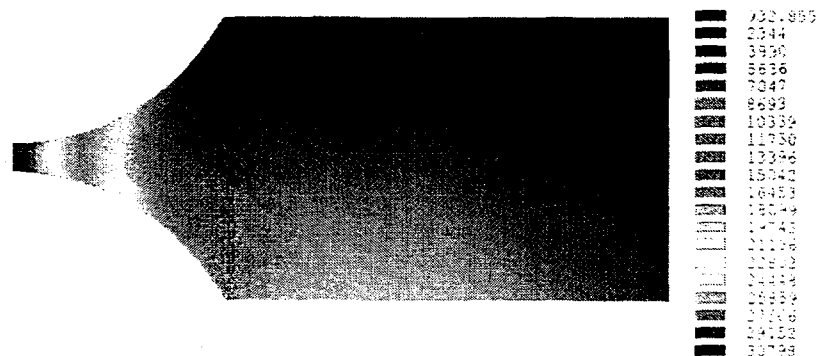

Figure 7. Effective Stress of Double Concave Be Window

Due to its lengthy derivation, the closed form buckling solution for a thin Be window is given in the Appendix. By taking two, three or four terms in Eq. (12), one finds the peak critical temperature of about 99 °C for a 0.5-mm thin window. The finite element model shows that the buckling occurs when the peak temperature reaches 110 °C, which corresponds to a positron beam current of 60 mA.

The finite element solutions were obtained using ANSYS. The Be window's out-of-plane deformations were calculated incrementally with increasing temperature. Thermal buckling was characterized by a large change in deformations for a small temperature increment. This method of calculating thermal buckling was used previously for a diamond disk².

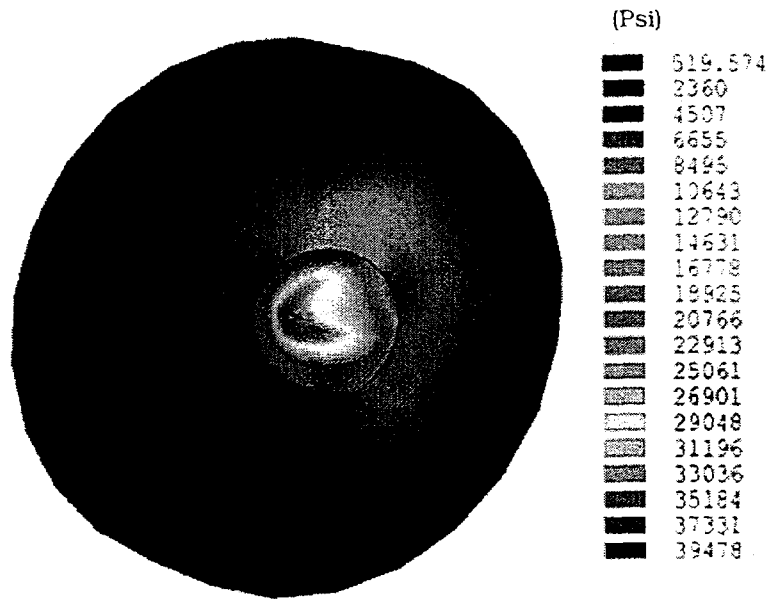

Figure 8. Effective Stress Contours Plot of the Be Window due to Beam Missteering

A double concave Be window was also modeled using ANSYS. The model predicted no buckling even at twice the power density, both for the centered and the missteered beams. Thermal stress calculations (Figure 8) show a maximum effective stress of approximately 40 ksi. The peak stress occurs at the center of the window instead of at the beam footprint. This is because the compressive forces generated by the temperature gradients produce higher stresses at thinner cross sections. Note that the yield stress for Be at 200 °C is about 47 ksi, and thus yielding does not occur in the window at 100 mA.

5. SUMMARY AND CONCLUSIONS

A novel Be window design of double concave geometry has been described. In this geometry, the absorbed beam power is reduced at the thinner center while heat conduction and stiffness of the windows are increased. A thermal buckling analysis is presented to show that there is no buckling even at temperatures that would result in stresses as high as twice the yield stress. Table 1 summarizes the thermal and thermomechanical analyses.

Table 1. Summary of Thermal and Thermomechanical Analyses

	Thin Be window (0.5mm thickness, normal operation)	Double concave Be window	
		Normal operation	Beam missteering
Power intercepted (W)	40	40	240
Peak temperature (°C)	173	61	147
Peak thermal stress at 7 GeV, 100 mA (ksi)	71	31	40
Buckling temperature (°C)	110	N/A ^a	N/A ^a
Safety beam current (mA)	63 ^b	152 ^c	120 ^c

^a We doubled the total power in the thermal buckling analysis and no buckling is occurred within this temperature region.

^b Based on minimum critical peak temperature.

^c Based on yield stress of Be at 200 °C 47 ksi.

The window described in this paper was installed on the APS diagnostics beamline and has been in successful operation since February 1997.

ACKNOWLEDGEMENTS

The authors would like to thank Ms. Catherine Eyberger for editing this paper. The work is supported by the U.S. Department of Energy, Office of Basic Energy Sciences, under Contract No. W-31-109-ENG-38.

APPENDIX

To calculate analytically the *critical buckling peak temperature* T_p^{cr} , which is the minimum temperature (at the center of the window) that causes thin window to buckle, we first rewrite the temperature field in Eq. (7) as

$$T(r) = \frac{T_p}{\varepsilon\left(\frac{a^2}{2\sigma_o^2}\right) + \gamma} \left[\varepsilon_1\left(\frac{a^2}{2\sigma_o^2}\right) - \varepsilon_1\left(\frac{r^2}{2\sigma_o^2}\right) \right], \quad (8)$$

where the relation

$$T_p = \lim_{r \rightarrow 0} T(r) = \frac{q_o \sigma_o^2}{2kt} \left(\varepsilon\left(\frac{a^2}{2\sigma_o^2}\right) + \gamma \right) \quad (9)$$

is employed and $\gamma = .57721..$ is Euler's constant. Utilizing the equilibrium equation, the constitutive equation, and stress-strain relations, the corresponding radial thermal stress σ_{rr}^o for an unbuckled thin plate under this temperature distribution is given as

$$\sigma_{rr}^o = \frac{T_p \alpha E \sigma_o^2}{\varepsilon\left(\frac{a^2}{2\sigma_o^2}\right) + \gamma} \left[\left(\frac{\sigma_o^2}{a^2} - \frac{\sigma_o^2}{r^2} \right) \left(\exp\left(-\frac{r^2}{2\sigma_o^2}\right) + \frac{r^2}{2\sigma_o^2} \left(\varepsilon_1\left(\frac{a^2}{2\sigma_o^2}\right) - \varepsilon_1\left(\frac{r^2}{2\sigma_o^2}\right) + 1 \right) + \frac{1}{2} \left(\frac{\sigma_o^2}{r^2} - \frac{r^2}{2\sigma_o^2} \right) \right) \right] \quad (10)$$

where α is the thermal expansion and E is the Young's modulus. Note that the thermal stress σ_{rr}^o will be used as the driving force that causes the window to initiate buckling. T_p will be treated as the only unknown parameter to be solved for the peak critical buckling temperature T_p^{cr} . Introducing finite deformation potential energy in an axisymmetrical coordinate³,

$$V = \frac{D}{2} \int_0^a r dr \left[(\nabla^2 w)^2 - 2(1-\nu) \left(\frac{\partial^2 w}{\partial r^2} \frac{1}{r} \frac{\partial w}{\partial r} \right) \right] + \frac{t}{2} \int_0^a r dr \left[\left(\frac{\partial w}{\partial r} \right)^2 \sigma_{rr}^o \right], \quad (11)$$

where D is the plate flexural stiffness defined as $\frac{Et^3}{12(1-\nu^2)}$ and w is the off-plane deflection. In order to solve for the peak

critical buckling temperature T_p^{cr} , we assume that the circumferential area is clamped and the maximum deflection occurs at the center of the window when the window starts to buckle. To satisfy these conditions, the deflection w must have the form

$$w = w_o \left(1 - \frac{r^2}{a^2}\right)^2 \sum_i c_i \left(\frac{r}{a}\right)^{2i} = w_o \sum_i c_i R_i(r), \quad (12)$$

where w_o is the maximum deflection that occurs at the center of the Be window and c_i represents the undetermined coefficients associated with the polynomial expansion $R_i(r)$. Substituting Eq. (12) into (11) and using the Rayleigh-Ritz energy method with Eqs. (11) and (12), an eigenvalue equation is obtained:

$$\mathbf{A} + T_p^{cr} \mathbf{B} = \mathbf{0}, \quad (13)$$

where

$$A_{ij} = \frac{D}{2} \int_0^a r dr \left[2\nabla^2 R_j(r) \nabla^2 R_i(r) - 2(1-\nu) \left(\frac{R_i''(r)R_j'(r) + R_j''(r)R_i'(r)}{r} \right) \right] \quad (14)$$

and

$$B_{ij} = \frac{h}{2} \int_0^a r dr \left[2R_i'(r)R_j'(r)\sigma_{rr}^o(r) \right]. \quad (15)$$

As there is no simple form to express T_p^{cr} , the critical temperature is solved numerically by using *Mathematica*®.

REFERENCES

1. P. Holman, *Heat Transfer*, McGraw-Hill Book company, 1977.
2. S. P. Timoshenko and J. M. Gere, *Theory of Elastic Stability*, McGraw-Hill Book Company, 1961.
3. H.L. Nian, T. M. Kuzay and I. C. Sheng, "Thermal Buckling Parametric Analysis for a Diamond Disk for an X-ray Beamline at the Advanced Photon Source," *Rev. Sci. Instrum.* 67 (9), September 1996.
4. *Mathematica*® is a registered trademark of Wolfram Research, Inc., Champaign, Illinois.