

CAP

BNL - 65685
CAP - 225-MUON-98C

CONF-980671--

A NEW STRUCTURE OF LINEAR COLLIDER *

Yongxiang Zhao
Brookhaven National Laboratory
Upton, NY, 11973

RECEIVED
AUG 17 1998
OSTI

*This work was supported by the US Department of Energy
under Contract No. DE-AC02-98CH10886.

DISTRIBUTION OF THIS DOCUMENT IS UNLIMITED

MASTER

July 1998

CENTER FOR ACCELERATOR PHYSICS

BROOKHAVEN NATIONAL LABORATORY
BROOKHAVEN SCIENCE ASSOCIATES

Under Contract No. DE-AC02-98CH10886 with the
UNITED STATES DEPARTMENT OF ENERGY

DISCLAIMER

This report was prepared as an account of work sponsored by an agency of the United States Government. Neither the United States Government nor any agency thereof, nor any of their employees, makes any warranty, express or implied, or assumes any legal liability or responsibility for the accuracy, completeness, or usefulness of any information, apparatus, product, or process disclosed, or represents that its use would not infringe privately owned rights. Reference herein to any specific commercial product, process, or service by trade name, trademark, manufacturer, or otherwise does not necessarily constitute or imply its endorsement, recommendation, or favoring by the United States Government or any agency thereof. The views and opinions of authors expressed herein do not necessarily state or reflect those of the United States Government or any agency thereof.

DISCLAIMER

**Portions of this document may be illegible
electronic image products. Images are
produced from the best available original
document.**

A NEW STRUCTURE OF LINEAR ACCELERATOR

Yongxiang Zhao,

Brookhaven National Laboratory, NY, USA

Abstract

A new scheme is proposed for the muon collider cooling RF, on which the cavity is almost a simple pill-box. The principle is to divide the accelerating cells into three separate channels with a phase difference of $2\pi/3$ between each other. A special structure is designed in which each channel is like a side-coupled cavity structure operating at $\pi/2$ -mode, but an extra phase shift of π is introduced so that the phase difference between two cells is 2π . Therefore, the beam sees a $2\pi/3$ -mode implying a high interaction between cavities and beam, while the RF system sees a $\pi/2$ -mode implying a high stability. In other words, it combines the advantages of both traveling wave and standing wave. The mechanical structure is also simple and compact because the side-coupled cavity is formed by a uniform rectangular-like waveguide, which is simply an arc section attached on the main cavities. The principle and the preliminary simulation are addressed in detail. This principle is also applicable for a $2\pi/4$ mode and other machine provided the coupling due to aperture is weak enough.

1 INTRODUCTION

The muon collider is considered as an important future project for the high energy physics. One of the challenges is to cool the muon beam. It requires very high gradient with relatively low frequency, say 800 MHz. Since the total RF power is very large, minimising the RF power is of much concern. Meanwhile a high magnetic field has to be applied for beam focusing. Consequently, the acceleration structure is required to be compact as well.

To meet above requirements, a few issues were considered. A normal cavity with a beam aperture, the ratio of maximum surface field to the acceleration gradient is greater than 2 or more. If a pillbox cavity is used, with the aperture for beam path being closed by a beryllium foil window, the ratio is one and thus enhances the acceleration gradient within the breakdown limit. Beryllium is a light metal causing little loss when a muon beam passing through. Another measure is to apply liquid nitrogen to cool down the cavity so that significantly reduces the RF power requirement.

The accelerator structure is also an important issue. A few structures were considered. The standing wave structure has highest impedance thus least power requirement, but poor mode separation leads poor stability. Side-coupled cavity structure (SCS) working at $\pi/2$ -mode can overcome this problem, but it is asymmetric making structure complex and has much large

transverse dimension[1]. Besides the beam transit time is π , consequently the transit time factor is low. A travelling wave structure can work at $2\pi/3$ or $\pi/2$ mode has higher transit time factor, but the field will decay along the structure and a damper at the end is needed. Not only it complicates the structure, but also wastes the power. One possible solution is to recycle the remained power by connecting the outlet to the inlet to form a travelling wave resonator ring. This arrangement will make full use of the available power. However, the loop structure requires two ports on the accelerator, it is difficult from mechanical consideration, that there are solenoids surrounding the accelerator. Therefore, a new structure is proposed [2] and addressed as below.

2 THE PRINCIPLE OF THE $2\pi/3$ -MODE INTERLEAVED STRUCTURE

Fig.1 shows the principle. At the input of the accelerator a 3-branches power divider is inserted so as to form three independent channels. There is a phase difference of $2\pi/3$ between each other. Each channel will connect only to one of every three cells of the accelerator structure, i.e. channel-1 only couple with those cells numbered #1, #4, #7... channel-2 with #2, #5, #8... channel-3 with #3, #6, #9.... The cells are coupled by the side cavities to form a side coupling accelerator structure. As usual, it works in $\pi/2$ -mode; i.e. the adjacent cavity has $\pi/2$ phase shift.

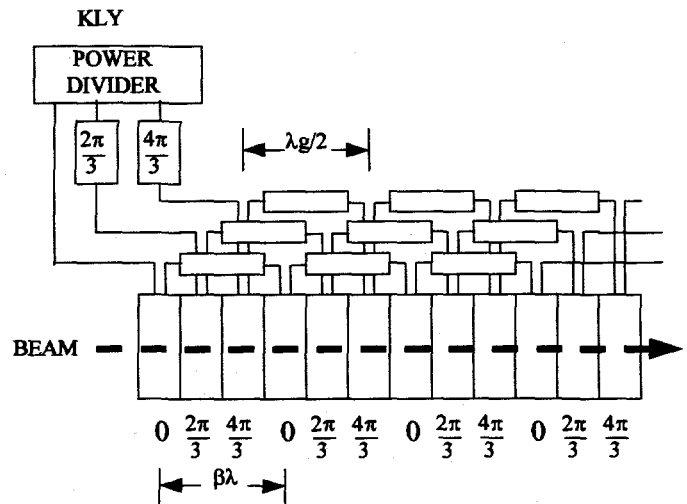

Fig.1 The principle diagram

The schematic structure is shown in Fig. 2. The side-coupled cavity is simply a piece of rectangular-like

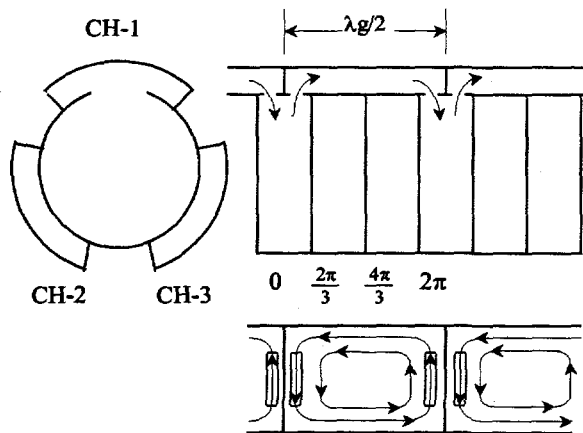

Fig. 2 Schematic structure

waveguide with its wide side bent. Its length is a half of waveguide wavelength. On its both sides there are two slots coupling to two acceleration cells. The bottom of Fig. 2 shows the magnetic field pattern in the side-coupled cavity, clearly, magnetic field at both ends of a cavity has opposite direction, and it causes an extra phase shift of π . Thus between two acceleration cells there are 2π phase shift.

Fig.2 shows the case of a travelling wave from left to right with $\pi/2$ -mode. The arrows show the direction of energy flow. For a $\pi/2$ -mode, between two adjacent cavities, i.e. cross each slot, there's $\pi/2$ phase shift. Across two adjacent slots, there's π phase shift. As shown on the magnetic pattern, the directions of the magnetic field on two slots are opposite each other, meaning π shift. However, the whole pattern of two adjacent cavities is the same, meaning they are in phase or 2π shift. That is because an extra π is introduced as mentioned above.

Now, let the left most and right most acceleration cavities serve as short end, then the wave will reflect and form a standing wave. In this case, the side coupled cavities will locate at wave node, so that the field inside them are very weak. Therefore the side-coupled cavity can be made with small height without the risk of breakdown. That is a thin waveguide attaching to the accelerator, making the structure very compact.

In brief, it combines both advantages of standing wave structure and travelling wave structure. From the viewpoint of beam it is a TW with $2\pi/3$ -mode, that has higher transit time factor than that of a π -mode. Meanwhile from the viewpoint of the RF source it looks as standing wave structure, with high impedance and no power wasted. Besides, it retains the advantage of $\pi/2$ -mode of the best mode stability.

3 SIMULATION

MAFIA simulation was done to verify the principle. The chosen parameters are listed below:

Acceleration cells:	Cell Diameter	0.285m
	Cell length	0.10m.
	Period (3 cells)	0.312m
Side cavity:	Outer diameter	0.316m
	Inner diameter	0.296m
	Span angle	79.74deg
	Length	0.306m
Coupling slot:	Span angle	45deg
	Width	0.01m
	Off edge	0.03m

Fig.3 shows the result of MAFIA simulation. The frequency is 795 MHz. We chose one side coupled cavity and two half of acceleration cavities of one channel. The central part refers to cavities of other channels. It was excluded because they are independent without energy coupling. It shows clearly that the field in both acceleration cells is in phase or 2π , while the field in the side cavity is pretty small. This verifies the argument addressed in previous section.

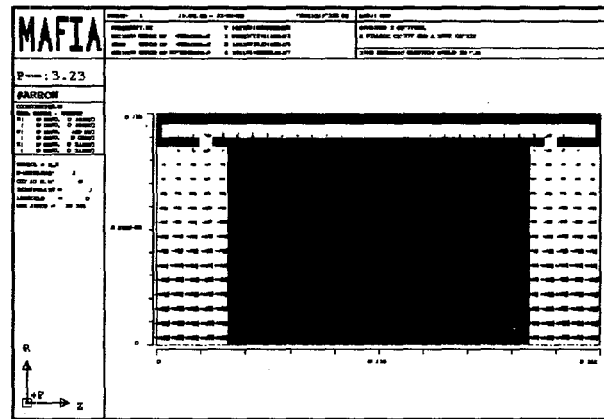

Fig.3 The electric field pattern from MAFIA

4 DESIGN APPROACH FOR THE BI-PERIODIC STRUCTURE

The structure in question is bi-periodic. Besides, the unique character of an extra π phase shift calls for care with the simulations. On Fig.3, from left boundary to right boundary there is 2π or 0 phase difference, it implies that 2π or 0 degree phase advance must be assigned when run MAFIA. But, from the viewpoint of RF circuit, it has only π phase shift not 2π . In fact, between two adjacent cavities there is only $\pi/2$ phase shift. This can also be verified by MAFIA running with periodic structure of 0 degree phase advance. The field pattern of E_{re} and E_{im} , i.e. the real and image part of the field or the fields in 90 degree phase difference, show the electric field will concentrated in either acceleration cavity or side coupled cavity. Thus it is a $\pi/2$ -mode indeed and should have all

the $\pi/2$ -mode properties. The following formula should be kept in mind.

$$\phi_{\text{MAFIA}} = 2\phi + \pi$$

where ϕ_{MAFIA} is the value assigned to MAFIA file, ϕ is the phase referring to the mode.

Fig.4 shows the $f-\phi$ curve, i.e. $\omega-\beta$ diagram. The operation point is chosen at the middle, $\pi/2$, (at MAFIA run it is 0 degree) where the group velocity is maximum and has maximum mode separation. It is also a cross point of two modes, i.e. acceleration mode and side coupling mode.

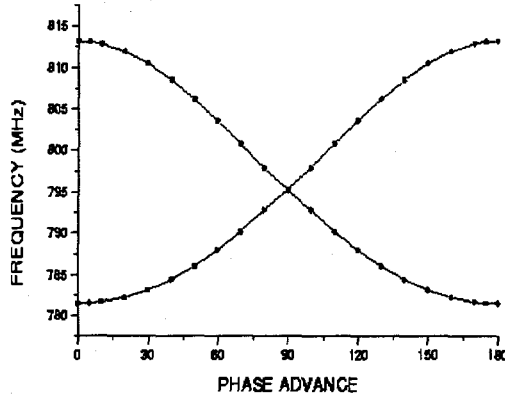

Fig.4 The dispersion curve

Note that the two modes are in junction only if the resonant frequencies of accelerator and side cavities are equal or close enough. Otherwise the two modes will separate. Fig.5 shows the case.

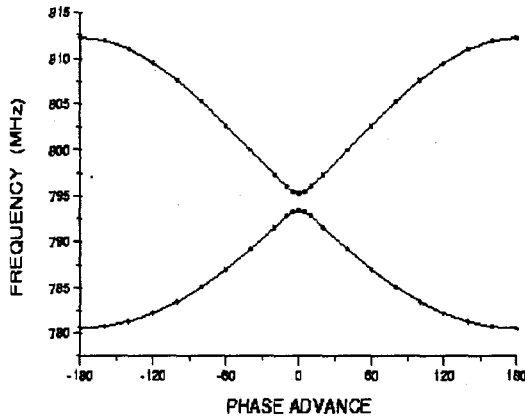

Fig.5 Two pass band not matched

Fig.5 is the case that the side-coupled cavity has a little lower frequency. The lower pass band corresponds to side coupling mode, while the upper band acceleration mode.

In this case the frequency of 795MHz will no longer be at $\pi/2$ -mode, instead it is at π -mode, that this structure is regarded as a single periodic, while the side cavity is off resonance. Then the phase relationship should be:

$$\phi_{\text{MAFIA}} = \phi + \pi, \text{ OR } \phi_{\text{MAFIA}} = \phi - \pi$$

In this case all the advantages of $\pi/2$ -mode has lost. Therefore carefully adjusting the frequency is important for the design. By virtue of MAFIA, a result of matched frequency has been obtained as shown in Fig.4.

5. SOME COMMENTS

The above discussed structure has many advantages. It works on standing wave with high impedance and without damper in comparison with traditional travelling wave structure. It works on $\pi/2$ -mode and avoid the shortcomings of simple standing wave structure working at π -mode with zero group velocity making long filling time and poor stability due to poor mode separation. It has very simple structure and compact size in comparison with a common side coupled cavity structure, which usually encounter difficulties.

This principle can also be applied to four channels with a $\pi/2$ phase difference between each channel that beam sees a $2\pi/4$ mode. Two channel interleaved structure has been used long time ago. However, present simple side coupled cavity is not applicable because the length of the waveguide-like cavity must be longer than $\lambda g/2$, while the length of beam travel of $\beta\lambda/2$ is less than that.

The disadvantage of the structure is the requirement of a three-channel high power splitter, which makes the input system being complex.

6 ACKNOWLEDGEMENT

This work was supported by the US DOE under Contract No. DE-AC02-76CH00016. The author was especially indebted to R. Palmer for his enlightening comments. Thanks also to many collaborators for beneficial discussions.

REFERENCES

- [1] T. G. Jurgens, H. W. Miller, A. Moretti and P. Zhou, "The determination of the 805 MHz side coupled cavity dimensions for the Fermi Lab linac upgrade", Proc. 1990 Linear Accelerator Conference, Sep. 10-14, 1990.
- [2] Y. X. Zhao, "The simulation of $2\pi/3$ -mode interleaved structure", Muon RF workshop, Lawrence Berkeley Laboratory, Feb.17-18, 1998