

RECEIVED
SFP 28 1999
OSTI

An Advanced ISOL Facility Based on ATLAS

J. A. Nolen, K. W. Shepard, R. C. Pardo, G. Savard, K. E. Rehm,
J. P. Schiffer, W. F. Henning, C.-L. Jiang, I. Ahmad, B. B. Back,
R. A. Kaye, M. Petra, M. Portillo, J. P. Greene, B. E. Clift,
J. R. Specht, R. V. F. Janssens, R. H. Siemssen,
I. Gomes,* C. B. Reed,* A. M. Hassanein[†]

*Physics Division, *Technology Development Division, [†]Energy Technology Division
Argonne National Laboratory, Argonne, IL 60439 USA*

Abstract. The Argonne concept for an accelerator complex for efficiently producing high-quality radioactive beams from ion source energy up to 6-15 MeV/u is described. The Isotope-Separator-On-Line (ISOL) method is used. A high-power driver accelerator produces radionuclides in a target that is closely coupled to an ion source and mass separator. By using a driver accelerator which can deliver a variety of beams and energies the radionuclide production mechanisms can be chosen to optimize yields for the species of interest. To effectively utilize the high beam power of the driver two-step target/ion source geometries are proposed: (1) Neutron production with intermediate energy deuterons on a primary target to produce neutron-rich fission products in a secondary ^{238}U target, and (2) Fragmentation of neutron-rich heavy ion beams such as ^{18}O in a target/catcher geometry. Heavy ion beams with total energies in the 1-10 GeV range are also available for radionuclide production via high-energy spallation reactions. At the present time R&D is in progress to develop superconducting resonator structures for a driver linac to cover the energy range up to 100 MeV per nucleon for heavy ions and 200 MeV for protons. The post accelerator scheme is based on using existing ISOL-type 1+ ion source technology followed by CW Radio Frequency Quadrupole (RFQ) accelerators and superconducting linacs including the present ATLAS accelerator. A full-scale prototype of the first-stage RFQ has been successfully tested with RF at full design voltage and tests with ion beams are in progress. A benchmark beam, ^{132}Sn @ 7 MeV/u, requires two stripping stages, one a gas stripper at very low velocity after the first RFQ section, and one a foil stripper at higher velocity after a superconducting-linac injector.

INTRODUCTION

There is much enthusiasm in the nuclear physics community for the research opportunities that would be enabled by an advanced, high intensity accelerated radioactive beam facility based on the isotope-separator on-line (ISOL) method. There are recent reports from both North American and European study groups (1,2). A group including many ANL Physics Division staff and ATLAS outside users has discussed the research possibilities and prepared a working paper entitled "Concept for an Advanced Exotic Beam Facility Based on ATLAS." The working paper is available on the World Wide Web at the ANL Physics Division home page

DISCLAIMER

This report was prepared as an account of work sponsored by an agency of the United States Government. Neither the United States Government nor any agency thereof, nor any of their employees, make any warranty, express or implied, or assumes any legal liability or responsibility for the accuracy, completeness, or usefulness of any information, apparatus, product, or process disclosed, or represents that its use would not infringe privately owned rights. Reference herein to any specific commercial product, process, or service by trade name, trademark, manufacturer, or otherwise does not necessarily constitute or imply its endorsement, recommendation, or favoring by the United States Government or any agency thereof. The views and opinions of authors expressed herein do not necessarily state or reflect those of the United States Government or any agency thereof.

DISCLAIMER

Portions of this document may be illegible in electronic image products. Images are produced from the best available original document.

Simplified Schematic Layout of the ANL ISOL Facility

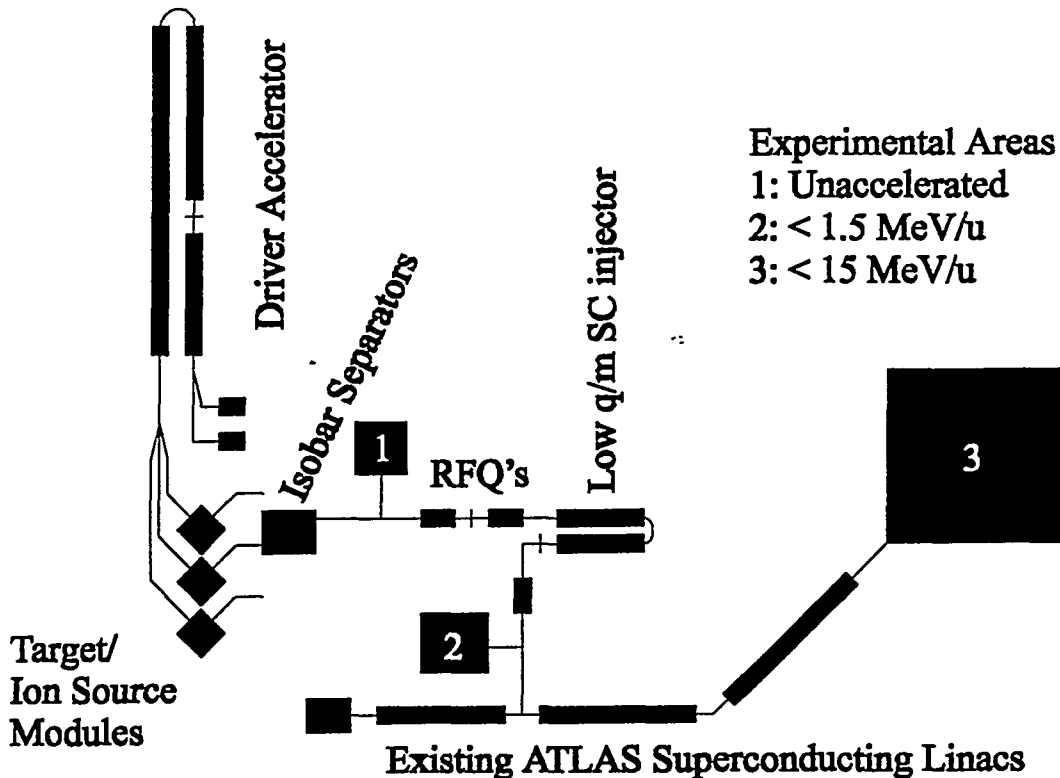
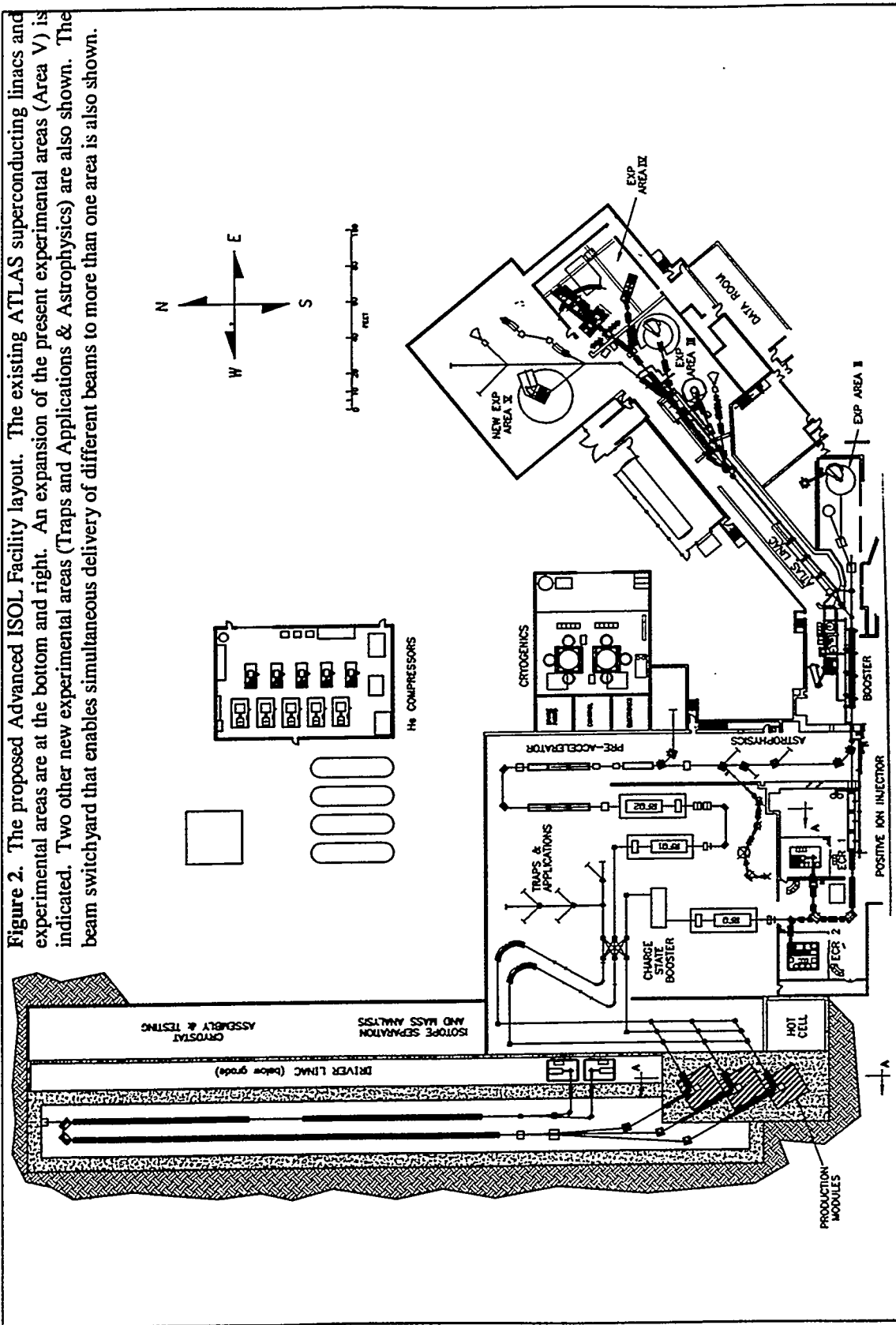

FIGURE 1. A block diagram of the proposed Advanced ISOL Facility based on ATLAS at Argonne. The major components of the complex, including the three different experimental areas, are indicated. The details of the low energy beam switchyard that connects the three target modules to the various experimental areas and/or post accelerators are not shown.

(<http://www.phy.anl.gov>). The U.S. Nuclear Science Advisory Committee (NSAC) included a strong recommendation for the construction of an Advanced ISOL Facility in its 1996 Long Range Plan. The scientific case for such a facility was summarized recently in a White Paper (3). The present paper is a status report of the Argonne concept originally presented in the working paper in 1995. An alternative concept for an Advanced ISOL Facility to be located at the Spallation Neutron Source is being developed at ORNL and is described by J. D. Garrett at this conference (4).

A schematic block diagram of the facility conceived by ANL is shown in Fig. 1 and a more detailed layout of the proposed complex is shown in Fig. 2. The present ATLAS complex produces state-of-the-art heavy ion beams covering the entire mass range from protons to uranium for nuclear physics research at energies above the Coulomb barrier. The new facility would build on the existing expertise in accelerator and nuclear physics at ATLAS. In Fig. 2 the existing ATLAS accelerators and experimental facilities are in the lower part of the figure, and the proposed driver

Figure 2. The proposed Advanced ISOL Facility layout. The existing ATLAS superconducting linacs and experimental areas are at the bottom and right. An expansion of the present experimental areas (Area V) is indicated. Two other new experimental areas (Traps and Applications & Astrophysics) are also shown. The beam switchyard that enables simultaneous delivery of different beams to more than one area is also shown.



linac, production target area, mass separators, new low energy experimental areas, and post accelerator injector are in the upper part. The new components for the radioactive beam laboratory will be constructed in the area just north of the present ATLAS facility. The capability of ATLAS to accelerate stable beams will remain independent of the added radioactive beam capability, both during construction and afterwards. The major components of the proposed facility are described in the following sections.

PRODUCTION MECHANISMS

The Argonne concept for the Advanced ISOL Facility utilizes a high power driver accelerator that can deliver a variety of beams and energies such that the radionuclide production mechanisms can be chosen to optimize yields for the species of interest. The production mechanisms include: (1) Neutron-induced fission in a secondary target following neutron production by deuterons on a primary target; (2) Fragmentation of neutron-rich heavy ion beams such as ^{18}O in a two-step target/catcher geometry; (3) Spallation reactions induced by heavy ions with total energies of 1 to 10 GeV; and (4) Compound nucleus reactions at lower beam energies when appropriate. This approach permits the choice of the optimal production method for specific isotopes while minimizing the production of unwanted byproducts. An Advanced ISOL Facility based on the multi-beam driver concept will address all thirteen of the physics areas spelled out in the Columbus White Paper (3).

DRIVER LINAC

The high-power, multi-beam driver being proposed is a superconducting linac capable of delivering over 100 kW of beam power for a variety of light and heavy ions. The preliminary design of this linac is based on using two-cell, 350 MHz spoke-type niobium resonators which are currently being developed (5). These new resonators are required at the high-velocity end of the linac ($\beta \sim 0.4$). More conventional, lower frequency inter-digital and quarter-wave resonators can be used at

TABLE 1. Typical Beams Available From the Driver Linac

Ion	Mass	Intensity	Energy	Energy	Power
		part./sec.	MeV/u	GeV	kW
Proton	1	8.0E+15	212	0.2	300*
Deuteron	2	7.0E+15	123	0.25	300*
Oxygen	16	1.0E+15	118	2	300*
Argon	40	1.7E+14	97	4	110
Krypton	82	1.2E+13	82	7	16
Xenon	132	2.4E+12	75	10	4

*The actual beam power limit will be set by the linac RF design specification.

the low velocity end of the linac. The ion source/injector for this driver accelerator can be a high-intensity version of the ECR ion source/high-voltage platform system currently used at ATLAS (6). Present-day ECR ion sources such as the AECR at LBNL (7) and SERSE at Catania (8) can provide DC beams of heavy ions such as those listed in Table 1 at intensities necessary to achieve the indicated beam powers with a single foil stripping at 10 MeV per nucleon. For the lighter ions such as protons and deuterons DC currents of well over a milliampere are available from conventional ion sources and no stripping is required. For the lighter ions the maximum beam power available will be set by the RF power design choice and will not be limited by the ion sources. In Fig. 2 the driver is shown with two ion source/injector platforms at the low energy end and three beam lines feeding target modules at the high-energy end. At either or both ends, RF switching can be used to simultaneously accelerate beams from alternate sources and irradiate multiple target modules.

TARGET COMPLEX

High-power beams from the driver linac are used to produce radionuclides in well-shielded target/ion source modules that are located below grade level to assist with shielding prompt neutron radiation. A preliminary investigation of the radiological issues to be encountered in the target complex of an Advanced ISOL Facility was carried out at LBNL (9) assuming 100 microamperes of 600 MeV protons. General radiation protection issues for such facilities were also reviewed recently by L. Moritz (10) of TRIUMF. The conclusions are that the level of radiological issues of the Advanced ISOL Facility is well within the realm of experience previously and currently encountered at meson factories such as TRIUMF and LAMPF, as well as at many non-reactor nuclear facilities at several DOE national laboratories such as Argonne.

As shown in Figs. 1 and 2, three target modules are included in this proposal. By using RF switching from the driver linac beams can irradiate targets in all three modules simultaneously. This enables, for example, target and ion source development to be carried out in one module while two are used as sources of radioactive beams for the nuclear physics research program.

Shielding and Remote Handling

The target complex shielding and remote handling designs worked out by the TRIUMF group for the ISAC facility can be applied to the present proposal. Paul Schmor described the ISAC facility, currently being commissioned at TRIUMF, at this conference (11).

High Power Targets

The production targets for the Advanced ISOL Facility must work at high beam power and, at the same time, be coupled efficiently to ion sources for the production of the secondary beams of short-lived isotopes. To effectively utilize beam powers of 100 kW or more involves extrapolation beyond current experience at any ISOL-type facility. For the Argonne multi-beam driver approach there are currently three basic concepts being developed in order to utilize the variety of radionuclide production mechanisms mentioned above. Based on preliminary engineering designs all three approaches can be used at beam powers up to 100 kW or more. The design problem can be viewed as one of minimizing target size and geometry while still handling the beam power. Minimizing target size and geometry is essential to optimize diffusion and effusion efficiencies for very short-lived radionuclides. Generally, the short-lived isotopes tend to be the most interesting and to have lower intrinsic production cross sections due to being further from stability.

Two of the three concepts being developed involve the so-called two-step geometry. In conventional ISOL production schemes the target and ion source are integrally coupled so that the primary target can not be massively cooled without interfering with the ion source performance. With the two-step schemes these functions are physically separated as described below.

The fusion power community has developed liquid lithium cooling loops for a variety of applications. Engineering designs have been carried out for stopping 10-MW deuteron beams in windowless flowing liquid lithium targets (12). Pumps for recirculating liquid lithium are commercially available and are quite small compared to those required for similar mass flow rates of helium gas (13). The two-step target concepts described below can both utilize this technology.

Two-step, Neutron-generator Targets

Figure 3 illustrates schematically a simple, two-step geometry for the production of large yields of neutron-rich fission products. In this example a primary beam of protons or deuterons impinges upon a well-cooled tungsten target to produce an intense flux of secondary neutrons. The secondary neutrons are relatively low energy and approximately isotropic. To optimize the solid angle of the secondary uranium target a cylindrical geometry is indicated. The length and diameter of the secondary target are kept to a minimum for optimal extraction of short-lived products. Using thicker and longer secondary targets can increase the yields of longer-lived isotopes. With the Los Alamos LAHET Code System (LAHET and MCNP), the fission fragment production rates can be calculated for realistic geometries (14). The calculated yield of the doubly magic nucleus ^{132}Sn (40 sec half-life) in a compact secondary target (2 cm radial thickness by 10 cm axial length) is 2×10^{11} per second with a 500-microampere, 200-MeV deuteron beam.

The geometry of Fig. 3 is well suited to the production of radionuclides that have high yields in low-energy-neutron-induced fission. This conclusion is based on

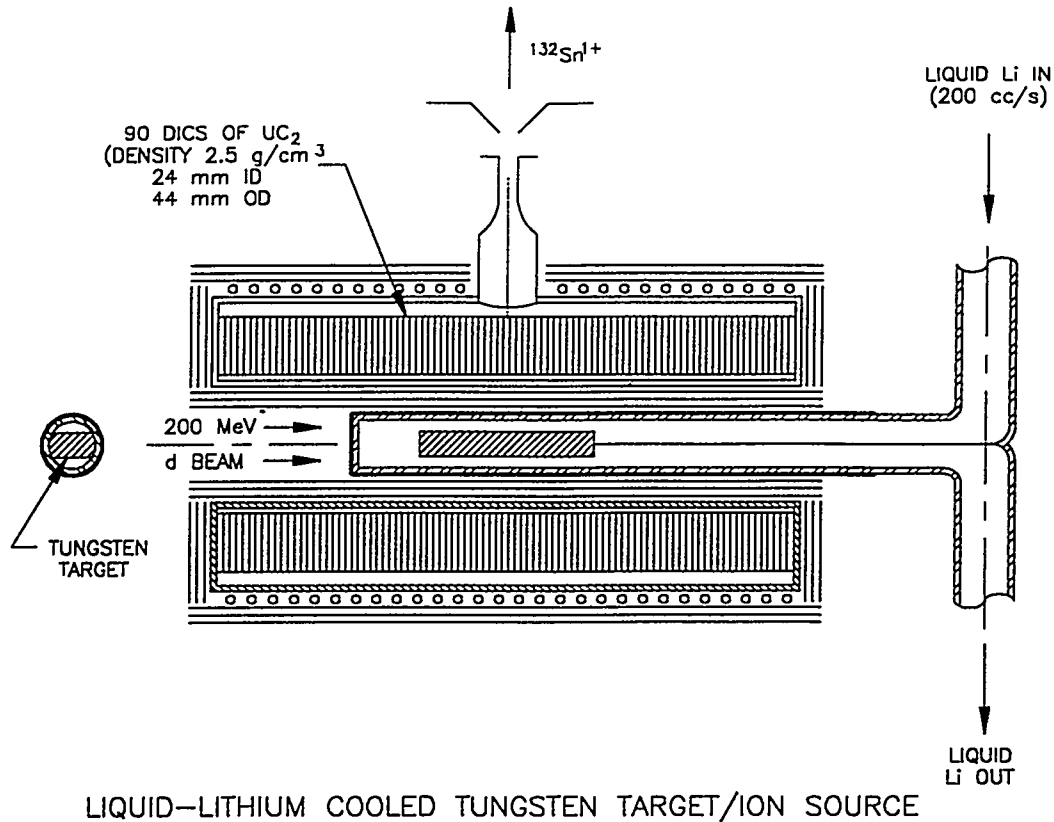

Figure 3. Schematic of a two-step, neutron-generator-type, high-power target for the production of fission fragments. A deuteron beam on a tungsten primary target produces secondary neutrons. Circulating liquid lithium cools the primary target. The secondary uranium carbide target is heated to 2000 C by a combination of the fission power and supplemental electrical power.

calculations of thin target yields of neutron-rich fission products for a range of neutron and proton energies from a few MeV up to 100 MeV (15). The best yields of neutron-rich isotopes of elements such as Kr, Rb, Xe, and Cs are from 2-20 MeV neutron-induced fission of ²³⁸U. Harder neutron spectra, such as produced via the originally proposed d+Be reaction (16), are likely to produce more radionuclides outside the standard low-energy, asymmetric fission mass range.

Fragmentation/catcher Targets

A schematic diagram of the second type of two-step target is shown in Fig. 4. Here a 100 kW heavy ion beam (e.g. ¹⁸O) is stopped in flowing liquid lithium while the neutron-rich fragments (e.g. ¹¹Li), which have a longer range and are kinematically forward peaked, go on and stop in the catcher/ion source that is physically separated downstream of the primary target. The purpose of the graphite in the primary target of Fig. 4 is to reduce the stopping thickness that would be required with pure lithium due to its very low density of 0.5 g/cm³. The target is designed to have the high-power-

LITHIUM-COOLED GRAPHITE TARGET/CATCHER ASSEMBLY

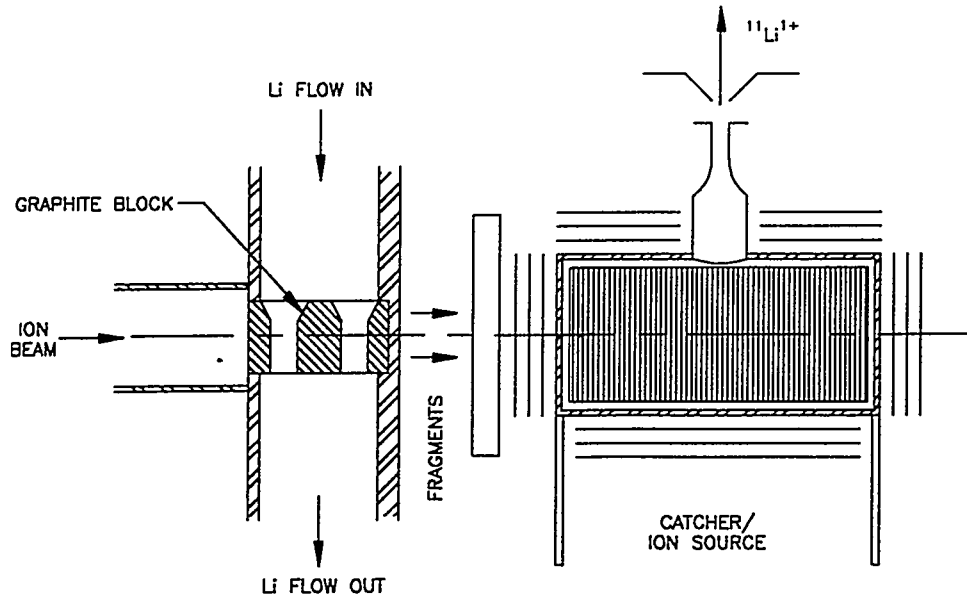

Figure 4. Schematic of a two-step, fragmentation/catcher target combination. A high-power, neutron-rich heavy ion beam, such as ^{18}O , stops in the primary target that consists of a combination of graphite and liquid lithium coolant. The neutron-rich, lower-Z fragments, such as ^{11}Li , have a much longer range than the primary beam and are stopped in the downstream catcher. The catcher is close-coupled to the ion source and is optimized for rapid release of the short-lived fragments.

density Bragg peak occur in the flowing liquid lithium. For heavier ions such as Kr and Xe the ranges are short enough to use pure liquid lithium primary targets.

With the target geometry of Fig. 4, known fragmentation cross sections for ^{11}Li (17), and graphite catchers optimized for rapid release of alkalis (18), mass separated beams of 5×10^7 ^{11}Li per second are predicted. This is a very high intensity for such a short-lived isotope (9 ms half-life).

A new development that is currently being tested in conjunction with ion accumulation for the Canadian Penning Trap (19) may lead to significant improvement over the concept illustrated in Fig. 4. By stopping the fragmentation products in a high-pressure gas cell of pure helium or argon, and using a combination of rf and static electric fields as in (19), the radionuclides come to rest as $1+$ ions. They are quickly extracted from the gas volume with high efficiency independent of the chemical properties.

Direct Irradiation Spallation Targets

A third target design concept is being developed to utilize an important radionuclide production mechanism, heavy-ion-induced spallation of heavy targets such as uranium. Large yields of very neutron-rich sodium isotopes, for example, were observed in the pioneering work with 86 MeV per nucleon (0.9 GeV total energy) carbon beams at the ISOLDE facility at the CERN Synchrocyclotron (20, 21).

Based on these ISOLDE yield measurements, scaled to 100 kW of 1.4 GeV carbon beam on a UC_x target, mass separated beams of ^{31}Na (17 ms half-life) could be obtained with very high intensities, over 5×10^6 per second. However, this requires a direct irradiation of the UC_x target with the intense carbon beam; the two-step geometries are not applicable. Direct irradiation of the standard low-density porous UC_x used at ISOLDE (22) can not be scaled to high beam power due to the very low thermal conductivity of this form of the material (23). Hence, a new geometry for irradiating a large area sheet of thin ($\sim 100 \mu\text{m}$ to 1 mm thick) higher density UC_x is being considered. A large area sheet tilted at a large angle to the driver beam can dissipate the large beam power by black body radiation while the higher thermal conductivity combined with the thin sample dimensions prevent high internal temperatures within the sheet. This geometry leads to a very open geometry that should yield very short effusion times. Analysis of this scheme taking into account the overall diffusion from the UC_x and the effusion from the open geometry target chamber will be carried out using methods similar to those discussed by Roger Bennett (24) and Will Talbert (25) at this conference. New measurements of the thermal conductivity and radionuclide release properties of UC_x prepared at various densities will have to be made. With beams of 1.4 GeV carbon, 2 GeV neon, and 4 GeV argon from the heavy ion driver, this reaction mechanism and target concept could prove to be extremely productive.

Ion Sources

The present proposal is based on the ISOL-type ion source technology that has been continuously developed and refined at various laboratories over the past 30 years. See (26) for a review and many references on these ion sources. These types of ion sources produce a wide variety of atomic species with high efficiency and varying degrees of chemical selectivity, usually in the 1+ charge state. Chemically selective, laser-driven ion sources have developed rapidly in recent years and have been shown to be very useful at ISOL facilities (27). Major advantages of standard 1+ ISOL-type ion sources are their high ionization efficiencies and their relatively radiation-resistant, simple construction. Furthermore, designing the overall post-accelerator scheme to work with 1+ ions enables the implementation of new concepts such as the gas fragment catcher discussed above.

ISOBAR SEPARATOR

The goal of the Advanced ISOL Facility is to produce energetic beams of short-lived isotopes far from the valley of nuclear stability. The beams are to be of high quality (excellent emittances) and as free of contaminants as possible. For some elements there are chemically selective ionization processes, such as surface ionization for the alkalis and the laser resonance ionization process for others. And for other elements physical separation processes are possible, such as cold transfer lines for the

noble gases. In these cases it is adequate to produce mass separated beams with resolution $m/\Delta m \sim 500$. However, in non-selective cases a specific radionuclide of interest may be associated with a much more intense neighboring isobar. Separation of isobars requires mass separation with resolution of 20,000 or more. Important parameters of the isobar separator are the emittance acceptance and energy spread compensation. The present proposal is to include one or two large isobar separators (see Fig. 2) with emittance acceptances of 10π mm-mr at 100 keV ion beam energy and the ability to compensate for ion source energy spread or voltage ripple of at least 10-20 eV. The ion-optical scheme of using two magnetic separators with ion energy deceleration in between, as originally proposed by H. Wollnik; will be used. See (28) for another example of this type of isobar separator. In the future it may be possible to enhance the performance of the isobar separator by incorporating new technology which is on the horizon. The new concept is to effect cooling of the $1+$ ion beams via a buffer-gas/ion guide scheme (29).

POST ACCELERATOR

An essential feature of the post accelerator is to preserve the excellent beam quality currently available at ATLAS for stable beams of any mass up to uranium in the energy range from 6-15 MeV per nucleon. The post accelerator starts with mass separated, $1+$ radioactive ion beams at initial energies of 50-100 keV. A high overall efficiency of the acceleration process is of the utmost importance.

Stripping Scheme

The science program of the Advanced ISOL Facility requires delivering mass separated ion beams at three qualitatively different energies: unaccelerated beams at ion source energy, beams in the 1 MeV per nucleon energy range, and beams accelerated to 6-15 MeV per nucleon. For ions of the lower energies and atomic masses it is possible to deliver the beams with very high efficiency, directly in the $1+$ charge state. However, economic considerations necessitate the use of one or two stages of ion stripping for the higher mass ions to be accelerated to the higher energies. The present proposal involves stripping in a thin helium gas cell, to $2+$ or $3+$, after the initial acceleration in the RFQ, for masses above 70. The efficiency for this process has been shown to be 40-50% for a broad range of heavy ions (30). For acceleration to energies above 600 keV per nucleon a foil stripper is used to increase the charge-to-mass ratio to > 0.15 , with a typical efficiency of about 20%. Hence, the overall efficiency of the process varies with both mass and energy depending on the need for: no stripping (100%), gas stripping only (~40-50%), foil stripping only (~20%), or both strippers (~8-10%).

Various groups around the world are developing alternates to gas or foil strippers, the so-called charge breeders (31, 32, 33). As indicated in Fig. 2, one of these charge breeder concepts could be incorporated into the present proposal. In the scheme shown in Fig. 2 the charge breeder is used for the beams with mass $A > 70$, for acceleration to energies of 6-15 MeV per nucleon. This is the category of beams for

which the breeders are likely to be most competitive with the stripping alternative (8-10%), at least initially. Incorporation of the breeder scheme into this proposal in this way takes advantage of the present injector stage of ATLAS, and permits the simultaneous delivery of radioactive beams to the high energy experimental areas and one or both of the lower energy areas.

First Accelerator Section: CW RFQ

The capability of the Advanced ISOL Facility to deliver high quality beams with high efficiency over a broad range of masses and energies from $1+$ ion sources depends critically on the first stage of acceleration: The present proposal is based on the use of a low-frequency, normally conducting, CW radio-frequency quadrupole (RFQ) acceleration section that is currently under development at Argonne (34), with a status report at this conference. The acceptance of this type of RFQ, which would be operated on a negative high voltage platform, is well matched to typical ISOL-type ion source emittances and is expected to be useful for initial acceleration of $1+$ ions with masses up to ~ 200 . This type of RFQ is also adaptable for matching a charge breeder to the present ATLAS superconducting injector, as indicated schematically in Fig. 2.

Superconducting Linacs

Following the normally conducting RFQ accelerator sections described above, all of the radioactive beam acceleration is done with superconducting linear accelerators. [see (35) for a description of this injector] The present proposal is to add a high charge-to-mass ratio injector section ($m/q < 70$) for the initial acceleration up to 600 keV per nucleon. The superconducting resonators of this section are of the same type currently in use for the ATLAS low-velocity injector ($v \geq 0.008c$). However, due to the higher mass-to-charge ratio of the new injector, the transverse focussing requirements are more demanding. The present concept is to use high-gradient superconducting quadrupole triplets for focussing in the new injector as opposed to the superconducting solenoid focussing elements used in the present ATLAS injector. Beams from the high m/q injector can be delivered, without further stripping, at energies up to 600 keV/u to either the intermediate energy experimental areas or transported without further acceleration to the apparatus in the high-energy experimental areas. For acceleration to energies above 600 keV/u the high m/q injector is followed by the foil stripper and a short superconducting matching section. The matching section provides beams at up to 1.2 MeV/u in the intermediate energy experimental areas or delivers the beam for further acceleration by the present ATLAS linacs. Energies up to the 6-15 MeV per nucleon range, depending on ion mass, are available in the high-energy experimental areas.

EXPERIMENTAL AREAS AND INSTRUMENTATION

The research enabled by the Advanced ISOL Facility is discussed in the Columbus White Paper (3). As pointed out in the discussion of the stripping scheme above, there are three qualitatively different energy regimes required for this research program. The associated experimental areas are indicated and labeled in the block diagram of Fig. 1 and shown in more detail in Fig. 2. In addition to the areas indicated there is space for further expansion as future needs dictate. The experimental apparatus deemed necessary to carry out the proposed research program was the subject of a workshop sponsored jointly by LBNL, ORNL, and ANL in the summer of 1998 (36). A report detailing the recommendations of the working groups from this workshop is being prepared.

ACKNOWLEDGMENTS

The help of T. Barlow, C. Batson, P. Billquist, P. Decrock, A. Geraci, M. Kedzie, A. Ruthenberg, Dale L. Smith, and H. Zaim with several aspects of this work is appreciated.

This work is supported by the U. S. DOE Nuclear Physics Division under contract W-31-109-ENG-38.

The submitted manuscript has been authored by a contractor of the U. S. Government under contract No. W-31-109-ENG-38. Accordingly, the U. S. Government retains a nonexclusive, royalty-free license to publish or reproduce the published form of this contribution, or allow others to do so, for U. S. Government purposes.

REFERENCES

1. "The IsoSpin Laboratory, Research Opportunities with Radioactive Beams," LALP report 91-51 (1991).
2. "European Radioactive Beam Facilities," Report of the NuPECC Study Group (1993).
3. "Scientific Opportunities with an Advanced ISOL Facility," R.F. Casten, *et al.*, eds., November, 1997. (Available at <http://www.er.doe.gov/production/henp/isolpaper.pdf>).
4. Garrett, J. D., this conference.
5. Shepard, K. W., *et al.*, "Development of Niobium Spoke Cavities for a Superconducting Light-Ion Linac," Proceedings of the 1998 Linear Accelerator Conference, August 23-29, 1998, Chicago, IL.
6. Bollinger, L. M., *et al.*, Nucl. Instr. Methods **B79** (1993) 753.
7. Xie, Z. Q., Rev. Sci. Instr. **69** (1998) 625.
8. Gammino, S., this conference.
9. Donahue, R. J., *et al.*, "Radiation Problems in the Design of a Radioactive Nuclear Beam Facility," Proc. Specialists Meeting on Shielding Aspects of Accelerators, Targets, and Irradiation Facilities, Arlington, TX, April 28-29, 1994 (LBL-35459).
10. Moritz, L. E., Cyclotron Conf., Caen, France, June, 1998.
11. Schmor, P., this conference.
12. Hassanein, A., Journal of Nuclear Materials, **233-237** (1996) 1547.
13. Reed, C. B., Technology Development Division, ANL, private communication.
14. The LCS calculations and post-processing were carried out by I. C. Gomes, Technology Development Division, Argonne National Laboratory.
15. Gomes, I. C., Nolen, J. A., "Influence of the Incident Particle Energy on the Fission Product Mass Distribution," Proc. AccApp'98 (2nd International Topical Meeting on Nuclear Applications of Accelerator Technology), Gatlinburg, TN USA, September 20-23, 1998.
16. Nolen, J., "A Target Concept for Intense Radioactive Beams in the ^{132}Sn Region," Proc. Third Inter. Conf. On Radioactive Nuclear Beams, Ed. D. J. Morrissey, East Lansing, MI, May 24-27, 1993.
17. Kubo, T., *et al.*, Nucl. Instr. Meth., **B70** (1992) 309.
18. Dax, A., *et al.*, GSI Scientific Report 1997, GSI 98-1, p. 95.
19. Savard, G., *et al.*, Nucl. Phys. **A626** (1997) 353c.
20. Bjornstad, T., *et al.*, Z. Phys. A **303** (1981) 227.
21. Saint Simon, M. de, *et al.*, Phys. Rev. **C26** (1982) 2447.
22. Evensen, A. H. M., *et al.*, Nucl. Instr. Meth. In Phys. Res. **B126** (1997) 160.
23. Taylor, R.E., *et al.*, Thermophysical Properties Research Laboratory, Report 1825, March, 1997.
24. Bennett, J. R. J., this conf.
25. Talbert, W., this conf.
26. Ravn, H. L., "Sources for Production of Radioactive Ion Beams," Proceedings of the 1995 Particle Accelerator Conference, p. 858.
27. Lettry, J., *et al.*, Rev. Sci. Instr. **69** (1998) 761.
28. Ciavola, G., *et al.*, Nucl. Instr. Meth. In Phys. Res. **B126** (1997) 17.
29. Lunney, M. D., *et al.*, Report CSNSM 97-02, Orsay, 1997 (unpublished)
30. Decrock, P., *et al.*, Rev. Sci. Instr. **68** (1997) 2322.
31. Habs, D., *et al.*, Nucl. Instr. Meth. In Phys. Res. **B126** (1997) 218.
32. Marrs, R. E., Slaughter, D. R., "Charge State Boosting with a High Intensity Electron Beam Ion Trap," 15th Inter. Conf. on the Appl. of Accel. Res. and Industry, November 4-7, 1998, Denton, TX.
33. Geller, R., this conference.
34. Kaye, R. A., *et al.*, this conference.
35. Shepard, K. W., Kim, J.-W., "A Low-charge-state Injector Linac for ATLAS," Proceedings of the 1995 Particle Accelerator Conference, p. 1128.
36. "Experimental Equipment for an Advanced ISOL Facility," Workshop held at LBNL, Berkeley, CA, July 22-25, 1998.