

# CHEMISTRY OF CARBON IN DYNAMIC SODIUM

F. LIEVENS, F. CASTEELS,  
SCK/CEN,  
Mol, Belgium

## ABSTRACT

*The chemistry of carbon in sodium is described by its chemical activity measurements using alloy monitor foils, by its behaviour in the heat exchanger of the Na 2 sodium loop after 60 000 hours of operation, and by measurements with on-line meters. Efforts toward the identification of the carbon chemical states present in dynamic sodium, and responsible for the carbon chemical activity are described.*

## Introduction

The transfer of carbon in dynamic sodium is a wellknown phenomenon. In systems built from one material, carbon is released in the sodium stream at the higher temperatures, and deposited from the sodium at lower temperatures either as elemental carbon or in combination with other elements. In multimetallic systems, rate and direction of carbon transfer depend also on the carbon activity in the different alloys. This activity is a function of temperature, composition and carbon content of these alloys.

More difficult is the quantitative prediction of carbon transfer rate, and the intensity and depth of carburization or decarburization of the structural materials. The experiments described here will be restricted to the carbon behaviour in the sodium. Implicit in this description is the subdivision of the carbon transfer into : a take-up or deposition of carbon by the sodium governed by the chemical activity of carbon in the sodium with respect to the activity at the surface of the structural material, and the behaviour of the carbon in the alloy.

Two quantities need to be measured. First the carbon activity which is the driving force for carbon transfer. Next comes the total amount of carbon available in the sodium and which will become active if carbon is picked-up by the structural materials. The chemical forms under which the total amount of carbon is present in the sodium, and the transformation kinetics are interesting, but difficult subjects.

In this paper we will first give activity measurements obtained with monitor alloys and with carbon on-line meters. The carbon transfer in a heat exchanger will be given next as a general description of carbon transfer in a temperature gradient. Finally efforts to identify the chemical states of carbon will be described.

## Activity determination with monitor foils

In this method thin foils are exposed to dynamic sodium in the temperature range between 550 °C and 730 °C. The sodium mass flow rate over the exposed foils was in the range of 0.04 l.s<sup>-1</sup> to 0.35 l.s<sup>-1</sup>, depending on the sodium loop and experimental set up used. The time of equilibration is a function of alloy composition, temperature, and foil thickness, and has been derived from the diagram published by Natesan and Kassner (1).

The cleaning before exposure consists in degreasing with acetone, ultrasonic cleaning in ethyl alcohol and drying in hot air. The cleaning after exposure to sodium consists in removal of the residual sodium in water, immersion in alcohol, and drying in hot air. The carbon determination is carried out by destructive combustion with an induction furnace and measurement of the Carbon oxides evolved. The corresponding activities have been calculated using the relationships derived by Bodworth (2), and Natesan (3).

- 
- (1) K. NATESAN  
Nuclear Technology 19, (1973), 46-57.
  - (2) C. BODSWORTH,  
Transactions of the metallurgical society of AIME 242, (1968), 1135-1142.
  - (3) K. NATESAN, T.F. KASSNER,  
Metallurgical Transactions, 4, (1973), 2557-2566.

XA0200948



The alloys used are given in table I. The foil thickness is 50 to 100  $\mu\text{m}$  for iron nickel, and iron manganese alloys, and 25 to 50  $\mu\text{m}$  for the AISI 304 (OEW 202 and OEW 201) alloys.

The experiments have been carried out to determine the influence on the carbon activity of cold trap temperature, of the maximum loop temperature, and of the temperature gradient in the loop. Another set of experiments was aimed at the influence of the exposure temperature of the foils.

For the first study three maximum temperature of the loop, namely 550  $^{\circ}\text{C}$ , 600  $^{\circ}\text{C}$  and 650  $^{\circ}\text{C}$ , and cold trap temperatures varying between 120  $^{\circ}\text{C}$  and 180  $^{\circ}\text{C}$  were used. The cold leg temperature was maintained at 380  $^{\circ}\text{C}$ .

In the second study the activity was measured by exposure of foils at 730  $^{\circ}\text{C}$  and 550  $^{\circ}\text{C}$  simultaneously.

The results of these experiments are given in table II and III. It can be concluded that for maximum temperatures in the loop between 600  $^{\circ}\text{C}$  and 650  $^{\circ}\text{C}$ , the carbon activity increases with increasing cold trap temperature. The activity increases also at constant cold trap temperature with decreasing maximum temperature in the loop. This is most apparent below 600  $^{\circ}\text{C}$ .

The results obtained as a function of exposure temperature, show higher carbon activities at low temperature. The activity at 550  $^{\circ}\text{C}$  being 3 to 10 times larger than at 730  $^{\circ}\text{C}$ . Also two phase alloys (OEW 201) give rise to larger values when compared with the results obtained with single-phase alloys.

If the activity of carbon and the carbon solubility are used to calculate the concentration of the active carbon all values found are within 0.02 ppm and 0.2 ppm and are mostly near 0.05 ppm. This observation points to slow kinetics for the active carbon which remains at a constant concentration and displays an activity varying with its solubility when the temperature of the sodium is changed.

Chemical analyses on the sodium during these experiments are given in table IV. The chemical forms detected are at much too high levels to allow the identification of the active species.

#### Activity survey with on-line meters

Off-line chemical analyses and monitor tabs do not allow to follow the evolution of the carbon activity, because the loop must be opened at frequent intervals causing uncontrolled contamination of the sodium. On small loops like

ASL which contains approximately 75 litres, contaminations as high as 20 ppm carbonate have been occasionally observed. On-line carbon meters avoid this inconvenient, and have been used to follow activity changes on ASL. The general trend of the signal from these meters is a slow decrease in carbon activity. Changes in cold trap temperature are reflected in the carbon activity displayed by the on-line meters.

On the Mass spectrometric carbon meter, the Masses 12, 16 and 28 showed a daily decrease of 3 %. Raising the cold trap temperature from 150 to 180  $^{\circ}\text{C}$  decreased the signal by  $\sim 30$  %.

A further decrease of  $\sim 20$  % is observed when the cold trap temperature was changed from 180  $^{\circ}\text{C}$  to 220  $^{\circ}\text{C}$ .

#### Carbon transfer in a heat exchanger

Carbon transfer in a temperature gradient is best observed in a sodium-sodium heat exchanger. From the detailed post corrosion analysis of an AISI 316 L sodium-sodium heat exchanger after 60 000 hours of operation on Na 2 loop between 680  $^{\circ}\text{C}$  and 240  $^{\circ}\text{C}$  the carbon profiles are given in fig. 1. The surface carbon concentration is given in fig. 2. The temperature distribution and schematic representation are given in fig. 3 (4).

It can be seen that, in the upstream, most of the carbon is deposited above 450  $^{\circ}\text{C}$ . In the downstream deposition is highest at the highest temperatures and is apparently related to the solubility of carbon in sodium.

Two theoretical models (5)(6) have been tested on this carbon transfer, and their results plotted in figure 2. The ANL model gives the best fit in the upstream carbon deposition.

- 
- (4) F. CASTEELS, H. TAS, J. DRESSELAERS, A. COOLS and L. KNAEPEN  
Proceedings, International Conference on Liquid Metal Technology in Energy  
Production, Champion, 3-6 May 1976, 577-583.
- (5) A. SHIELLS et Al.,  
Nuclear Technology, 23 (1974), 273-284.
- (6) R.B. SNIJDER,  
Journal of nuclear materials 50 (1974) 269-274.

## Analysis of carbon chemical forms

Carbon chemical states in sodium have been searched by off-line chemical analysis. During the first year of operation of the Analytical Sodium Loop, carbonates, cyanides, carbonyls and carbides have been identified in the sodium from the loop. The amounts found are low and do not represent the total carbon as shown in table V giving the results of some of these analyses. The term residual carbon covers all carbon forms which are not volatile after hydrolysis and acidification, and which are not eliminated by evaporating the water contained in the resulting sodium sulphate solution, before oxidation with "van Slycke" reagents. Good candidates for residual carbon are elemental carbon, graphite and refractory metal carbides.

The maximum loop temperature has been indicated to show that when the temperature is kept below 400 °C, most of the carbon is residual carbon. Carbides are most abundant between 400 and 600 °C. Cyanides are found at higher temperatures. Carbonate results from atmospheric contamination during the sampling operations, and are therefore erratic.

Sampling of sodium for carbon analysis has proved to be irreproducible. Large deviations are sometimes observed on sodium samples taken as duplicates in the same sampler. Since all the determinations are not carried out on the same sodium portions, the total carbon obtained by the combustion method is not the exact sum of the chemical forms.

The experiments 1 to 6 were purifications on the sodium by dumping and cold trapping. It can be seen from the total carbon that cold trapping is inefficient for carbon. Operation at higher temperatures than 400 °C result in transformation of the carbon chemical states and deposition somewhere in the loop. Taking into account the carbon solubility, this deposition will happen in sections at 400 to 550 °C. The carbon profiles in the heat exchanger supports this assumption.

The composition of the carbides has been analysed by gas chromatography and some results are given in table VI. It is surprising to find such large molecules as  $M_8C_3$  and  $M_8C_4$ . During the hydrolysis of the sample to give sodium hydroxide, hydrocarbons and hydrogen, it is not impossible that the hydrocarbons are modified. But the supposition that the higher hydrocarbons are condensations of acetylene and hydrogen, is not supported by these results ; because there is no correlation between the amount of acetylenide and the other hydrocarbons.

## Conclusions

From chemical analyses it is known that carbon is present in sodium in several chemical forms. Among these forms Carbonate, Carbonyl, Cyanide, Six carbides, and residual or refractory form have been identified. These carbon compounds are relatively stable below 400 °C and will therefore not contribute significantly to carbon mass transfer, at low temperatures. At higher temperatures like 500 to 600 °C some transformation and carbon activity is to be expected.

From the solubility curve of carbon in sodium it may be expected that carbon mass transfer will be located in the temperature range above 360 °C. In this range significant amounts of carbon can be accepted by the sodium. The increase in solubility with temperature rise is large and transfer phenomena will make the temperature range above 500 °C dangerous, for structural materials.

TABLE I : Composition of monitor alloys (as received)  
Concentration in wt %

ALLOY	DEW 202	DEW 201	Fe 8 Ni	Fe 20 Ni	Fe 12 Mn	Fe 20 Mn	Fe 30 Ni
C	0.0535	0.046	0.0066	0.0062	0.0040	0.0273	0.0080
N	0.0424	0.041	0.0096	0.0028	0.0091	0.0142	0.0070
Cr	18.18	18.04	0.0025	0.0025	0.0025	0.0050	0.0050
Ni	8.33	8.49	8.11	20.4	0.0050	0.0050	30.2
Mn	0.91	1.12	0.0050	0.0050	11.2	19.0	0.0050
Mo	0.30	0.15	0.0025	0.0025	0.0025	0.0050	0.0050
Co	0.17	0.07	0.0025	0.0025	0.0025	0.0025	0.0025
W	0.04	0.01	-	-	-	-	-
V	0.04	0.05	-	-	-	-	-
Cu	0.16	0.16	0.0100	0.0075	0.0050	0.0075	0.0075
S	0.03	0.011	-	-	-	-	-
P	0.034	0.023	-	-	-	-	-
Si	0.39	0.56	0.0100	0.0100	0.0100	0.0100	0.0100
Nb	0.09	0.03	-	-	-	-	-
Ti	0.01	0.01	0.0100	0.0100	0.0100	0.0200	0.0200
Sn	-	-	0.0050	-	0.0025	0.0100	0.0100
Ca	-	-	0.0025	0.0025	0.0025	0.0025	0.0025
Pb	-	-	-	-	-	0.002	-

EXPERIMENT	COLD TRAP TEMPERATURE (°C) (HOURS AT COLD TRAP TEMP.) T <sub>2</sub>	EXPOSURE TEMPERATURE (°C) T <sub>1</sub>	TIME (h)	Fe & Ni	CARBON ACTIVITY MEASURED BY SYSTEM Fe 12 Mn	DEW 202 (HEAT TREATED)
1	120	650	206	2.3 10 <sup>-3</sup>	3.25 10 <sup>-3</sup>	5.28 10 <sup>-3</sup>
2	180	651	206	2.8 10 <sup>-3</sup>		
4	180	660	206			
6	120 (140 h) - 129 (26 h)	600	166	4.2 10 <sup>-3</sup>		
8	138 (140 h) - 150 (26 h)	600	166	7.1 10 <sup>-3</sup>		
10	150	600	882	2.6 10 <sup>-3</sup>		3.01 10 <sup>-3</sup>
11	150	550	300	5.35 10 <sup>-3</sup>		DEW 201 (as received) 5.32 10 <sup>-3</sup>
12	150	543	300	Fe 20 Ni	→ 1.51 10 <sup>-2</sup>	3.89 10 <sup>-3</sup>
"				Fe 20 Mn	→ 3.45 10 <sup>-2</sup>	7.8 10 <sup>-2</sup>
"				Fe 12 Mn	→ 2.03 10 <sup>-2</sup>	
15	120	530	937	Fe 20 Ni	→ 9.66 10 <sup>-3</sup>	2.04 10 <sup>-2</sup>
19	120	530	600	WARD monitor	→ 5.42 10 <sup>-3</sup>	1.62 10 <sup>-2</sup>
20	120	530	600	Hanford monitor	→ 6.44 10 <sup>-3</sup>	1.40 10 <sup>-2</sup>

TABLE II :

Experimental conditions and measured carbon activities

EXPERIMENTAL CONDITIONS. EXPOSURE TIME AND COLD TRAP TEMPERATURE	SYSTEM	CARBON ACTIVITY AT 730 °C	SYSTEM	CARBON ACTIVITY AT 550 °C
25 h at 180 °C	Fe 20 Ni	1.17 10 <sup>-2</sup>	Fe 20 Ni	3.71 10 <sup>-2</sup>
	DEW 201 (10'/1040 °C)	1.57 10 <sup>-2</sup>	Fe 30 Ni	5.32 10 <sup>-2</sup>
50 h at 180 °C	Fe 20 Ni	1.79 10 <sup>-2</sup>	Fe 20 Ni	5.84 10 <sup>-2</sup>
	DEW 201 (10'/1040 °C)	3.28 10 <sup>-2</sup>	Fe 30 Ni	5.99 10 <sup>-2</sup>
100 h at 180 °C	Fe 20 Ni	1.87 10 <sup>-2</sup>	Fe 20 Ni	3.26 10 <sup>-2</sup>
	DEW 201 (10'/1040 °C)	2.15 10 <sup>-2</sup>		
200 h at 180 °C	Fe 20 Ni	8.27 10 <sup>-3</sup>	Fe 20 Ni	3.79 10 <sup>-2</sup>
	DEW 201 (10'/1040 °C)	1.75 10 <sup>-2</sup>	Fe 30 Ni	4.79 10 <sup>-2</sup>
100 h at 120 °C	Fe 20 Ni	5.6 10 <sup>-3</sup>	Fe 20 Ni	2.04 10 <sup>-2</sup>
	DEW 201 (10'/1040 °C)	2.89 10 <sup>-3</sup>		
100 h at 220 °C	Fe 20 Ni	6.67 10 <sup>-3</sup>	Fe 20 Ni	8.43 10 <sup>-2</sup>
	DEW 201 (10'/1040 °C)	1.37 10 <sup>-2</sup>	Fe 30 Ni	8.88 10 <sup>-2</sup>

TABLE III :

Carbon activity measurements carried out at 730 °C and 550 °C (during single experiment)

TABLE IV : Sodium analyses (ppm)

EXPERIMENT	OXYGEN CONTENT	CARBON CONTENT				
		TOTAL CARBON	CARBIDES	CARBONYL	CARBONATE	CYANIDE
1	0.64 - 0.55	5.02	0.44	1.79	3.10	
2	27.76	5.70	0.88	1.36	3.19	< 0.01
6	3.55	2	0.13	2.56	1.92	
	6.7	3.7	0.16	2.26	1.74	
8	6.7 - 8.2	not determined				
10	4.98	10.9	0.66	9.12	2.82	0.09
12	25	10	0.59	2.58		
15	22.9	18.1	0.76	7.68	8.11	
			0.04	6.62	0.31	

EXPERIMENT	TOTAL CARBON	CARBIDES	CARBONATE	CARBONYL	CYANIDE	RESIDUAL	MAXIMUM LOOP TEMPERATURE
1	15.1	0.12	< 0.16	-	-	9.0	400 °C
2	7.1	0.12	< 0.04	-	-	8.1	400 °C
3	5.2	-	< 0.37	-	-	11.3	400 °C
4	6.0	-	< 0.19	-	-	7.5	400 °C
5	17.3	-	1.73	-	-	11.3	400 °C
6	7.7	0.32	2.1	0.3	-	2.7	400 °C
7	11.0	3.5	20.2	1.16	< 0.01	-	400 °C
8	3.3	5.0	5.15	1.25	< 0.01	-	550 °C
9	5.8	2.7	0.71	2.64	0.045	-	500 °C
10	4.0	2.3	2.72	1.3	0.05	-	600 °C
11	0.91	0.48	1.83	0.46	0.44	-	675 °C
12	2.6	0.4	9.9	0.42	0.09	-	675 °C

TABLE V :

Chemical forms of carbon in sodium (expressed as ppm carbon)

TABLE VI : Hydrocarbons obtained after hydrolysis of sodium  
(in ppm carbon in sodium)

EXPERIMENT	1	2	6	8	11
$C_2H_2$	0.012	0.013	0.21	0.040	0.054
$C_2H_4$	0.022	0.023	0.039	0.020	0.015
$C_2H_6$	0.047	0.038	0.037	0.018	0.017
$C_3H_6$	0.018	0.028	0.028	0.018	0.010
$C_3H_8$	0.022	0.019	< 0.01	< 0.01	< 0.01
$C_4H_8$	< 0.01	< 0.01	< 0.01	0.029	0.042

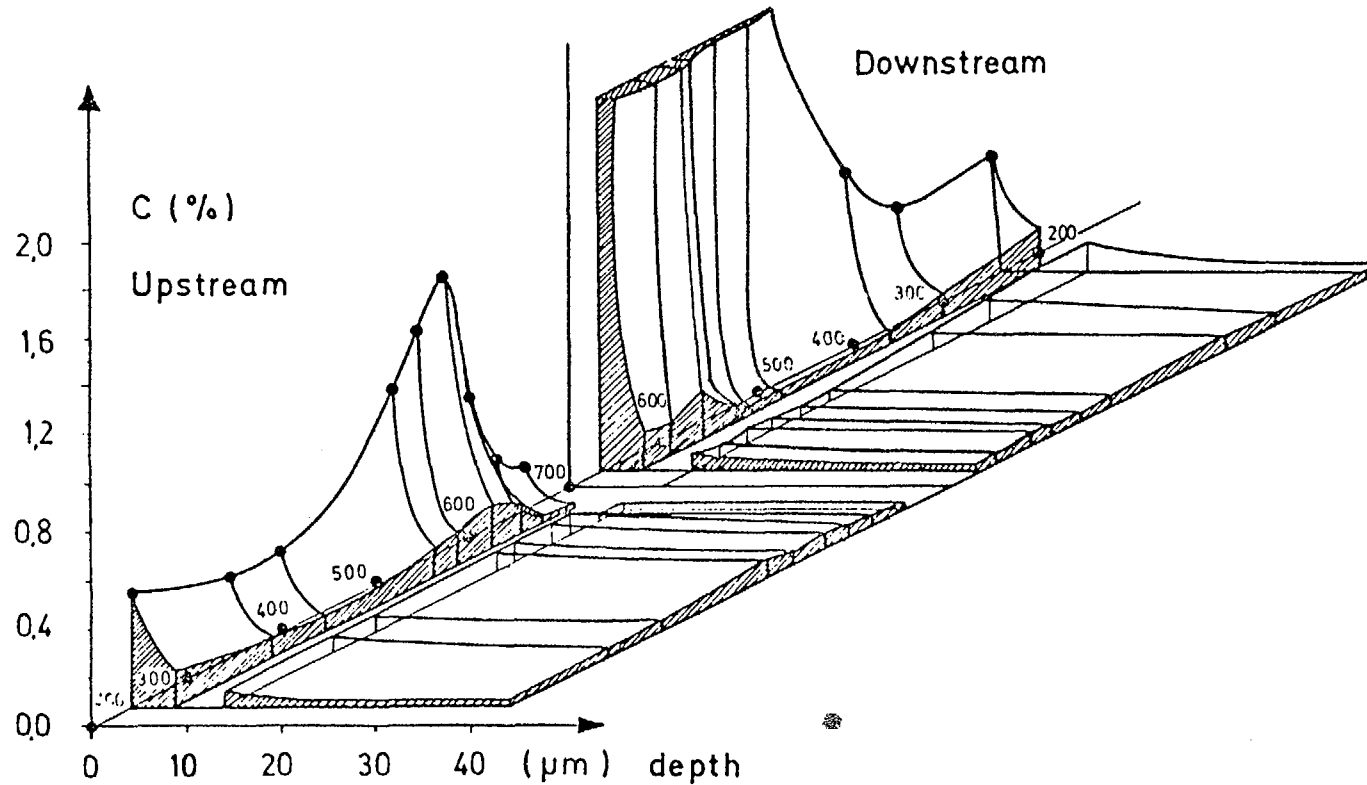
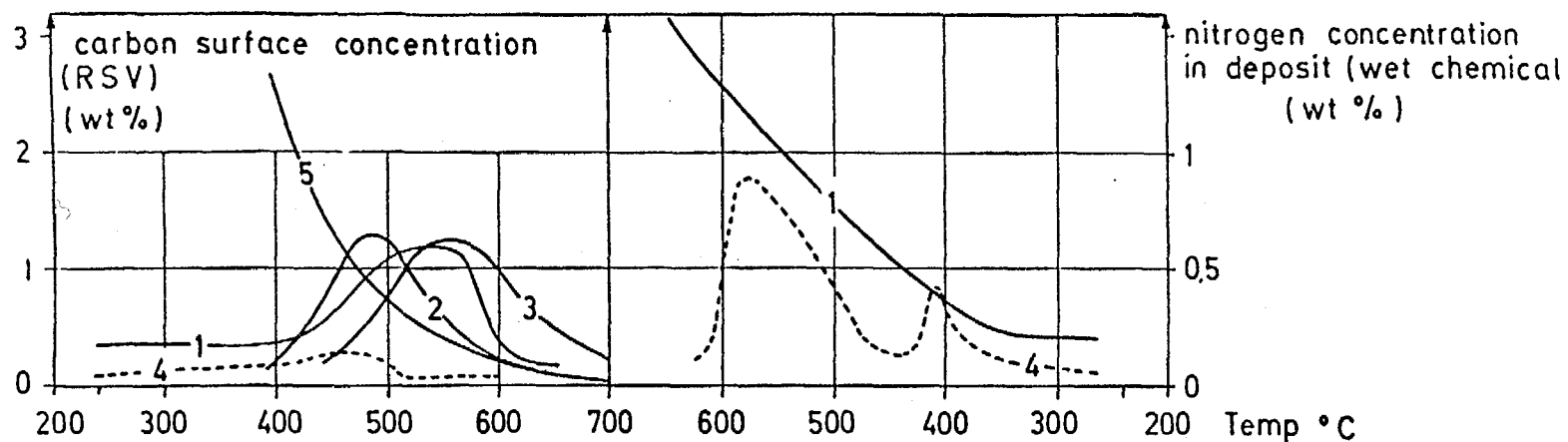

Fig.1 . : Measured carbon surface concentration and penetration depth  
versus temperature relationship in up- and downstream positions.



(1) carbon, experimental

Carbon, calculated according to ANL model (0.2 ppm C in Na)

(2) 700 °C max; 60,000 h

(3) 600 °C max; 60,000 h

(4) nitrogen experimental

(5) carbon, calculated according to WARD model ( $C_S = 600$  ppm C)

(c)

Fig. 2. : Dependence as a function of temperature and experimental determined surface concentrations of carbon and nitrogen or calculated by the WARD and ANL method

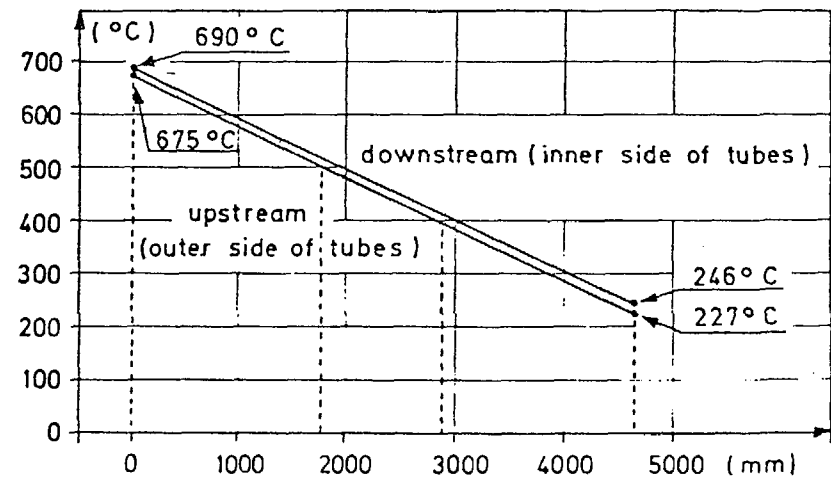
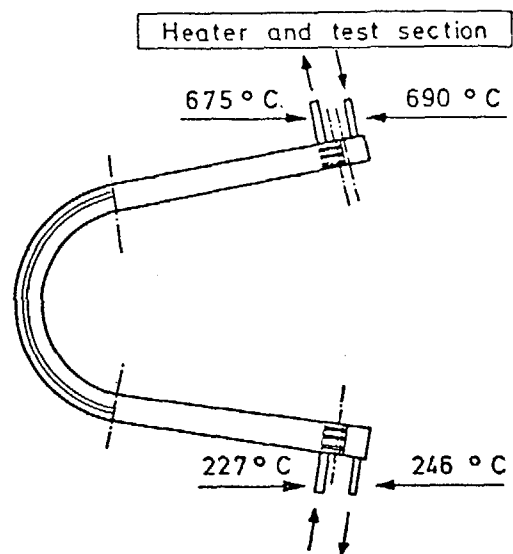

(a)

Na-Na recuperator 60.000 hours operation, test section at 700 °C. (b)

Fig. 3 : Temperature distribution (b) and schematic representation (a) of the examined Na-Na recuperator