



XA04C1610

CONSTRUCTION OF THE UPGRADED JRR-3

**S. Matsuura, E. Shirai, and
N. Onishi**

Construction of the Upgraded JRR-3

Shojiro MATSUURA, Eiji SHIRAI and Nobuaki ONISHI

Japan Atomic Energy Research Institute,
Tokai-mura, Ibaraki-ken,
Japan

ABSTRACT

The construction of the upgraded Japan Research Reactor No.3 (JRR-3) has almost completed. The old reactor was removed from the reactor room, and the new reactor is reconstructed at the place where the old core was. The upgraded reactor is a pool type, 20MW(th), light water moderated and cooled, beryllium and heavy water reflected. Fuels are 20% low enriched UAl_x -Al(LEU) plate type as part of the international Reduced Enrichment for Research and Test Reactors (RERTR) program. Maximum thermal and fast flux are expected to be more than 2×10^{14} n/cm²s. The upgraded JRR-3 has several beam experimental holes and irradiation facilities for multipurpose utilization, including a cold neutron source facility.

1. INTRODUCTION

The old JRR-3 was the first domestically constructed reactor in Japan. It had been operated for 21 years and was shut down in 1983 for upgrading. Only the reactor building, the spent fuel storage room and the fresh fuel storage facility are reused, but every other facility and building are newly constructed. So we can say this upgraded reactor is essentially new one¹⁾.

2. REMOVAL OF OLD REACTOR

The main body of the old reactor consisting of a core tank, graphite reflector, thermal shield tank and biological shield, was removed by the one-piece-removal method²⁾. The body was about 2200ton in total weight. It was separated from the reactor room floor by means of continuous core boring, and transferred to the large scale waste storage room. This body will be kept under close observation for a long time. This method has an advantage that the spread of the radioactive waste is avoided. As this is an established technique in the construction industry field, it was carried out

in safety. This is the first time for this method to try in the nuclear field.

3. REACTOR FACILITIES

The upgraded JRR-3 is a pool type reactor and the thermal power is 20MW. The depth of the pool is about 8m and the cylindrical core is submerged in light water. The diameter of the core is 0.6m and the height is about 0.75m. Its specific power is rated at 156 kW/l. The fuel is MTR type (UAl_x -Al dispersion fuel) with an enrichment of 20wt%. There are two types of fuel elements, a standard fuel element and a follower fuel element. They have 300g ^{235}U and 190g ^{235}U , respectively. The neutron absorbing control rod is made of hafnium and connected to a follower fuel element.

The heavy water tank, as a reflector, is a double cylindrical type aluminum vessel. Its outer diameter is about 2m and height is about 1.6m. Irradiation thimbles, horizontal beam tubes and a cold neutron source are installed in this tank.

The operation cycle length will be 5 weeks, 4 weeks for a 20MW operation and 1 week for a shutdown work. Nine cycles are scheduled in a year and the operating efficiency will be about 70%.

4. EXPERIMENTAL FACILITIES

Nine horizontal beam tubes (1G-6G,7R,8T,9C) are arranged tangentially to the reactor core. Six tubes (1G-6G) are ready for the neutron scattering facilities in the reactor hall. 7R is for the neutron radiography facility.

There is one cold neutron source (CNS) on 9C. It is a vertical thermosiphon type and the moderator is liquid hydrogen at about 21K. The gain of this CNS is estimated to be more than 5 for neutrons of 5meV (wavelength is 4\AA).

Two thermal and three cold neutron guide tubes are installed in the beam hall which is 30m width and 50m length. Their neutron mirrors are natural nickel sputtered borosilicate glass. The longest guide tube is about 60m and the total length is about 230m.

5. SOME FEATURES ON DESIGN

The design of the upgraded JRR-3 has much contrivance. Some of them are as follows. 1) Maximum thermal and fast flux is rather high with low

enriched fuels. 2) Horizontal beam tubes are arranged tangentially to the reactor core center. 3) The cooling system and the ^{16}N decay tank is designed very compactly to be stored in the old building. 4) The emergency exhaust system will ventilate the reactor room through a charcoal filter in accident conditions. 5) Two siphon break valves are installed independently on the primary cooling pipe to prevent the loss of coolant (pool water).

6. CONCLUDING REMARKS

The installation of the upgraded JRR-3 has finished and it will be critical in March, 1990. After the half year characteristic test, full power operation will start in October.

This upgraded JRR-3 will meet the expectations of scientists and engineers by its increasing experimental ability.

REFERENCES

- [1] N.Onishi et al., Proc. Int. Symp. on the Utilization of Multipurpose Research Reactors and Related International Co-operation, (IAEA,Vienna, 1988) p.79, IAEA-SM-300/2.
- [2] N.Onishi et al., Proc. Int. decommissioning Symp., (Pittsburg, 1987) VI-95, CONF-871018-Vol.1.

History of JRR-3

Year	Major Events	Year	Major Events
1959	Beginning of JRR-3 construction	'76	
'60		'77	
'61	Reactor completion	'78	Integrated power 300,000 MWII achieved
'62	Reactor critical	'79	
'63		'80	
'64	Rated power 10,000 KW achieved	'81	
'65	Beginning of RI production	'82	The twentieth anniversary since the reactor critical
'66	Beginning of common use	'83	Close of common use
'67	Beginning of homemade fuel use	'84	Finish of safety review for new JRR-3
'68		'85	Beginning of the construction work for new JRR-3
'69	Medical irradiation for a brain tumor	'86	↑
'70		'87	Construction
'71	Sample irradiation of nuclear fuel in LITL	'88	↓
'72	Beginning of shift to UO ₂ fuel core	'89	
'73		'90	Completion of new JRR-3
'74	Integrated power 200,000 MWII achieved		
'75	Completion of shift to UO ₂ fuel core		

Total operation time : 47,137 hrs 39 min
Total integrated power : 419,073.5 MWII

Isometric View of Reactor Pool

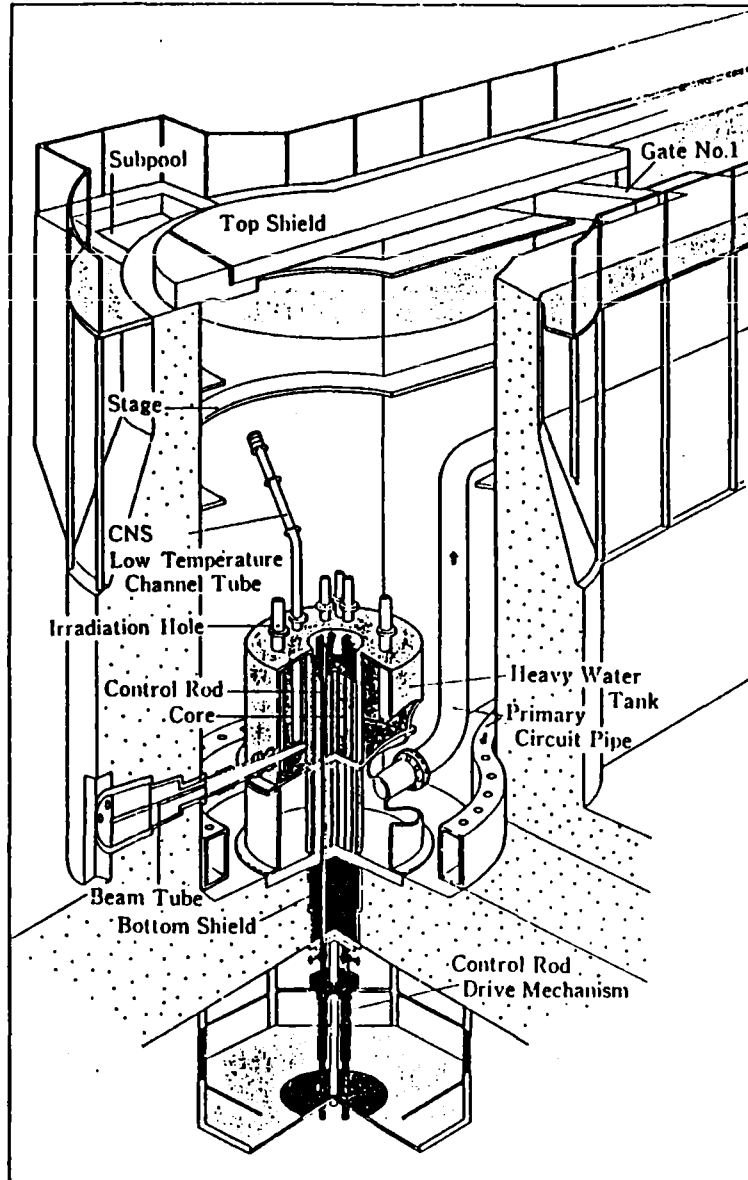

REACTOR

Major Specifications of the New JRR-3

Reactor Type	Low Enriched Uranium, Light Water Cooled and Moderated, Swimming Pool Type.
Rated Power	20 MW
Size of Core	Approx. 60cm dia. and 75cm high (with Beryllium Reflector).
Fuel	UAlx-Al Dispersed, MTR Plate Type 20% Enriched Fuel. 26 Standard Fuel Elements and 6 Follower Fuel Elements.
Control Rod	6 Control Rods, Box Type Absorber, followed with Follower Fuel Element.
Reactor Pool	Swimming Pool Type 4.5m dia. 8.5m deep
Experimental Facilities	9 Horizontal Beam Tubes, 17 Vertical Irradiation Holes, and 1 Cold Neutron Source

CONCEPT OF ONE PIECE REACTOR REMOVAL

Cross Section

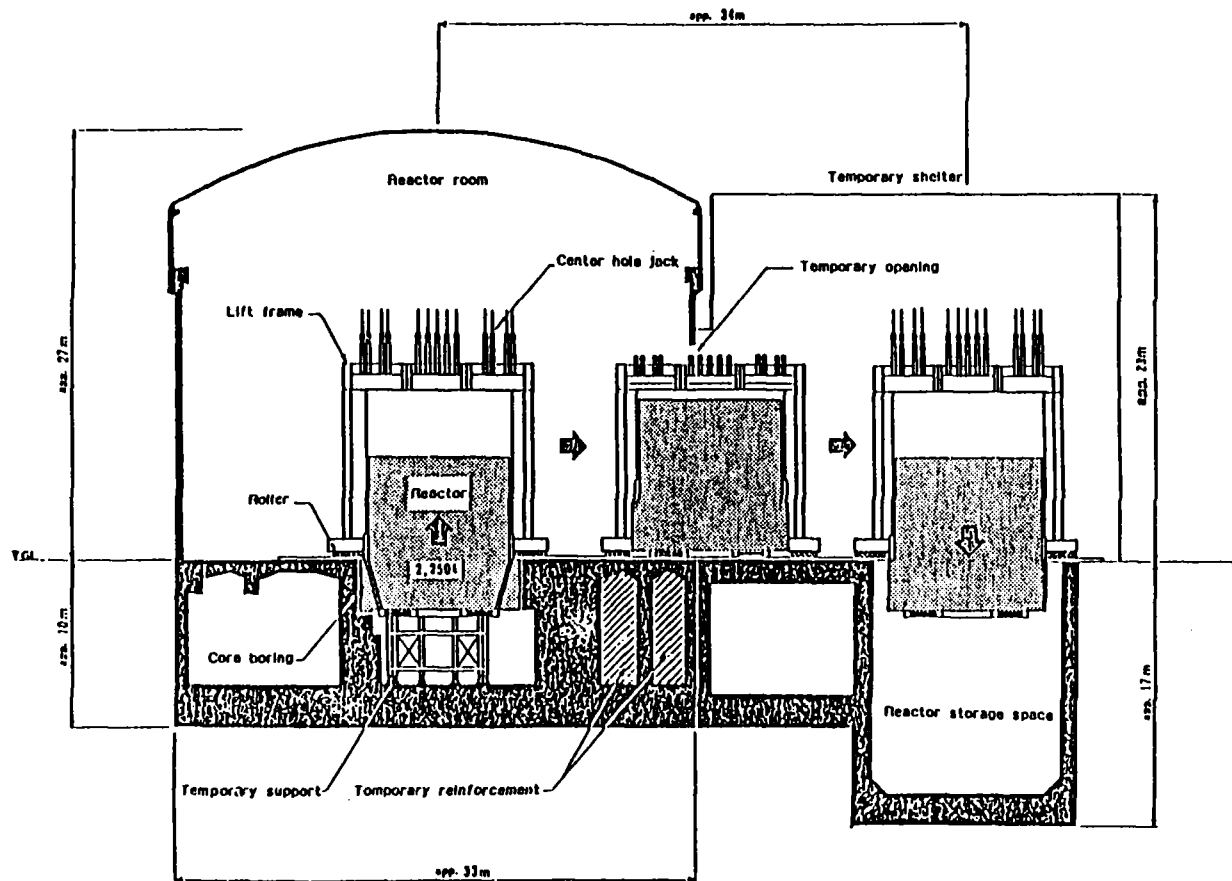

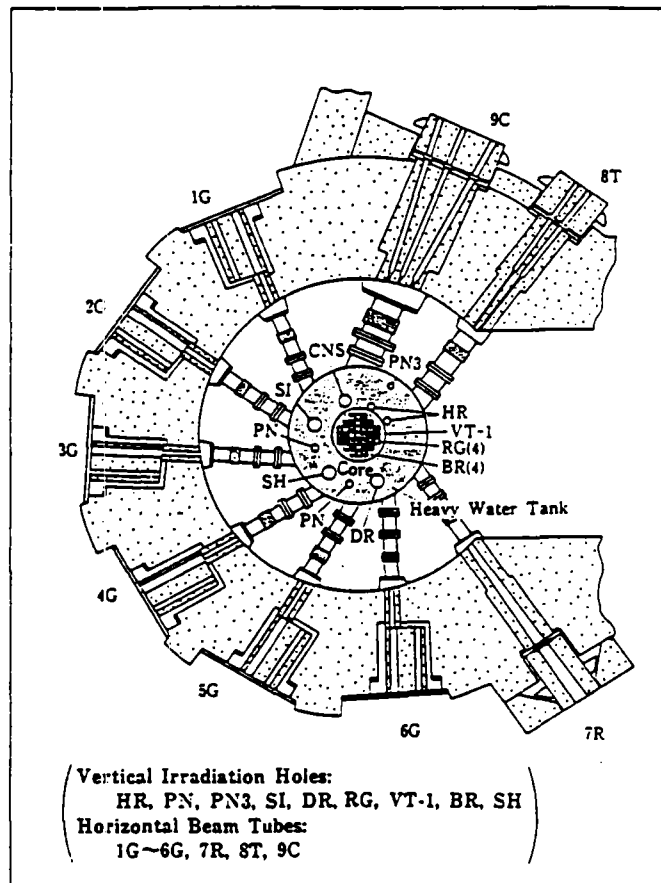

Arrangement of Experimental Holes

Summary

Name	No	Application	Feature
Hydraulic rabbit irradiation facility (HR)	2	General irradiation Radioisotope production	The rabbit is conveyed and cooled by water. This facility is used to irradiate the relatively heavy and high heat generating samples.
Pneumatic rabbit irradiation facility (PN)	2	General irradiation Radioisotope production	The rabbit is conveyed and cooled by N_2 gas. This facility is used to irradiate the light and low heat generating samples.
Activation analysis irradiation facility (PN3)	1	Activation analysis of the short life radio nuclides	The radiation measurement is started immediately after the irradiation. This facility is used to analyze the short life radio nuclides.
Uniform irradiation facility (SI)	1	Material irradiation Silicon irradiation	The sample is rotated and moved up and down during the irradiation. This facility is used to irradiate the sample uniformly.
Rotating irradiation facility (DR)	1	Large material irradiation	The sample is rotated during the irradiation. This facility is used to irradiate the sample uniformly in the radial direction.
Capsule irradiation facility (RG, BR, VT-1, SH)	10	Exposure test Radioisotope production	This facility is used to irradiate for long period or control the sample temperature in response to the irradiation condition.

Standard Fuel Element

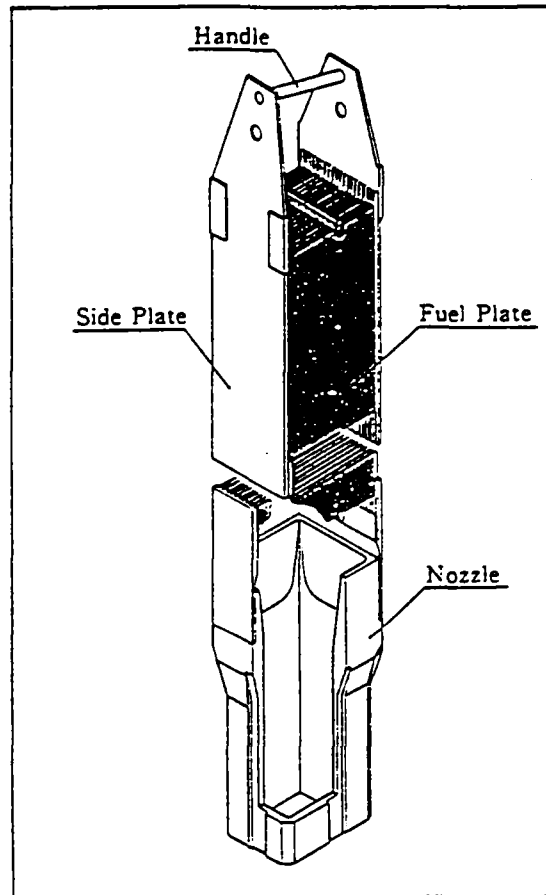

Summary of Fuel Specification

Item	Standard Fuel Element	Follower Fuel Element
Size of Fuel	76 × 76 × 1150mm	64 × 64 × 880mm
U-235 Enrichment	20%	20%
U-235 Contents	300g	190g
Size of Fuel Plate	1.52' × 71" × 770 ^L mm	1.52' × 60" × 770 ^L mm
Fuel Plate Number	20/Element	16/Element
Fuel Meat Material	Dispersed UAlx-Al	
Cladding Material	Aluminium Alloy	
Maximum Burn-up	50% (on the average)	

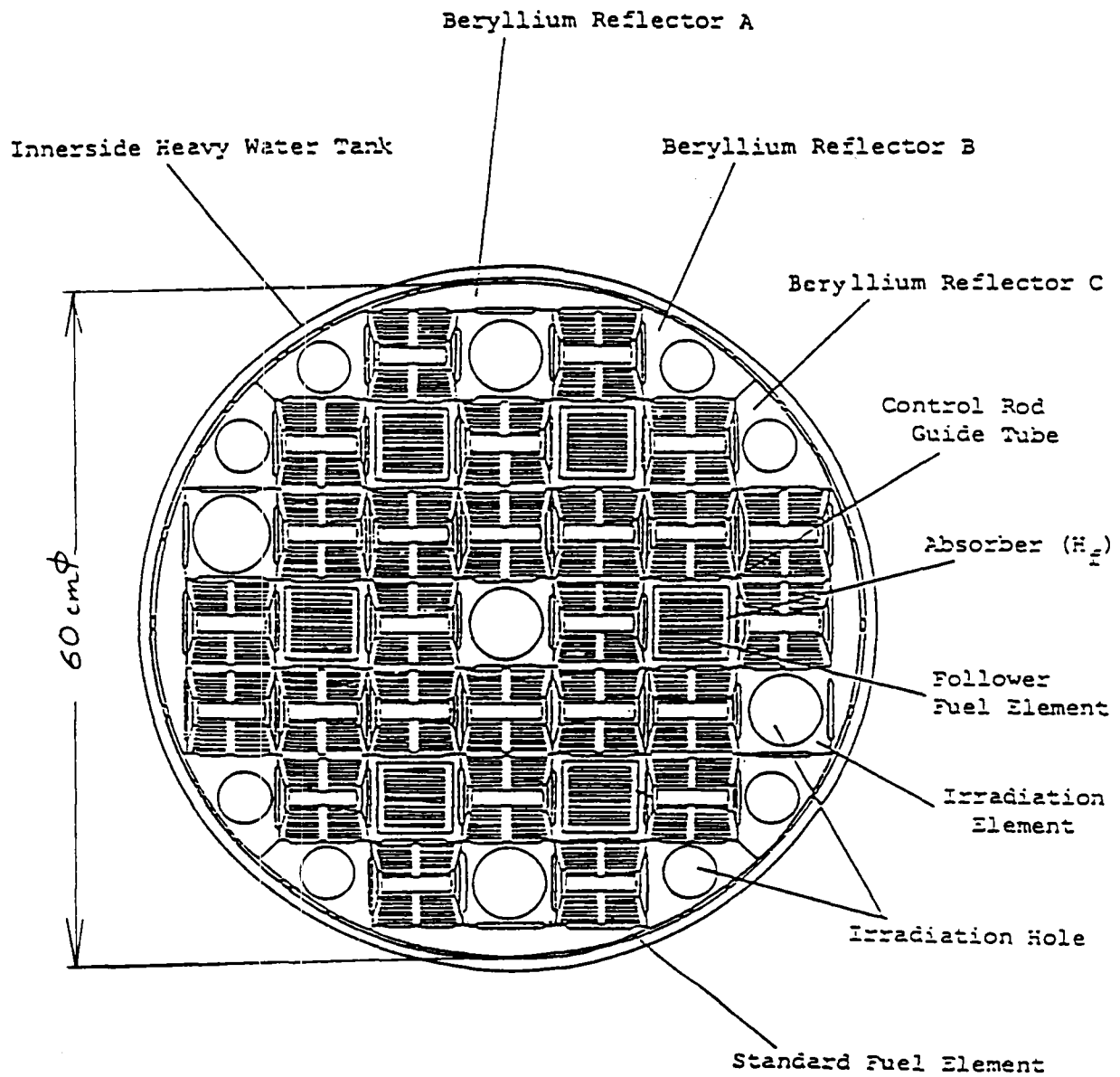

Horizontal Section of Reactor Core

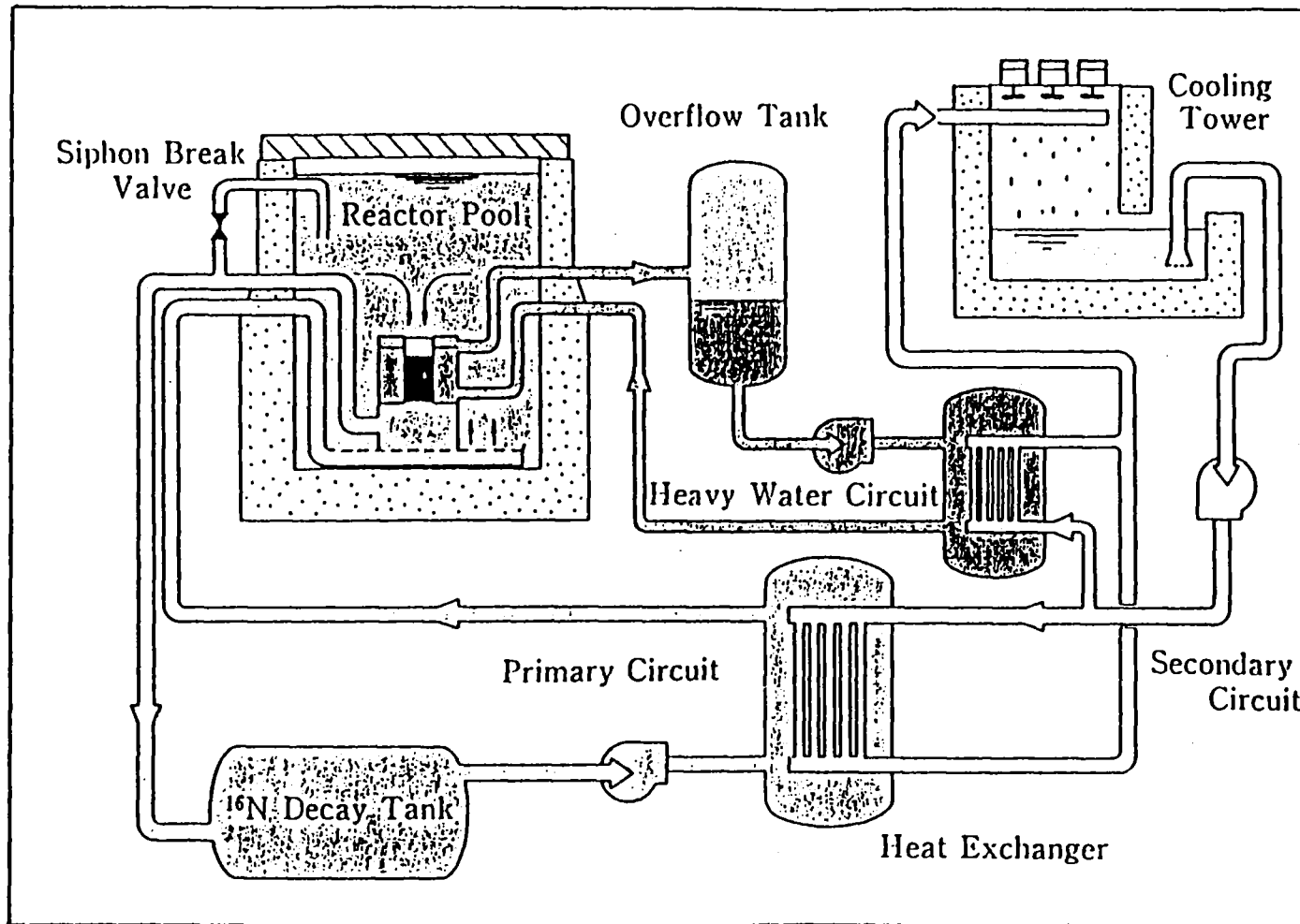

Flow Diagram of Cooling Systems

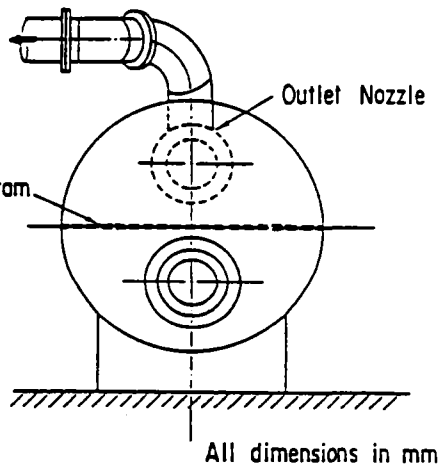
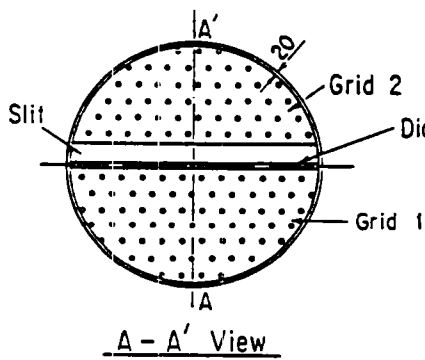
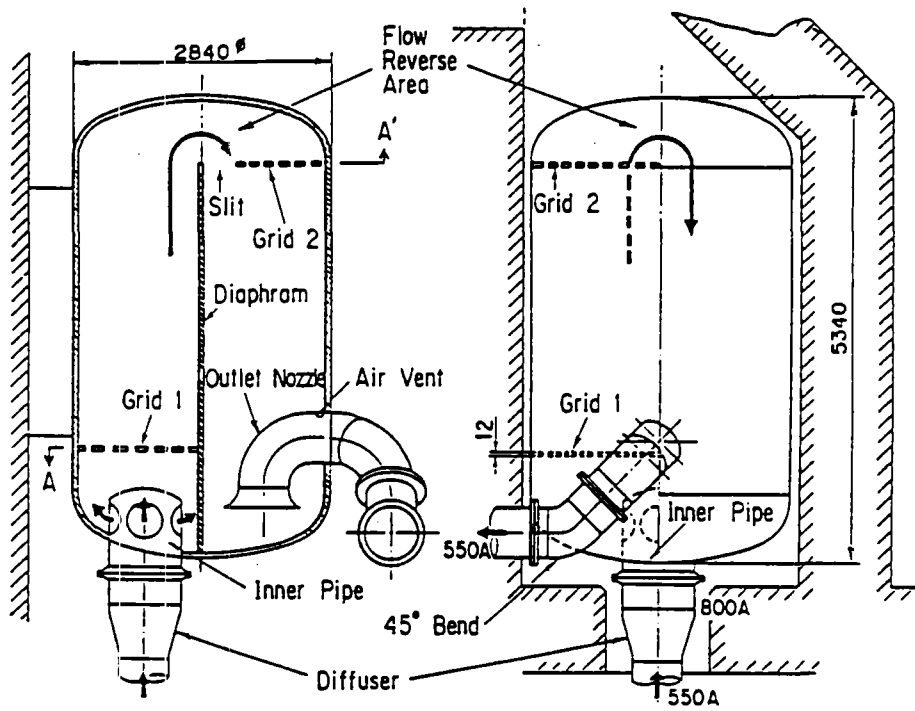

Description of ^{16}N Decay Tank

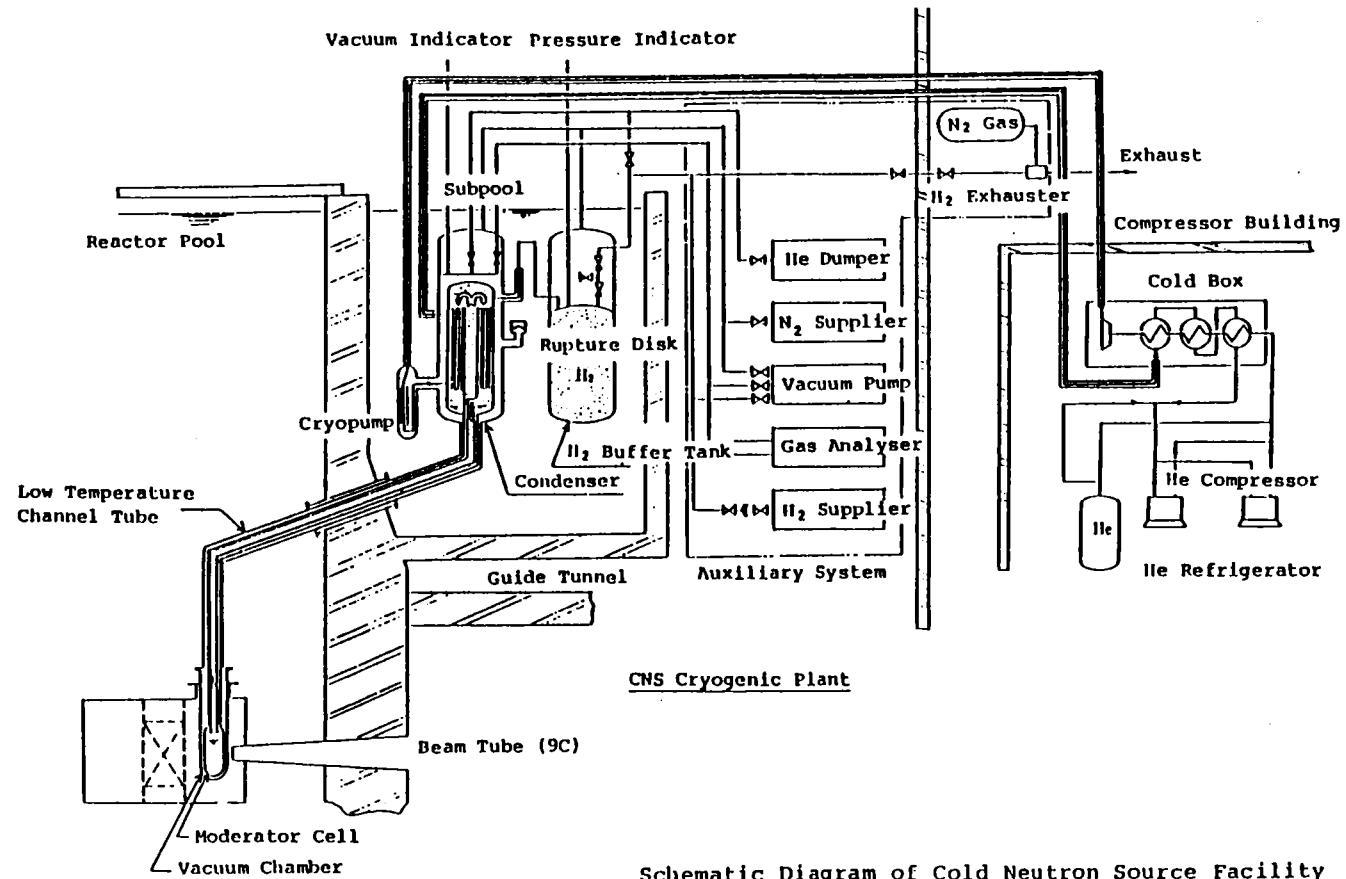

CNS Cryogenic Plant

Schematic Diagram of Cold Neutron Source Facility

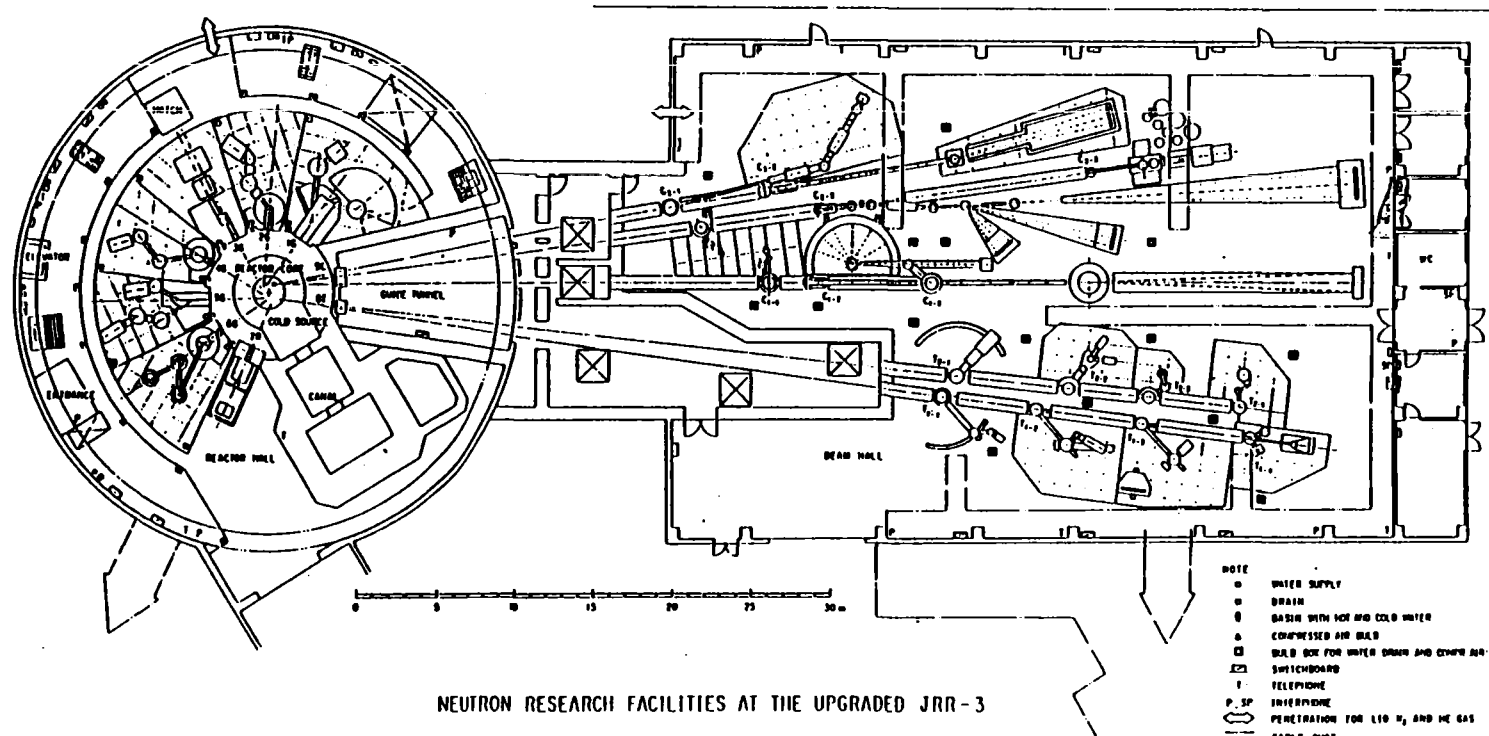

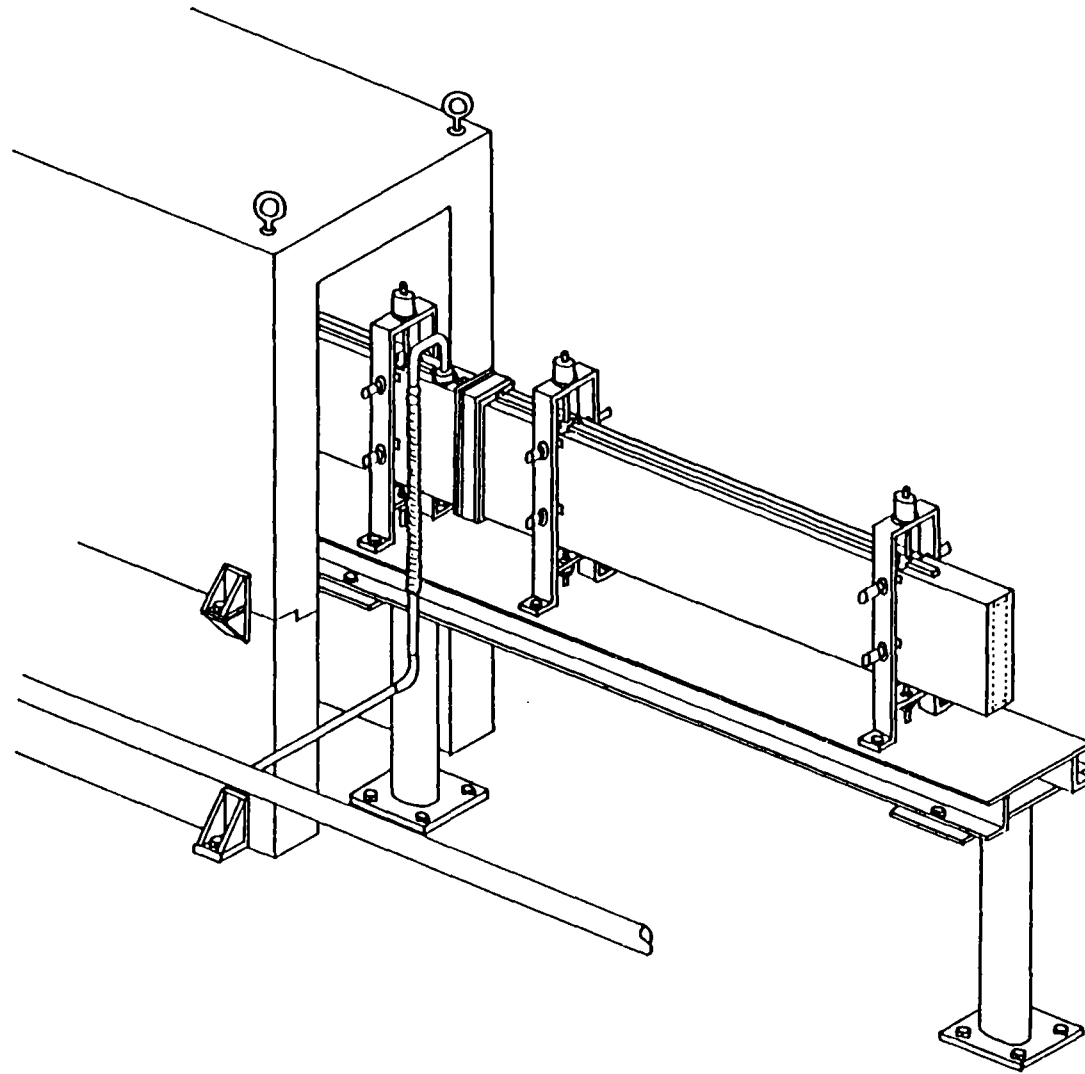

I s o m e t r i c V i e w o f N e u t r o n G u i d e T u b e

J R R - 3 Neutron Guide Tubes

	CHARACTERISTIC WAVELENGTH (A)	BEAM CROSS-SECTION (cm)	CURVATURE (m)	LENGTH (m)	NEUTRON FLUX *) (cm ⁻² s ⁻¹)
T1	2	2 X 20	3337	60	2. 1x10 ⁸
T2	2	2 X 20	3337	59	2. 1x10 ⁸
C1	4	2 X 12	834	31	3. 1x10 ⁸
C2	4	2 X 12	834	51	2. 8x10 ⁸
C3	6	2 X 12	371	31	2. 3x10 ⁸

*) : calculated results for perfect guides

total length = 232 m

NEUTRON MIRROR : NATURAL NICKEL COATED BOROSILICATE GLASS

GUIDE TUBE UNIT : 85cm length

FABRICATION ERROR OF UNIT : 0.005 mm (average)

INSTALLATION ERROR (average)

IMPERFECTION SPACIAL ALIGNMENT : 0.008 mm

IMPERFECTION ANGULAR ALIGNMENT : 5.3x10⁻⁶ rad

