

FEASABILITY OF THE GAMMA CAMERA ACCEPTANCE TESTING PROCEDURE INTRODUCED BY THE SWISS FEDERAL OFFICE OF PUBLIC HEALTH

S. BAECHLER¹, F. CORMINBOEUF², R. LINDER³, PH TRUEB³, J. MALTERRE⁴, A. BISCHOF DELALOYE⁴, F. BOCHUD¹, F.R. VERDUN¹

¹ University Institute for Radiation Physics, Lausanne, Switzerland

² Klinik + Poliklinik für Nuklearmedizin der Universität, Inselspital, Bern, Switzerland

³ Swiss Federal Office of Public Health, Bern, Switzerland

⁴ Nuclear Medicine Dept., University Hospital of Lausanne (CHUV), Lausanne, Switzerland

Abstract

Like in the field of radiology, digital systems are also becoming the standard in the field of nuclear medicine. This offers not only the possibility to process, transmit and archive data from patients more easily but also to introduce quantitative measurements for quality controls. In this framework, standards concerning the qualification of gamma camera systems have been updated and appeared to be useful to set legal requirements, in spite of the fact, that this is not their goals. The aim of this study was first to choose a set of tests described in standards to define measurements to be performed at the acceptance of the systems and after the regular maintenances (at least once every six months). Reference values are then established to control the stability of the system. To verify the feasibility, from a technical and a time requirements points of view, the tests proposed for the quality assurance programme have been applied on three gamma camera systems. The results of this study show that new requirements concerning the quality assurance of gamma camera of the Swiss Federal Office of Public Health based on international standards required to slightly modify some procedures to reduce the time necessary for the acceptance and status tests.

Introduction

The Swiss ordinance related to the use of unsealed radioactive sources requires the supplier to carry out an acceptance test on all imaging devices exploited in the field of nuclear medicine before they can be used on patients [1]. Moreover, a maintenance procedure of the imaging device has to be performed at least every six months by properly trained staff. This maintenance has to be followed by a status test that assures the integrity of the system before it can be used for further clinical applications. Daily and weekly stability tests, in charge of the users of the system, are also defined. According to the Swiss ordinance, all the measurements required for the acceptance and the status tests should follow International standards of either the NEMA (National Electrical Manufacturers Association) or IEC (International Electrotechnical Commission) [2-3]. In practice, it appeared that the standards available at that time were not sufficiently precise to allow the technical staff from the manufacturers to perform these tests. Thus, acceptance and status tests performed were manufacturer dependant and could not allow comparing the performance of different systems. Following the progress of technology, two standards have been recently published within the framework of the qualification of gamma cameras (NEMA - NU-1, 2001 and IEC 61675-2, 1998). In this context, the Swiss Federal Office of Public Health has proposed a set of tests based on these international standards for acceptance and status tests. This work presents these recommendations, shows their feasibility, evaluates the time and material required and proposes slight modifications to simplify a few measurements. The scope of this study was not to compare the performance of different gamma camera systems.

Materials and Methods

The background document of this work is the standard NEMA NU-1. Table 1 summarises the tests required in the framework of acceptance and status test (AT: acceptance test and ST: status test (six-month frequency)).

Table 1. Parameters and minimal frequency required for gamma camera systems in Switzerland.

Ref	Parameters to verify	Periodicity	Remarks
Z1	Intrinsic flood field uniformity	AT + ST	NEMA 2.3
Z2	Homogeneity of the system	AT	control of all the collimators
		AT + ST	visual monitoring
Z3	Intrinsic energy resolution	AT + ST	NEMA 2.2
Z4	Intrinsic resolution	AT or if Z5 is out of the tolerance	NEMA 2.1
Z5	System spatial resolution	AT	NEMA 2.4 with collimator
		AT + ST	phantom with bars, visual comparison with reference
Z6	System planar sensitivity	AT + ST	NEMA 3.8 AT with all the collimators, SC only with the more used
Z7	System count rate performance with scatter	AT	NEMA 3.4
Z8	Pixel size	AT + ST	
Z9	Spatial linearity	AT	NEMA 3.1
	System linearity	AT + ST	visual comparison
Z10	System documentation	AT + ST	specific to the manufacturer
Z11	Wholebody system spatial resolution	AT	NEMA 2.7
		AT + ST	phantom with bars
Z12	correction values for the centre of rotation	AT + ST	specific to the manufacturer
Z13	Quality of the slice image	AT + ST	according to data of the manufacturer, Jaszczak phantom
Z14	Transmission sources	AT + at the change of source	according to data of the manufacturer

Three installations have been tested in this study: a single head system (Millennium - General Electric - USA), a two head system (E.Cam - Siemens - Germany) and a three head system (Triad - Trionix – USA). The parameters to be assessed are the following:

Intrinsic homogeneity

This measurement is done with a point source without collimator. The distance between the source and the head must be higher than 5 times the useful field of view (UFOV) of the camera. The source is placed in a lead box with a copper filtration of at least 2 mm. The counting rate should not exceed 20 kcps. The pixels must contain at least 10'000 events and

the pixel size must be $6.4 \text{ mm} \pm 30\%$. The pixels at the edge of the image and those for which the number of counts is lower than 75% of the average value are set to zero. A low-pass filter is then applied. The evaluation of the homogeneity is done with the UFOV and the central FOV (CFOV = 75% of UFOV).

The integral uniformity consists in looking for the minimal and maximum pixel values among the whole UFOV or CFOV. The following relationship is applied: $\text{Uniformity} = (\text{Max} - \text{Min})/(\text{Max} + \text{Min})$. The differential uniformity is calculated with the same formula, but with the maximum and minimum values on a reduced zone of 5 consecutive pixels of the image.

Intrinsic spatial resolution and geometrical linearity

This measurement requires a 3 mm thick lead plate with 1 mm slits spaced by 30 mm, covering the whole surface of the camera. The line spread functions (LSF) are obtained by averaging the profiles of activity over a length shorter than 30 mm. The full width at half maximum (FWHM) and the full width at tenth of maximum (FWTM) are then measured. The pixel size must be lower than ten percent of the FWHM.

Spatial resolution and system sensitivity

Two capillaries ($\varnothing < 1 \text{ mm}$) are filled with Tc-99m and placed on a Styro foam at 10 cm of the collimator. One capillary is used to calculate the FWHM and FWTM. The second capillary is used to evaluate the pixel size. For the sensitivity measurement, a known activity is placed in a box at 10 cm of the collimator and the counting rate is noted.

(Intrinsic) energy resolution

Two point sources are placed successively and then at the same time in front of the head of the camera. The counting rate must not exceed 20 kcps. The spectrum is recorded so that the channel which contains the photoelectric peak records 10' 000 events. The calibration of the channels can be made because the 2 isotopes, Co-57 and Tc-99m, differ from 18.4 keV. The energy resolution is the ratio between the FWHM of the photoelectric peak of Tc-99m and its energy (140.5 keV).

Behaviour of the counting rate according to the activity with scattered radiation

A PMMA cylinder (Figure 1) is used for these measurements. According to the NEMA standard, a significant activity (about 10 GBq) of Tc-99m is introduced into the phantom and let decrease. One records the activity when the count rate decrease by 20% of the expected value. This procedure has been replaced by adding activity in the phantom (keeping the volume as much as possible constant) to reduce measurement time [4].

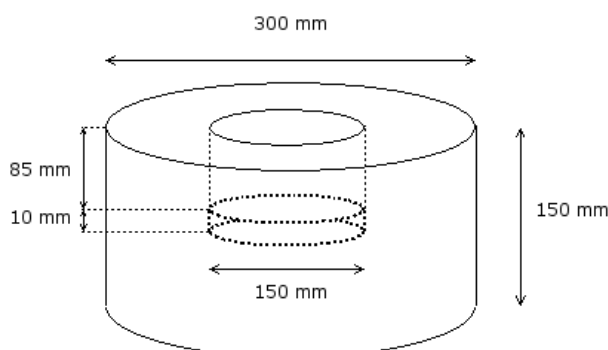

Figure 1. Test object used for the counting rate as a function of activity with scattered radiation.

Table 2. Summary of the conditions of acquisition.

Parameters	Source	Distance	Matrix	Zoom	Window	Test object
Intrinsic homogeneity	Tc-99m 20 MBq	>5 UFOV	64x64	1	15%	No
Intrinsic spatial resolution and geometrical linearity	Tc-99m 200 MBq	>5 UFOV	512x512	>2	15%	Slit
System spatial resolution (ST)	Co-57	In contact	512x512	1	15-20%	Slit phantom
System sensitivity	Tc-99m 200 MBq	At 10 cm	64x64	1	15%	No
System spatial resolution (RT)	Tc-99m 50 MBq	At 10 cm	512x512	>2	15%	2 capillaries ø 1mm
Intrinsic energy resolution	Tc 20 MBq Co 20 MBq	>5 UFOV	64x64	1	15%	No
Counting rate behaviour	Tc-99m 8 GBq	In contact	64x64	1	15%	Fig. 1

Results and discussion

Intrinsic homogeneity

The units have, in general, the necessary software in a service mode. The results obtained for the three installations are presented in Table 3. This measurement is fairly easy and quick.

Table 3. Results of the evaluation of the intrinsic systems homogeneity.

Camera (head)	Integral uniformity (%)		Differential uniformity (%)	
	UFOV	CFOV	UFOV	CFOV
E.Cam (1)	3.00	2.37	1.59	1.55
E.Cam (2)	3.14	2.65	1.98	1.92
Millennium	7.15	5.75	3.66	3.06
Triad (1)	2.11	2.03	1.43	1.22
Triad (2)	4.25	3.15	1.62	1.62
Triad (3)	3.71	2.66	1.88	1.88

Intrinsic space resolution and geometrical linearity

For the geometrical linearity, the LSF are fitted and the standard deviation is compared to a line. An example is given in Figure 2. The results are summarized in Table 4. The main problem associated to this measurement is that the test object required is not commercially available. Its positioning can also be difficult.

Table 4. Intrinsic resolution and linearity.

Camera	FWHM (mm)	FWTM (mm)	Absolute linearity (mm)
E.Cam	3.9	7.4	0.5
Millennium	4.2	8.3	0.6
Triad	4.2	8.0	0.7

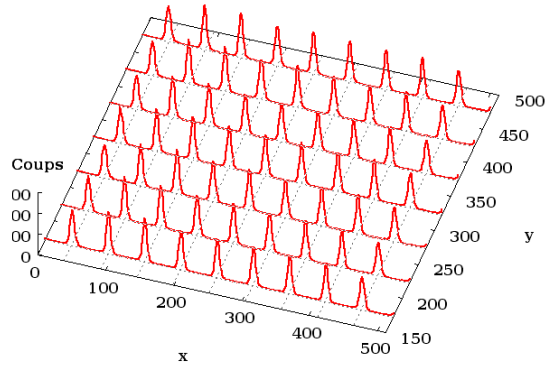

Figure 2. Example of a series of profiles obtained on an image used for the evaluation of geometrical linearity.

Spatial resolution and system sensitivity

The results are presented in Table 5 with the sensitivity factors of the system. These measurements are rather straightforward to perform and do not require expensive material.

Table 5. Results of the evaluation of the spatial resolution and sensitivity.

Camera, heads, collimator	FWHM (mm)	Sensitivity (coups.s ⁻¹ .MBq ⁻¹)
E.Cam, 2, LEHR	7.6	33.0
Millennium, LEGP	10.2	55.3
Millennium, LEHR	8.1	30.9
Triad, 1, LEGP	9.8	54.7
Triad, 1, LEUR	7.4	28.2

(Intrinsic) energy resolution

This measurement requires some functionalities of the system such as the possibility to accumulate spectra during a few minutes. This was not, for example, possible for the Triad system. Figure 3 shows a spectrum obtained for one particular system.

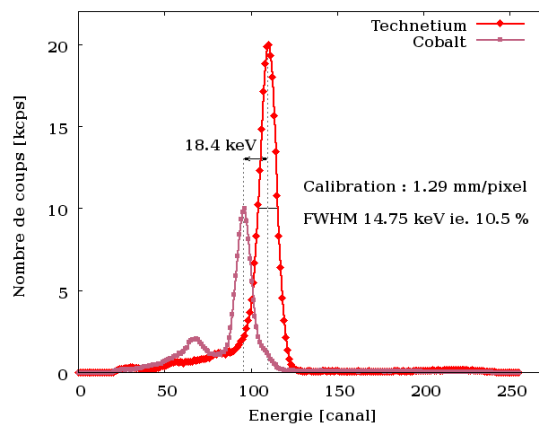

Figure 3. Example of intrinsic energy resolution.

Counting rate as a function of activity

The procedure used does not strictly respect the NEMA standard since the activity was varied. From a graph such as the one presented in Figure 4, the maximum counting rate of the installation and the counting rate for which the saturation of the system results in a loss of sensitivity of 20% can be determined. These values permit also to determine the dead time of the installation [5]. Table 6 summarizes the results of this measurement.

Table 6. Counting rate and dead time.

Camera	Maximal counting rate (kcps)	Counting rate losses $\geq 20\%$ (kcps)	Dead time τ (μs)
E.Cam	84.3	44.8	4.4
Millennium	110	> 110	< 3.3
Triad	48.1	35.4	7.6

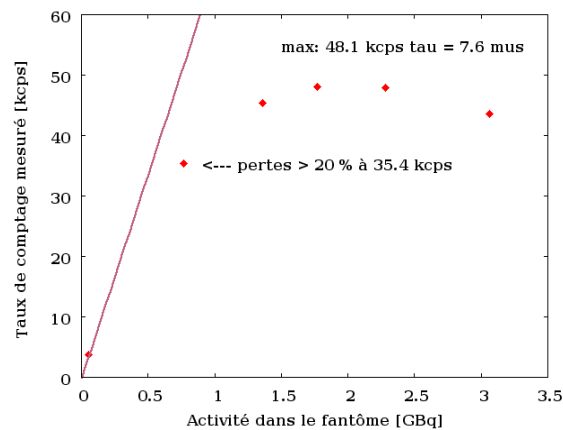

Figure 4. Counting rate [kcps] for the Triad camera plotted with regard to the activity in the phantom.

Conclusions

The project of a new directive about quality controls of gamma cameras will permit a uniform qualification of the systems. A set of minimal acceptance tests is now available and requires two and a half hour acquisition time per head. For status test the acquisition time can be reduced to one hour and a half per head, taking into account that the longer test (intrinsic homogeneity) is often required in the process of the maintenance. The main problem encountered during this study is the manipulation of very high activities when dealing with the assessment of the counting rate behaviour. To reduce exposure, manufacturer staff should be properly trained and the strict respect of the standard (let the source decrease) should be preferred since this test is only required for acceptance of the unit where time constraint is less a problem. Concerning stability tests, one should control at least weekly homogeneity and daily the picking and contamination of the system.

References

- [1] Swiss Ordinance on the Use of Unsealed Radiation Sources, edited by the Federal Chancellery, Berne (1997)
- [2] NEMA Standards Publication NU 1-2001, Performance Measurements of Scintillation Cameras }, National Electrical Manufacturers Association, Rosslyn, USA, 2001
- [3] International Electrotechnical Commission. EC Standard 61675-2: Radionuclide Imaging Devices—Characteristics and Test Conditions. Part 1. Single photon emission computed tomograph. Geneva, Switzerland: International Electrotechnical Commission; 1998.
- [4] Quality Control of Gamma Camera System. IPEM report 86, 2003. Fairmount House, 230 Tadcaster Road York YO24 1ES UK.
- [5] CHERRY Simon R., PHELPS Michael E., SORENSON James. Physics in Nuclear Medicine. 3^{ème} édition Saunders, 2003 Philadelphie.