

The resonance integral
of thorium metal rods.

E. Hellstrand and J. Weitman

AE-48



AKTIEBOLAGET ATOMENERGI

STOCKHOLM • SWEDEN • 1960

THE RESONANCE INTEGRAL OF THORIUM METAL RODS

Eric Hellstrand and Jakob Weitman

Summary:

The resonance integral for thorium metal rods of different diameters has been determined by the activation method. The irradiations took place in the central channel of the reactor R1, where the energy dependence of the neutron flux had earlier been investigated with a fast chopper up to about 1 keV.

The absolute calibration was made with gold as a standard. The true resonance integral for gold was taken from the literature as 1500 ± 35 b. The experimental values for thorium were fitted to two alternative expressions with the following results:

$$RI = \left(1.70 + 15.9 \sqrt{S/M} \right) \pm 5.5 \%$$

$$RI = 17.3 \sqrt{S/M + 0.06} \pm 5.5 \%$$

The measurements were made for S/M values in the range 0.14 - 0.87 cm²/g. The main contribution to the margin of errors arises from the uncertainties in the cross sections used and in the correction for the departure of the neutron energy distribution from the 1/E form.

Manuscript completed September 1960

Printed March 1961

To be published in Nucl. Sci. Eng.

List of contents

<u>Introduction</u>	page
Theoretical calculations	3
Choice of RI formula	3
Earlier measurements	4
Method of measurement	5
<u>Experimental procedure</u>	5
Irradiation	5
Activity measurement	9
<u>Special effects</u>	11
Fission product background	11
Shielding	11
Flux gradients	12
Choice of cadmium cutoff	12
<u>Neutron spectrum</u>	13
Spectrum below 1 keV	13
Spectrum above about 1 keV	15
Sensitivity of RI to the form of the spectrum	16
<u>Results</u>	19
Absolute calibration	19
Relative calibration	20
Limits of errors	23
<u>Discussion</u>	25
Comparison of experimental values	25
Comparison with calculated values	28
<u>References</u>	31

THE RESONANCE INTEGRAL OF THORIUM METAL RODS.

E. Hellstrand, J. Weitman

Introduction.

Theoretical calculations.

Methods for numerical calculations of resonance integrals in lumps have been developed by several authors. Accounts of recent work have been given by Dresner (1), Adler, Hinman and Nordheim (2), Nordheim (3), Chernick and Vernon (4) and Vernon (5). The good agreement between calculated and experimental values for uranium metal and oxide is confirmation for the assumptions made in the theoretical approach. In the case of thorium, however, the accuracy of the numerical calculations has formerly been limited by the less detailed knowledge of the parameters of thorium resonances. Partly on account of this, partly because of less well established experimental values for the resonance integral of thorium, the agreement between calculations and experiments has been poorer in this case. New measurements on thorium resonances with high resolution have been reported by the Columbia group (6). These measurements cover an energy range up to about 2 keV, and furnish material for more accurate calculations in both the resolved and the unresolved energy region.

Choice of RI formula.

The geometric dependence of the resonance integral is usually expressed with the relation first proposed by Gurevich and Pomeranchouk (7).

$$RI = A + B \sqrt{S/M} \dots\dots\dots (1)$$

RI is the resonance integral, A and B constants and S/M is the surface to mass ratio of the lumps in question.

This formula is a good approximation, especially in cases where broad resonances give the largest contribution to the total resonance integral (for the distinction between broad and narrow reso-

nances, compare for instance (2)). For uranium this is true for most dimensions of practical interest. For thorium, on the other hand, the broad resonances are not so predominant and Eq. (1) may therefore be a less good approximation. Vernon (5) suggests that an expression of the form obtained in the narrow resonance approximation

$$RI = a \sqrt{S/M + b} \dots\dots\dots (2)$$

could be substituted for Eq.(1) in the case of thorium. However, with suitable values of the parameters in Eq.(1)and(2) the two expressions will fit the experimental results equally well within a large range of S/M. Only for very small S/M values will the graph of Eq(2)deviate distinctly from that of Eq.(1). The results of both theoretical calculations (3) and experiments (8), (9) * indirectly give support to Eq.(2) in this region.

Earlier measurements.

Several measurements of the effective resonance integral for thorium have been reported in the literature (8) - (13). The measured resonance integrals have been fitted to different semi-empirical formulas with the surface to mass ratio, S/M, as independent variable. In most measurements (8) - (11) an expression of the form given in Eq(1) has been used.

Except for Sher's result (11) which was based on a measurement of the resonance escape probability, p, in a Th-U²³⁵ lattice, all earlier measurements were made by reactivity methods. The reactivity effect of different thorium samples was measured either with danger coefficient, reactor period or pile oscillator technique. In all cases the samples were surrounded by cadmium, allowing the epithermal effect to be studied apart from the thermal one.

A comparison between the reported expressions for RI reveals a considerable disagreement. We have therefore considered it worth while to perform a new series of measurements on thorium. As reactivity measurements may easily be subject to systematic errors we chose a different method - the activation method - for our measurements.

* The result given in (9) is only preliminary.

Method of measurement.

The measurement of the resonance integral as a function of S/M was divided into two parts. Firstly, a series of rods with different diameters were irradiated under cadmium and the activities from representative samples were measured. This gave after normalization to unit neutron flux the relative variation with S/M of the neutron absorption above the cadmium cutoff.

Secondly, an absolute calibration in barns was performed for two rod dimensions by a comparison with gold, assuming the infinitely dilute resonance integral for gold as known. The necessary counter calibrations for relating the thorium and gold activities were obtained by irradiating a thorium sample and a pair of gold foils in the same thermal flux. From the observed activities of these samples and the known thermal cross sections for thorium and gold the desired constants were determined.

Experimental procedure.

Irradiation.

The cadmium covered cylindrical thorium rods were irradiated in the central channel of the heavy water reactor R1. The position of the rods in relation to the reactor lattice is shown in Fig. 1. The 150-mm wide channel is air filled. The length of the rods was 150 mm and their central part consisted of a 1-mm thick disc (compare Fig. 2) which served as a measuring sample, the S/M -value being proportional to $\frac{1}{r}$.

The same arrangement was also used for the gold foil irradiations. On these occasions the foils, made from 0.1-mm thick sheets of a lead-gold alloy containing 0.1 weight percent of gold, were placed at the same height as the measuring samples in the thorium irradiations. Irradiations were made with the Pb-Au foils placed both horizontally and vertically. No significant difference was observed between the activities from these foils.

The neutron flux was monitored with two 0.2-mm-thick gold foils placed on top of the rods, as shown in Fig. 2.

The arrangement of the thermal column irradiation is shown in Fig. 3. The two lead-gold foils were placed on either side of a 1-mm thick thorium disc, forming a small package which

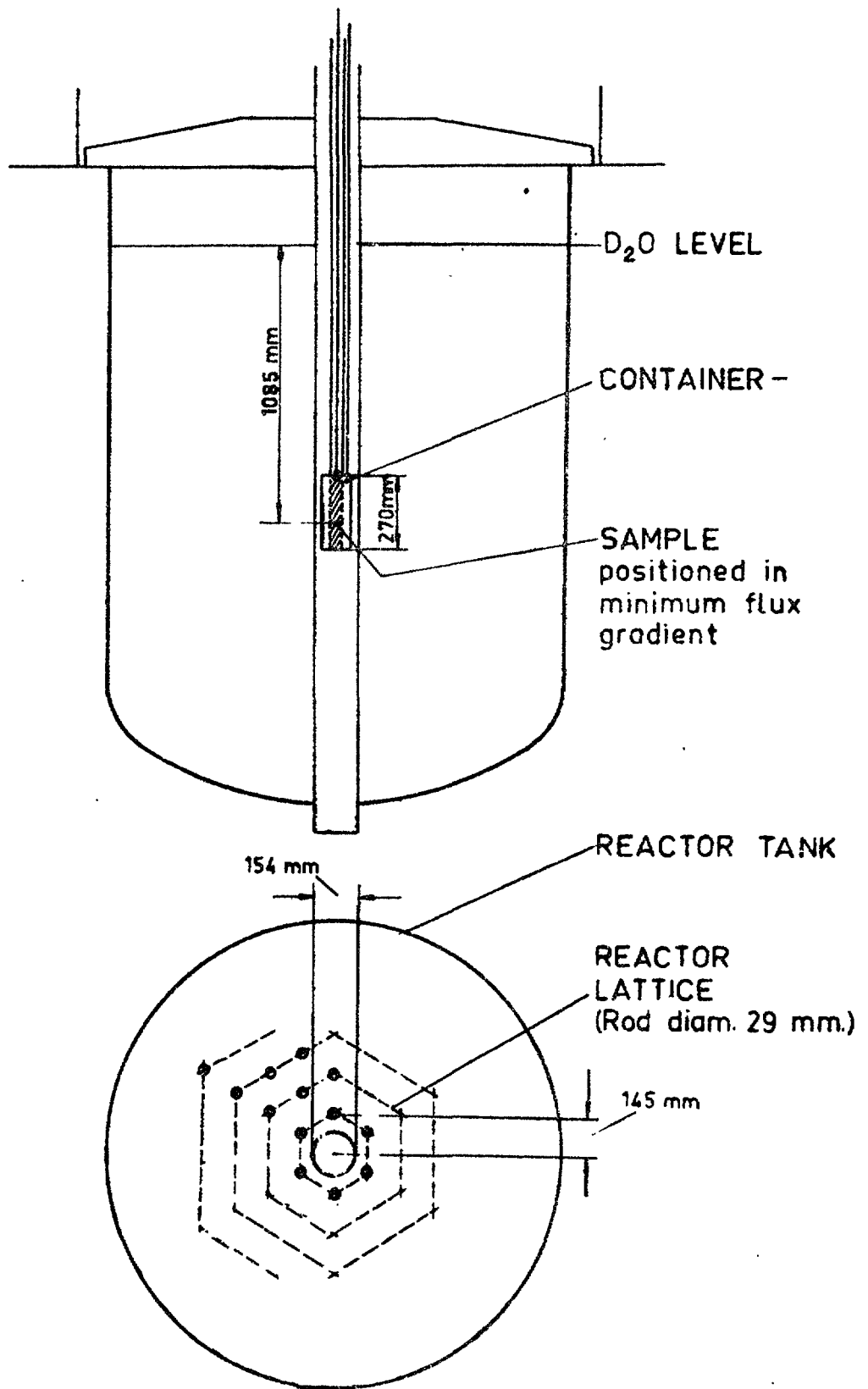

Fig. 1. Experimental assembly in the central channel of the R1 reactor.

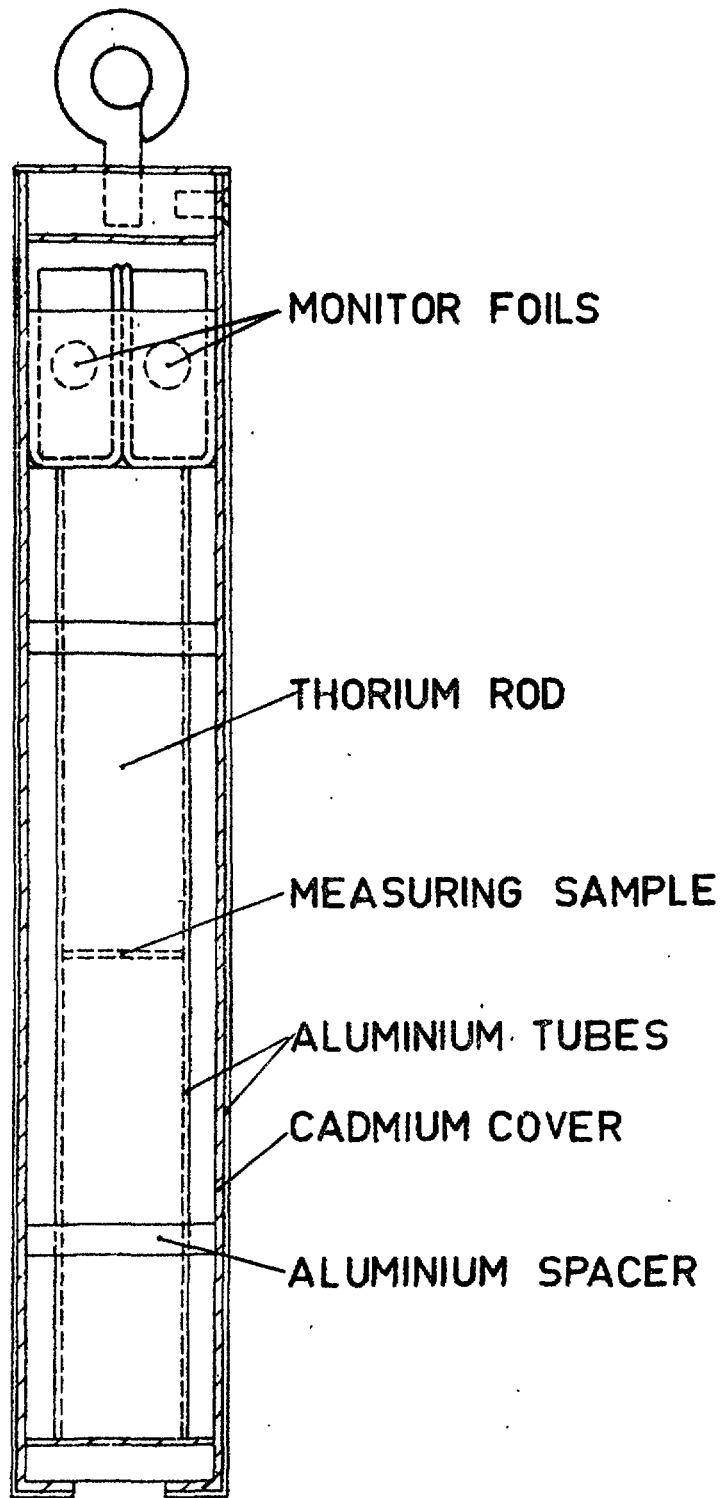

Fig. 2. Position of the thorium rods with the measuring sample and the monitor foils inside the cadmium tube.

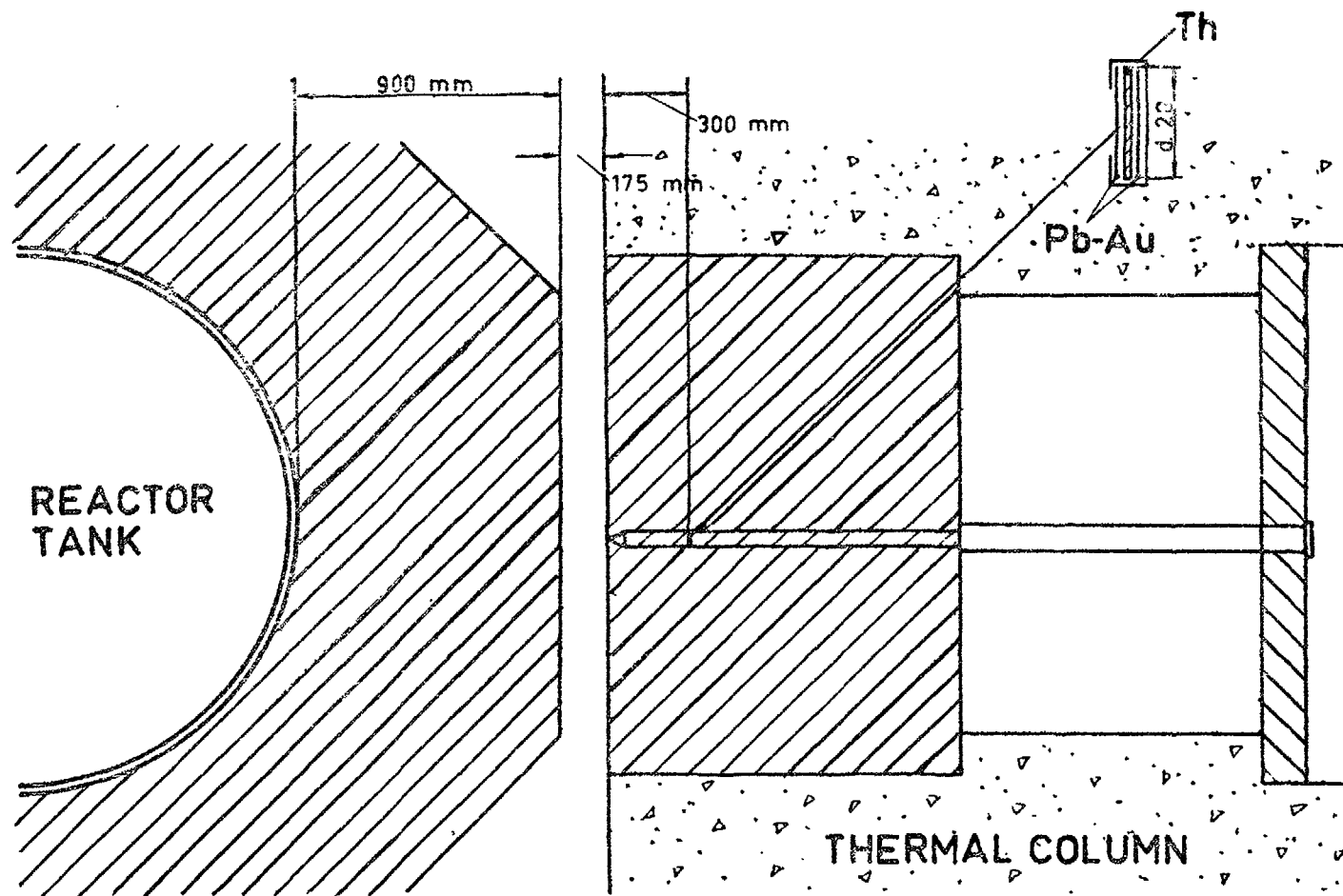

Fig. 3. Position of the thorium and lead-gold samples in the thermal column runs.

was wrapped in aluminium foil. Between the package and the reflector were 30 cm of graphite. The cadmium ratio for the lead-gold foils at that position was about 1700.

Activity measurement.

The reactor power and the time of irradiation were in each case chosen to give the most suitable conditions for the subsequent activity measurements, that is good statistics in short times and only small differences in counting rates for samples with different diameters.

The (n, γ) reaction in Th^{232} gives rise to the following decay chain

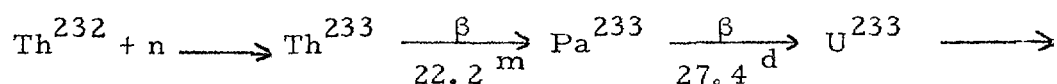

Thus, the Th^{233} and the Pa^{233} activities are both proportional to the neutron capture in the thorium rods. We used the Pa^{233} activity for our measurements. It has several γ -lines suitable for measurements with a γ scintillation spectrometer. A strong line at 105 keV and a group of lines at about 330 keV were chosen in our case. The peak to background conditions and the energy ranges used are illustrated in Fig. 4.

The thorium discs were not dissolved before their activity was measured. To assure a constant counter efficiency of the scintillator irrespective of the radius of the samples, the discs were placed at a distance of 40 cm from the crystal. The thicknesses of the discs showed only small variations. As the photo absorption in the 1-mm thick discs is large, especially for the low energy γ peak, the obtained activities were normalized to the surfaces of the discs rather than to their masses.

The activities from the lead-gold foils and the gold monitors were measured with β scintillation counters.

Four independent calibrations in barns were made. Three of them were made on 20-mm diameter rods and one on a 25-mm diameter rod.

INTENSITY

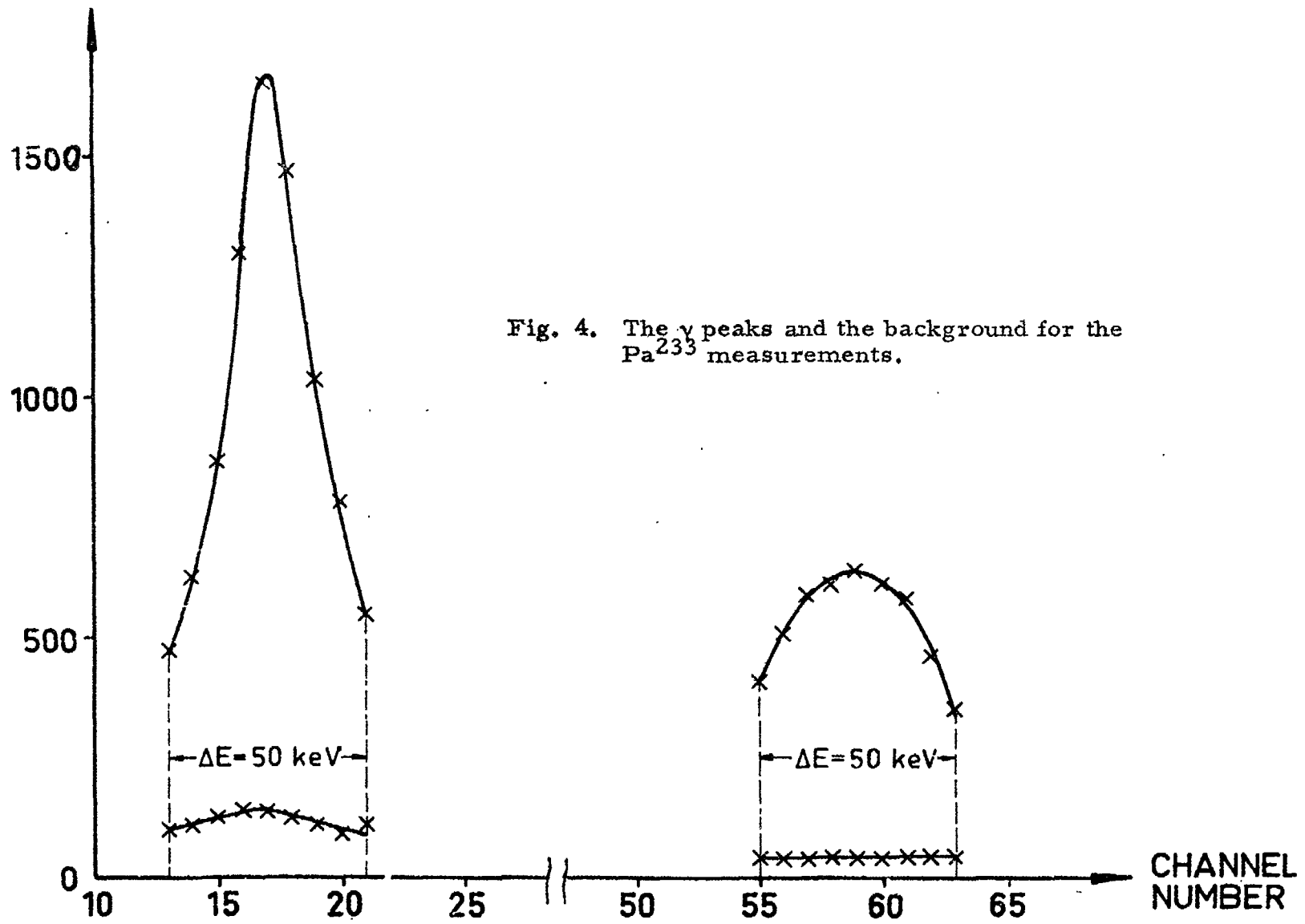

The relative variation of the resonance integral was studied on rods with six different diameters ranging from 4 to 25 mm. With a density of 11.5 g/cm^2 , as measured for our samples, this corresponds to a S/M range of $0.87 - 0.14 \text{ cm}^2/\text{g}$.

Special effects.

Fission product background.

By postponing the measurements till about 30 days after the irradiations any interference from activities caused by fast fission in thorium could be considered negligible.

In order to check this assumption thorium samples were irradiated both in the central channel and in the thermal column. The activity from the samples was measured both within 30-40 min after the irradiation and more than 30 days later. From the thermal column irradiation we obtained the ratio between the Th^{233} and Pa^{233} activities, $N^{\text{Th}}/N^{\text{Pa}}$. The central channel run gave in the first approximation $N^{\text{Th} + \text{Fp}}/N^{\text{Pa}}$, where the index Th + Fp denotes the sum of Th^{233} and fission product activities. From the difference in the two ratios an estimate of the ratio $N^{\text{Fp}}/N^{\text{Pa}}$ about 30 minutes after the irradiation could be made. From this estimate and an assumed decay of N^{Fp} with time as $t^{-1.2}$ it could be concluded that $N^{\text{Fp}}/N^{\text{Pa}}$ is negligibly small 30 days after the irradiation.

Shielding.

The position of the gold foils for monitoring the flux is illustrated in Fig. 2. Although thorium has no low resonances which may cause pronounced shielding of the lowest gold resonance, some scattering and shielding may occur, especially for the largest thorium rods. A special investigation was therefore made. Cadmium covered foils were irradiated at the normal position and at a reference point 40 cm above the monitor foils. Irradiations were made with and without the thickest thorium rod. Normalized to the same reference foil activity, the two monitor activities agreed within 1 %.

As has been mentioned earlier, the lead-gold foils had a thickness of 0.1 mm and contained 0.1 % of gold. The self shielding of the 4.9 eV resonance in the foils was calculated to

be 1.5 % from the expression given by Wilkins (14).

As cadmium has many resonances the cadmium cover around the rods may shield some of the thorium resonances. A perusal of the list of resonances for thorium and cadmium reveals that two broad cadmium resonances at 120.2 and 193.2 eV correspond very closely to the thorium resonances at 121.0 and 193.0 eV. The latter belong to the group of about 12 narrow resonances in thorium (15) which contribute in a typical case (diam. 10 mm) about 1 barn to the total surface integral (3). If it is assumed that all resolved narrow resonances contribute an equal amount to the resonance integral a complete shielding of the 121 and 193 eV resonances would mean a decrease of about 1.5 % in RI. The shielding is considerably less than complete and therefore no correction has been applied.

Flux gradients.

The gradient of the flux at the position of irradiation in the central channel was small. Errors caused by minor uncertainties in the position of the samples were therefore negligible. In the thermal column runs the effect of gradients was eliminated by positioning a lead gold foil on either side of the 1-mm cutoff thick thorium disc (compare Fig. 3). The difference in activity between the gold foils was only about 1 %.

Choice of cadmium cutoff.

The thermal cross section for thorium is 7.45 b. The epicadmium $1/v$ contribution will therefore be considerable. The choice of Cd cutoff was based on the calculations by Stoughton et al. (16). In their work a value of 0.55 eV is given for a cadmium cylinder with a height-to-diameter ratio of 2:1 and a thickness of 1.02 mm. Our cadmium was somewhat thicker and the height-to-diameter ratio was larger. We have therefore chosen a cadmium cutoff of 0.60 ± 0.05 eV.

Neutron spectrum.

The definition of a resonance integral implies the existence of a neutron energy distribution which varies as $1/E$. Any measurement of resonance integrals should therefore be made in such a neutron spectrum. The great difficulty is, however, that there is no direct way of checking the spectrum over the whole energy range of interest. Generally, one may obtain some information about the flux by using different types of resonance detectors (Au, Co, Mn, Mo, etc.). Such measurements are, however, quite approximate, and the high-energy limit is about 500 eV.

Spectrum below 1 keV.

In our case the neutron flux had earlier been subject to a special investigation with a fast chopper (17). The neutron beam scattered out of the channel by different scatterers was analyzed with the chopper. An iron collimating system assured that the neutrons in the beam originated from the centre of the channel. Fig. 5 illustrates the variation of the product $E \phi(E)$ with time of flight (the latter being proportional to $1/\sqrt{E}$) for a lead scatterer, a graphite scatterer and a D_2O scatterer (of about 20-cm height). The energy range shown on the figure extends from about 2 eV to about 1 keV. The curves are normalized at 5 eV.

For a $1/E$ flux the curves in Fig. 5 should be horizontal. All three deviate, however, distinctly from horizontal lines. The D_2O curve slopes downwards as the energy increases. For the lead and graphite scatterers, on the other hand, there is a gradual increase in height from a value of 1 at 5 eV to 1.04 - 1.06 at about 1 keV. For energies below 5 eV the height of the two latter curves may be considered constant. The bump that appears in the joining region between the $1/E$ flux and the Maxwellian part of the flux (not shown on the figure, compare (17), Fig. 14), is of negligible importance above the cadmium cutoff energy, 0.6 eV.

One might assume that the lead curve fairly well represents the actual neutron spectrum at the centre of the airfilled channel. For our irradiations, however, the cadmium around the samples somewhat suppressed the nearest fission sources. This effect should make the deviation from a $1/E$ distribution less pronounced for the energy region

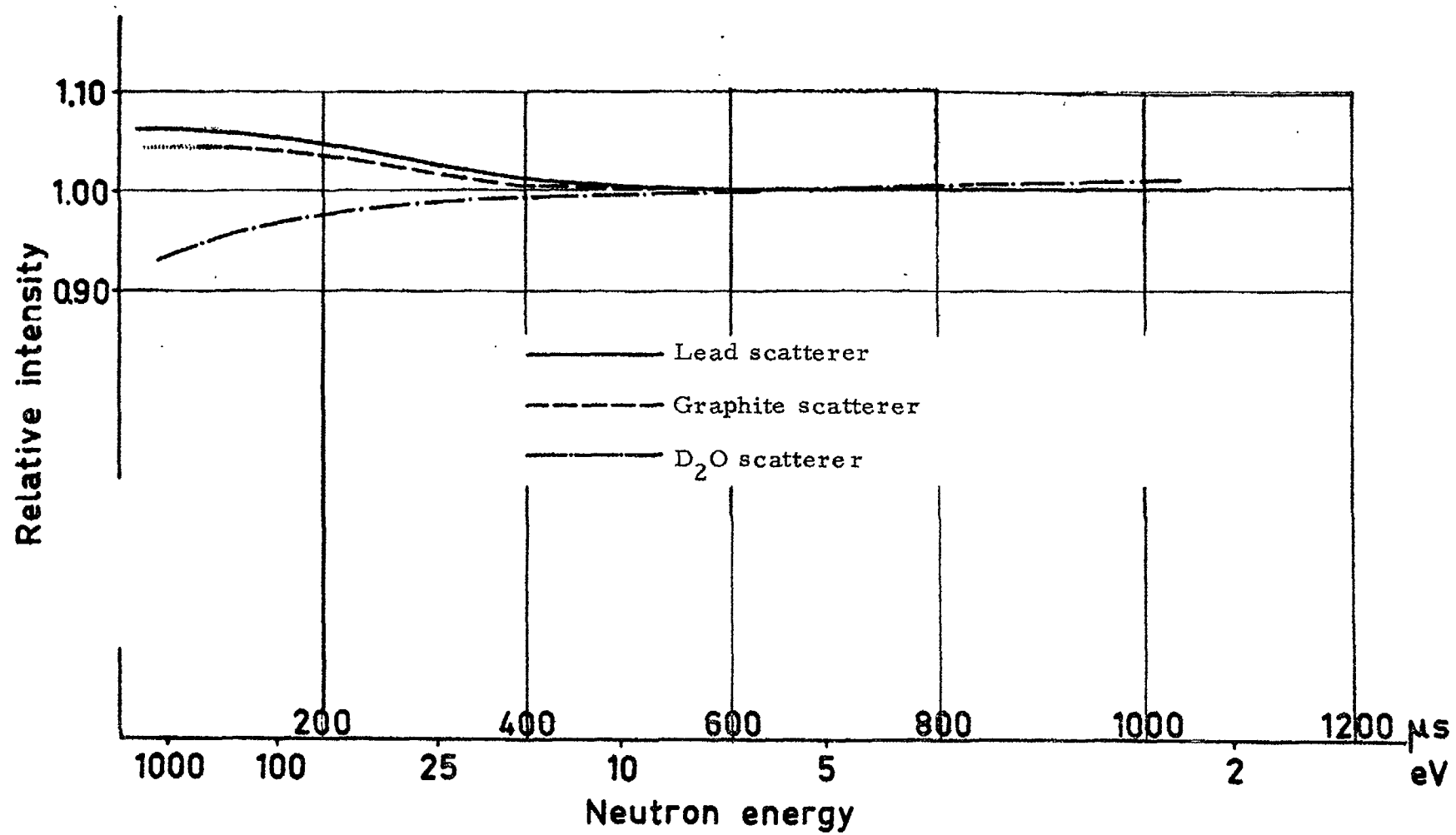

Fig. 5. The epithermal neutron spectrum from different scatterers.

discussed in this paragraph. As verified experimentally with a cadmium covered scatterer (compare (17) for details) the effect is small. For the following discussion we have therefore assumed that the graphite curve, which lies somewhat lower than the lead curve, is representative for the flux, in which our calibration took place.

The gold and thorium resonance absorption occur at different energies. For the thin gold samples the activity is almost exclusively due to the 4.9 eV resonance. The activity in the thorium rods, on the other hand, arises from a number of resonances covering a large energy range. As our neutron spectrum deviates somewhat from $1/E$, a correction factor must therefore be applied when relating the thorium and gold activities in the absolute calibration. The determination of such a correction factor requires knowledge of the spectrum up to very high energies. The experimental curves, however, give no information above about 1 keV, but we assume here a horizontal continuation of the graphite curve up to fission energies (compare below). In that case, the value of the correction factor, γ , is given as the ratio of the product $E \phi(E)$ at the mean energy of resonance absorption in thorium to that at 4.9 eV. It is true that the resonance absorption, energywise, is differently distributed for different rod sizes, but considering the uncertainty of the spectrum curve, $\pm 3\%$, and its small slope, the same mean energy of a few hundred eV is assumed for all rod sizes. From the curve we thus obtain for γ the value $1.04 \pm 3\%$. This factor should be applied only to the resonance part in thorium and not to the $1/v$ part. The main contribution to the latter occurs below 5 eV, in which region the $E \phi(E)$ curve is almost horizontal.

Spectrum above about 1 keV.

As mentioned above, no experimental information about the spectrum is available above approximately 1 keV. Accurate calculations of the spectrum are in addition difficult to perform as the central channel is airfilled. However, the amount of heavy water between the samples and the nearest fuel rods is about the same as for a point half-way between two fuel elements in a full lattice. The spectrum at such a point should therefore fairly well correspond to

the spectrum at the position for irradiation. A calculation of the spectrum between two fuel rods has been performed by K. Jirlow (unpublished) using age theory and considering the fuel rods as line sources. Disregarding the effect of resonance capture, the calculated spectrum is very nearly $1/E$ distributed up to about 100 keV, where it starts to fall off faster than $1/E$. With the cadmium cylinder used in our irradiations (height 200 mm, diameter 35 mm), the deviation from the $1/E$ form may be somewhat more pronounced, because of the suppression of the nearest fission sources by the large piece of cadmium. However, it has not been possible to make any reliable estimate of the magnitude of such a deviation ¹⁾ or of its effect on the measured resonance integrals (compare below). Now, the whole contribution to RI from energies above 30 keV only amounts to about 1 b. Thus, even if a large deviation from $1/E$ at high energies existed in our measurements, it should make our results only a few percents too low.

Sensitivity of RI to the form of the spectrum.

As an illustration to the dependence of RI on the form of the neutron spectrum the following measurement was made. Two 20-mm diameter rods were subsequently irradiated in the central channel. For the first irradiation the container around the rod (compare Fig. 1) was air filled, for the second it was filled with D_2O . The flux was in both cases monitored with gold foils, i. e., the normalization occurred at an energy of about 5 eV. The energy distribution of the neutrons for the second irradiation should be very close to the D_2O curve on Fig. 5. This curve lies at 500 eV about 10 to 11 % lower than the graphite curve.

An independent check of the relative flux levels at about 500 eV was made for the two runs using molybdenum and gold in the following way. Cadmium covered foils of lead-gold and molybdenum (0.1-mm thick) were irradiated back to back with and without D_2O in the container. The ratio of the Mo^{99} and Au^{198} activities for the two runs was determined. Without D_2O the ratio was 1.10 times the ratio with D_2O . As the main contribution to the Mo^{99} activity most probably comes from the 480 eV resonance in Mo^{98} (lack of detailed knowledge of $\sigma(E)$ for Mo^{98} makes this statement somewhat uncertain), the Mo^{99}/Au^{198} ratio is a relative measure of the flux at 480 eV and 5 eV. The 10 % difference found for the two ratios agrees well with the chopper data.

1) An experimental study of this cadmium effect is under way using threshold detectors (sulphur and indium). Results from this measurements will be given in a report concerning thorium oxide.

The difference in the relative flux levels for the two runs will be still more pronounced at higher energies. Quite different values should therefore be expected for the resonance integrals measured in the two spectra (the difference in $1/v$ absorption is negligible). The difference for the 20-mm diameter rods came out as 1.3 ± 0.3 b. An approximate estimate of how this difference is distributed over different energy groups can be made in the following way. According to the curves on Fig. 5, one may write as a first approximation

$$\phi_{D_2O} = (1 - \delta \ln E/5) \phi_{air} ; \quad 2 \text{ eV} < E < 1000 \text{ eV} \quad (3)$$

where ϕ_{D_2O} and ϕ_{air} are the neutron fluxes with D_2O and air, respectively, in the container, and δ is a constant. As seen from the formula the fluxes are normalized at 5 eV. The value of δ is obtained from the measured ratio of ϕ_{air}/ϕ_{D_2O} at 500 eV.

The total resonance absorption is divided into groups for which an approximate mean energy of absorption, E_m , has been assumed. With the aid of Nordheim's calculations (3) and Eq. (3) one then finds, with due consideration to the difference between Nordheim's result and ours, that about 0.3 b of the change in RI comes from the resolved energy region ($E < 400$ eV). To arrive at this value, 80 eV has been used for E_m . Moreover, if Eq. (3) is assumed to hold also for the interval 0.4 keV to 30 keV, with an approximate value for E_m of a few keV, 0.4 - 0.5 b of the difference would come from this energy region.

The remaining difference, 0.5 - 0.6 b, is a measure of the difference in absorption above about 30 keV. As such, it apparently constitutes a lower limit for the contribution to RI_{air} from energies above about 30 keV. The magnitude of that contribution is of importance when comparing experimental and theoretical values. As we do not know the true relation between ϕ_{air} and ϕ_{D_2O} for high energies and because of the great uncertainty ($\pm 75\%$) in the value quoted above, we cannot, however, use it for an accurate determination of the high energy contribution to RI_{air} in our experiments. - The results of the measurements with and without D_2O in the container are summarized in Table I.

Table I.

Relative epithermal absorption of 20-mm diameter rods in different neutron spectra.

Medium in container *	$\frac{E_1 \phi(E_1)}{E_2 \phi(E_2)}$; $E_1 = 500 \text{ eV}$ $E_2 = 5 \text{ eV}$		Epithermal absorption in 20-mm diam. thorium rods (relative units)
	From chopper measurements	From ratios of Au and Mo activities	
	AIR	1.04	
D ₂ O	0.94	0.94	0.89

* Compare Fig. 1.

** Normalized to the chopper value.

Results.

Absolute calibration.

In its complete form the result from a calibration is evaluated from the following expression

$$\gamma RI^{\text{Th}} + \sigma_{1/v}^{\text{Th}} = \frac{g^{\text{Th}} \sigma_o^{\text{Th}} (RI - \Delta RI + \sigma_{1/v})^{\text{Au}}}{g^{\text{Au}} \sigma_o^{\text{Au}}} \quad (4)$$

$$\cdot \frac{A_{\text{Th}}^{\text{res}} A_{\text{Au}}^{\text{th}}}{A_{\text{Au}}^{\text{res}} A_{\text{Th}}^{\text{th}}} = Cq$$

γ is the correction factor which takes into account the difference in $E \phi(E)$ at 5 eV and at the mean energy for resonance absorption in thorium. Its numerical value is 1.04 ± 0.030 .

$\sigma_{1/v}^{\text{Th}}$ is the epicadmium $1/v$ cross section of thorium, 3.05 ± 0.14 b.

g^{Th} & g^{Au} are the g factors for thorium and gold according to Westcott's nomenclature (18).

σ_o^{Th} & σ_o^{Au} are the 2200 m/s capture cross sections in thorium and uranium.

$(RI - \Delta RI + \sigma_{1/v})^{\text{Au}}$ is the effective epicadmium absorption cross section for the lead-gold foils. RI is the true resonance integral for gold, ΔRI the correction for self-shielding, and $\sigma_{1/v}$ the $1/v$ cross section.

$A_{\text{Th}}^{\text{res}}$ & $A_{\text{Au}}^{\text{res}}$ are the monitored thorium and gold activities from the central channel runs.

$A_{\text{Th}}^{\text{th}}$ & $A_{\text{Au}}^{\text{th}}$ are the activities from the thermal column runs.

$A_{\text{Th}}^{\text{res}}$ & $A_{\text{Th}}^{\text{th}}$ were counted in the same geometry and referred to the same time after reactor shut down. The same applies to $A_{\text{Au}}^{\text{res}}$ and $A_{\text{Au}}^{\text{th}}$.

To simplify the discussion, the factors on the right-hand side of Eq. (4) have been grouped together in two large factors called C and q . C depends only on cross-section data, and q is obtained from measured quantities. From Eq. (4) follows

$$RI^{\text{Th}} = (1/\gamma) (Cq - \sigma_{1/v}^{\text{Th}}) \quad (5)$$

For the factors in C, the following values have been used:

$$g^{\text{Th}} = 1.000 \quad (18)$$

$$g^{\text{Au}} = 1.005 \quad (18)$$

$$\sigma_o^{\text{Au}} = 98.8 \pm 0.5 \text{ b} \quad (15)$$

$$\sigma_o^{\text{Th}} = 7.45 \pm 0.15 \text{ b} \quad (19)$$

$$RI^{\text{Au}} = 1500 \pm 35 \text{ b} \quad (20, 21)$$

$$\sigma_{1/v}^{\text{Au}} = 42 \pm 1 \text{ b}$$

$$\Delta RI = 20 \pm 10 \text{ b}$$

The value for RI^{Au} is a mean of the calculated value $1513 \pm 60 \text{ b}$ (20) and the experimental one, $1490 \pm 40 \text{ b}$ (21). Inserted in the expression for C, the values above give

$$C = 114.4 \pm 3.5$$

The results of three independent calibrations on 20-mm diameter rods and of one on a 25-mm diameter rod are given in Table II. The table gives the q values obtained in each calibration and the values of $Cq = \gamma RI + \sigma_{1/v}$ and RI obtained from these q values according to Eqs. (4) and (5).

Relative calibration.

The results of the intercalibration are shown in Table III. Each value, y , proportional to

$$(\gamma RI + \sigma_{1/v}),$$

is a mean of several measurements. The values of y were fitted to an expression of the form

$$y = \alpha + \beta \sqrt{S/M}$$

and the parameters α and β were determined by the method of least squares. As

$$\gamma RI + \sigma_{1/v} = K(\alpha + \beta \sqrt{S/M}),$$

α and β could be transformed into absolute values with the results from the calibration on the 20-mm and 25-mm diameter rods. After subtracting $\sigma_{1/v}$ (3.05 b) and applying the flux correction, the following values of the parameters A and B in Eq. (1) were obtained

Table II.

The results of the absolute calibration.

Diam, mm	q [*]	Cq [*]	RI Th
20	0.1022 ± 2.5 %		
	0.1014 ± 2 %		
	0.1027 ± 2 %		
Mean	0.1021 ± 1.3 %	11.68 ± 3.4 %	8.30 ± 5.5 %
25	0.0967 ± 2 %	11.06 ± 3.7 %	7.70 ± 6.0 %

* For the definition of q and C compare Eq. 4 in text.

Table III.

Measured values of RI for different rod diameters

Diam, mm	S/M	$y = k (\gamma RI + \sigma_{1/v})$	RI *
4	0.932	1.729 ± 0.019	16.30 ± 0.22
6	0.761	1.519 ± 0.019	13.96 ± 0.22
9	0.622	1.320 ± 0.014	11.75 ± 0.16
15	0.482	1.106 ± 0.009	9.37 ± 0.11
20	0.417	1.000 ± 0.018	8.19 ± 0.21
25	0.373	0.951 ± 0.008	7.64 ± 0.09

* Only experimental errors included.

$$A = 1.70 \pm 0.25 b$$

$$B = 15.9 \pm 0.8 b \text{ (g/cm}^2\text{)}^{1/2}$$

The expression for the resonance integral becomes

$$RI = 1.70 + 15.9 \sqrt{S/M} \quad (6)$$

Over the measured range of S/M values, $0.14 - 0.87 \text{ cm}^2/\text{g}$, the uncertainty in RI, as calculated from Eq. (6), becomes $\pm 5.5\%$.

If the results are fitted to an expression of the form given in Eq. (2), one obtains the following values for the parameters a and b

$$a = 17.3 \pm 0.9 b \text{ (g/cm}^2\text{)}^{1/2}$$

$$b = 0.060 \pm 0.009 \text{ cm}^2/\text{g}$$

i. e.

$$RI = 17.3 \sqrt{S/M + 0.060} \quad (7)$$

The experimental points and the lines fitted to them are shown in Fig. 6.

Limits of errors.

Each q value in the absolute calibration required the measurement of six different activities, including two monitor activities. Each activity was measured several times. For the β measurements the spread in the values was generally consistent with the statistical uncertainties (about 0.5 %). The γ measurements suffered from an extra uncertainty, caused by drifts in the electronic circuits of the pulse height analyzer. This uncertainty was of the order of 1 %. Taking into account possible errors in the monitoring procedure, we deduce a standard deviation of 2 - 2.5 % for each q value.

As seen from Eq. (5) the limits of errors in the resonance integral itself will be a combination of the errors in γ , C , q and $\sigma_{1/v}$. The total standard deviation becomes 5.5 %. Uncertainties due to possible deviations of the flux from $1/E$ at high energies are not included.

For the intercalibration each γ value (compare Table III) was based on a Pa^{233} and a monitor measurement. The statistics were good also for these activities. The values in the table are means of 2 to 4 irradiations for each dimension. The uncertainties attributed to the mean values lie around $\pm 1\%$.

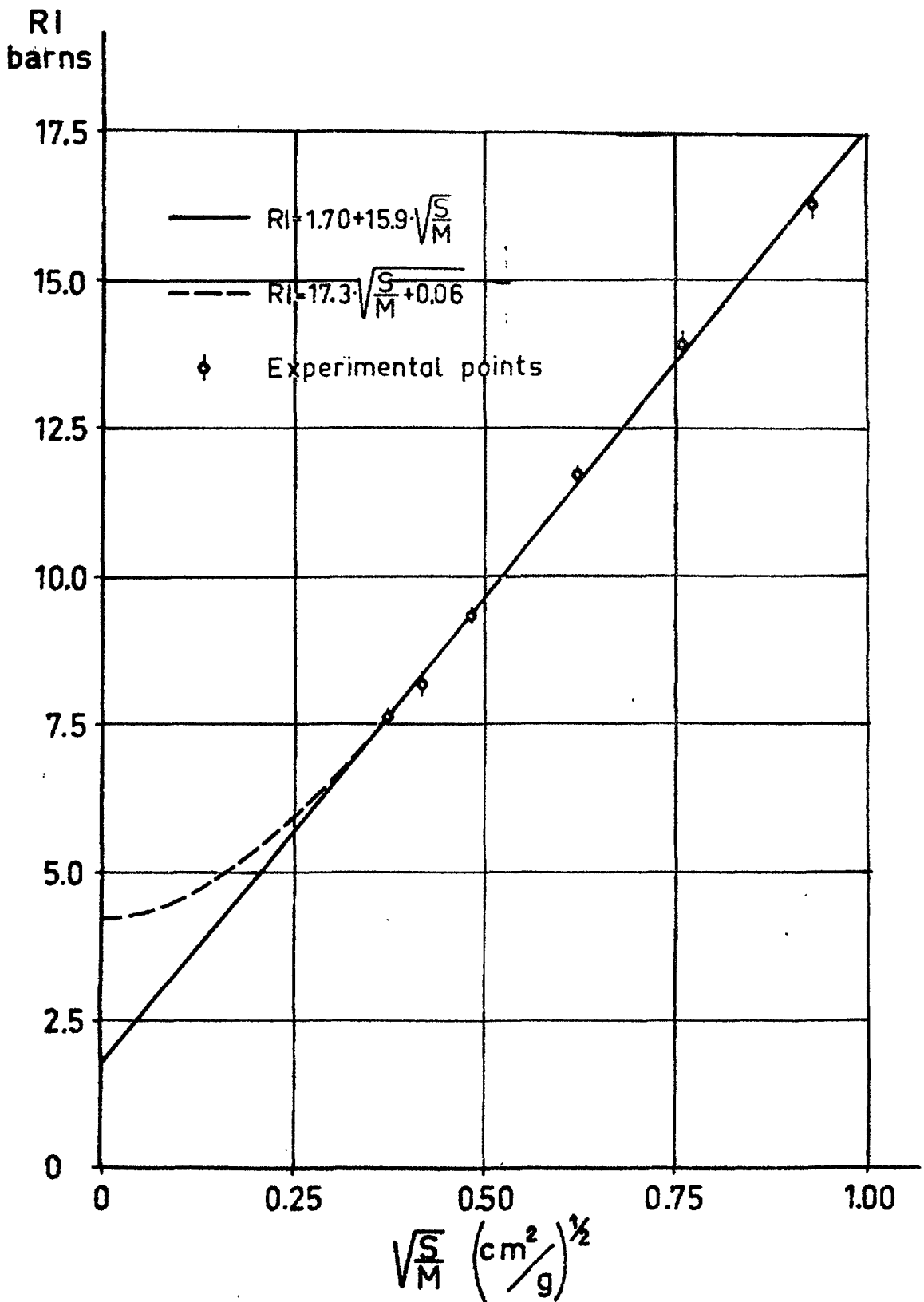

Fig. 6. The resonance integral RI as a function of $\sqrt{\frac{S}{M}}$ (the errors indicated are experimental errors only).

Discussion.

Comparison of experimental values.

In Table IV a summary of the results from different experiments has been given. In all cases the $1/v$ contribution has been removed. Before comparing the results a few comments may be made. The accuracy of I is given as not better than $\pm 20\%$. That result will, therefore, be given a low weight. For II, the calibration was based on a value of 10.9 b for the resonance integral of a 1.84-cm uranium rod. The results from more recent measurements [averaged in (22), Eq. 19, 3] indicate that this value should be lowered to about 8.8 b. From the ratio of the two uranium values a tentative renormalization factor of 0.8 may be obtained. If this factor is applied to formula number II in the table, the following expression, IIa, is obtained:

$$RI = 4.9 + 24 (S/M) - 22 (S/M)^2$$

III is evaluated from p measurements on Th-U²³⁵-H₂O systems. The water-to-metal ratio was varied between 1:1 and 4:1. Though the fuel rod diameter was constant throughout the measurements, a variation of the effective surface-to-mass ratio of the rods was obtained by the different mutual shielding of adjacent rods at different water-to-metal ratios. The effective surfaces of the rods were calculated by the Dancoff-Ginsburg method (23). The dependence of RI on S/M could then be found.

The difficulties in calculating the effective surfaces make III less accurate than the remaining expressions IV and V. Both these results are based on the boron cross section. For V gold and indium were used as additional standards.

To facilitate a comparison between the different results, the formulas IIa to VI have been graphically reproduced on Fig. 7. The range of S/M values within which each measurement was made, are, when known, marked on the figure by two labeled arrows on each curve.

As may be seen most results agree within 10-12 % for low S/M values (about 0.10 cm²/g). For larger S/M values (> 0.5 cm²/g), II ceases to be valid, and IV increasingly deviates from the other curves on account of its strong slope. Over most of the investigated S/M range only V lies below our curve. The reactivity method needs only one cross section for the absolute calibration. It is in this respect more advantageous than our method, in which three cross sections have to be used, one of which (RI^{Au}) is not known to better than 2.5 %. However, when a

Table IV.

Comparison between results from different experiments.

Author	Method	Standard	Result	Range of S/M cm ² /g
I. Untermeyer, Egger (13)	Danger coefficient	Uranium	$10 + \frac{0.55}{\frac{M}{S} + 0.08}$	0.11 - 0.48
II. Davis (12)	Period measurement	RI = 10.9 for a 1.84 cm diam. U-rod	$6.11 + 30.6 \frac{S}{M} - 27 \left(\frac{S}{M}\right)^2^*$	0.11 - 0.29
III. Sher (11)	p measurement		$2.2 + 17.1 \sqrt{\frac{S}{M}}$	~0.4
IV. Pettus (8)	Period measurement	Boron	$0.5 \pm 0.3 (21.1 \pm 1.2) \sqrt{\frac{S}{M}}$	0.10 - 0.86
V. Rothman, Ward (9)	Pile oscillator	Boron, gold indium	$-0.6 \pm 1.2 + (18.2 \pm 2.0) \sqrt{\frac{S}{M}}$	0.25 - 1.15
VI. Present report	Activation	Gold	$\left(1.70 + 15.9 \sqrt{\frac{S}{M}}\right) \pm 5.5\%$	0.14 - 0.87

* Renormalized to $4.9 + 24 \frac{S}{M} - 22 \left(\frac{S}{M}\right)^2$, compare text.

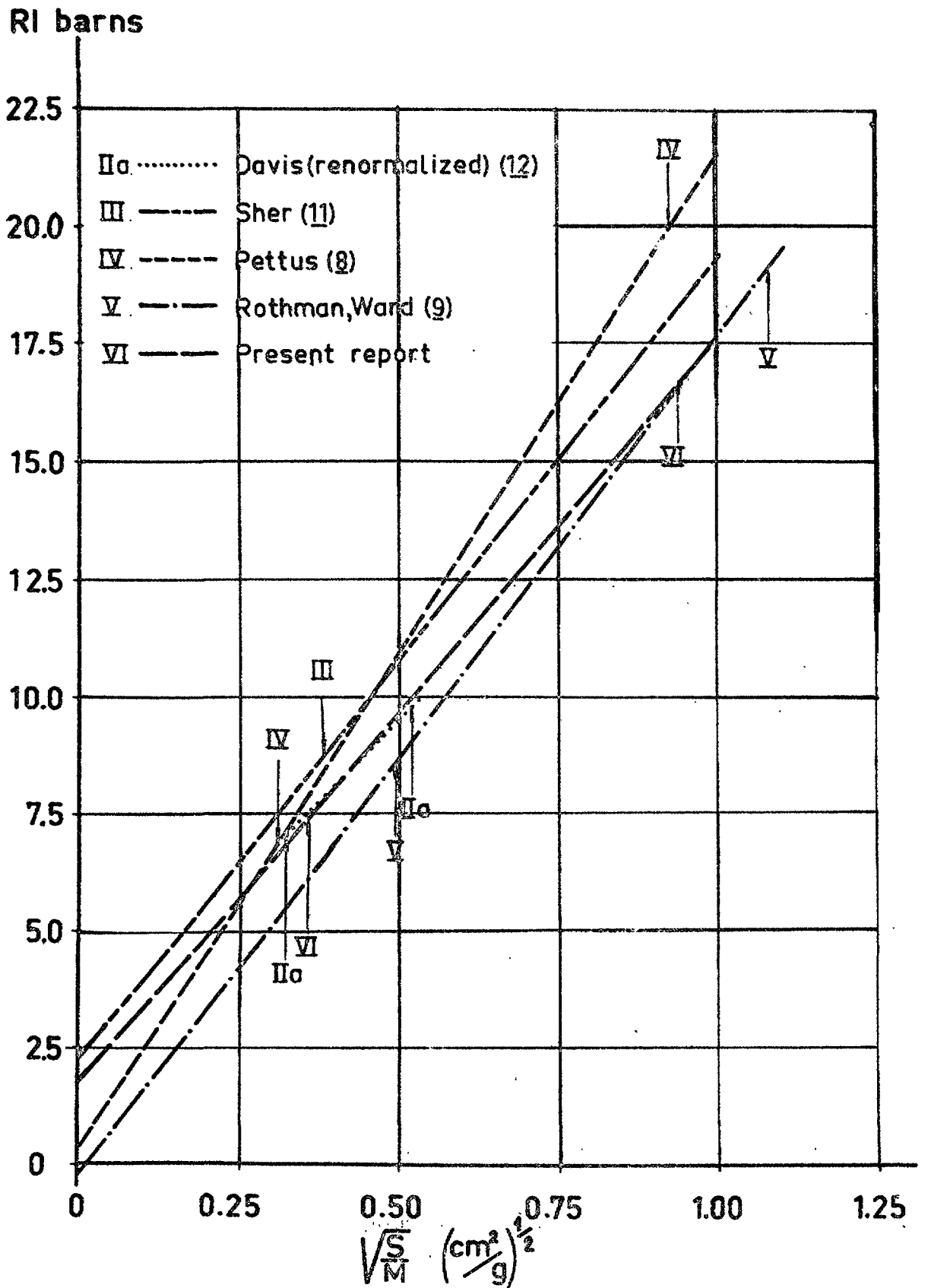

Fig. 7. Comparison between results from different experiments. The two arrows on each curve indicate the range of S/M in which the measurements have been made.

$1/v$ absorber like boron is used as a standard in reactivity work, some of the advantage is lost by the uncertainty of the effective cadmium cutoff energy. This uncertainty increases the limits of errors of the standard cross section to at least 2 %.

Various systematic effects in reactivity experiments, such as scattering, moderation, etc., due to the samples, have been separately investigated in references 8 and 9. No consideration has been taken to the effect of fast fission in thorium, however. If the measurements are made in a hard flux a non-negligible contribution to the total effect of the samples may arise from fission. The fission neutrons improve the neutron economy of the reactor and thereby cause a decrease in the absorption signal. This decrease should be approximately independent of rod size. The $\sqrt{S/M}$ dependent term would therefore not be affected, but the constant term would be too low. Some of the reactivity results also show a low value of the constant term, but if this really depends on the effect of fission neutrons is not possible to say.

Comparison with calculated values.

In Fig. 8 our measured values are compared with the results of Nordheim's (3) and Dresner's (1) calculations.

Nordheim gives the resonance integral for five rods ranging in diameters between 0.27 and 4.4 cm. The values given may quite accurately be fitted with an expression of the following form:

$$RI = 3.1 + 16.6 \sqrt{S/M} \quad (8)$$

The constant term, 3.1 b, should not directly be interpreted as the volume term for the resonance absorption in thorium rods. Nordheim has calculated this value as 5.15 b, which indicates that Eq. (8) is not a suitable form for RI at very small S/M values. On Fig. 8, therefore, a curved part with an RI intercept of 5.15 b has been substituted for Eq. (8) for small S/M values. This curved part corresponds to a function of the Vernon type.

Dresner's calculations for thorium are not so complete as those of Nordheim. He calculates RI for only two rod diameters, 0.4 and 0.9 cm and fits a straight line through the points. The equation for the line is

$$RI = 19.6 \sqrt{S/M} \quad (9)$$

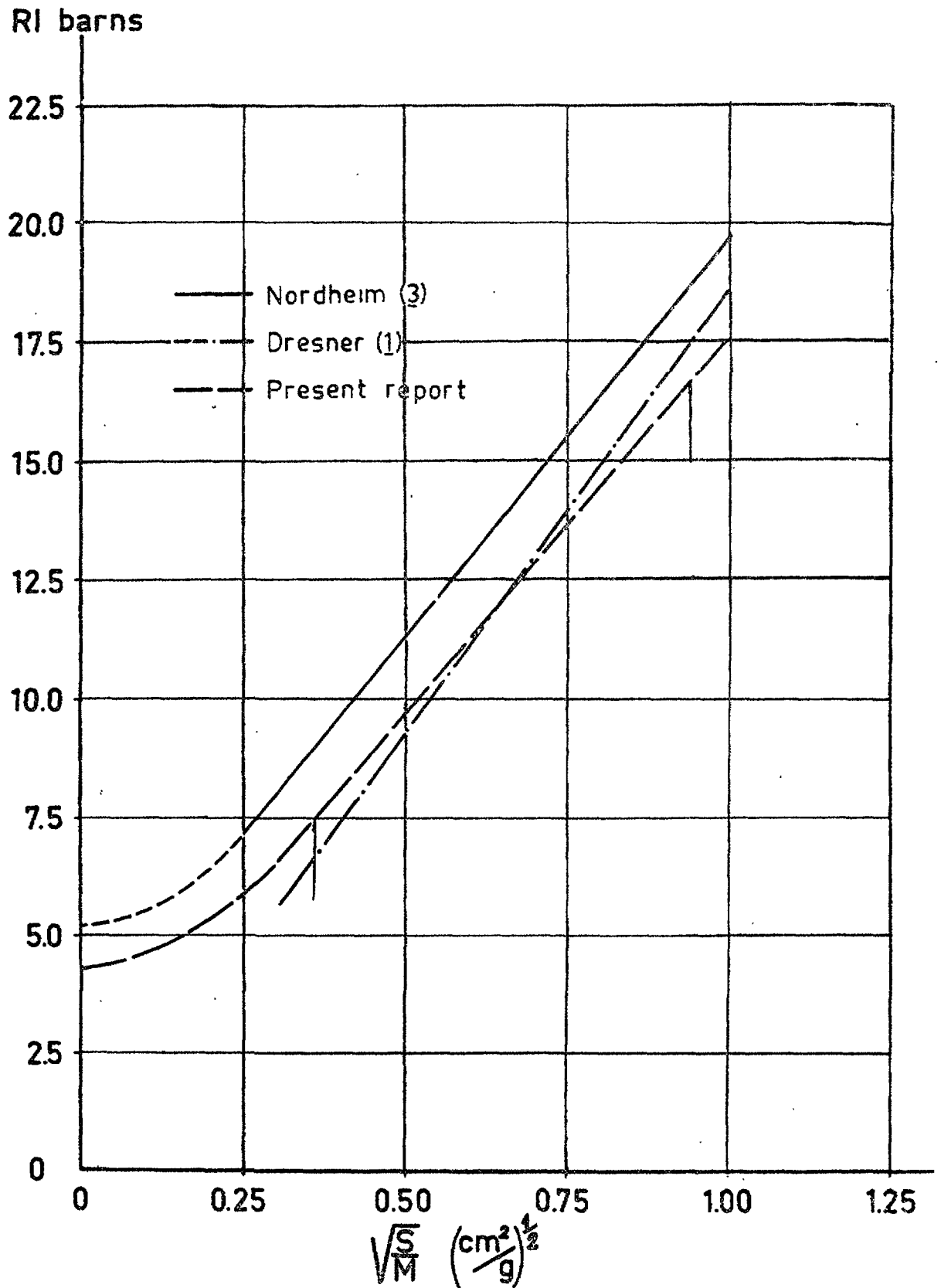

Fig. 8. Comparison between Nordheim's and Dresner's calculations and our experimental curve. The arrows on the experimental curve indicates the range of S/M in which the measurement has been made.

The absence of a constant term is a consequence of the fact that the calculation overestimates the importance of the wide resonances relative to the narrow ones. This is less important for high S/M values but gives uncorrect values of RI as S/M approaches zero.

In Dresner's calculations only s wave resonances have been considered. However, with increasing neutron energy, p wave resonances will be relatively more and more important. Chernick and Vernon (4) estimate the contribution from p waves below 30 keV as about 1.6 b for an infinitely thin sample. The estimate is based on an assumed strength function for p waves twice that for s waves. Although the validity of this assumption is uncertain and, furthermore, self-shielding of the resonances in the rods will decrease the value somewhat, the p wave contribution cannot be neglected. For energies larger than 30 keV the absorption integral in a $1/E$ flux may be calculated directly from the measured values of $\sigma(n, \gamma)$. A value of about 1 b may in this way be estimated for the energy region between 30 keV and about 500 keV (24).

To account for p wave resonances below 30 keV and the total absorption above 30 keV, Nordheim adds 2 b to his calculated values of RI. The corresponding quantity in Dresner's work is only 0.2 b, which is the s wave contribution above about 30 keV. The apparent large discrepancy between Nordheim's and Dresner's results even for large S/M values, is therefore mostly due to the different amounts added to RI for the p wave and high-energy contributions.

The experimental curve has a similar slope as the theoretical curves, but it lies considerably lower than Nordheim's curve. The discrepancy could at least partly be explained by the following facts. Firstly, as has been mentioned earlier, our results may be a few tenths of a barn too low because of deviations of the flux from $1/E$ at high energies. Secondly, the most recent data for thorium (6) give a strength function for s waves which is about 25 % lower than the value used by Nordheim in his calculation. Although the parameters for the lowest and most important resonances are unchanged, the new data for the resonances at higher energies may yield lower values for calculated resonance integrals. These effects, combined with the fact that neither of the curves is more accurate than about 5 %, makes the disagreement explicable.

For small S/M values the form given in Eq. (7) has been used to illustrate our results. Although far outside the range of S/M in which the measurements were made, the value for $S/M = 0$ comes quite close to the value calculated by Nordheim for the volume term. One obtains 4.2 b from Eq. (7) to be compared with 5.15 b from Nordheim's calculations.

Acknowledgements.

The authors are indebted to B. Karmhag and L. E. Olsson for skilful technical assistance.

References.

1. L. Dresner, ORNL-2659 (1959).
2. F. T. Adler, G. W. Hinman, and L. W. Nordheim, Proc. 2nd Intern. Conf. Peaceful Uses Atomic Energy, Geneva 16, 155 (1958)
3. L. W. Nordheim. GA-638 (1959).
4. J. Chernick and A. R. Vernon, Nuclear Sci. and Eng. 4, 649-672 (1958).
5. A. R. Vernon, Nuclear Sci. and Eng. 7, 252-259 (1960).
6. S. Desjardins, J. Rainwater, J. L. Rosen, and W. W. Havens, Jr., Tentative results of Br, I and Th neutron resonances (unpublished).
7. I. I. Gurevich and I. Y. Pomeranchouk, Proc. 1st Intern. Conf. Peaceful Uses Atomic Energy, Geneva, 5, 467-471 (1956).
8. W. G. Pettus, BAW-TM-203 (1959).
9. A. B. Rothman and C. E. W. Ward. ZPR-VII Memo-72 (ANL internal memorandum).
10. I. E. Dayton and W. G. Pettus, Nuclear Sci. and Eng. 3, 286-295 (1958)
11. R. Sher, BNL-483 (1958). Revised result quoted in ORNL-2659, 148 aa (1959).
12. M. V. Davis, J. Appl. Phys. 28, 714-716 (1957).
13. S. Untermeyer and C. Egger, ANL-4596 (1951).
14. J. P. Wilkins, CP-3581 (1946).
15. D. J. Hughes and R. B. Schwartz, BNL-325 (1958).

16. R. W. Stoughton, J. Halperin, and M. P. Lietzke, ORNL-2823 (1960).
17. E. Johansson, E. Lampa, and N. G. Sjöstrand, RFX-43 (1960). Arkiv för Fysik, no. 36, 513-531 (1960).
18. C. H. Westcott, CRRP-787 (1959).
19. R. W. Stoughton and J. Halperin, Nuclear Sci. and Eng. 6, 100-118 (1959).
20. R. L. Macklin and H. S. Pomerance, Proc. 1st Intern. Conf. Peaceful Uses Atomic Energy, Geneva, 5, 96-101 (1956).
21. K. Jirlow and E. Johansson, J. Nuclear Energy, Part A: Reactor Sci., 11, 101-107 (1960).
22. A. M. Weinberg and E. P. Wigner, "The Physical Theory of Neutron Chain Reactors," p. 661. Univ. of Chicago Press, Chicago, Illinois, 1958.
23. S. M. Dancoff and M. Ginsburg, CP-2157 (1944).
24. R. J. Howerton, UCRL-5226, I, Vol III (1959).

LIST OF AVAILABLE AE-REPORTS

Additional copies available at the library of
 AB ATOMENERGI
 Stockholm - Sweden

AE No	Title	Author	Printed in	Pages	Price in Sw. cr.
1	Calculation of the geometric buckling for reactors of various shapes.	<i>N. G. Sjostrand</i>	1958	23	3
2	The variation of the reactivity with the number, diameter and length of the control rods in a heavy water natural uranium reactor.	<i>H McCrick</i>	1958	24	3
3	Comparison of filter papers and an electrostatic precipitator for measurements on radioactive aerosols.	<i>R Wiener</i>	1958	4	4
4	A slowing-down problem	<i>I. Carlvik, B. Pershagen</i>	1958	14	3
5	Absolute measurements with a 4 π -counter. (2nd rev. ed.)	<i>Kerstin Martinsson</i>	1958	20	4
6	Monte Carlo calculations of neutron thermalization in a heterogeneous system.	<i>T. Hogberg</i>	1959	13	4
8	Metallurgical viewpoints on the brittleness of beryllium.	<i>G. Lagerberg</i>	1960	14	4
9	Swedish research on aluminium reactor technology.	<i>B. Forsén</i>	1960	13	4
10	Equipment for thermal neutron flux measurements in Reactor R2.	<i>E Johansson, T Nilsson, S. Claesson</i>	1960	9	6
11	Cross sections and neutron yields for U ²³⁵ , U ²³⁸ and Pu ²³⁹ at 2200 m/sec	<i>N G Sjostrand J. S. Story</i>	1960	34	4
12	Geometric buckling measurements using the pulsed neutron source method.	<i>N. G. Sjostrand, J. Mednis, T. Nilsson</i>	1959	12	4
13	Absorption and flux density measurements in an iron plug in R1.	<i>R Nilsson, J Braun</i>	1958	24	4
14	GARLIC, a shielding program for Gamma Radiation from Line- and Cylinder-sources	<i>M Roos</i>	1959	36	4
15	On the spherical harmonic expansion of the neutron angular distribution function	<i>S Depken</i>	1959	53	4
16	The Dancoff correction in various geometries.	<i>I Carlvik, B Pershagen</i>	1959	23	4
17	Radioactive nuclides formed by irradiation of the natural elements with thermal neutrons.	<i>K. Ekberg</i>	1959	29	4
18	The resonance integral of gold	<i>K Jirlow, E Johansson</i>	1959	19	4
19	Sources of gamma radiation in a reactor core.	<i>M. Roos</i>	1959	21	4
20	Optimisation of gas-cooled reactors with the aid of mathematical computers	<i>P. H. Margen</i>	1959	33	4
21	The fast fission effect in a cylindrical fuel element.	<i>I. Carlvik, B. Pershagen</i>	1959	25	4
22	The temperature coefficient of the resonance integral for uranium metal and oxide.	<i>P Blomberg, E. Hellstrand, S. Hörner</i>	1960	25	4
23	Definition of the diffusion constant in one-group theory.	<i>N G. Sjöstrand</i>	1960	8	4
25	A study of some temperature effects on the phonons in aluminium by use of cold neutrons	<i>K-E. Larsson, U. Dahlborg, S. Holmryd</i>	1960	32	4
26	The effect of a diagonal control rod in a cylindrical reactor	<i>T. Nilsson, N. G Sjöstrand</i>	1960	4	4
28	RESEARCH ADMINISTRATION. A selected and annotated bibliography of recent literature..	<i>E. Rhenman, S. Svensson</i>	1960	49	6
29	Some general requirements for irradiation experiments.	<i>H P. Myers, R. Skjöldebrand</i>	1960	9	6
30	Metallographic Study of the Isothermal Transformation of Beta Phase in Zircaloy-2	<i>G. Östberg</i>	1960	47	6
32	Structure investigations of some beryllium materials.	<i>I. Faldt, G Lagerberg</i>	1960	15	6
33	An Emergency Dosimeter for Neutrons.	<i>J. Braun, R. Nilsson</i>	1960	32	6
35	The Multigroup Neutron Diffusion Equations /1 Space Dimension.	<i>S Linde</i>	1960	41	6