

# THE RFQ PROTOTYPE FOR THE RADIOACTIVE ION BEAMS FACILITY AT TRIUMF

R.L. Poirier, P.G. Bricault, K. Jensen, A. K. Mitra

TRIUMF, Vancouver B.C. Canada

## Abstract

The ISAC radioactive ion beams facility being built at TRIUMF requires cw operation of a low frequency RFQ structure. This implies a large structure with adequate cooling while still maintaining mechanical alignment and stability. Our goal is to achieve a thermal stability alignment of  $\pm 0.08$  mm along the entire length of the RFQ structure and a dynamic stability of the operating assembled RFQ structure, taking into account deformation due to thermal drifts and vibrations induced by cooling and vacuum pumps, to within  $\pm 0.025$  mm. Cold model studies [1] have been carried out to confirm the RF characteristics of the RFQ design. To confirm the manufacturability of the design to maintain the above tolerances, a prototype section consisting of three RFQ rings is being fabricated and will be tested to full cw power (85 kV between electrodes). The basic design of the structure is different from other RFQ structures in that the RF surfaces have been de-coupled from the mechanical support structure for improved stability. The features of this mechanical design will be discussed and the first results of the RFQ prototype tests will be presented.

## Introduction

The accelerating system of the ISAC radioactive ion beams facility consists of an RFQ and a post-stripper DTL. Singly charged ion beams with  $A \leq 30$ , delivered from the on line mass separator with an energy of 2 keV/u, will be accelerated to 150 keV/u through the RFQ and then to a maximum energy of 1.5 MeV/u through the DTL structure. The low charge-to-mass ratio of the ions dictate a low operating frequency to achieve adequate transverse focusing, and cw operation is required to preserve beam intensity. The reference design [2] for the RFQ is a four rod split ring structure operating cw at 35 MHz with 85 kV potential between the electrodes. The RFQ accelerator section is 8 meters long and is designed in 40 cm long modules. To confirm the manufacturability of the design to maintain the tight tolerances, an RFQ prototype section consisting of three such modules is being fabricated but initial measurements are made on a single module.

## RFQ Components

Figure 1 is a sketch of one module with the major components identified. The basic design of the structure is different from other RFQ structures in that the water cooled RF skin has been de-coupled from the mechanical support structure (strongback) for improved mechanical stability. This design feature introduces an additional joint across the RF

current path at the interface of the electrode supports and the RF skin in which special care must be taken to provide a good RF contact. The first module uses an indium gasket and a groove is provided for fingerstock contacts.

## Electrodes

The electrodes (Fig. 1a) are machined from Tellurium copper which has an electrical conductivity of 93%. The electrodes are 40 cm long with a tip radius of 8.61 mm. The cross section of the electrode is shaped to provide the proper tip capacity and sufficient room for cooling channels. Two additional sample electrodes were successfully machined with the injection and extraction modulations incorporated into the tip radius.

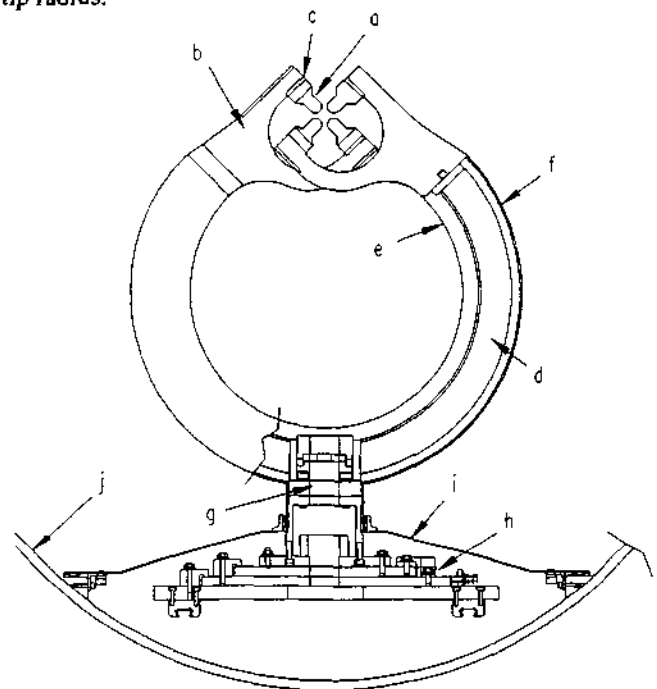

Figure 1. Sketch of one RFQ module. (a) electrodes, (b) electrode supports, (c) shims (d) strongback, (e) inner RF skin, (f) outer RF skin (g) stem, (h) adjustable base plate (i) RF shield (j) vacuum tank wall

## Electrode Supports

Tellurium copper was not readily available in the size required for the electrode supports (Fig. 1b) and were therefore NC machined from chromium copper which has an electrical conductivity of 80%. The electrode supports were complicated by a non-uniform tapered shape to maintain the

optimum structure design for maximum shunt impedance and the desire to have three separate cooling circuits (electrodes, electrode supports, RF skin) in the prototype to measure the power distribution in the RFQ module. Provision has been made for shimming (Fig. 1c) the electrodes with respect to the electrode supports.

### Strongback

The purpose of the strongback (Fig. 1d) is to provide the mechanical stability of the RFQ structure. For the prototype it was more expedient to fabricate it from aluminum but for the accelerator system it could be fabricated from carbon steel to provide added mechanical stability if necessary. The cross-section is 7.0 cm wide and a radial thickness of 4.5 cm. The outer radius of the strongback ring is 22 cm.

### RF Skin

The RF skin is fabricated from standard copper sheet. The inner RF skin (Fig. 1e) includes the side surfaces of the ring, giving it a U shaped cross-section 15 cm wide and 8 cm deep with an outer radius of 26 cm. An initial attempt to spin it from one piece of copper failed and was subsequently fabricated from three separate pieces of copper with welded joints at a radius of 19 cm on each side surface. Since the joint is in the direction of the current flow, the effect should be minimal on the losses. To ease the fabrication process the wall thickness was increased from 2.5 mm to 5 mm with the consequence of producing a much stiffer RF skin structure than initially planned. In the meantime we were successful in finding a manufacturer who was successful in spinning the RF skin from one piece of 1.75 mm thick copper sheet and the second RFQ module will incorporate this RF skin and enable us to compare the two designs. The inside surface of the RF skin is water cooled. The outer RF skin (Fig. 1f) is a simple flat copper strip 15 cm wide shaped to the outer radius of the inner RF skin with an extension at the bottom to cover the stem.

### Stem and Base Plate Assembly

The stem (Fig. 1g) is fabricated from mild steel in two sections and is nickel plated to prevent any rusting. Its main purpose is to support the weight of the RFQ structure in its proper position and provide access for the water cooling circuits.

The base plate assembly (Fig. 1h) for the RFQ prototype allows for 6 degrees of adjustment in order to have better control of the alignment for measuring misalignment effects on the RF field. The base plate assembly for the accelerator system will be greatly simplified.

### RF Skirt

The RF skirt (Fig. 1i) shields the base plate assembly and linear bearings from the RF fields. It is fabricated from standard copper sheet with finger contact at the stem and the vacuum tank wall.

### Vacuum Tank

The vacuum tank (Fig. 1j) is fabricated from copper plated mild steel with an inner diameter of 104 cm. Unfortunately a 30 cm wide strip at the top of the tank did not get copper plated and the quality of the copper plating on the rest of the tank was very poor. Also the RFQ design was based on a tank diameter of 120 cm. Both these errors will increase the RF losses in the tank wall for the prototype system.

### RFQ Measurements

Figure 2 is a photograph of the first ring installed in the vacuum tank. In order to obtain preliminary measurements the electrodes were aligned to only  $\pm 0.250$  mm but the average alignment (i.e., electrode tip capacitance) was within the  $\pm 0.08$  mm tolerance.

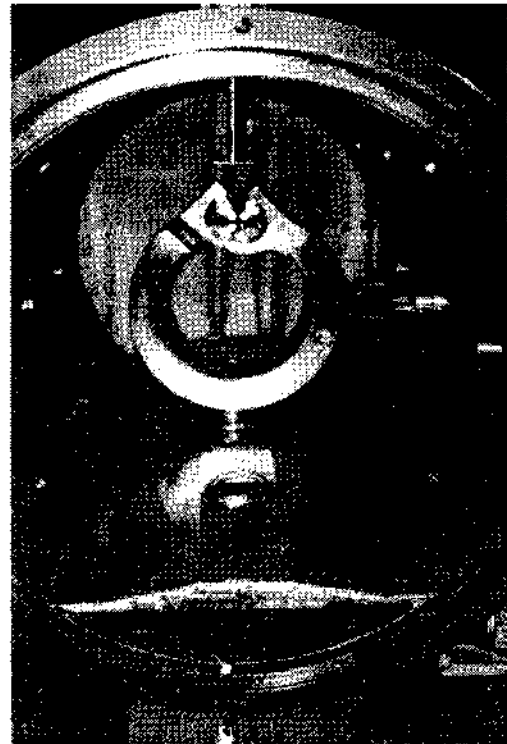

Figure 2. Photograph of first RFQ module installed in the tank.

### Signal Level Measurements

The frequency was measured to be 35.186 MHz compared to the design value of a nominal 35 MHz. Although MAFIA predicted a Q as high as 14000 for the single ring the maximum Q measured was 7200. Improving the RF contacts at the interface of the electrode/electrode support or the electrode support/RF skin did not improve the Q. Mafia predicted an R/Q of 71 ohms compared to a measured R/Q of 60.4 ohms. A shunt impedance of 435 kilohms was derived from the measured values of Q and R/Q which gives a power requirement of 8.3 kW for 85 kV at the electrodes.

## Power Level Measurements

Without the RFQ module installed, the tank vacuum was  $4 \times 10^{-7}$  torr. With the RFQ module installed, following several days of pumping, leak checking and bakeout, a vacuum of  $1.2 \times 10^{-6}$  torr was reached. By the end of two weeks of power level measurements the base vacuum was  $6 \times 10^{-7}$  torr and  $9.5 \times 10^{-7}$  torr with RF on. Full voltage was reached in 8 hours with only two minor problems; heating on the top of the vacuum tank where the copper plating was missing and production of x-rays from the walls of the ports where the material is thinner than the tank wall. A water cooling saddle was installed on the top of the tank and the port walls were wrapped with lead shielding to attenuate the x-ray radiation to acceptable working levels. A graph of the X-ray production near the window port as a function of electrode voltage is shown in Figure 3 for both cw and 20% duty cycle operation.

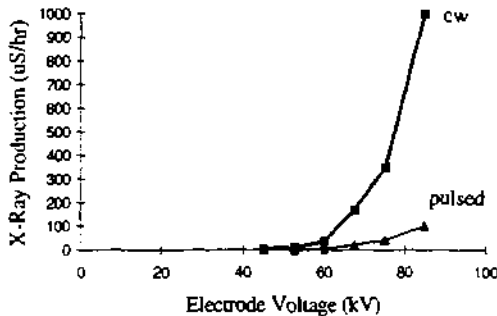

Figure 3. X-ray production near the window port.

The voltage at the gap was determined by measuring the energy of the x-rays produced and gave a power requirement of 8.0 kW for 85 kV at the electrodes, which is in very good agreement with the signal level measurement and calculation of 8.3 kW.

Thermocouples and water flow meters were installed on the return lines of the cooling circuit for the electrodes, electrode supports and RF skin. The remaining power was assumed to be dissipated in the vacuum tank wall. With proper copper plating and increased tank diameter for the actual RFQ accelerator system, the tank wall losses are expected to be much less. Table 1 is a summary of the RF power distribution.

Table 1  
RF Power distribution for the RFQ module

	Kilowatts	Percentage
Skin	3.6	45.0%
Electrode Support	1.8	22.5%
Electrode	1.2	15.0%
Tank wall	1.4	17.5%
Total	8.0	100%

The frequency of the RFQ decreases by 36 kHz from signal level to full power (see figure 4). The thermal movement of the electrodes from signal level to full power was measured by

observing the position of the electrodes with a theodolite. A movement of less than  $\pm 0.050$  mm was observed when the voltage was slowly increased to 85 kV and no dynamic movement ( $< \pm 0.25$  mm) was observed due to cooling water or vacuum pumps. When the voltage was instantaneously applied a movement of approximately 0.200 mm was observed by each pair of the same polarity electrodes in the direction away from the beam centre, but returned to its aligned position within three minutes.

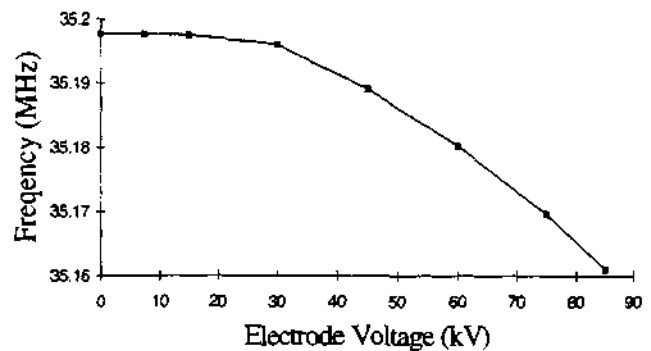

Figure 4. Frequency change as a function of electrode voltage.

The effect of slowly shutting off the water cooling to the electrodes was a decrease in frequency of 18 kHz with no observable movement of the electrodes.

## Conclusion

Despite the design changes which had to be incorporated for manufacturability, the design feature of de-coupling the water cooled RF skin of the ring from the mechanical strongback structure was successfully fabricated and a stable RFQ module was produced. Our thermal and dynamic stability tolerances of  $\pm 0.08$  mm and  $\pm 0.0250$  were achieved. The RF specifications of 85 kV between electrodes at 35 MHz was also achieved.

Plans are already in progress to simplify the RFQ design to reduce the cost.

## Acknowledgment

There are many people who helped to achieve the above results. A special thanks to Bill Uzat who designed and built the RF amplifier, Bhalwinder Waraich, Peter Harmer and John Tanguay who did a tremendous job with the mechanical assembly and Vijay Verma who was a tremendous help in scheduling, planning and expediting.

## References:

- [1] P.G. Bricault, Dave Joffe and H.R. Schneider, "RFQ Cold Model Studies", Proc. 1995 Particle Accelerator Conf. and Int. Conf. on High-Energy Accelerators, p1122 (1995)
- [2] P.G. Bricault and H. R. Schneider, "Simulation of the TRIUMF Split Ring 4-Rod RFQ with MAFIA", Proc. 1995 Particle Accelerator Conf. and Int. Conf. on High-Energy Accelerators, p1125 (1995)