

# The Fusion Advanced Studies Torus (FAST): a Proposal for an ITER Satellite Facility in Support of the Development of Fusion Energy

A. Pizzuto 1) on behalf of the Italian Association

1) Associazione EURATOM-ENEA, CR ENEA Frascati, C.P. 65, 00044 Frascati, Rome, Italy

e-mail contact of the first author: [Pizzuto@frascati.enea.it](mailto:Pizzuto@frascati.enea.it)

**Abstract.** FAST is the conceptual design for a new machine proposed to support ITER experimental exploitation as well as to anticipate DEMO relevant physics and technology. FAST is aimed at integrated investigations of fast particle physics, plasma operations and plasma wall interaction in burning plasma relevant conditions. In Deuterium plasma operations, FAST has the capability to simultaneously approach relevant dimensionless physical parameters in all the ITER scenarios. The necessity of achieving ITER relevant power densities and performance with moderate cost has led to a compact Tokamak design ( $R=1.82$  m,  $a=0.64$  m), with a high toroidal field ( $B_T$  up to 8.5 T) and plasma current ( $I_p$  up to 8 MA). In order to study fast particle behaviours with dimensionless parameters similar to ITER, the project is based on a dominant Ion Cyclotron Resonance Heating system (ICRH; 30 MW coupled to the plasma). Moreover, the experiment foresees 6 MW of Lower Hybrid (LH), essentially for plasma control and for non-inductive current drive, and of Electron Cyclotron Resonance Heating (ECRH; 4MW) for localized electron heating and plasma control. Ports have been designed to also accommodate up to 10 MW of negative neutral beam injection (NNBI) in the energy range of 0.5-1 MeV. The total power input is in the 30-40 MW range in the different plasma scenarios, with a wall power load comparable with that of ITER ( $P/R \sim 22$  MW/m). All ITER scenarios can be studied: starting from the reference H-mode, with plasma edge and ELMs characteristics similar to those of ITER ( $Q$  up to  $\sim 2.5$ ), and arriving to full non-inductive current drive scenarios lasting  $\sim 160$  s. Under these conditions, first wall as well as divertor plates will be made of tungsten. The divertor itself is designed to be completely removable by remote handling. This will allow studying, in view of DEMO, the behaviour of innovative divertor concepts, such as those foreseeing the use of liquid lithium. FAST is capable to operate with very long pulses, up to 170 s, despite being a copper machine. The magnets initial operation temperature is 30 K and the cooling is ensured by helium gas. The in vessel components, namely first wall and divertor, are actively cooled by pressurised water at 80 °C. The same water is also used for vacuum vessel baking. FAST is equipped with ferromagnetic inserts to keep the toroidal field magnet ripple as low as 0.3%.

## 1. Introduction

It has widely been accepted that successful ITER exploitation and early and reliable DEMO design will require a strong physics and technology accompanying program. A key point of this program is the construction and exploitation of one or more satellite Tokamak experiments. ITER will investigate rich complex physics and technical unexplored problems in a nuclear environment. Consequently, for the full success of ITER and to prepare DEMO solutions as soon as possible, satellite Tokamak experiments are mandatory. However, it is not obvious how to define and to correctly prioritize what the actual ITER needs are. Some apparently conflicting aspects must be carefully analyzed and solved. A Satellite should cost a small fraction of the total ITER cost, but, at the same time, should be able to explore all ITER relevant scenarios and, for each of these, should have the flexibility to “reproduce” ITER experimental conditions as close as possible, in order to investigate the relevant physics issues in an integrated fashion, to anticipate potential problems and/or unexpected issues and to propose timely solutions, with the obvious advantage of expediting the ITER scientific exploitation and amplifying its achievements. The FAST proposal aims at indicating a possible path to solve these issues, showing that the preparation of ITER scenarios and the development of new expertise for DEMO design and R&D can be effectively implemented, in

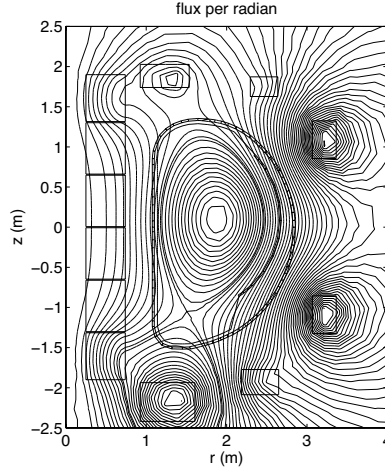

FIG. 1. FAST Equilibrium and Poloidal System

an integrated fashion, on a new facility that: a) will work with Deuterium plasmas, avoiding the problems associated with the use of Tritium, and will investigate non linear dynamics that are relevant for the understanding of alpha particle behaviours in burning plasmas by using fast ions accelerated by heating and current drive systems; b) will work in a dimensionless parameter range close to that of ITER; c) will test technical innovative solutions for the first wall/divertor directly relevant for ITER and DEMO, such as full-tungsten plasma facing components and advanced liquid metal divertor target; d) will exploit advanced regimes with long pulse duration with respect to the current diffusion time and up to full non-inductive current driven (NICD) scenarios; e) will serve as test bed for ITER and DEMO diagnostics; f) will provide an ideal framework for model and numerical code benchmarks, as well as verification and validation in ITER and DEMO relevant plasma conditions [1-7].

## 2. Plasma Physics Scenarios

The FAST poloidal system and all plasma equilibria have been designed to be as much as possible self-similar to those of ITER (FIG.1). Moreover, all experimental scenarios assume the same Plasma shape [3] with  $R=1.82$  m,  $a=0.64$  m, elongation  $K=1.7$ , triangularity  $\langle\delta\rangle=0.4$  and plasma volume of  $\sim 23.5$  m<sup>3</sup>. This similarity of all plasma equilibria, in different plasma scenarios (high and low  $\beta$ , high and low  $I_p$ , monotonic or hollow q profile, etc.), can be achieved thanks to an advanced plasma shaping control system recently developed at JET [3]. In all configurations an energy decay length  $\lambda_E \sim 0.5$  cm has been assumed at the plasma equatorial plane [4] and a minimum distance  $6 \lambda_E$  has been assumed between the last closed magnetic surface and the first wall. The natural toroidal ripple would be of the order of 2%; however, the use of ferromagnetic inserts or of innovative active ripple control (by small active coils located just in front of the outer part of toroidal coils) [3,7] allows reducing the maximum toroidal ripple to less than 0.3%.

The remarkable FAST flexibility is evidently shown in TABLE I, where the main plasma scenarios are illustrated. Two different H-mode scenarios are reported. In the second column, the scenario is aimed at achieving the highest performance ( $Q \sim 2.5$ ) with toroidal field  $B_T=8.5$ T, plasma current  $I_p=8$ MA, large average plasma density  $\langle n_e \rangle = 0.8 n_{\text{Greewald}} = 5 \times 10^{20}$  m<sup>-3</sup> and assuming 40 MW of additional heating (30 MW ICRH + 10 MW NNBI). As a consequence of toroidal magnet heating, this regime can only be sustained transiently ( $\tau_{\text{FlatTop}} \sim 2$  s  $\sim 4\tau_E$ ). A longer H-mode scenario ( $\tau_{\text{FlatTop}} \sim 13$  s  $\sim 2 \tau_{\text{Res}}$ ) is shown in the first column. This is the reference H-mode scenario because it is conceived for integrated studies of burning plasma physics and their complex behaviours [8,9]. In ITER, the main heating source will be

TABLE I: OPERATING SCENARIOS.

FAST	H-mode reference	H-mode extreme	Hybrid	AT	AT2	Full NICD
$I_p$ (MA)	6.5	8.0	5	3	3	2
$q_{95}$	3	2.6	4	5	3	5
$B_T$ (T)	7.5	8.5	7.5	6	3.5	3.5
$H_{98}$	1	1	1.3	1.5	1.5	1.5
$\langle n_{20} \rangle$ ( $m^{-3}$ )	2	5	3	1.2	1.1	1
$P_{th_H}$ (MW)	14 ÷ 18	22 ÷ 35	18 ÷ 23	8.5 ÷ 12	5 ÷ 7	5 ÷ 7
$\beta_N$	1.3	1.7	2.0	1.9	3.2	3.4
$\tau_E$ (s)	0.4	0.65	0.5	0.25	0.18	0.13
$\tau_{res}$ (s)	5.5	5	3	3	5 ÷ 6	2 ÷ 5
$T_0$ (keV)	13.0	9.0	8.5	13	13	7.5
$Q$	0.65	2.5	0.9	0.19	0.14	0.06
$t_{discharge}$ (s)	20	13	20	70	170	170
$t_{flat-top}$ (s)	13	2	15	60	160	160
$I_{NI}/I_p$ (%)	15	15	30	60	80	>100
$P_{ADD}$ (MW)	30	40	30	30	40	40

provided by fusion  $\alpha$  particles that will deliver  $\sim 70\%$  of the energy to electrons. Some of the main burning plasma physics issues due to the presence of significant populations of high energy fast particles, such as fusion  $\alpha$  particles and supra-thermal fast ion tails due to ICRH and/or NNBI, can be addressed in a pure D plasma, provided that fast particle populations have specific features [5,8,9]; in particular: a) fast ions must predominantly heat electrons; b) the fast ion induced fluctuation spectrum must be preserved in mode number ( $\rightarrow \rho_{H}^* \sim \rho_{H,ITER}^*$ ) and frequency ( $\rightarrow (\omega_H/\omega_A) \sim (\omega_H/\omega_A)_{ITER}$ ); c) the strength of the wave-particle interaction must be preserved ( $\rightarrow \beta_H \sim \beta_{H,ITER} \Leftrightarrow (\tau_{SD}/\tau_E) \sim (\tau_{SD}/\tau_E)_{ITER}$ ). Here,  $\rho_{H}^*$  is the energetic particle Larmor radius normalized to the torus minor radius,  $\omega_H$  is the characteristic frequency associated with fast ion motions and  $\omega_A = v_A/qR$  is the Alfvén frequency; other notations are standard. In a satellite conditions a),b),c) must be produced in ITER relevant dimensionless parameter regimes for the thermal plasma (core and edge), in order to address burning plasma complex behaviours in integrated scenarios, which, in the case of FAST, will be realized in ITER relevant regimes from the performances point of view ( $Q \sim 1$ ). Under these conditions, fast ion transport due to collective mode excitations and cross-scale couplings of micro-turbulence with meso-scale fluctuations due to energetic particles themselves can be addressed. When translated into macroscopic machine parameters, the above conditions lead to plasma parameters comparable to the parameters of the first column of TABLE I:  $B_T = 7.5T$ ,  $I_p = 6.5MA$ ,  $T(0) = 13keV$  and  $\langle n_e \rangle = 0.5 n_{Greenwald} = 2 \times 10^{20} m^{-3}$ , with an effective ICRH induced supra-thermal  $^3He$  tail temperature  $\sim 0.7 MeV$ . The simultaneous use of the JETTO transport code (with a mixed Bohm-GyroBohm transport model), coupled with the full wave electromagnetic codes TORIC and SSQLFP, has allowed to simulate the scenario evolution

Table III – Comparison of main fast design parameters with those of other major experiments

	FAST	JET	JT60-SA	ITER
R(m)/a(m)	1.82/0.64	3.0/1.0	3.0/1.0	6.2/2.1
B(T)	7.5	3.9	2.7	5.3
$I_p$ (MA)	6.5	3.9	5.0	15
$P_{ICRH}$ (MW)	30	12	0	20
$P_{NNBI}$ (MW)	0 (10)	0	10	40
$P_{PNBI}$ (MW)	0	25	24	0
$P_{ECRH}$ (MW)	4	0	7	20
$P_{LH}$ (MW)	6	3	0	20 tbd
P/R(MW/m)	22	13	14	24
$t_R$ (s)	5–6	7–8	8-9	80–90
$t_{flat-top}$ (s)	13	10	100	400

from the ohmic phase to full power injection, assuming 30 MW of ICRH under an  $^3\text{H}_e$  minority ( $\sim 1\%$ ) heating scheme [5]. Simulation results demonstrate that plasma temperature and density of TABLE I can be achieved with standard H mode profiles. Up to 50% of the minority ( $n_H \sim 5 \cdot 10^{-3} \langle n_e \rangle$ ) is brought in the very high energy tail of the distribution function, achieving a peak perpendicular temperature of  $\sim 0.8$  MeV, with  $\rho_{*H}$  and peak  $\beta_H$  close to ITER values ( $\rho_{*H-FAST}^* = 2.6 \times 10^{-2}$  vs.  $\rho_{*H-ITER} = 2.5 \times 10^{-2}$ ;  $\beta_{H-Fast} = 0.7\%$  vs.  $\beta_{H-ITER} = 1\%$ ). Note that, also in this scenario, 4 MW of ECRH (170 GHz -  $B_T=6\text{T}$ ) are available for the control of MHD instabilities in the region around half plasma radius (safety factor  $q=2$ ). A preliminary analysis of the global MHD stability for the long pulse AT scenarios has been performed, using the MARS code in order to investigate the possibility of stabilizing Resistive Wall Modes (RWM). The no-wall beta limit, corresponds to  $\beta_{Nc}=2.8$  for a 6 MA plasma at 6.7T, whereas an ideal wall at  $r/a=1.3$  has  $\beta_{Nc}=3.24$ .

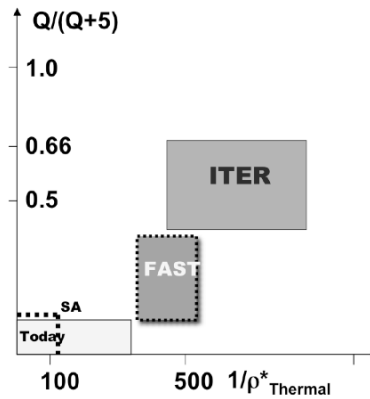

FIG. 2. FAST compared with ITER and existing experiments in terms of dimensionless parameters

Three different solutions are addressed in TABLE I for advanced scenarios studies. In all these scenarios, a slightly hollow q profile has been assumed with minimum  $q \sim 2$  at around half plasma radius. Moreover, for all of them the standard assumption of  $\tau_E \sim 1.5 H_{98}$  improved confinement has been done. In the first scenario (AT), the possibility to do experiments at relatively high toroidal field ( $B_T = 6T$ ) is illustrated. This hypothesis presents several advantages, e.g., higher performances and better flexibility of the control systems: LHCD has better accessibility; the ECRH system can easily be used for central heating or for half radius MHD control. However, this scenario has also the drawback of lower  $\beta_N (< 2)$  and of a non-optimized duration of the discharge ( $\sim 70s$ ). The other two options, shown in the table, assume lower toroidal field ( $B_T = 3.5T$ ) and, consequently, it is possible to achieve larger  $\beta_N (> 3)$  and long discharge duration ( $\sim 170s$  with  $\tau_{FlatTop} > 30 \tau_{Res}$ ) in both cases. The main difference between these two scenarios consists essentially in the full NICD configuration achieved in the last one, where  $I_{Bootstrap} \sim 60-70\%$  and  $I_{LHCD} \sim 30-40\%$ . The bootstrap current and the LH driven current are well aligned; LHCD can also be used as plasma current profile control tool. It should be noted that 6 MW of LHCD are foreseen in both these scenarios, with a frequency not yet fixed (3.7 or 5 GHz). Moreover, the 4 MW of ECRH can be used in second harmonic for central plasma heating (given the large Shafranov shift due to high  $\beta$ ) and/or MHD control [3].

In TABLE II, the main FAST technical features are compared with the nominal values of some present (JET) and future experiments (ITER, JT60-SA), showing the remarkable flexibility of FAST for approaching ITER scenarios. Translating these machine parameters into dimensionless quantities, one can note (FIG.2) that FAST will fill in a large gap existing between the present tokamak operations and ITER.

### 3. Power Handling

The crucial aspects of thermal loads on divertor plates and of core plasma purity are governed by the complex relationships binding plasma core and edge. In order to have reliable predictions, a series of calculations has been performed in the framework of models aimed at describing plasma core and edge self-consistently. A two steps route of increasing accuracy and calculation complexity has been followed. First, a simple model, based on 0D description of the plasma parameters in the core and on a two-point model for the plasma scrape-off layer (SOL), has been used to investigate the wide range of plasma parameters in FAST. Then, the more complex code COREDIV [4] (1D in the bulk and 2D in the SOL) has been used when some specific questions dealing with plasma performance and/or heat removal from the divertor needed to be addressed in more detail, or when the estimated core-edge coupling was so strong to make the simple model predictions scarcely reliable. Both models have been validated in the past on JET, FTU and TEXTOR experimental data. Several self-consistent numerical simulations have been made for the H-mode and AT scenarios. The calculations have been carried out first for a full W machine, then the option of injecting Ar and Ne to mitigate thermal loads has been considered and, finally, the DEMO relevant with liquid lithium as divertor target has been analyzed. Simulation results with COREDIV show that the thermal power loads can be contained within ITER relevant limits for all FAST scenarios, i.e.  $18 \text{ MW/m}^2$ , by suitably small impurity seeding and/or operation regimes at appropriate plasma density. Moreover, in all cases the effective ion charge  $Z_{eff}$  remains sufficiently low ( $< 2$ ) as a consequence of the high edge density and of the low temperature at the plates.

ELMs are one of the major “concerns” intrinsically connected with the “standard” H Mode scenario. Since FAST reference scenarios rely on good quality ( $H_{98}=1$ ) H mode, a noticeable ELMs activity is expected in FAST as in ITER. Consequently, it is important to understand what type of ELMs are expected, verify their compatibility with machine plasma

facing components (PFCs) and to optimize plasma operations. As working paradigm we adopt usual assumptions from the present available literature. In a good quality H Mode, the plasma pedestal energy energy confined is proportional to the total plasma energy ( $W_{\text{PED}} \sim 40\% W_{\text{TOT}}$ ). Meanwhile, the energy released by single ELMs is proportional to the pedestal energy and the proportionality coefficient depends on the pedestal collisionality ( $W_{\text{ELM}}/W_{\text{PED}} = F(v^*_{\text{PED}})$ ); in particular, for  $v^*_{\text{PED}} \approx 0.1 \rightarrow W_{\text{ELM}}/W_{\text{PED}} \approx 0.15$ . From the analysis of present database, it can be assumed that the power released by ELMs is  $P_{\text{ELM}} \approx 50\% P_{\text{IN}}$ , with  $P_{\text{IN}}$  the total injected power. Furthermore,  $P_{\text{ELM}} = f_{\text{ELM}} W_{\text{ELM}}$ , where  $f_{\text{ELM}}$  is the ELM frequency. Using these assumptions for the scenario at  $I = 6.5$  MA in TABLE II, but considering lower density of  $n/n_{\text{GW}} \approx 0.3$ , meaning low edge collisionality ( $v^*_{\text{PED}} \approx 0.1$ ), ELMs energy and frequency are respectively:  $W_{\text{ELM}} \approx 1.5$  MJ and  $f_{\text{ELM}} \approx 10$  Hz. For a preliminary assessment of divertor heat loads by ELMs, we assume that the fraction of this energy mostly contributing to material damage, i.e. that deposited on short timescales, is about 40% for low collisionality. By assuming the same spatial deposition profile as for inter-ELM and a factor 2 asymmetry in the in-out ELMs energy deposition, the energy density on the inner divertor is expected to be about  $1.0 \text{ MJm}^{-2}$ ; this value is to be compared with the threshold for damage ( $0.3 \text{ MJm}^{-2}$ ), scaled from the one adopted by ITER for avoiding too strong W erosion. It is important to note that this low collisionality regime is achieved in conditions of high density ( $n_{\text{EDGE}} \approx 10^{20} \text{ m}^{-3}$ ), comparable with that of ITER, as it is the case for the edge temperature too. Consequently, this experiment will actually have ITER relevant edge conditions and will allow studying and optimizing edge conditions in order to mitigate ELMs impact on machine operations. The large range of achievable densities will also allow operating at higher collisionality with much lower ELMs amplitude. Moreover, the machine will have the possibility to use different divertor materials; in particular, it envisages the use of liquid lithium that could significantly improve pedestal parameters and machine performance. A variable  $n$  ( $1 \Rightarrow 3$ ) active coils system to control ELMs amplitude by edge ergodization is foreseen to inside the machine. Moreover, the vertical control system [3] has been designed with the capability of providing a wide range of plasma kicking frequencies for “controlling” ELMs amplitude and repetition rate.

#### 4. The additional radiofrequency heating systems for FAST

Three auxiliary radiofrequency (RF) heating systems have been foreseen for FAST [10].

The ICRH system will couple RF power up to 30MW to the plasma in the 30–90 MHz frequency range. The system works in pulsed regime with pulse length up to 150s at full power; the time interval between two successive 150s pulses is about 2 hours. The ICRH launcher is based on an array of eight (2 toroidal by 4 poloidal) current straps, each fed through a  $6\frac{1}{8}$  30 $\Omega$  coaxial cable. Ceramic feedthroughs delimit both ends of the vacuum part of the transmission line close to the FAST vacuum vessel. The average equivalent resistance of a strap is about 2 $\Omega$ . The necessary impedance matching between coaxial cable and elemental current straps it is obtained by external conjugate-T matching units. A Faraday Shield (FS), made by a set of 30 untitled elements with smoothed rectangular cross section, protects the electrically active components of the launcher from direct contact with the plasma and suppresses the components of the emitted radiation parallel to the local B-field. All the launchers components (straps and FS rods) are water-cooled. A maximum RF power of about 7 MW can be safely coupled to the plasma by each array at 80MHz, with a distance of 3 cm between antenna mouth and boundary. The maximum power density is about  $10 \text{ MW/m}^2$  at the antenna mouth.

The ECRH system it is made by four identical units, each including a high power RF source, a transmission line and a launcher. The high power RF source is a 170GHz/1MW depressed collector gyrotron, derived from the R&D activities for ITER, working in pulsed regime with pulse length up to 200s. Each gyrotron is fed by a 55kV/50A High Voltage Power Supply (HVPS), whose output can be modulated on-off with a modulation frequency up to 10 kHz. The HVPS is designed as actuator in the feedback loop for MHD mode suppression.

FAST also foresees 6MW of LHCD in pulsed regime (pulse length up to 160s), so far at a frequency of 3.7GHz. This choice was suggested by already existing high power CW sources, i.e. the TH 2103 klystron, rated at 500kW/CW and 650kW/10s. A backup solution at the more efficient 5GHz frequency has also been studied and could be adopted if suitable klystrons will be available in the near future. The system is split in four independent modules; each module including 4 klystrons fed by a single HVPS (70kV, 100A dc).

## 5. FAST Load Assembly

FAST Load Assembly consists of 18 Toroidal Field Coils (TFC), 6 Central Solenoid (CS) coils, 6 external poloidal coils (3+3), Vacuum Vessel (VV) with its internal components and the mechanical structure. Resistive coils, adiabatically heated during the plasma pulse, are cooled down at cryogenic temperatures (30 K) by helium gas [12]. The cooling of the rest of the machine is guaranteed by good thermal contacts between major components. The VV is maintained at  $\sim 100$  °C by a dedicated system. The load assembly is kept under vacuum inside a stainless steel cryostat providing machine thermal insulation. The overall cryostat dimensions could be assimilated to an 8 m diameter 6 meter high circular cylinder (FIG. 3). FAST is a flexible device in terms of both performance and physics that is able to operate in H-mode reference scenario (6.5MA/7.5T) as well as in advanced tokamak regimes (AT2). The worst thermal conditions are reached after a long current pulse (170s in AT2), in which the toroidal coils temperature reaches  $\sim 150$ K in the leg region. The poloidal coil system reaches a maximum temperature of 85K. The cooling of the magnet system is globally guaranteed by a 30K helium gas flow of about 4 kg/s, supplied from a cryo-cooler through suitable channels carved in the coil turns. Each TF it is contained by a stainless steel belt fitted to the outside zone of the coil. Two pre-compressed rings, situated in the upper-lower zone, keep the whole toroidal magnet structure in wedged configuration. TF magnet ripple is limited to 0.3% at the plasma separatrix with optimized ferromagnetic inserts.

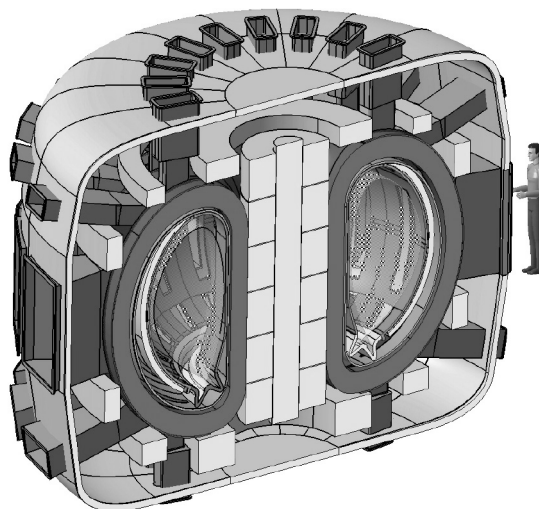

FIG. 3. FAST Load Assembly view

The VV is supported through equatorial ports by means of brackets attached to the TF coil case. The First Wall (FW) consists of a bundle of tubes armoured with  $\sim 4$  mm tungsten plasma spray. The divertor technology is the monoblock type, which has been tested at high heat flux values. Moreover, development of innovative lithium divertor concept are foreseen and encouraged by successful tests of a liquid lithium capillary-pore limiter in FTU [11].

Neutron emissivity sources ( $n/m^3s$ ) and neutron rates ( $n/s$ ) foreseen for the H-mode and the AT scenarios have been calculated considering, for each scenario, the equilibrium configuration, the ion temperature and density profiles, and a maxwellian DD reactivity. The MSST (Measurement Simulation Software Tool) code was used for this purpose, after tests on FTU have shown an agreement with the measured neutron rate within 10%. The calculated neutron rates for FAST show neutron yields that vary from a minimum of  $0.7 \times 10^{17}$  n/shot to a maximum of  $2.2 \times 10^{17}$  n/shot, respectively for AT scenarios and the H-mode extreme. The experimental agenda foresees 800 shots for a total of  $1.6 \times 10^{21}$  n.

The short/medium term activation is not negligible (for example, 12 days after shutdown the contact dose rate is  $< 10$  mSv/h on the vacuum vessel, but it reaches  $\sim 170$  mSv/h on the first wall due to tungsten activation) and therefore remote handling is mandatory.

## 6. Diagnostics

Several diagnostics already foreseen for ITER can be developed and exploited in FAST. In particular, the diagnostics dedicated to confined and lost fast particles dynamics studies and to the divertor behaviour investigations are in a preliminary phase of development and need a dedicated program in order to be ready for ITER. Other systems are still under discussion because feasibility studies are still in the early development phase (erosion and dust monitors for example). FAST is a device suitable for developments of advanced diagnostics useful for ITER and candidate systems for DEMO for the following reasons:

1. device flexibility in terms of testing different technical solutions to optimize diagnostic performance;
2. reduced optimization time due to fewer operational constraints, for example in the scheduling of diagnostic system commissioning.
3. reduced costs and development time of the diagnostics, as FAST works in D with W wall, problems and cost related with the use of tritium and beryllium are avoided.

The diagnostic systems have been conceived to provide measurements for the characterization of fast particle dynamics as well as for the monitoring relevant thermal plasma component physics quantities in H-mode and AT scenarios. There are five main diagnostics groups: 1) burning plasma; 2) kinetic parameters and current profile; 3) magnetics; 4) SOL and divertor; 5) turbulence and radiation emission. Within each group, three levels of importance can be identified:

- standard: Conventional systems, which require no or marginal R&D and will be installed at  $t=0$ ;
- first priority: Diagnostics that are necessary to achieve FAST missions and can be installed after few years of operation;
- R&D needed: Systems that are important for FAST missions as well as for all burning plasma experiments, requiring additional R&D and for which FAST can represent an optimal test bed in view of ITER applications.

## 7. Cost and Schedule

The total updated investment cost of the has been estimated to be less than 300 M€, plus 45-50 M€ for infrastructures. This estimate assumes that some of the heating systems



can be re-utilized from existing hardware, e.g. the lower-hybrid system. The diagnostic R&D are included. A dedicated team of 120 PY is foreseen. The annual operation cost is estimated in 13.5 M€/y plus 150 PY, considering 1500 shots (800 of which are performance shots, 20s each) and 150 operation days. The assumed operation team is 150 PPY. It should be noted that about half of this budget would be eventually covered by the present FTU and RFX operation costs. It is worthwhile comparing FAST construction and operation costs with those of ITER: the average cost/shot is ~ 60 times higher in ITER than in FAST (~500 k€ against ~8k€), while construction costs are > 20 higher in the ITER case, with FAST construction costs roughly corresponding to 500 ITER shots. These figures demonstrate that it is advantageous to prepare ITER scenarios in a smaller device such as FAST also from a budgetary standpoint; further, it must be taken into account the fact that this device may extend its lifetime to the DEMO construction phase and, therefore, that it can be used to test technological issues and to study plasma scenarios in preparation for DEMO as well. The FAST construction time is estimated in 6 years, following the design phase and the placement of the contracts for long lead items. Its realization will involve an average project team of 120 py/y.

### References.

- [1] ROMANELLI, F., et al., "FT3 - An Experiment to Study Burning Plasma Physics Issues in Deuterium Plasmas", *Fus. Sc. Technol.* **45** (2004) 483.
- [2] FAST-TEAM, Technical Report, ENEA/FPN-FAST-RT-07/001
- [3] CALABRO' G., et al.. "The FAST plasma scenarios and equilibrium configurations", 22<sup>nd</sup> IAEA FEC, 13-18 October 2008, Geneva, Switzerland.
- [4] MADDALUNO G. et al., "Edge Plasma Physics Issues for the Fusion Advanced Studies Torus (FAST) in Reactor Relevant Conditions", 22<sup>nd</sup> IAEA FEC, 13-18 October 2008, Geneva, Switzerland.
- [5] CARDINALI A., et al., "Minority Ions Acceleration by ICRH: a tool for investigating Burning Plasma Physics", 22<sup>nd</sup> IAEA FEC, 13-18 October 2008, Geneva, Switzerland.
- [6] CUCCHIARO A., et al., "Load Assembly Design of the FAST Machine", 22<sup>nd</sup> IAEA FEC, 13-18 October 2008, Geneva, Switzerland.
- [7] CALABRO' G., et al. "Toroidal field ripple reduction studies for ITER and FAST", 25<sup>th</sup> SOFT, September 15 - 19, 2008, Rostock, Germany.
- [8] ZONCA, F. et al., "Physics of burning plasmas in toroidal confinement devices", *Plasma Phys. Control. Fusion* **48** (2006) B15
- [9] CHEN, L., and ZONCA F., "Theory of Alfvén waves and energetic particle physics in burning plasmas", *Nucl. Fusion* **47** (2007) S727
- [10] MIRIZZI F., et al., "The three RF additional heating systems for FAST; 25<sup>th</sup> SOFT, September 15 - 19, 2008, Rostock, Germany
- [11] PERICOLI RIDOLFINI V., et al., "Edge properties with the liquid lithium limiter in FTU-experiment and transport modelling" *Plasma Phys. Control. Fusion* **49** (2007) S123–S135
- [12] ENEA, "Ignitor Project Feasibility Study" Status Report Nov. 1988 (ENEA Contract n° 24137) – Italy